

## VRG... Series

---

### VRG... Butterfly Valves

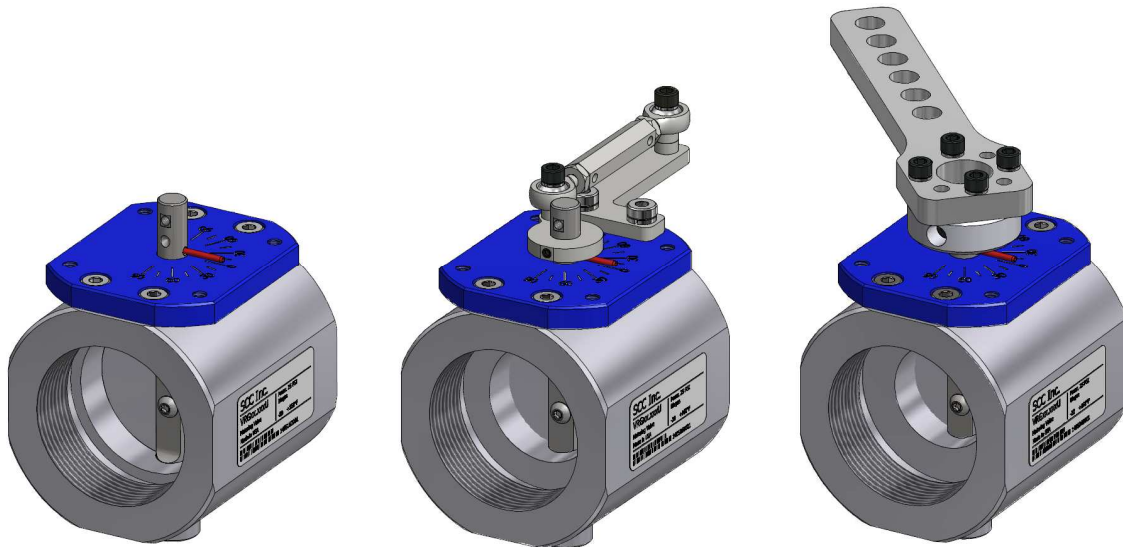

---

### Description

VRG... series threaded butterfly valves control the flow of biogas.

---

### Features

- ½" to 4" NPT threaded versions available
  - ½" to 3" Rp threaded versions available
  - Full, medium, or reduced port versions available to optimize pressure drop and flow control
  - Shaft supported by precision bearings for repeatable performance
  - Low leakage rate at full closed position without a beveled disk
  - Low pressure drop at the full open position
  - Corrosion-resistant for outdoor applications
  - Clear position indication on a 2" laser-etched, anodized dial
  - 90° clockwise or counterclockwise rotation
  - Manual kits available for fixed position adjustment
  - Crank arm kit available for linkage applications
  - Valve actuator assemblies available (Document No. VA-7000)
  - Flow in either direction
-

---

## Application

VRG... series butterfly valves control the flow of biogas. Valves are positioned using a manual kit, crank arm kit, or rotary actuator. VRG... series butterfly valves are not intended for use as shutoff valves. The valve body contains (2) identical female pipe threads for a gas tight seal with piping. Full, medium, and reduced port sizes are offered to optimize control.

---

## Use

VRG... series butterfly valves are designed for use with slightly aggressive and dry gases such as biogas, digester gas, and some process gases. These gases can have a concentration of no more than:

- 1% (by volume) of hydrogen sulfide (H<sub>2</sub>S)
- 1% (by volume) of ammonia (NH<sub>3</sub>)

In addition, condensation (moisture) in the valve is not permitted!

If other aggressive gas components are encountered other than the ones listed above, contact SCC to determine the suitability of a VRG... valve.

---

---

## Product Part Numbers

The part number structure includes port size, pipe size, and thread type. The example part number is a VRG... series full port, 2" NPT butterfly valve.

	<b>VRG</b>	<b>10</b>	<b>.</b>	<b>050</b>	<b>U</b>
<b>Model</b>					
<b>Port Size</b>					
10 = Full Port					
20 = Medium Port					
30 = Reduced Port					
<b>Pipe Size</b>					
<b>(mm) (inches)</b>					
015 = 1/2" → Full Port only					
020 = 3/4" → Full Port only					
025 = 1" → Full Port & Medium Port					
032 = 1-1/4" → Full Port & Medium Port					
040 = 1-1/2"					
050 = 2"					
065 = 2-1/2"					
080 = 3"					
100 = 4" → NPT only					
<b>Thread Type</b>					
U = NPT					
E = Rp					

## Product Part Numbers (continued)

NPT threaded butterfly valve part numbers, ratings, and port diameters are tabulated below.

**Table 1: NPT Threaded Butterfly Valve Part Numbers**

Port Type	Part Number	Max Operating Pressure	Max Surge Pressure	Temperature Range	Pipe Size inch	Port Diameter inch [mm]
Full	VRG10.015U	25 psig [170 kPa]	75 psig [510 kPa]	-20 to 160°F [-29 to 70°C]	1/2	0.61 [15.5]
	VRG10.020U				3/4	0.87 [22.1]
	VRG10.025U				1	1.10 [27.9]
	VRG10.032U				1-1/4	1.46 [37.1]
	VRG10.040U				1-1/2	1.65 [41.9]
	VRG10.050U				2	2.13 [54.1]
	VRG10.065U				2-1/2	2.64 [67.1]
	VRG10.080U				3	3.23 [82.0]
	VRG10.100U	15 psig [100 kPa]	4	4.17 [105.9]		
Medium	VRG20.025U	25 psig [170 kPa]	75 psig [510 kPa]	-20 to 160°F [-29 to 70°C]	1	0.87 [22.1]
	VRG20.032U				1-1/4	1.10 [27.9]
	VRG20.040U				1-1/2	1.46 [37.1]
	VRG20.050U				2	1.65 [41.9]
	VRG20.065U				2-1/2	2.13 [54.1]
	VRG20.080U				3	2.64 [67.1]
	VRG20.100U				4	3.23 [82.0]
Reduced	VRG30.040U	25 psig [170 kPa]	75 psig [510 kPa]	-20 to 160°F [-29 to 70°C]	1-1/2	1.10 [27.9]
	VRG30.050U				2	1.46 [37.1]
	VRG30.065U				2-1/2	1.65 [41.9]
	VRG30.080U				3	2.13 [54.1]
	VRG30.100U				4	2.64 [67.1]

## Product Part Numbers (continued)

Rp threaded butterfly valve part numbers, ratings, and port diameters are tabulated below.

**Table 2: Rp Threaded Butterfly Valve Part Numbers**

Port Type	Part Number	Max Operating Pressure	Max Surge Pressure	Temperature Range	Pipe Size inch	Port Diameter inch [mm]
Full	VRG10.015E	25 psig [170 kPa]	75 psig [510 kPa]	-20 to 160°F [-29 to 70°C]	1/2	0.61 [15.5]
	VRG10.020E				3/4	0.87 [22.1]
	VRG10.025E				1	1.10 [27.9]
	VRG10.032E				1-1/4	1.46 [37.1]
	VRG10.040E				1-1/2	1.65 [41.9]
	VRG10.050E				2	2.13 [54.1]
	VRG10.065E				2-1/2	2.64 [67.1]
	VRG10.080E				3	3.23 [82.0]
Medium	VRG20.025E	25 psig [170 kPa]	75 psig [510 kPa]	-20 to 160°F [-29 to 70°C]	1	0.87 [22.1]
	VRG20.032E				1-1/4	1.10 [27.9]
	VRG20.040E				1-1/2	1.46 [37.1]
	VRG20.050E				2	1.65 [41.9]
	VRG20.065E				2-1/2	2.13 [54.1]
	VRG20.080E				3	2.64 [67.1]
Reduced	VRG30.040E	25 psig [170 kPa]	75 psig [510 kPa]	-20 to 160°F [-29 to 70°C]	1-1/2	1.10 [27.9]
	VRG30.050E				2	1.46 [37.1]
	VRG30.065E				2-1/2	1.65 [41.9]
	VRG30.080E				3	2.13 [54.1]

---

## Accessories

### VA... Valve Actuator Assemblies



Valve actuator assemblies ensure proper shaft alignment and engagement. A VRG... valve, SQM... actuator, coupling, and bracket are built, tested, and shipped as a VA... assembly. Valve actuator assemblies are available with the following Siemens actuators:

- SQM45...
- SQM33...
- SQM40/41...
- SQM5...

For additional information see Document No. VA-7000.

### AGA92.1



A manual kit with fine adjustment can be added to any VRG... butterfly valve for use as a flow restrictor. The kit allows for precision position adjustment by turning a hex coupling; (14) revolutions make a 90° stroke. Locking nuts maintain the precise position at all rated flow pressures.

### AGA92.2

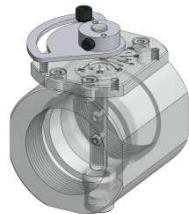

A manual kit with coarse adjustment can be added to any VRG... butterfly valve.

### AGA92.3



A crank arm kit with (6) 3/8" clearance holes can be added to any VRG... series butterfly valve for use with a linkage system.

## Materials

Below is a typical valve cross-section that identifies the materials used in the VRG product line.

**Table 3: VRG Parts**

Item	Description	Material
A	Valve body	Aluminum-6061
B	Seal	HNBR
C	Shaft	Stainless Steel (300-series)
D	Dial	Aluminum-6061
E	Shim	Teflon
F	Bearing (ball)	Steel
G	Shim	Stainless Steel
H	Fastener	Steel / Stainless Steel
I	Disk	Stainless Steel (300-series)
J	Bearing (sleeve)	Acetal
K	Bearing (thrust)	Acetal
L	Spring	Stainless Steel (17-4 PH)
M	Plug	Aluminum-6061

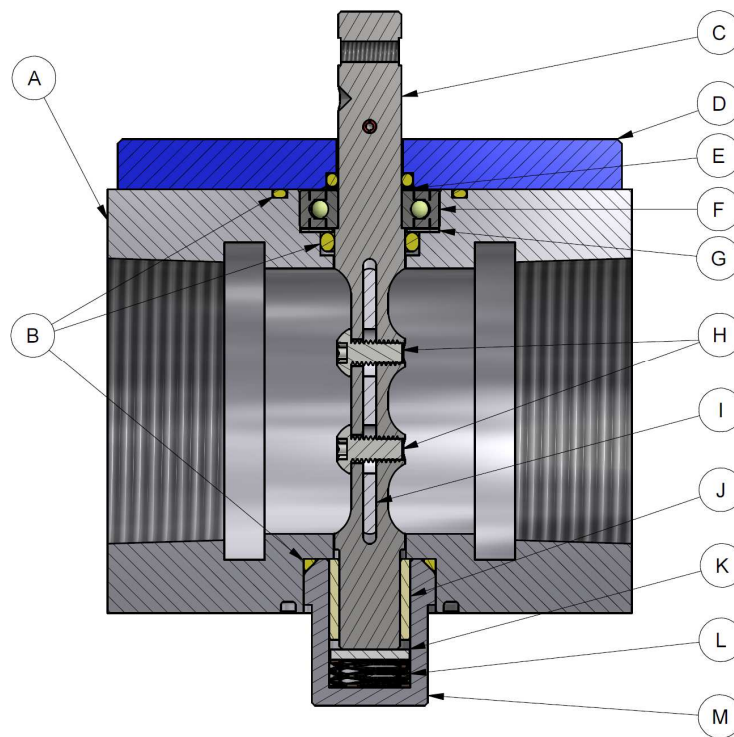

**Figure 1: Cross-section of a VRG10.040U**



## Flow Data

Biogas flow (SCFH) through the valve body and the corresponding boiler horsepower (BHP) are tabulated at common differential pressures. Valve data is sorted by ascending Cv value for ease of selection. Cv values can be utilized to calculate flow at any operating condition (see page 13).

Flow is calculated with an inlet pressure of 15" wc, a media temperature of 60°F, and a specific gravity of 0.86. Horsepower assumes a boiler efficiency of 85% and a biogas heating value of 550 BTU/SCF.

**Table 4: Flow Rates of Biogas at Full Open Position (0.5-3" wc Differential Pressure)**

Part Number	Thread Size	Port**	Cv	0.5" wc		1" wc		1.5" wc		2" wc		3" wc	
				SCFH	BHP*	SCFH	BHP*	SCFH	BHP*	SCFH	BHP*	SCFH	BHP*
VRG10.015x	1/2	FULL	5	175	2	247	3	303	4	350	5	428	6
VRG20.025x	1	MED.	19	655	9	925	13	1,133	16	1,308	18	1,601	22
VRG10.020x	3/4	FULL	20	658	9	931	13	1,139	16	1,315	18	1,610	22
VRG30.040x	1-1/2	RED.	30	1,014	14	1,434	20	1,756	25	2,027	28	2,481	35
VRG10.025x	1	FULL	31	1,060	15	1,499	21	1,835	26	2,118	30	2,593	36
VRG20.032x	1-1/4	MED.	41	1,388	19	1,962	27	2,403	34	2,773	39	3,395	47
VRG30.050x	2	RED.	62	2,092	29	2,958	41	3,622	51	4,181	58	5,118	71
VRG10.032x	1-1/4	FULL	75	2,523	35	3,567	50	4,367	61	5,041	70	6,170	86
VRG30.065x	2-1/2	RED.	76	2,566	36	3,628	51	4,441	62	5,127	72	6,276	88
VRG20.040x	1-1/2	MED.	81	2,743	38	3,878	54	4,749	66	5,482	77	6,709	94
VRG20.050x	2	MED.	97	3,275	46	4,630	65	5,669	79	6,544	91	8,010	112
VRG10.040x	1-1/2	FULL	100	3,375	47	4,771	67	5,842	82	6,744	94	8,254	115
VRG30.080x	3	RED.	147	4,966	69	7,021	98	8,597	120	9,924	139	12,147	170
VRG20.065x	2-1/2	MED.	170	5,737	80	8,110	113	9,930	139	11,463	160	14,031	196
VRG10.050x	2	FULL	180	6,078	85	8,593	120	10,521	147	12,146	170	14,866	208
VRG30.100U	4	RED.	204	6,885	96	9,735	136	11,919	166	13,759	192	16,841	235
VRG10.065x	2-1/2	FULL	255	8,583	120	12,135	169	14,858	208	17,151	240	20,994	293
VRG20.080x	3	MED.	275	9,279	130	13,119	183	16,062	224	18,541	259	22,695	317
VRG20.100U	4	MED.	431	14,525	203	20,535	287	25,142	351	29,023	405	35,525	496
VRG10.080x	3	FULL	438	14,774	206	20,888	292	25,574	357	29,522	412	36,135	505
VRG10.100U	4	FULL	828	27,928	390	39,484	551	48,344	675	55,806	779	68,308	954

\* BHP calculated at 85% boiler efficiency

\*\* MED. = Medium RED. = Reduced

## Flow Data (continued)

Flow is calculated with an inlet pressure of 1 psig, a media temperature of 60°F, and a specific gravity of 0.86. Horsepower assumes a boiler efficiency of 85% and a biogas heating value of 550 BTU/SCF.

**Table 5: Flow Rates of Biogas at Full Open Position (4-12" wc Differential Pressure)**

Part Number	Thread Size	Port**	Cv	4" wc		6" wc		8" wc		10" wc		12" wc	
				SCFH	BHP*	SCFH	BHP*	SCFH	BHP*	SCFH	BHP*	SCFH	BHP*
VRG10.015x	1/2	FULL	5	502	7	614	9	708	10	790	11	865	12
VRG20.025x	1	MED.	19	1,876	26	2,295	32	2,647	37	2,956	41	3,234	45
VRG10.020x	3/4	FULL	20	1,886	26	2,308	32	2,662	37	2,972	42	3,252	45
VRG30.040x	1-1/2	RED.	30	2,907	41	3,556	50	4,102	57	4,580	64	5,012	70
VRG10.025x	1	FULL	31	3,038	42	3,717	52	4,287	60	4,788	67	5,238	73
VRG20.032x	1-1/4	MED.	41	3,978	56	4,866	68	5,612	78	6,268	88	6,858	96
VRG30.050x	2	RED.	62	5,997	84	7,336	102	8,461	118	9,449	132	10,338	144
VRG10.032x	1-1/4	FULL	75	7,230	101	8,844	124	10,201	142	11,392	159	12,464	174
VRG30.065x	2-1/2	RED.	76	7,354	103	8,996	126	10,375	145	11,587	162	12,678	177
VRG20.040x	1-1/2	MED.	81	7,862	110	9,618	134	11,093	155	12,388	173	13,554	189
VRG20.050x	2	MED.	97	9,386	131	11,482	160	13,243	185	14,789	207	16,182	226
VRG10.040x	1-1/2	FULL	100	9,672	135	11,832	165	13,647	191	15,240	213	16,675	233
VRG30.080x	3	RED.	147	14,234	199	17,412	243	20,083	280	22,427	313	24,539	343
VRG20.065x	2-1/2	MED.	170	16,441	230	20,113	281	23,197	324	25,905	362	28,345	396
VRG10.050x	2	FULL	180	17,420	243	21,310	298	24,578	343	27,448	383	30,032	419
VRG30.100U	4	RED.	204	19,733	276	24,141	337	27,843	389	31,093	434	34,021	475
VRG10.065x	2-1/2	FULL	255	24,599	344	30,093	420	34,708	485	38,760	541	42,410	592
VRG20.080x	3	MED.	275	26,593	371	32,532	454	37,521	524	41,902	585	45,847	640
VRG20.100U	4	MED.	431	41,627	581	50,923	711	58,733	820	65,589	916	71,766	1,002
VRG10.080x	3	FULL	438	42,342	591	51,798	723	59,742	834	66,716	932	72,999	1,019
VRG10.100U	4	FULL	828	80,040	1,118	97,916	1,367	112,932	1,577	126,116	1,761	137,992	1,927

\* BHP calculated at 85% boiler efficiency

\*\* MED. = Medium RED. = Reduced

## Flow Data (continued)

Flow is calculated with an atmospheric outlet pressure, a media temperature of 60°F, and a specific gravity of 0.86.

**Table 6: Leakage Rate (SCFH) of Biogas at Full Closed Position (1-16" wc Inlet Pressure)**

Part Number	Thread Size	Port	1" wc	2" wc	4" wc	8" wc	16" wc
			SCFH	SCFH	SCFH	SCFH	SCFH
VRG10.015x	1/2	FULL	2.8	4.7	7.9	13.6	22.9
VRG20.025x	1	MEDIUM	2.9	5.3	9.4	16.2	25.1
VRG10.020x	3/4	FULL	3.1	5.3	9.3	15.7	25.0
VRG30.040x	1-1/2	REDUCED	3.0	5.4	9.7	17.0	26.2
VRG10.025x	1	FULL	2.8	4.9	8.9	15.3	24.8
VRG20.032x	1-1/4	MEDIUM	3.1	5.3	9.3	15.9	25.8
VRG30.050x	2	REDUCED	3.3	6.0	10.9	18.7	28.3
VRG10.032x	1-1/4	FULL	2.8	5.4	9.6	16.9	25.9
VRG30.065x	2-1/2	REDUCED	2.9	5.4	10.1	17.6	27.2
VRG20.040x	1-1/2	MEDIUM	3.6	6.4	11.2	19.4	29.2
VRG20.050x	2	MEDIUM	3.6	7.8	14.7	23.6	35.0
VRG10.040x	1-1/2	FULL	2.4	5.9	12.2	20.9	31.5
VRG30.080x	3	REDUCED	3.6	6.2	10.9	19.2	28.5
VRG20.065x	2-1/2	MEDIUM	3.3	5.9	10.3	18.4	28.1
VRG10.050x	2	FULL	2.8	7.0	13.8	22.5	34.2
VRG30.100U	4	REDUCED	3.8	7.0	11.7	20.6	30.3
VRG10.065x	2-1/2	FULL	3.4	5.9	10.9	19.2	28.4
VRG20.080x	3	MEDIUM	3.6	6.2	10.9	19.1	28.8
VRG20.100U	4	MEDIUM	3.8	7.2	12.9	20.9	30.7
VRG10.080x	3	FULL	4.0	7.0	12.1	20.8	30.2
VRG10.100U	4	FULL	3.7	7.2	12.5	21.1	30.6

## Flow Data (continued)

**Approximate** pressure drops for a valve at a given flow rate may be determined using the chart below.

Note: When the pressure drop is more than 50% of the inlet pressure ( $P_1$ ), choked flow occurs and the chart is no longer accurate.

Flow is calculated with an inlet pressure of 1 psig, a media temperature of 60°F, and a specific gravity of 0.86.

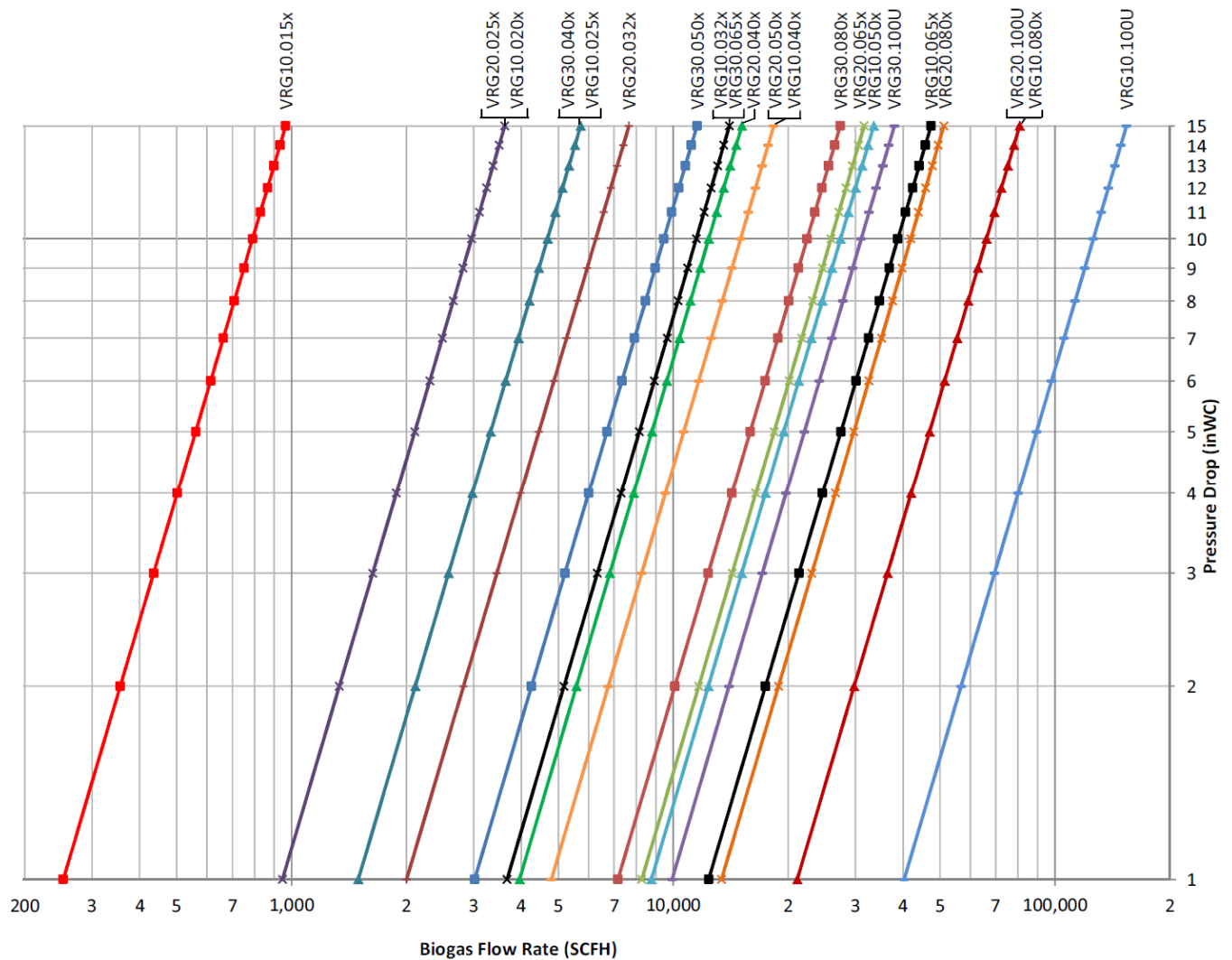

**Figure 3: Logarithmic Scale Plot of VRG Biogas Flow Capacities for Full Open Position**

## Flow Data (continued)

Flow rate (SCFH) through the valve body at the full open position can be estimated using the equation below and the  $C_v$  values from Table 4.

$$Q = 1360 \times C_v \times \left( \sqrt{\frac{P_1 + P_2}{GT_f}} \right) \times \left( \sqrt{\frac{P_1 - P_2}{2}} \right)$$

...where...

$C_v$  = Flow coefficient (see Table 4)

$G$  = Specific gravity of gas (see Table 7)

$P_1$  = Absolute inlet pressure in PSIA (PSIG + 14.7)

$P_2$  = Absolute outlet pressure in PSIA (PSIG + 14.7)

$Q$  = Flow rate in SCFH

$T_f$  = Media temperature in degrees Rankine ( $^{\circ}\text{F} + 460$ )

Boiler horsepower is calculated using the equation below.

$$\text{Boiler hp} = Q \times (\text{HHV}) \times \eta \times \frac{1 \text{ Boiler hp}}{33,475 \text{ BTU/HR}}$$

...where...

$Q$  = Flow rate (SCFH)

HHV = Higher Heating Value (BTU/SCF)

$\eta$  = Boiler efficiency (assume: 85% efficiency or 0.85)

**Table 7: Constants for Boiler Horsepower Calculations by Applicable Gases**

Type of Gas	Specific Gravity	Higher Heating Value (BTU/SCF)
Biogas	0.86	550

---

## Actuator Torque

Torque requirements for the 4" full port valve (VRG10.100U) are tabulated at various differential pressures to ensure proper actuator selection. The VRG10.100U valve requires more torque than all other models. Maximum torque occurs at approximately the 60 degree position at high flow rates. A maximum of 20 in-lbs is required to modulate any VRG... valve.

**Table 8: Maximum Torque Values at Various Pressure Differentials**

Differential Pressure		Torque	
psi	kPa	in-lbs	N-m
6	41	10	1.13
10	69	15	1.69
15	100	20	2.26

## Dimensions

Dimensions in inches; millimeters in brackets

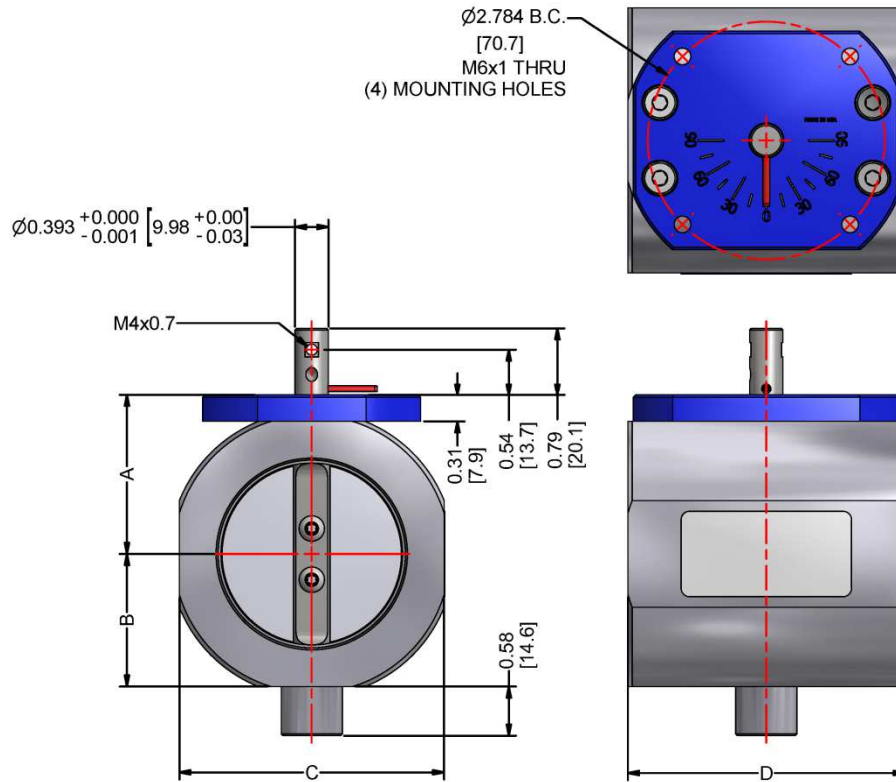

Figure 4: Dimensions of the VRG... Valve Shown on a VRG10.050U

Table 9: VRG... Valve Dimensions

Part Number	A	B	C	D	E*
VRGxx.015x	1.35 [34]	1.04 [26]	2.08 [53]	3.25 [83]	2.52 [64]
VRGxx.020x	1.35 [34]	1.04 [26]	2.08 [53]	3.25 [83]	2.52 [64]
VRGxx.025x	1.35 [34]	1.04 [26]	2.08 [53]	3.25 [83]	2.52 [64]
VRGxx.032x	1.53 [39]	1.22 [31]	2.44 [62]	3.25 [83]	2.70 [69]
VRGxx.040x	1.63 [41]	1.31 [33]	2.63 [67]	3.25 [83]	2.80 [71]
VRGxx.050x	1.87 [47]	1.55 [39]	3.11 [79]	3.25 [83]	3.03 [77]
VRGxx.065x	2.18 [55]	1.87 [47]	3.74 [95]	4.38 [111]	3.29 [84]
VRGxx.080x	2.44 [62]	2.13 [54]	4.26 [108]	4.38 [111]	3.58 [91]
VRGxx.100U	2.96 [75]	2.64 [67]	5.28 [134]	5.00 [127]	4.09 [104]

\* Dimension E shown on page 17

## Dimensions (continued)

Dimensions in inches; millimeters in brackets

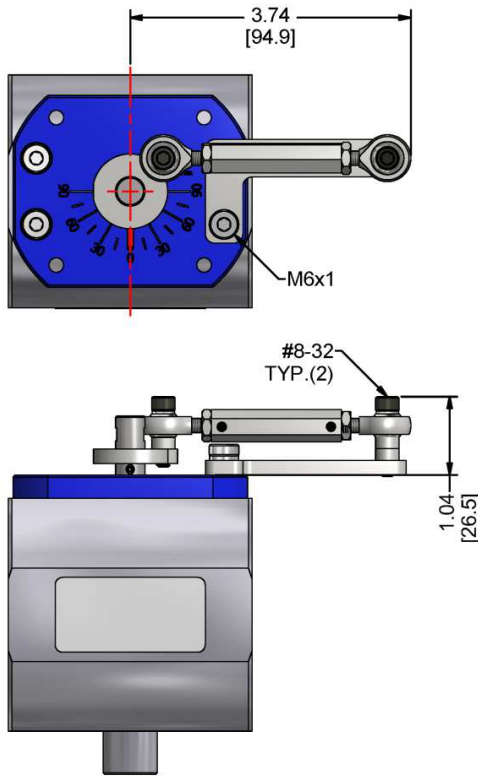

**Figure 5: Dimensions of the AGA92.1  
Manual Kit**

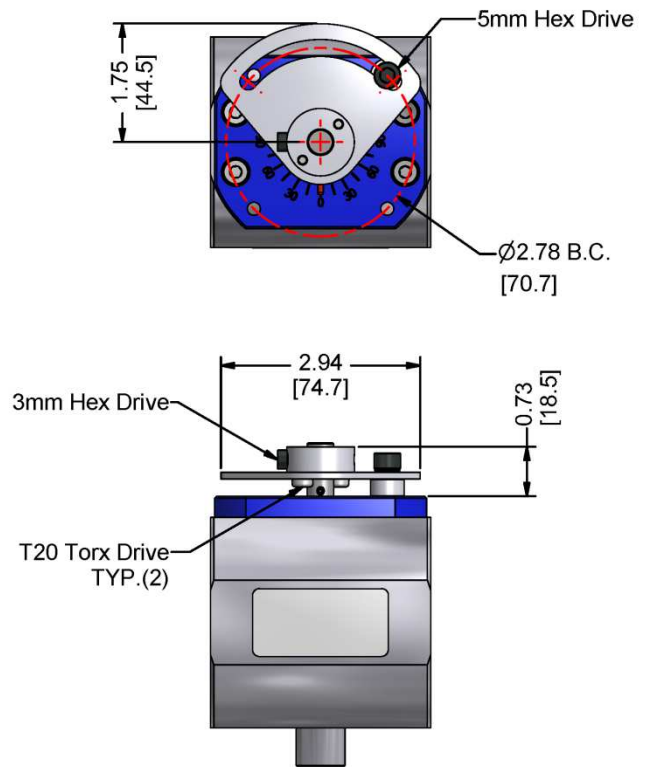

**Figure 6: Dimensions of the AGA92.2  
Manual Kit**

## Dimensions (continued)

Dimensions in inches; millimeters in brackets

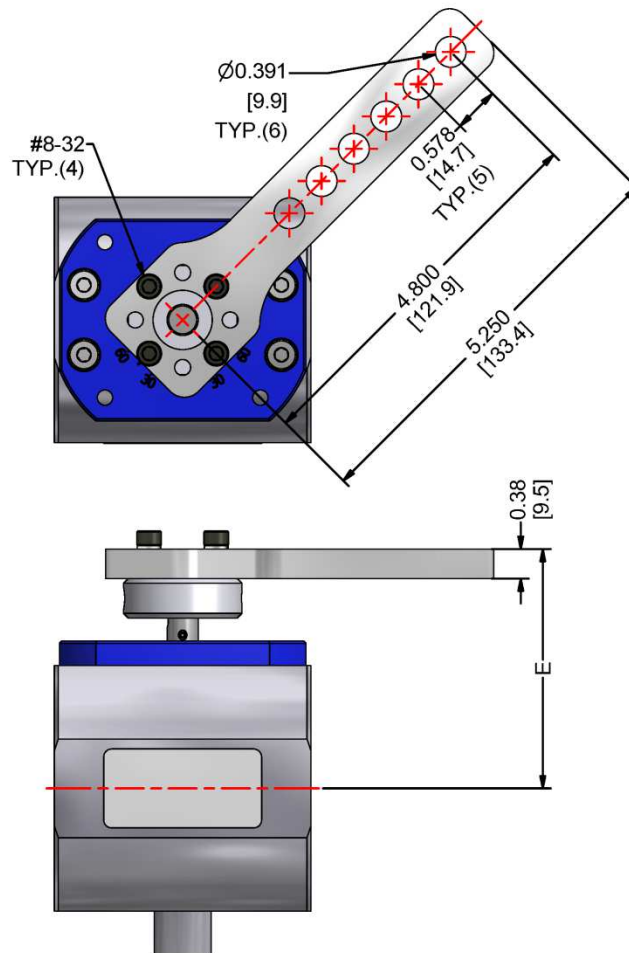

**Figure 7: Dimensions of the AGA92.3 Linkage Kit**

Information in this publication is based on current specifications. The company reserves the right to make changes in specifications and models as design improvements are introduced. Product or company names mentioned herein may be the trademarks of their respective owners. © 2009 SCC Inc.