

VKF... Series

VKF41... Butterfly Valves for Flow Control of Gases

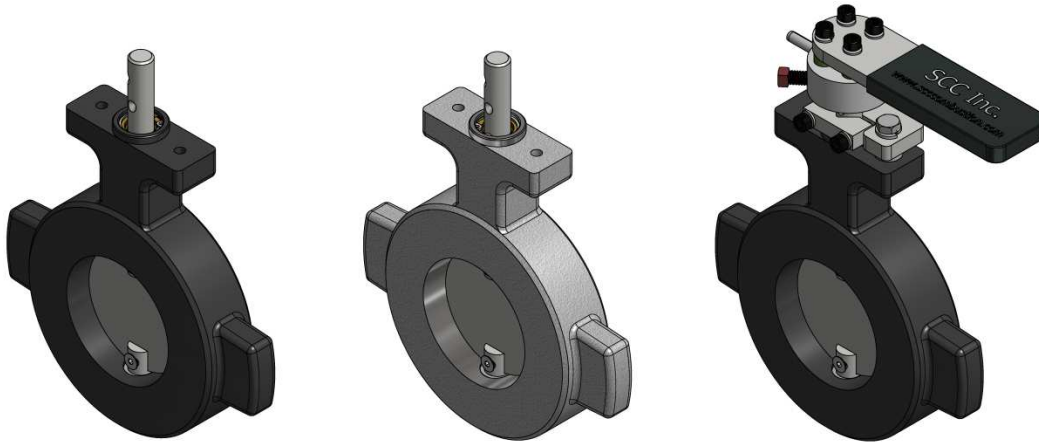

Description

VKF... series butterfly valves are designed to control the flow of many common gases.

Features

- Standard VKF...C versions for air, natural gas, or propane
- High-temperature VKF...H versions for FGR or hot air up to 550°F
- Biogas VKF...B versions for corrosive gases such as biogas
- DN40 (1½") through DN200 (8")
- Accommodates flow in either direction
- Locking manual handle with valve position indicator

Application

VKF... series butterfly valves are used to throttle gases such as air, natural gas, or propane. These valves are wafer type, and mount between ANSI or DIN pipe flanges. Additional versions of the VKF... series butterfly valves are available for high-temperature or corrosive gas applications.

Product Part Numbers

Table 1: VKF41... Butterfly Valve Part Numbers

Size	Product Part Number		
	Standard	High-temperature	Biogas
1.5"	VKF41.40C	VKF41.40H	VKF41.40B
2"	VKF41.50C	VKF41.50H	VKF41.50B
2.5"	VKF41.65C	VKF41.65H	VKF41.65B
3"	VKF41.80C	VKF41.80H	VKF41.80B
4"	VKF41.100C	VKF41.100H	VKF41.100B
6"	VKF41.150C	VKF41.150H	VKF41.150B
8"	VKF41.200C	VKF41.200H	VKF41.200B

*Contact SCC Inc. if a valve larger than 8" is necessary.

Accessories

VKF41-MH



A manual handle kit can be added to any VKF41... butterfly valve for use as a manual flow restrictor. The kit includes position indicator and a handle with clamping pieces to lock the valve in any position. Add "-MH" to the end of any VKF41... valve part number to have the valve shipped with the manual handle kit attached.

VKF41-LH



A linkage kit for any VKF41... butterfly valve including position indicator. Holes in the handle allow users to connect a linkage (by others) to control valve position. Add "-LH" to the end of any VKF41... valve part number to have the valve assembled with the linkage handle.

VA... Valve Actuator Assemblies



Valve-actuator assemblies ensure proper shaft alignment and engagement. Assemblies include the valve, actuator, coupling, bracket, and position indicator which are configured, tested, and shipped as an assembly. Contact SCC Inc. for more information.

VKF41-RPI



Optional position indicator for any VKF41... butterfly valve. Once installed, two pins line up parallel to the valve disc to show valve position. See "Installation" for more information.

Accessories (continued)

Cxx... Couplings



Couplings are available for mounting Siemens SQM... actuators to any VKF41... butterfly valve. Choose the proper coupling depending on the SQM... actuator shaft and the VKF41... valve type being assembled.

- CCM10KCB-M12RSA:** 10mm keyed to standard VKF41...C valves
- CDM10KCB-M12RSB:** 10mm keyed to high-temperature VKF41...H valves
- CCM10KCB-M12RSB:** 10mm keyed to biogas VKF41...B valves
- CCM10DCA-M12RSA:** 10mm "D" to standard VKF41...C valves
- CDM10DCA-M12RSB:** 10mm "D" to high-temperature VKF41...H valves
- CCM10DCA-M12RSB:** 10mm "D" to biogas VKF41...B valves
- CCE6SCA-M12RSA:** 3/8" square (140 in-lb or fewer) to standard VKF41...C valves
- CDE6SCA-M12RSB:** 3/8" square (140 in-lb or fewer) to high-temperature VKF41...H valves
- CCE6SCA-M12RSB:** 3/8" square (140 in-lb or fewer) to biogas VKF41...B valves
- CFE6SCA-M12RSA:** 3/8" square (over 140 in-lb) to standard VKF41...C valves
- CHE6SCA-M12RSB:** 3/8" square (over 140 in-lb) to high-temperature VKF41...H valves
- CFE6SCA-M12RSB:** 3/8" square (over 140 in-lb) to biogas VKF41...B valves
- CFM14KCB-M12RSA:** 14mm keyed to standard VKF41...C valves
- CHM14KCB-M12RSB:** 14mm keyed to high-temperature VKF41...H valves
- CFM14KCB-M12RSB:** 14mm keyed to biogas VKF41...B valves

BR-AS... Bracket Assemblies

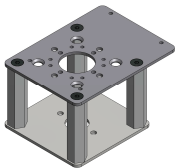

Bracket assemblies are available for mounting Siemens SQM... actuators to any VKF41... butterfly valve. BR-AS... bracket assemblies are to be used with Cxx... couplings. Choose the proper bracket assembly depending on the SQM... actuator and the VKF41... valve type being assembled.

- BR-AS21-104-4-00:** SQM33/40/41/45/5x to standard VKF41...C or biogas VKF41...B valves using a CC... style coupling
- BR-AS21-144-4-00:** SQM48/5x to standard VKF41...C or biogas VKF41...B valves using a CF... style coupling
- BR-AS21-94-3-VKF-HT:** SQM33/40/41/45/5x to standard VKF41...C or biogas VKF41...B valves using a CD... style coupling
- BR-AS21-134-3-VKF-HT:** SQM48/5x to high-temperature VKF41...H valves using a CH... style coupling

VKF41...C Butterfly Valves

VKF41...C standard butterfly valves control ambient temperature inert gases such as air, natural gas, or propane.

Specifications

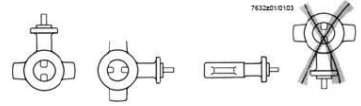
Physical characteristics	Materials	
	-Valve body	Cast iron
	-Shaft and disk	Stainless steel
	-Shaft seal	Buna-N O-rings
	-Bearings	Bronze
	-Centering spacers	Plastic
	Weight	See Table 7 on page 9
	Angular rotation	85° (beveled disc)
Operating environment	Type of gases	Air, natural gas, propane
	Operating pressure	-5 to 20 psig [-35 to 140 kPa]
	Flowing temperature	0 to 140°F [-18 to 60°C]
	Mounting positions	
	Humidity	< 95% relative humidity

Leakage rate

Table 2: VKF41...C Butterfly Valve Leakage Rates for Air* in SCFH**

Valve Size	Differential Pressure Across Valve				
	1" w.c.	2" w.c.	4" w.c.	8" w.c.	16" w.c.
1.5"	2.3	3.3	5.0	8.0	13.2
2"	2.4	4.1	7.7	13.4	21.2
2.5"	4.3	6.6	10.2	15.4	25.1
3"	6.4	10.2	18.0	30.4	54.3
4"	8.3	13.5	21.6	35.5	58.3
6"	9.7	15.2	26.6	54.3	82.4
8"	10.7	17.2	31.0	64.5	123.7

*For different gases, multiply leakage rate by correction factors from Table 6 on page 7

**Accuracy of leakage rates is ±5%

VKF41...H High-Temperature Butterfly Valves

VKF41...H high-temperature butterfly valves are typically used for FGR or hot air up to 550°F.

Specifications

Physical characteristics	Materials	
	-Valve body	Cast iron
	-Shaft and disk	Stainless steel
	-Shaft seal	PTFE
	-Bearings	PTFE
	-Centering spacers	Aluminum
	Weight	See Table 7 on page 9
	Angular rotation	360° (swing-through)

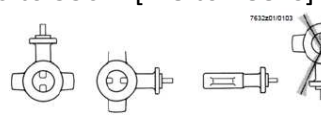
Operating environment	Type of gases	Air, FGR
	Operating pressure	-10 in w.c. to 5 psig [-2.5 to 35 kPa]
	Flowing temperature	0 to 550°F [-18 to 288°C]
	Mounting positions	
	Humidity	< 95% relative humidity

Leakage rate

Table 3: VKF41...H Butterfly Valve Leakage Rates for Air* in SCFH**

Valve Size	Differential Pressure Across Valve				
	1" w.c.	2" w.c.	4" w.c.	8" w.c.	16" w.c.
1.5"	168	242	330	451	607
2"	200	279	434	633	913
2.5"	329	482	661	922	1320
3"	345	493	706	1052	1513
4"	462	664	975	1423	2007
6"	711	974	1420	2138	3027
8"	950	1430	2053	2880	4274

*For different gases, multiply leakage rate by correction factors from Table 6 on page 7

**Accuracy of leakage rates is $\pm 5\%$

VKF41...B Biogas Butterfly Valves

VKF41...B biogas butterfly valves are typically used with corrosive gases such as digester gas. These valve bodies are electro-less nickel plated to prevent corrosion and wear caused by aggressive components of biogas such as hydrogen sulfide and ammonia.

Specifications

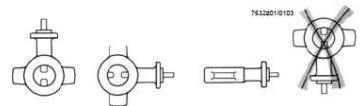
Physical characteristics	Materials	
	-Valve body	Nickel-plated cast iron
	-Shaft and disk	Stainless steel
	-Shaft seal	Buna-N O-rings
	-Bearings	PTFE
	-Centering spacers	Plastic
	Weight	See Table 7 on page 9
	Angular rotation	360° (swing-through)
Operating environment	Type of gases	Air, natural gas, propane, digester gas
	Operating pressure	-5 to 20 psig [-35 to 140 kPa]
	Flowing temperature	0 to 140°F [-18 to 60°C]
	Mounting positions	
	Humidity	< 95% relative humidity

Leakage rate

Table 4: VKF41...B Butterfly Valve Leakage Rates for Air* in SCFH**

Valve Size	Differential Pressure Across Valve				
	1" w.c.	2" w.c.	4" w.c.	8" w.c.	16" w.c.
1.5"	168	242	330	451	607
2"	200	279	434	633	913
2.5"	329	482	661	922	1320
3"	345	493	706	1052	1513
4"	462	664	975	1423	2007
6"	711	974	1420	2138	3027
8"	950	1430	2053	2880	4274

*For different gases, multiply leakage rate by correction factors from Table 6 on page 7

**Accuracy of leakage rates is ±5%

Installation

- Do not interfere with or modify the butterfly valves.
- All activities (mounting, installation, service work, etc.) must be performed by qualified staff.
- Fall or shock can adversely affect the safety functions of these valves. Such valves must not be put into operation, even if they do not exhibit any damage.
- No special tools are required.
- Use flange gaskets that are suited for the type of gas the valve will control.
- Ensure that the installation complies with relevant local and national codes.
- VKF41... butterfly valves do not require maintenance.
- For VKF...C versions, disk turns clockwise to increase flow and counterclockwise to decrease flow as viewed from shaft end. For VKF...H and VKF...B versions, disk may turn either direction to increase flow.
- VKF... valves come with four spacers to center the valve between flanges.
- To install the optional position indicator VKF41-RPI on any VKF... valve, follow the three steps below:

1. Slide position indicator over the valve shaft.



2. Line up set screw with the smaller notch in the valve shaft.

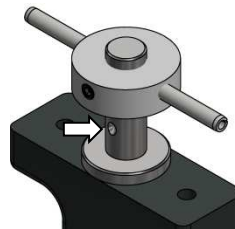

3. Tighten set screw using a 2.5mm hex key.

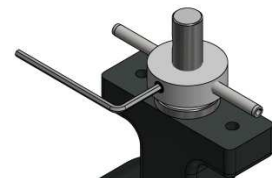

Flow Data

Flows through the valve body can be estimated using the equation below. Input data for this equation can be found in Tables 5 and 6.

$$Q = 1360 \times C_v \times \left(\sqrt{\frac{P_1 + P_2}{GT_f}} \right) \times \left(\sqrt{\frac{P_1 - P_2}{2}} \right)$$

Where:

C_v = Flow coefficient (see Table 5)

G = Specific gravity of gas (see Table 6)

P_1 = Inlet pressure in PSIA (PSIG + 14.7 psi)

P_2 = Outlet pressure in PSIA (PSIG + 14.7 psi)

Q = Flow rate in SCFH

T_f = Flowing temperature in degrees Rankine ($^{\circ}\text{F} + 460^{\circ}$)

Table 5: Flow Coefficients (C_v)

Valve	C_v
VKF41.40x	58
VKF41.50x	92
VKF41.65x	231
VKF41.80x	462
VKF41.100x	879
VKF41.150x	2428
VKF41.200x	4624

Table 6: Specific Gravities (G) and Correction Factors for Applicable Gases

Type of Gas	Specific Gravity	Correction Factor
Air	1.00	1.00
Natural Gas	0.61	1.28
Propane	1.56	0.80
Digester Gas	0.86	1.08

Flow Data (continued)

Approximate pressure drops for a given valve size and flow rate may be determined using the chart below. When pressure drop is more than 50% of the inlet pressure (P_1), choked flow occurs and chart is no longer accurate.

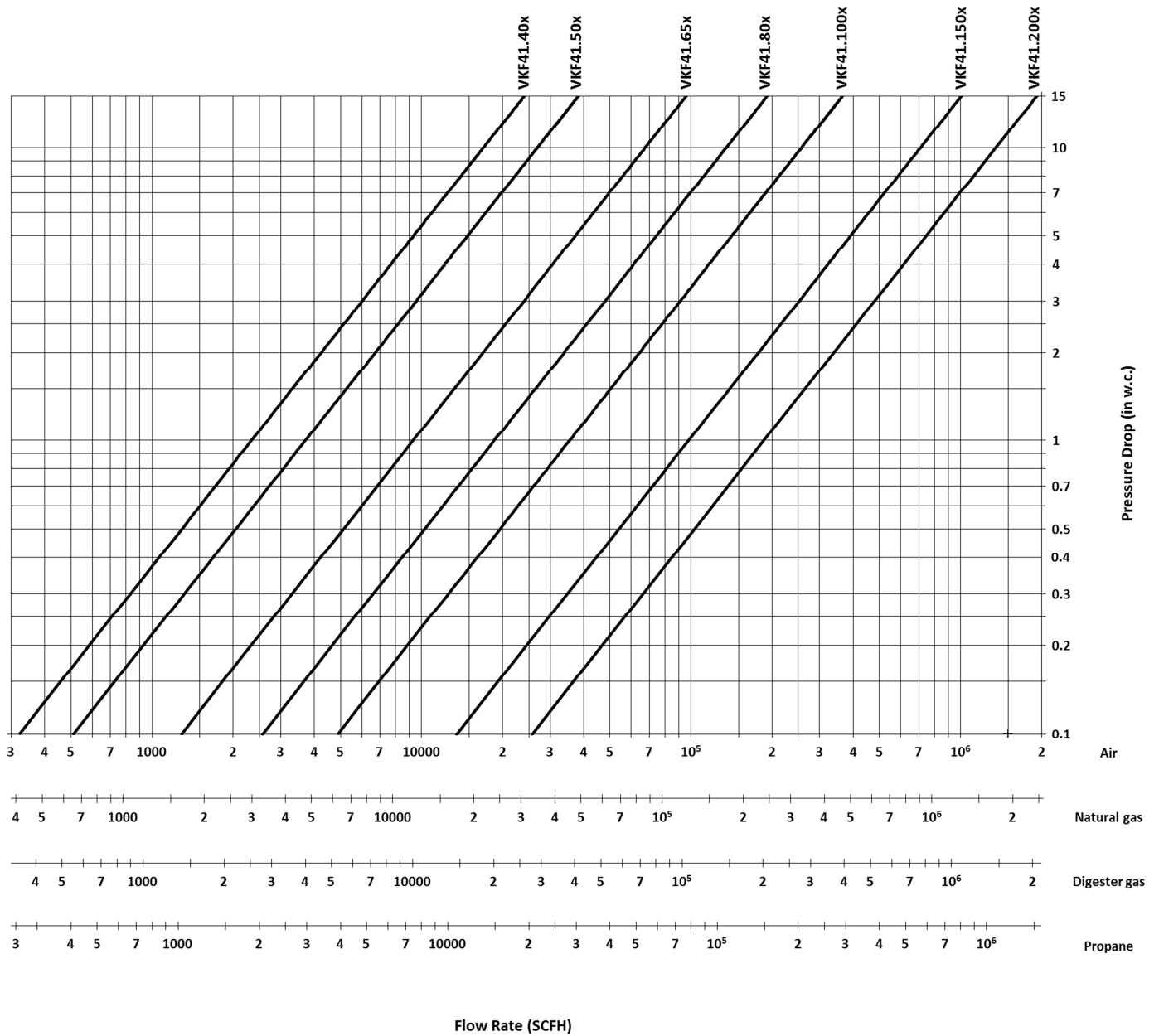

Figure 1: Capacities for Full Open VKF41... Butterfly Valves at 1 PSI Inlet

Dimensions

Dimensions in inches; millimeters in brackets

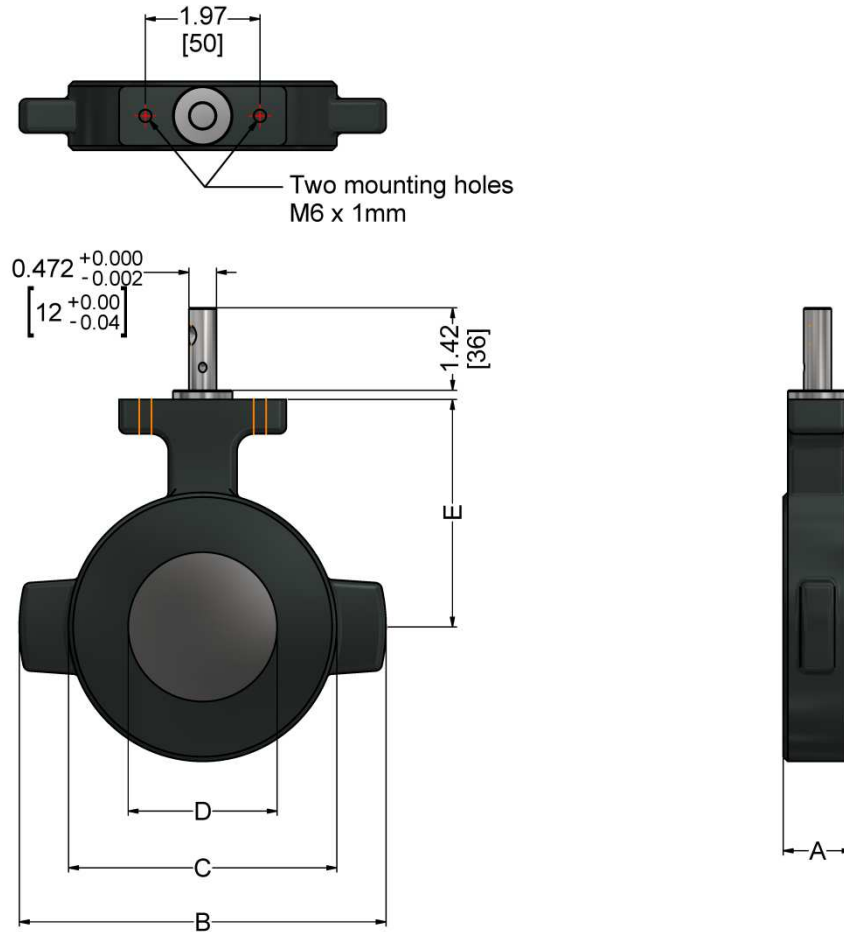

Table 7: VKF41... Valve Dimensions

Part Number	A	B	C	D	E	Weight – lb [kg]
VKF41.40x	1.18 [30]	5.12 [130]	3.43 [87]	1.57 [40]	3.43 [87]	3.79 [1.72]
VKF41.50x	1.18 [30]	5.51 [140]	3.82 [97]	1.97 [50]	3.62 [92]	4.30 [1.94]
VKF41.65x	1.18 [30]	6.30 [160]	4.61 [117]	2.56 [65]	3.92 [99.5]	5.22 [2.37]
VKF41.80x	1.18 [30]	6.89 [175]	5.24 [133]	3.15 [80]	4.21 [107]	5.80 [2.63]
VKF41.100x	1.18 [30]	7.68 [195]	6.02 [153]	3.94 [100]	4.61 [117]	6.44 [2.92]
VKF41.125x	1.57 [40]	8.86 [225]	7.20 [183]	4.92 [125]	5.41 [137.5]	11.57 [5.25]
VKF41.150x	1.57 [40]	10.04 [255]	8.19 [208]	5.91 [150]	5.91 [150]	13.87 [6.29]
VKF41.200x	1.57 [40]	12.20 [310]	10.35 [263]	7.87 [200]	6.89 [175]	18.61 [8.44]

Dimensions (continued)

Dimensions in inches; millimeters in brackets

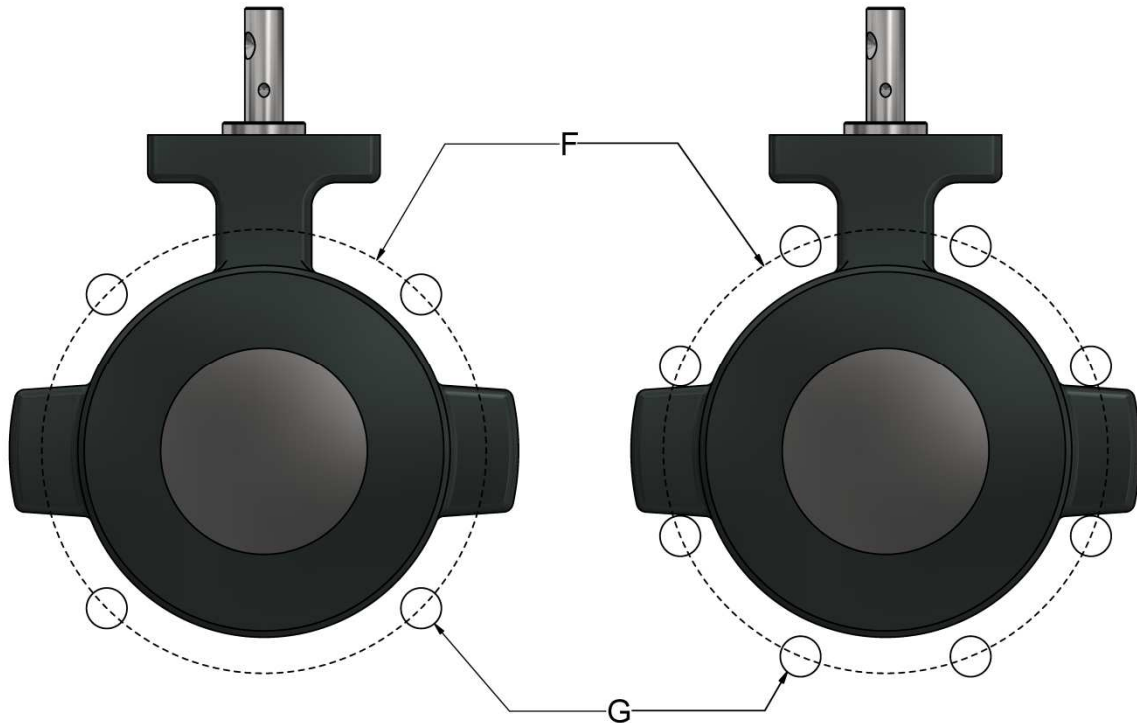

Table 8: Flange Mounting Dimensions

Valve	ANSI Flange		DIN Flange	
	Bolt Circle (F)	Mounting Screws (G)	Bolt Circle (F)	Mounting Screws (G)
VKF41.40x	See below*		4.33 [110]	M16 (4x)
VKF41.50x	4.75 [121]	5/8" (4x)	4.92 [125]	M16 (4x)
VKF41.65x	5.50 [140]	5/8" (4x)	5.71 [145]	M16 (4x)
VKF41.80x	6.00 [152]	5/8" (4x)	6.30 [160]	M16 (8x)
VKF41.100x	7.50 [191]	5/8" (8x)	7.09 [180]	M16 (8x)
VKF41.150x	9.50 [241]	3/4" (8x)	9.45 [240]	M20 (8x)
VKF41.200x	11.75 [298]	3/4" (8x)	11.61 [295]	M20 (8x)

*VKF41.40x butterfly valves must be mounted with either 2" ANSI flanges or 1½" DIN flanges.

Information in this publication is based on current specifications. The company reserves the right to make changes in specifications and models as design improvements are introduced. Product or company names mentioned herein may be the trademarks of their respective owners. © 2009 SCC Inc.