

QAx... Series

QAC... QAE... QAM... 544... Temperature Sensors

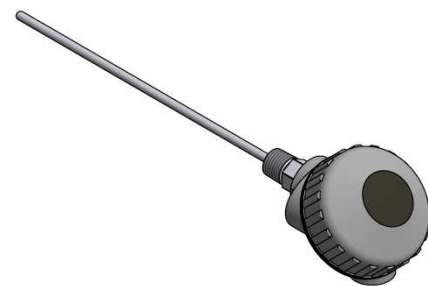
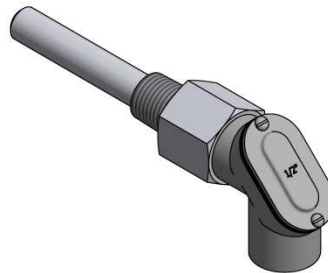

Description

QAx... and 544... temperature sensors are resistance temperature detectors (RTDs). RTDs work on the principal that the resistance of the sensing element changes as a direct function of the temperature.

Features

- Accurate and reliable indication of temperature
- Easy installation requiring no special tools
- Suitable for media -58 °F to 900 °F depending on model

Application

QAx... and 544... sensors are used to measure water, steam, air, or exhaust temperature. A variety of sensors are available in order to meet the needs of different applications. QAx... and 544... temperature sensors are capable of reliably measuring temperatures as low as -58 °F or as high as 900 °F.

Specifications

QAE2012.001

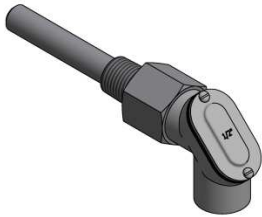

Sensing element	Platinum, 1000 Ohm, 2-wire
Characteristic	385 (see Appendix A, page 10)
Operating temperature	-4 to 374 °F [-20 to 190 °C]
Accuracy	See Appendix A, page 12
Process connection	1/2" NPT on thermowell
Thermowell	2.5" insertion, stainless steel
Weather head	Aluminum, 1/2" NPT
Primary use	Water / ambient air temperature sensor for LMV5x / RWF40 / RWF50 / RWF55

QAE2020.001

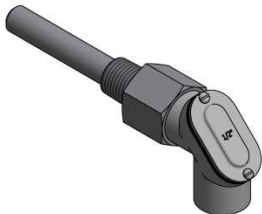

Sensing element	Platinum, 100 Ohm, 3-wire
Characteristic	385 (see Appendix A, page 10)
Operating temperature	-4 to 374 °F [-20 to 190 °C]
Accuracy	See Appendix A, page 12
Process connection	1/2" NPT on thermowell
Thermowell	2.5" insertion, stainless steel
Weather head	Aluminum, 1/2" NPT
Primary use	Water temperature sensor for LMV5x / RWF10 / RWF40 / RWF50 / RWF55

QAE2020.005

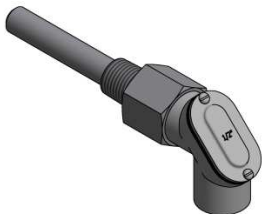

Sensing element	Nickel, 1000 Ohm, 2-wire
Characteristic	LG (see Appendix A, page 11)
Operating temperature	-13 to 266 °F [-25 to 130 °C]
Accuracy	See Appendix A, page 12
Process connection	1/2" NPT on thermowell
Thermowell	2.5" insertion, stainless steel
Weather head	Aluminum, 1/2" NPT
Primary use	Water / ambient air temperature sensor for LMV5x / RWF40 / RWF55

Specifications (continued)**QAE2020.010**

Sensing element	Nickel, 1000 Ohm, 2-wire
Characteristic	LG (see Appendix A, page 11)
Operating temperature	-13 to 266 °F [-25 to 130 °C]
Accuracy	See Appendix A, page 12
Process connection	1/2" NPT on thermowell
Thermowell	4" insertion, stainless steel
Weather head	Aluminum, 1/2" NPT
Primary use	Water / ambient air temperature sensor for LMV5x / RWF40 / RWF55

QAE2020.015

Sensing element	Nickel, 1000 Ohm, 2-wire
Characteristic	LG (see Appendix A, page 11)
Operating temperature	-13 to 266 °F [-25 to 130 °C]
Accuracy	See Appendix A, page 12
Process connection	1/2" NPT on thermowell
Thermowell	6" insertion, stainless steel
Weather head	Aluminum, 1/2" NPT
Primary use	Water / ambient air temperature sensor for LMV5x / RWF40 / RWF55

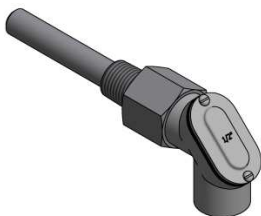
544-577-25

Sensing element	Platinum, 1000 Ohm, 2-wire
Characteristic	385 (see Appendix A, page 10)
Operating temperature	-40 to 240 °F [-40 to 116 °C]
Accuracy	See Appendix A, page 12
Process connection	1/2" NPT on thermowell
Thermowell	2.5" insertion, stainless steel
Weather head	Aluminum, 1/2" NPT
Primary use	Water / ambient air temperature sensor for LMV5x / RWF40 / RWF55

544-577-40



Sensing element	Platinum, 1000 Ohm, 2-wire
Characteristic	385 (see Appendix A, page 10)
Operating temperature	-40 to 240 °F [-40 to 116 °C]
Accuracy	See Appendix A, page 12
Process connection	1/2" NPT on thermowell
Thermowell	4" insertion, stainless steel
Weather head	Aluminum, 1/2" NPT
Primary use	Water / ambient air temperature sensor for LMV5x / RWF40 / RWF55

544-577-60



Sensing element	Platinum, 1000 Ohm, 2-wire
Characteristic	385 (see Appendix A, page 10)
Operating temperature	-40 to 240 °F [-40 to 116 °C]
Accuracy	See Appendix A, page 12
Process connection	1/2" NPT on thermowell
Thermowell	6" insertion, stainless steel
Weather head	Aluminum, 1/2" NPT
Primary use	Water / ambient air temperature sensor for LMV5x / RWF40 / RWF55

QAE2012.903

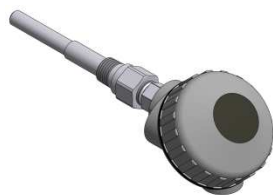

Sensing element	Platinum, 100 Ohm, 3-wire
Characteristic	385 (see Appendix A, page 10)
Operating temperature	-50 to 900 °F [-46 to 482 °C]
Accuracy	See Appendix A, page 12
Process connection	1/2" NPT on thermowell
Thermowell	4" insertion, stainless steel
Weather head	Aluminum, 3/4" NPT
Primary use	Water / steam temperature sensor for LMV5x / RWF10 / RWF40 / RWF50 / RWF55
Accessories	QAE-AC-903P: 0-900° to 4-20 mA transmitter

Specifications (continued)**QAE2012.9002**

Sensing element	Platinum, 1000 Ohm, 2-wire
Characteristic	385 (see Appendix A, page 10)
Operating temperature	-50 to 900 °F [-46 to 482 °C]
Accuracy	See Appendix A, page 12
Process connection	1/2" NPT on thermowell
Thermowell	4" insertion, stainless steel
Weather head	Aluminum, 3/4" NPT
Primary use	Water / steam temperature sensor for LMV5x / RWF10 / RWF40 / RWF50 / RWF55

QAC22

Sensing element	Nickel, 1000 Ohm, 2-wire
Characteristic	LG (see Appendix A, page 11)
Operating temperature	-58 to 158 °F [-50 to 70 °C]
Accuracy	See Appendix A, page 12
Process connection	None
Thermowell	None
Weather head	Integral, hole for M16 connection
Primary use	Ambient air temperature sensor for LMV52 / RWF40 / RWF55

QAM-P210

Sensing element	Platinum, 1000 Ohm, 2-wire
Characteristic	385 (see Appendix A, page 10)
Operating temperature	-50 to 900 °F [-46 to 482 °C]
Accuracy	See Appendix A, page 12
Probe	1/4" diameter, 10" long, stainless steel
Process connection	1/2" NPT
Thermowell	None
Weather head	Aluminum, 3/4" NPT
Primary use	Stack temperature sensor for LMV52

Wiring

QAE2012.001, QAE2020.005,
QAE2020.010, QAE2020.015,
544-577-25, 544-577-40,
544-577-60



QAE2012.9002, QAM-P210

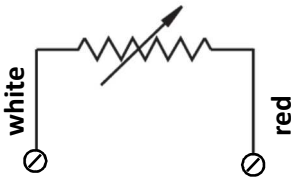

QAC22

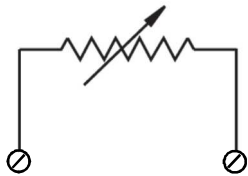

QAE2020.001

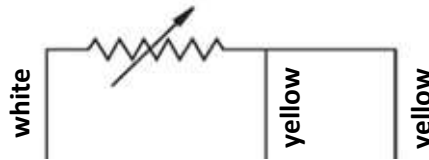

QAE2012.903

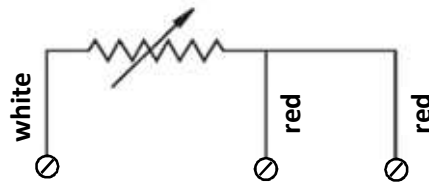

G1+	M1	I1	RWF40... water / steam
3	4	5	RWF10... water / steam
11	12	14	RWF55... water / steam
11	12	13	RWF50... water / steam
X60.1	X60.2	X60.4	LMV5x... water / steam

G1+	M1	RWF40... water / steam
B9	M9	RWF40... ambient air
11	14	RWF55... water / steam
31	32	RWF55... ambient air
11	13	RWF50... water / steam
X60.3	X60.4	LMV5x... water / steam
X86.1	X86.2	LMV52... exhaust
X87.1	X87.2	LMV52... ambient air

Note: There is no polarity when wiring a 2-wire RTD.

Dimensions

Dimensions in inches; millimeters in brackets

QAE2012.001, QAE2020.001, QAE2020.005, 544-577-25

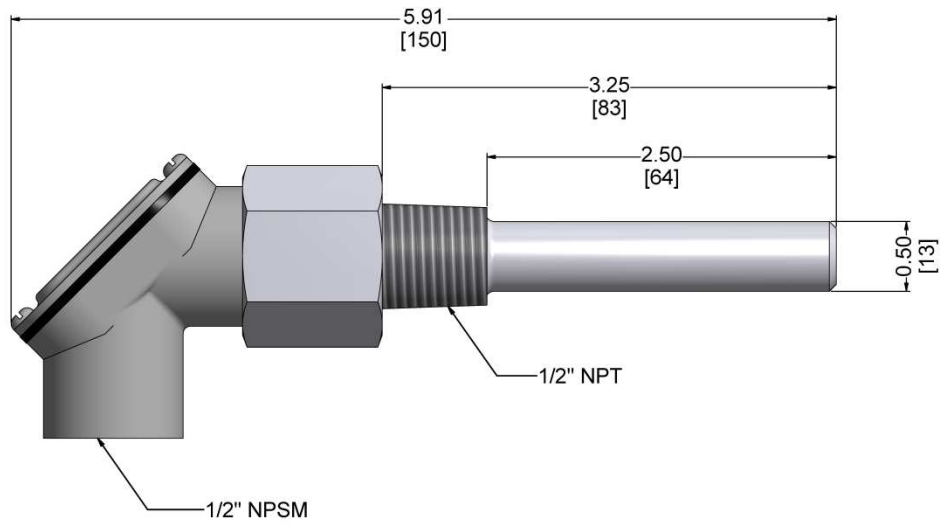

QAE2020.010, 544-577-40

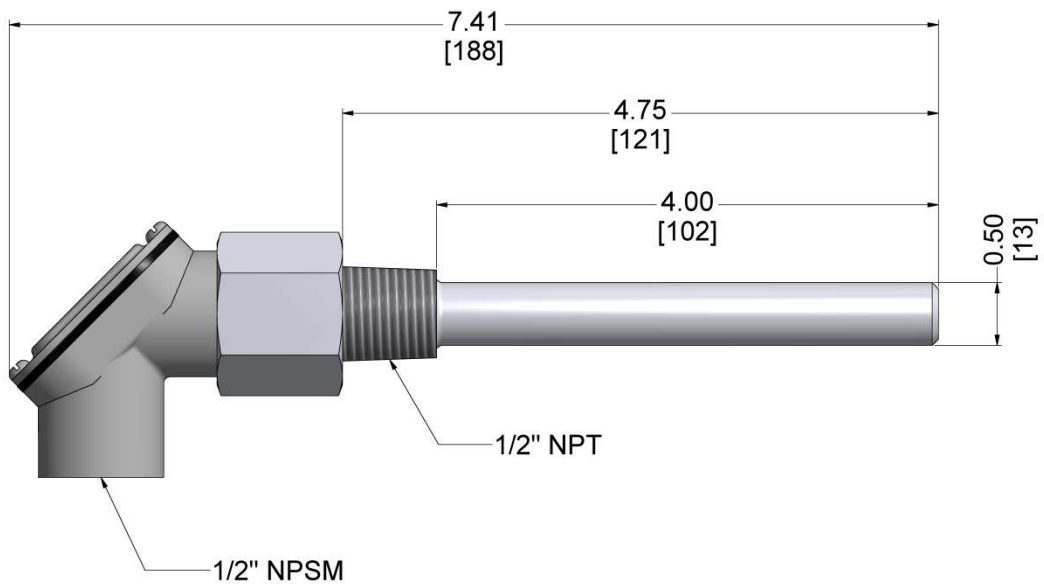

Dimensions

Dimensions in inches; millimeters in brackets

QAE2020.015, 544-577-60

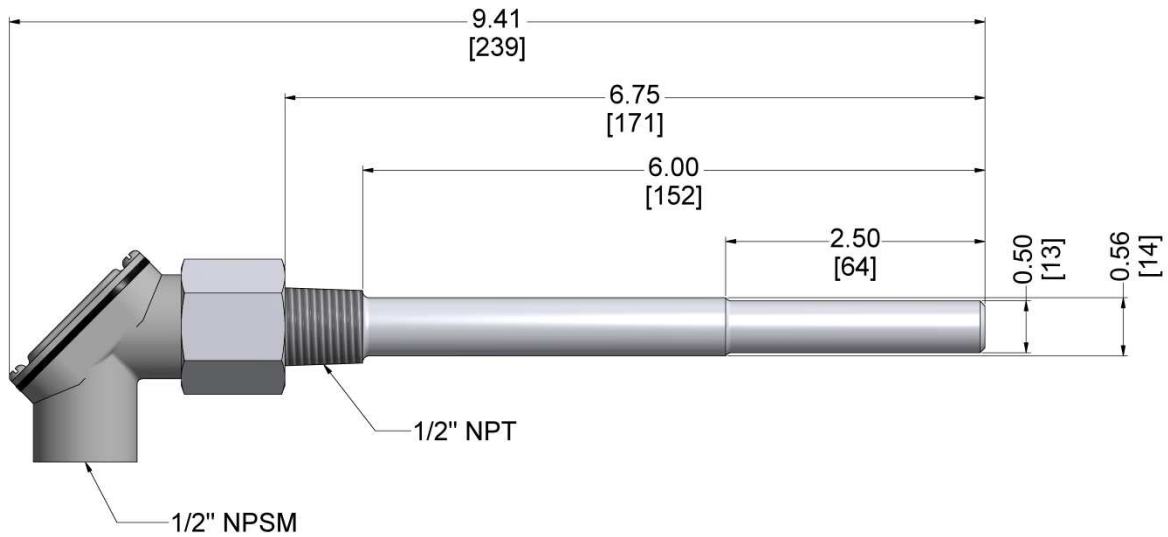

QAE2012.903, QAE2012.9002

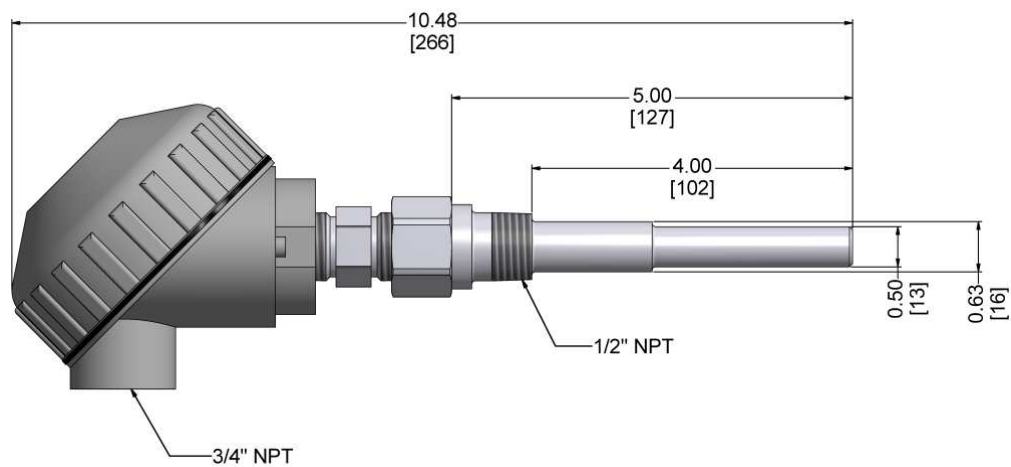

Dimensions (continued)

Dimensions in inches; millimeters in brackets

QAC22

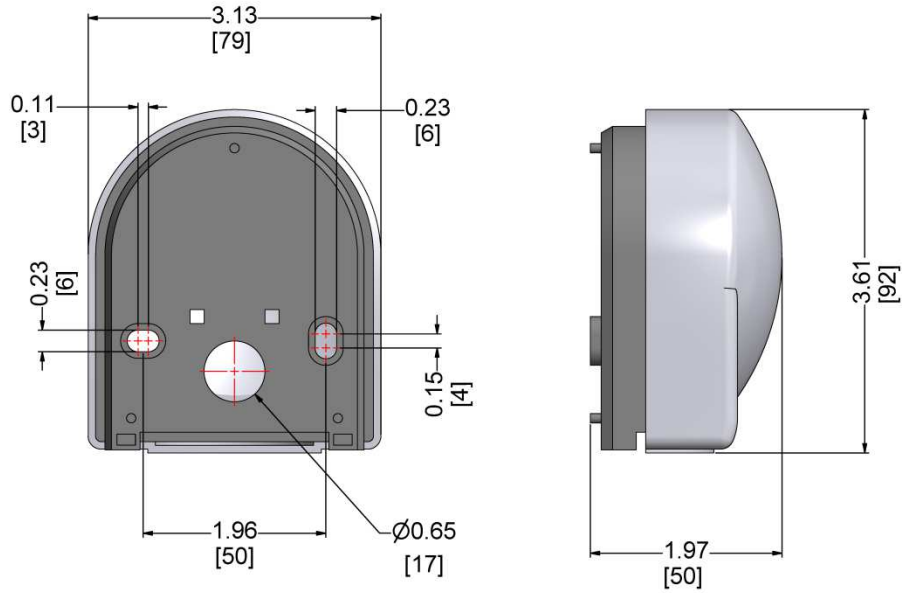

QAM-P210

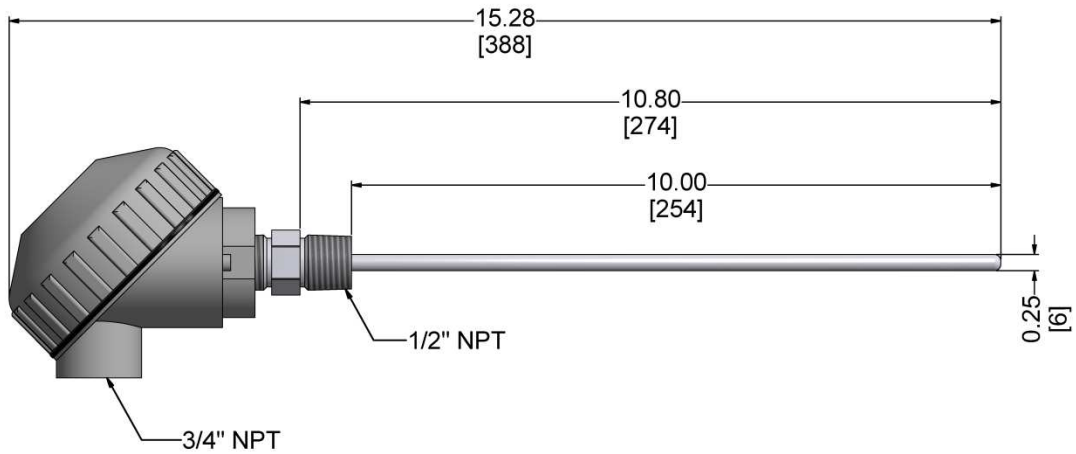

Appendix A

Resistance vs. Temperature Charts

Pt100, 385 characteristic (QAE2012.903, QAE2020.001)

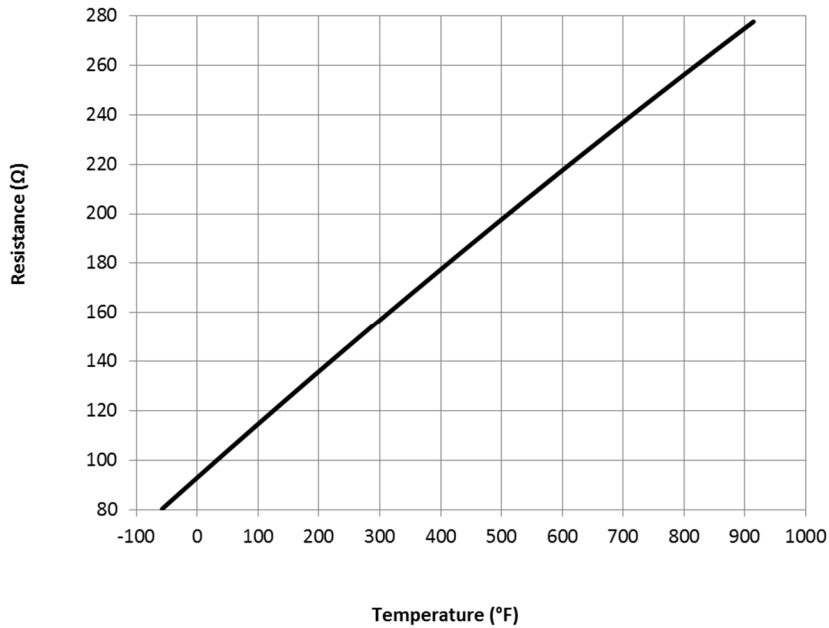

Pt1000, 385 characteristic (QAE2012.001, 544-577-25, 544-577-40, 544-577-60, QAE2012.9002, QAM-P210)

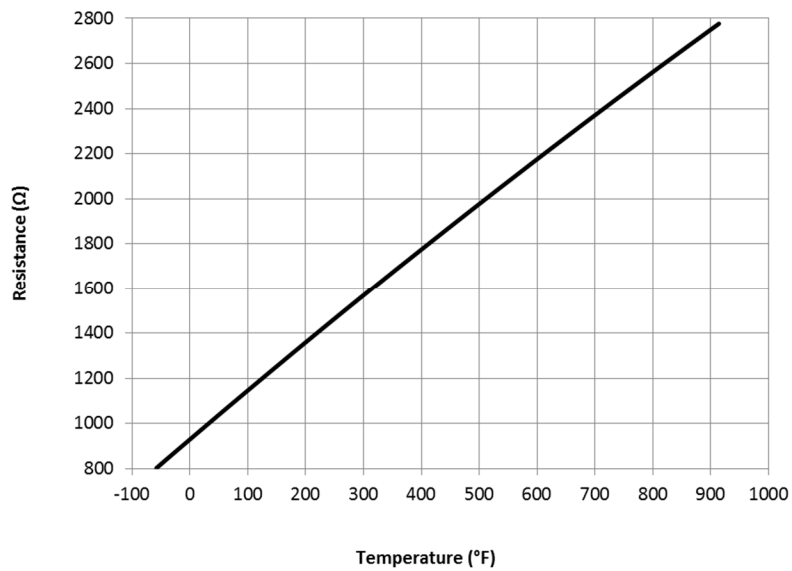

Appendix A (continued)

Resistance vs. Temperature Charts

Ni1000, LG characteristic (QAE2020.005, QAE2020.010, QAE2020.015, QAC22)

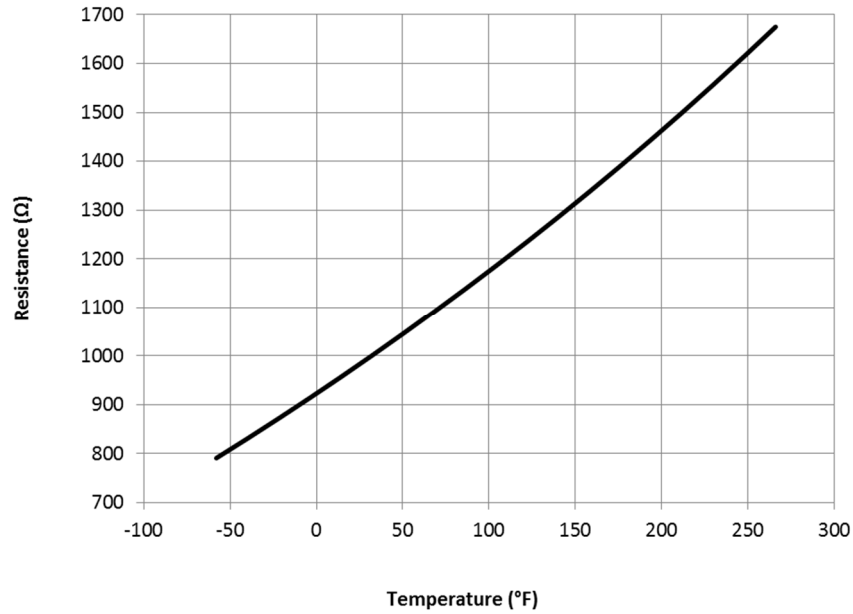

Appendix A (continued)

Accuracy

Pt100 and Pt1000 Sensors (QAE2012.001, QAE2020.001, 544-577-25, 544-577-40, 544-577-60, QAE2012.903, QAE2012.9002, QAM-P210)

$$\text{Accuracy} = \pm [0.54 + (0.005 \times |T - 32|)]$$

T = Temperature in degrees Fahrenheit

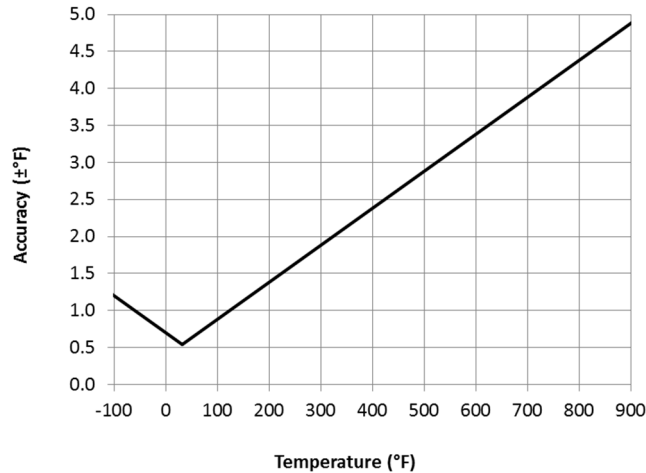

Ni1000 Sensors (QAE2020.005, QAE2020.010, QAE2020.015, QAC22)

$$\begin{aligned} \text{For } T < 32: \text{ Accuracy} &= \pm [0.72 + (0.028 \times |T - 32|)] \\ \text{For } T > 32: \text{ Accuracy} &= \pm [0.72 + (0.007 \times |T - 32|)] \end{aligned}$$

T = Temperature in degrees Fahrenheit

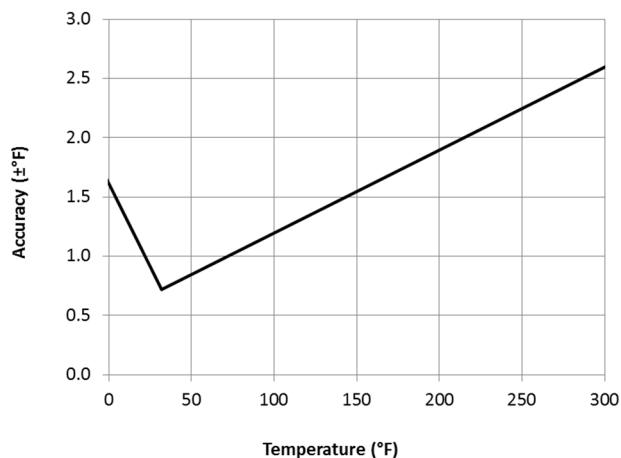

Information in this publication is based on current specifications. The company reserves the right to make changes in specifications and models as design improvements are introduced. Product or company names mentioned herein may be the trademarks of their respective owners. © 2017 SCC Inc.