

TS Series

TS... Protocol Converter

for use with LMV3..., LMV5..., RWF... and TS Series Controls

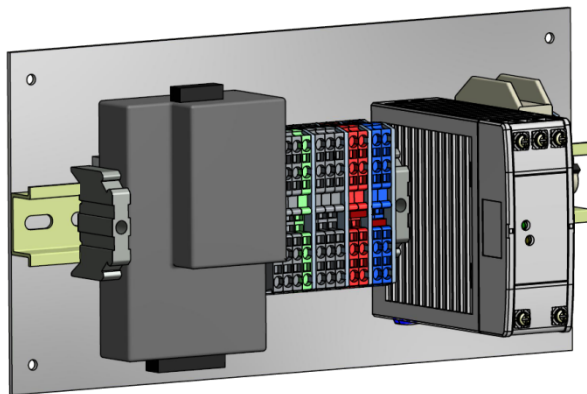

Standard

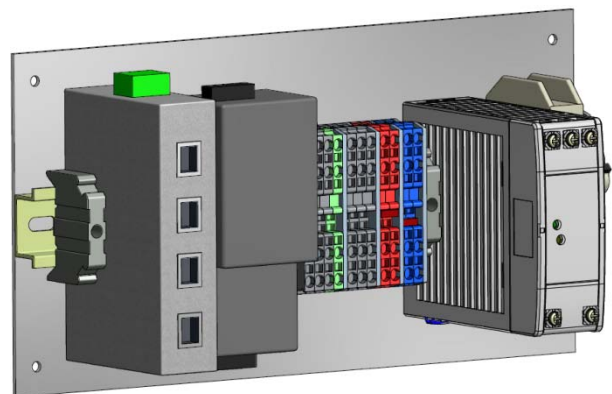

With Ethernet Switch

Description

TS... series protocol converters provide flexible communication interface options to the building management system (BMS) to provide streamlined data collection and monitoring.

Table of Contents

Certifications	5
Compatible Controls and Protocols	6
Available Ports	7
Protocol Selection	8
Physical Connections	9
Diagnostic LEDs.....	10
Web-Based Configuration Utility.....	11
Establishing a Connection	11
Interface	12
Adding a Device.....	13
Adding a TS Series Lead/Lag Master	15
Protocol Configuration Parameters - BACnet/IP	16
Protocol Configuration Parameters - BACnet MS/TP	17
Protocol Configuration Parameters - Metasys N2.....	17
Protocol Configuration Parameters - Modbus TCP/IP	18
Protocol Configuration Parameters - LonWorks.....	18
Clearing All Profiles From Memory.....	18
Changing Network Settings.....	19
Diagnostics and Debugging.....	20
BACnet.....	21
BACnet/IP	21
BACnet MS/TP	21
BACnet Protocol Implementation Conformance Statement (PICS).....	21
BACnet/IP BBMD (BACnet/IP Broadcast Management Device)	22
Metasys N2.....	23
LonWorks.....	24
Service Pin	24
Uploading XIF File	24
Application Examples	25
LMV5 to Any Protocol	25
Introduction	25
Procedure.....	25
BACnet/IP, BACnet MS/TP, Metasys N2 or Modbus TCP/IP Topology.....	26
LonWorks Topology	27
LMV5 and RWF55 to BACnet/IP or Modbus TCP/IP (no RS-232 to RS-485 converter)	28
Introduction	28
Procedure.....	28
BACnet/IP or Modbus TCP/IP Topology.....	29

Table of Contents (continued)

LMV5 and RWF55 to Any Protocol (using RS-232 to RS-485 converter)	30
Introduction	30
Procedure.....	30
BACnet/IP, BACnet MS/TP, Metasys N2 or Modbus TCP/IP Topology.....	31
LonWorks Topology	31
6x LMV5 to Any Protocol	32
Introduction	32
Procedure.....	32
BACnet/IP, BACnet MS/TP, Metasys N2 or Modbus TCP/IP Topology.....	33
LonWorks Topology	34
4x LMV3 and 4x RWF55 to Any Protocol	35
Introduction	35
Procedure.....	35
BACnet/IP or Modbus TCP/IP Topology.....	36
BACnet/IP, BACnet MS/TP, Metasys N2 or Modbus TCP/IP Topology.....	37
LonWorks Topology	38
Total Boiler Room Example: 2x LMV5, 2x RWF55 and TS Series Deaerator/Surge Tank Master to Any Protocol.....	39
Introduction	39
Procedure.....	39
BACnet/IP, BACnet MS/TP, Metasys N2 or Modbus TCP/IP Topology.....	40
LonWorks Topology	41
Total Boiler Room Example: 2x LMV3, 2x RWF10, 2x RWF55 and 2x TS Series Touchscreen Kit to Any Protocol	42
Introduction	42
Procedure.....	42
BACnet/IP, BACnet MS/TP, Metasys N2 or Modbus TCP/IP Topology.....	43
LonWorks Topology	44
Total Boiler Room Example: TS Series Lead/Lag Master to Any Protocol	45
Introduction	45
Procedure.....	45
BACnet/IP, BACnet MS/TP, Metasys N2 or Modbus TCP/IP Topology.....	46
LonWorks Topology	47
Total Boiler Room Example: TS Series Lead/Lag Master and 2x TS Series Touchscreen Kit to Any Protocol	48
Introduction	48
Procedure.....	48
BACnet/IP, BACnet MS/TP, Metasys N2 or Modbus TCP/IP Topology.....	49
LonWorks Topology	50

Table of Contents (continued)

Point List BACnet and Metasys N2 - LMV3	51
Point List LonWorks - LMV3	53
Point List BACnet and Metasys N2 - LMV5	55
Point List LonWorks - LMV5	59
Point List BACnet and Metasys N2 - RWF10	63
Point List LonWorks - RWF10	63
Point List BACnet and Metasys N2 - RWF40	64
Point List LonWorks - RWF40	66
Point List BACnet and Metasys N2 - RWF55	68
Point List LonWorks - RWF55	70
Point List BACnet and Metasys N2 - TS Series Deaerator/Surge Tank Master	72
Point List LonWorks - TS Series Deaerator/Surge Tank Master	74
Point List BACnet and Metasys N2 - TS Series Touchscreen Kit	76
Point List LonWorks - TS Series Touchscreen Kit	85
Point List BACnet and Metasys N2 - TS Series Lead/Lag Master	94
Point List LonWorks - TS Series Lead/Lag Master	95
Point List BACnet and Metasys N2 - TS Series Lead/Lag Boiler	96
Point List LonWorks - TS Series Lead/Lag Boiler	98
Point List Modbus TCP/IP	100
Appendix – LMV5 Wiring	101
Appendix – RS-485 Wiring	102
Appendix – LMV3 Configuration for Modbus	103
Appendix – LMV5 Configuration for Modbus	104
Appendix – RWF55 Configuration for Modbus	105
Appendix – RWF40 Configuration for Modbus	106
Appendix – RWF10 Configuration for Modbus	107
Appendix – TS Series Configuration	108
Appendix – LMV3 Native Modbus/RTU Mapping	109
Appendix – LMV5 Native Modbus/RTU Mapping	111
Appendix – RWF55 Native Modbus/RTU Mapping	116
Appendix – RWF40 Native Modbus/RTU Mapping	118
Appendix – RWF10 Native Modbus/RTU Mapping	120
Appendix – LMV Phases	121
Appendix – LMV3 Error Codes	122
Appendix – LMV5 Lockout/Error Codes	125
Appendix – Changing Windows IP Address	128
Appendix – BACnet PICS	131

Certifications

- **BTL MARK – BACNET TESTING LABORATORY**



BACnet is a registered trademark of ASHRAE. ASHRAE does not endorse, approve or test products for compliance with ASHRAE standards. Compliance of listed products to requirements of ASHRAE Standard 135 is the responsibility of the BTL. LonMark International. BTL is a registered trademark of the BTL Testing Laboratory.

The BTL Mark is a symbol that indicates that a product has passed a series of rigorous tests conducted by an independent laboratory which verifies that the product correctly implements the BACnet features claimed in the listing. The mark is a symbol of a high-quality BACnet product.

- **LONMARK CERTIFICATION**



LonMark International is the recognized authority for certification, education, and promotion of interoperability standards for the benefit of manufacturers, integrators and end users. LonMark International has developed extensive product certification standards and tests to provide the integrator and user with confidence that products from multiple manufacturers utilizing LonMark devices work together.

Compatible Controls and Protocols

The TS Series Protocol Converter can connect any combination or quantity of supported controls and convert the data into one of the supported protocols. A web-based configuration utility is used to make configuration changes.

Controls

- LMV5... (via AZL...)
- LMV3... (via OCI412.10)
- RWF10 (with Modbus option)
- RWF40 (with Modbus option)
- RWF55
- TS Series Deaerator/Surge Tank Master
- TS Series Touchscreen Kit
- TS Series Lead/Lag Master

Protocols

- BACnet/IP
- BACnet MS/TP
- Modbus TCP/IP
- Metasys N2
- LonWorks

Available Ports

TS-PX4

This model has the following ports:

- HOST port: RS-485
- FIELD port: RS-485 (BACnet MS/TP or Metasys N2 protocols)
- ETHERNET port (BACnet/IP or Modbus TCP/IP protocols)

TS-PL4

This model has the following ports:

- HOST port: RS-485
- FIELD port: LonWorks (LonWorks protocol)
- ETHERNET port

TS-PX2

This model has the following ports:

- HOST port: RS-232
- FIELD port: RS-485 (BACnet MS/TP or Metasys N2 protocols)
- ETHERNET port (BACnet/IP or Modbus TCP/IP protocols)

TS-PL2

This model has the following ports:

- HOST port: RS-232
- FIELD port: LonWorks (LonWorks protocol)
- ETHERNET port

Serial devices (LMV... and RWF...) normally connect to the HOST port. They can also connect to the FIELD port when the selected protocol uses the ETHERNET port. Ethernet devices (TS Series) can connect to the ETHERNET port regardless of which protocol is selected.

Each model comes prewired as a kit with a circuit breaker, DC power supply and optional Ethernet switch. Models TS-PX2 and TS-PL2 also come with a prewired cable from the HOST RS-232 port to connect directly to the AZL.... If the TS-P... is ordered as part of a TS Series Lead/Lag Master, TS Series Deaerator/Surge Tank Master or TS Series Touchscreen Kit, it will come preinstalled and configured as part of that assembly.

Protocol Selection

Models TS-PX4 and TS-PX2 can be configured for any of the following protocols:

- BACnet/IP
- BACnet MS/TP
- Modbus TCP/IP
- Metasys N2

To select the protocol, use the 'S' bank of DIP switches located on the upper left side of the device. The OFF position is when the DIP switch is set closest to the outside of the box. Following a protocol selection change, the device will automatically reboot.

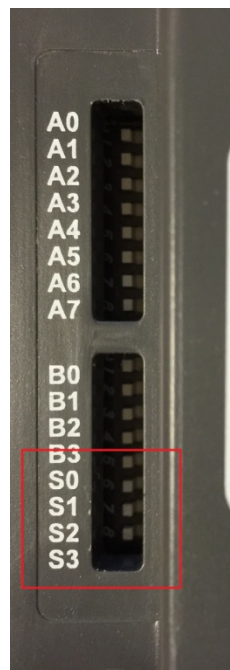

Profile	S0	S1	S2	S3
BACnet/IP	OFF	OFF	OFF	OFF
BACnet MS/TP	ON	OFF	OFF	OFF
Metasys N2	OFF	ON	OFF	OFF
Modbus TCP/IP (all nodes connected to HOST port)	ON	ON	OFF	OFF
Modbus TCP/IP (all nodes connected to FIELD port)	OFF	OFF	ON	OFF
Modbus TCP/IP (odd nodes to HOST port, even nodes to FIELD port)	ON	OFF	ON	OFF

Models TS-PL4 and TS-PL2 are configured for LonWorks and cannot be changed.

Physical Connections

The protocol converter communicates with the connected equipment via Modbus. Multiple different devices can connect to the protocol converter. Connect any RS-485 devices in a daisy-chain with termination at the end of the chain (typically a 120-Ohm resistor).

Device Communication Protocols and Physical Mediums

Device	Protocol	Physical Medium
LMV3... (via OCI412.10)	Modbus/RTU	RS-485
LMV5... (via AZL...)	Modbus/RTU	RS-232
RWF10 (with Modbus)	Modbus/RTU	RS-485
RWF40 (with Modbus)	Modbus/RTU	RS-485
RWF55	Modbus/RTU	RS-485
TS Series Deaerator/Surge Tank Master	Modbus TCP/IP	Ethernet
TS Series Touchscreen Kit	Modbus TCP/IP	Ethernet
TS Series Lead/Lag Master	Modbus/RTU	RS-485

Each connected device must have a unique Modbus address assigned between 1 and 255. All serial devices connected must have matching baud rates, data bits, stop bits and parity settings. See the appendices for Modbus configuration details for each device.

The protocol converter has three ports, labeled HOST, FIELD and ETHERNET. The format of the HOST and FIELD ports is dependent upon the model number of the device (see *Available Ports* for additional detail).

HOST Port



ETHERNET Port



FIELD Port (TS-PX4, TS-PX2)

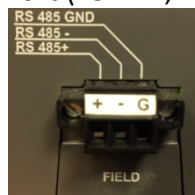

FIELD Port (TS-PL4, TS-PL2)



Diagnostic LEDs

The protocol converter has six LEDs that indicate the current status.

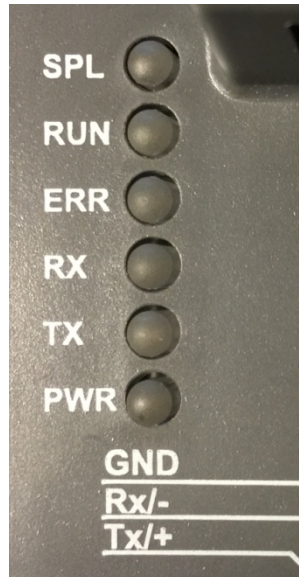

SPL - Indicates that the protocol converter is offline (unprogrammed).

RUN - Begins flashing 20 seconds after power to indicate normal operation.

ERR - Indicates that there is a system error present. Use the web-based configuration utility to determine the source of the error.

RX - Indicates that a message has been received on the HOST port.

TX - Indicates that a message has been sent on the HOST port.

PWR - Indicates that the device is powered on.

During normal communication with a serial device, the **RX** and **TX** LEDs will flash in alternation to indicate that communication is active.

Removing the cover of the protocol converter exposes the **RX** and **TX** LEDs for the FIELD port. This could be helpful in troubleshooting a bad connection.

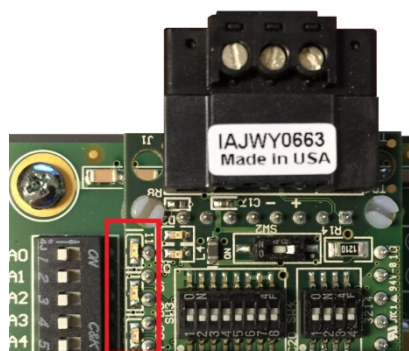

Web-Based Configuration Utility

The protocol converter is configured using a web-based configuration utility. This requires that a device with a web browser is connected to the same network as the protocol converter and can communicate with it.

Establishing a Connection

The default network settings for the protocol converter are:

- **IP Address** - 192.168.1.70
- **Subnet Mask** - 255.255.255.0

It may be necessary to change your device IP address to a static address in the 192.168.1.x range (such as 192.168.1.99) in order to establish communication. See *Appendix - Changing Windows IP Address* for additional detail.

If the IP address has been changed, it will be necessary to keep the new address noted since it will be needed to establish communication in the future.

Web-Based Configuration Utility (continued)

Interface

The first step is to open a web browser. Next, navigate to **http://192.168.1.70** (or the new IP address if it has been changed). The utility will redirect automatically to the configuration parameters.

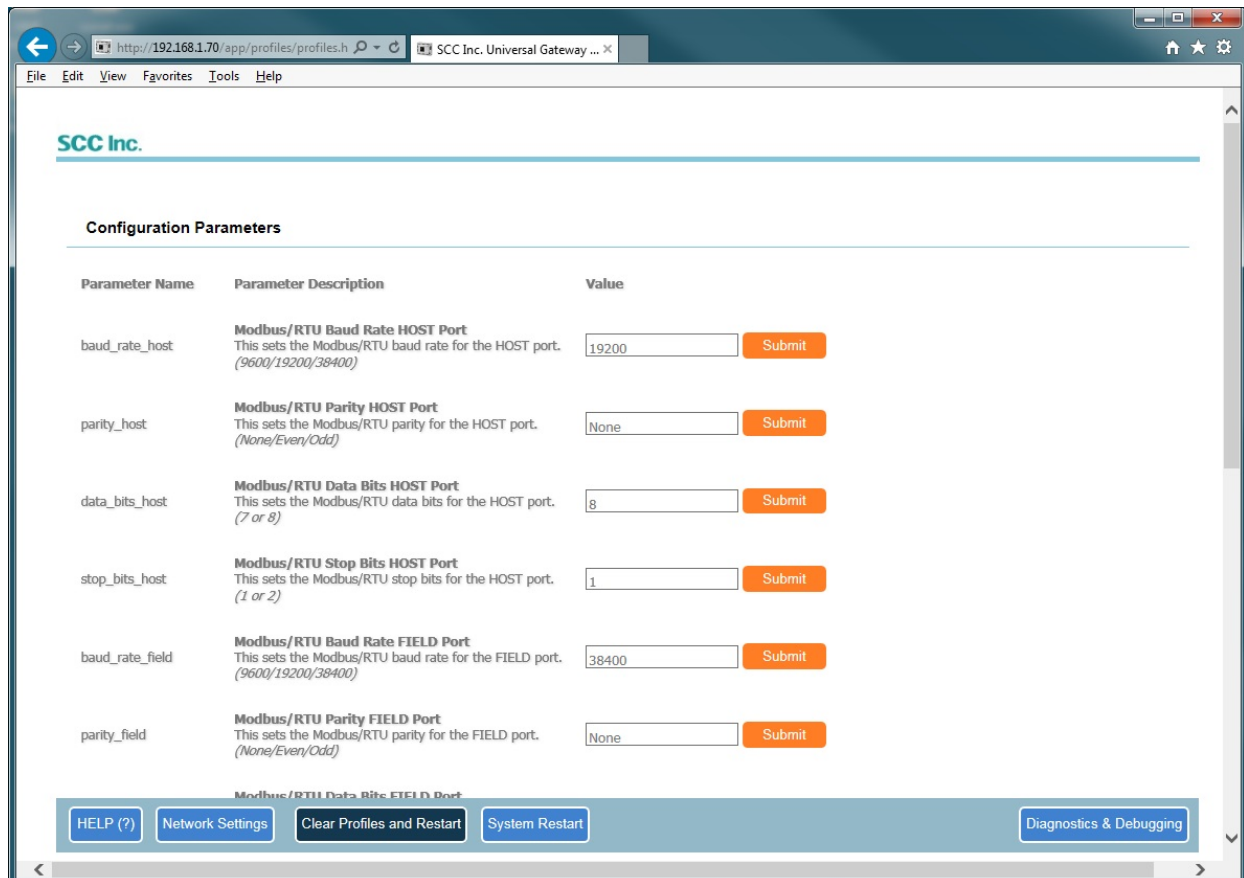

Web-Based Configuration Utility (continued)

Adding a Device

To add a device, scroll down to the bottom of the screen and click **Add**.

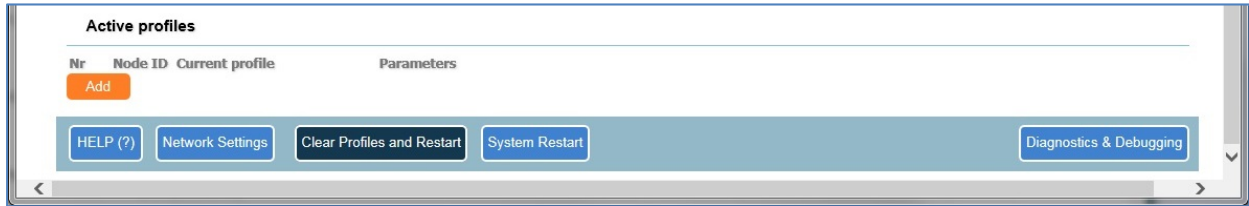

Click on the 'Current Profile' dropdown to expand the list. Choose the device to configure.

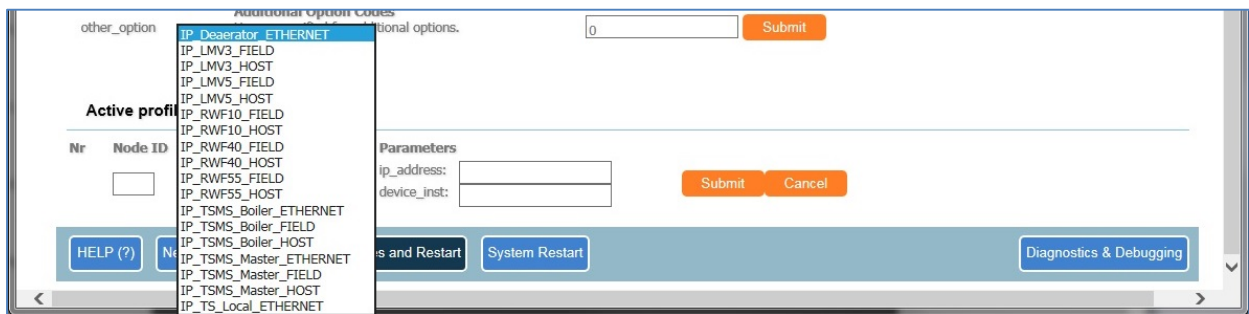
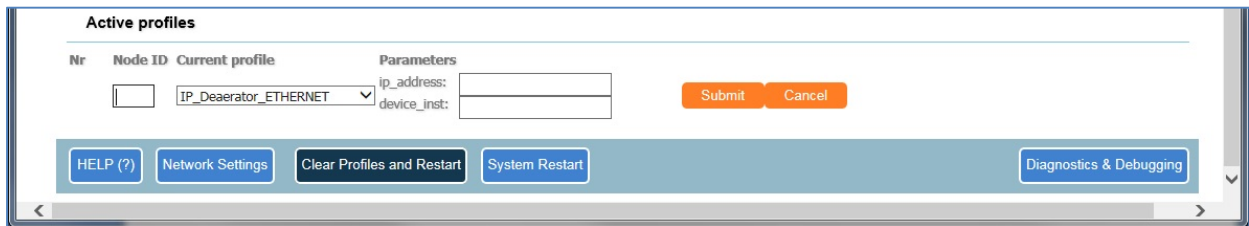

Web-Based Configuration Utility (continued)

Once the device is selected, enter the Modbus address in the 'Node ID' field. This must be a unique address. For devices connected to the ETHERNET port, enter any unique number. A good practice in this case is to use numbers 200 or greater since these are unlikely to be assigned as Modbus addresses.

Depending upon the profile and protocol, different parameters will need to be entered.

- **ip_address** - Required if the device is connected using the ETHERNET port. This is the IP address of the connected device.
- **device_inst** - Required for BACnet protocols. Each connected device must have a unique device instance.
- **boiler_id** - Required for Lead/Lag Master boiler profiles. Normally this is done automatically when a Lead/Lag Master is configured but can be done manually if non-sequential device instances are desired.
- **boiler_qty** - Required for Lead/Lag Masters. Indicates how many boilers are connected so that profiles for each can be created. The device instances are sequential (i.e. if master is 1000, boiler 1 is 1001, etc.).

When all of the required information is entered, click **Submit**. The new device should now appear under the 'Active profiles' heading.

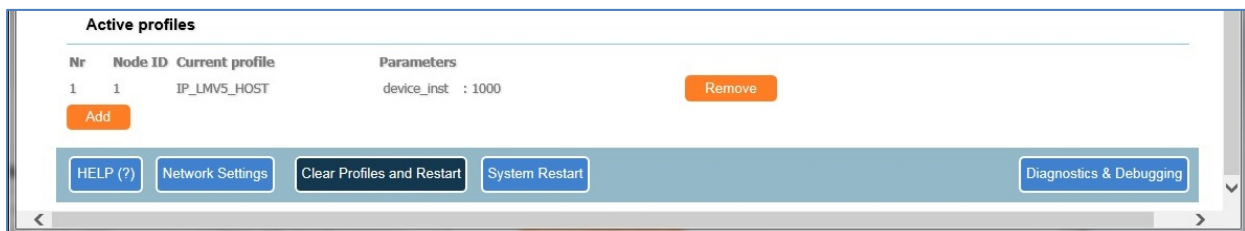

Repeat for each device to connect. When finished, click **System Restart** to activate the new profiles.

Web-Based Configuration Utility (continued)

Adding a TS Series Lead/Lag Master

As with any other device, scroll down to the bottom of the screen and click **Add**. In the dropdown menu, select the device name containing 'TSMS_Master'. Choose the port that corresponds to the physical connection of the TS Series Lead/Lag Master to the protocol converter. In most cases, this will be the HOST port connected via RS-485.

Nr	Node ID	Current profile	Parameters
200		IP_TSMS_Master_HOST	device_inst: 1000 boiler_qty: 3

Enter a unique and unused number for the node ID. Enter the device instance and the quantity of boilers. The boiler device instances will increment sequentially after the master device instance. Click **Submit**.

Nr	Node ID	Current profile	Parameters	
1	200	IP_TSMS_Boiler_HOST	device_inst : 1001 boiler_id : 1	Remove
2	200	IP_TSMS_Boiler_HOST	device_inst : 1002 boiler_id : 2	Remove
3	200	IP_TSMS_Boiler_HOST	device_inst : 1003 boiler_id : 3	Remove
4	200	IP_TSMS_Master_HOST	device_inst : 1000 boiler_qty : 3	Remove

Note that the boiler profiles were automatically created with sequential device instances. Click **System Restart** to activate the new profiles.

Web-Based Configuration Utility (continued)

Protocol Configuration Parameters - BACnet/IP

Parameters that apply to all profiles or are general to the protocol are set here. After changing a value, click **Submit** to apply the change.

baud_rate_host - This sets the Modbus/RTU baud rate for the HOST port (9600/19200/38400).

parity_host - This sets the Modbus/RTU parity for the HOST port (None/Odd/Even).

data_bits_host - This sets the Modbus/RTU data bits for the HOST port (7 or 8).

stop_bits_host - This sets the Modbus/RTU stop bits for the HOST port (1 or 2).

baud_rate_field - This sets the Modbus/RTU baud rate for the FIELD port (9600/19200/38400).

parity_field - This sets the Modbus/RTU parity for the FIELD port (None/Odd/Even).

data_bits_field - This sets the Modbus/RTU data bits for the FIELD port (7 or 8).

stop_bits_field - This sets the Modbus/RTU stop bits for the FIELD port (1 or 2).

bac_ip_port - This sets the BACnet/IP port, default is 47808 (1-65535).

network_number - This sets the BACnet network number, default is 50 (1-65535).

bac_cov_option - This enables/disables the BACnet COV option, default is disabled (COV_Enable or COV_Disable).

bac_bbmd_option - This enables/disables the BACnet/IP BBMD option, default is disabled (BBMD or -). See *Appendix - Configuring BBMD* for additional detail.

watchdog_time - Remote command required refresh time, default is 60 seconds (0-999).

other_option - Enables additional options in the Lead/Lag Master, default is 0 (0-999). See Technical Document TS-8000 for additional detail.

Web-Based Configuration Utility (continued)

Protocol Configuration Parameters - BACnet MS/TP

Parameters that apply to all profiles or are general to the protocol are set here. After changing a value, click **Submit** to apply the change.

mac_address - This sets the BACnet MS/TP MAC address, default is 11 (1-254).

bac_max_master - This sets the BACnet MS/TP max master, default is 127 (1-127).

baud_rate_mstp - This sets the BACnet MS/TP baud rate for the FIELD port (9600/19200/38400).

parity_mstp - This sets the BACnet MS/TP parity for the FIELD port (None/Odd/Even).

data_bits_mstp - This sets the BACnet MS/TP data bits for the FIELD port (7 or 8).

stop_bits_mstp - This sets the BACnet MS/TP stop bits for the FIELD port (1 or 2).

baud_rate_host - This sets the Modbus/RTU baud rate for the HOST port (9600/19200/38400).

parity_host - This sets the Modbus/RTU parity for the HOST port (None/Odd/Even).

data_bits_host - This sets the Modbus/RTU data bits for the HOST port (7 or 8).

stop_bits_host - This sets the Modbus/RTU stop bits for the HOST port (1 or 2).

network_number - This sets the BACnet network number, default is 50 (1-65535).

bac_cov_option - This enables/disables the BACnet COV option, default is disabled (COV_Enable or COV_Disable).

watchdog_time - Remote command required refresh time, default is 60 seconds (0-999).

other_option - Enables additional options in the Lead/Lag Master, default is 0 (0-999). See Technical Document TS-8000 for additional detail.

Protocol Configuration Parameters - Metasys N2

Parameters that apply to all profiles or are general to the protocol are set here. After changing a value, click **Submit** to apply the change.

baud_rate_host - This sets the Modbus/RTU baud rate for the HOST port (9600/19200/38400).

parity_host - This sets the Modbus/RTU parity for the HOST port (None/Odd/Even).

data_bits_host - This sets the Modbus/RTU data bits for the HOST port (7 or 8).

stop_bits_host - This sets the Modbus/RTU stop bits for the HOST port (1 or 2).

watchdog_time - Remote command required refresh time, default is 60 seconds (0-999).

other_option - Enables additional options in the Lead/Lag Master, default is 0 (0-999). See Technical Document TS-8000 for additional detail.

Web-Based Configuration Utility (continued)

Protocol Configuration Parameters - Modbus TCP/IP

Parameters that apply to all profiles or are general to the protocol are set here. After changing a value, click **Submit** to apply the change.

The Modbus TCP/IP option works differently than the other protocols. Profiles are not set up, but rather data is simply passed from the HOST or FIELD port directly using the node ID (Modbus address). The DIP switch settings will determine if the HOST, FIELD or a combination of the two ports are passed. See *Protocol Selection* for additional detail.

mod_baud_rate - This sets the Modbus/RTU baud rate for the configured port (9600/19200/38400).

mod_parity - This sets the Modbus/RTU parity for the configured port (None/Odd/Even).

mod_data_bits - This sets the Modbus/RTU data bits for the configured port (7 or 8).

mod_stop_bits - This sets the Modbus/RTU stop bits for the configured port (1 or 2).

Protocol Configuration Parameters - LonWorks

Parameters that apply to all profiles or are general to the protocol are set here. After changing a value, click **Submit** to apply the change.

baud_rate_host - This sets the Modbus/RTU baud rate for the HOST port (9600/19200/38400).

parity_host - This sets the Modbus/RTU parity for the HOST port (None/Odd/Even).

data_bits_host - This sets the Modbus/RTU data bits for the HOST port (7 or 8).

stop_bits_host - This sets the Modbus/RTU stop bits for the HOST port (1 or 2).

watchdog_time - Remote command required refresh time, default is 60 seconds (0-999).

other_option - Enables additional options in the Lead/Lag Master, default is 0 (0-999). See Technical Document TS-8000 for additional detail.

Clearing All Profiles From Memory

All configured profiles can be cleared from the protocol converter by clicking **Clear Profiles and Restart** from the configuration screen. Alternatively, each profile can also be individually removed by clicking **Remove** under 'Active profiles'.

Web-Based Configuration Utility (continued)

Changing Network Settings

From the configuration screen, click **Network Settings** to view or edit the network settings. Note that the IP address cannot be changed when communicating to a TS Series Lead/Lag Master that is connected to TS Series Touchscreen Kits since the default IP addresses are necessary for communication.

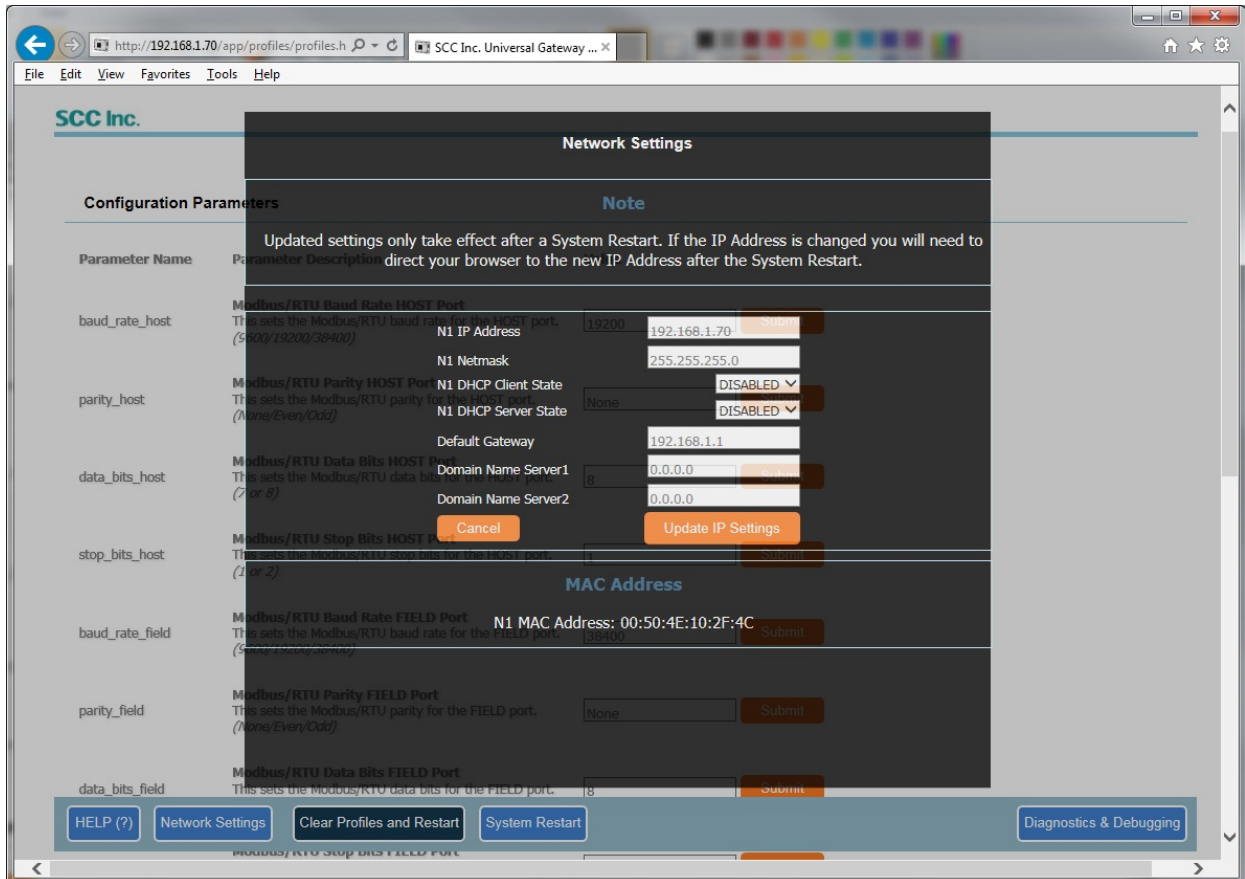

After making changes, click **Update IP Settings** to apply.

Web-Based Configuration Utility (continued)

Diagnostics and Debugging

From the configuration screen, click **Diagnostics & Debugging** to display the diagnostic home screen. Use the navigation pane on the left to view the four diagnostic and debugging sections.

About - Contains device data.

Setup - Allows uploading and downloading of system files.

View - Contains operation data useful for troubleshooting.

User Messages - Contains the error, info, driver and combined message logs. Note that messages for each log type can be cleared by clicking **Clear Messages**.

The screenshot displays the web-based configuration utility for the SCC Inc. Universal Gateway 15F1. The browser address bar shows the URL: http://192.168.1.70/htm/fsgui.htm#2_OID. The page title is "SCC Inc. Universal Gateway 15F1".

The interface is divided into a left navigation pane and a main content area. The navigation pane includes a "Navigation" section with the following items:

- SCC Inc. Universal Gateway 15F1
 - About
 - Setup
 - View
 - User Messages

The main content area shows the "Status" tab selected. Below the tab are three sub-tabs: "Status", "Settings", and "Info Stats". The "Status" tab displays a table of system parameters:

Name	Value
Driver_Configuration	PCC1043
DCC_Version	V1.00b (C)
Kernel_Version	V6.21b (B)
Release_Status	Normal
Build_Revision	208
Build_Date	Fri Jun 26 13:40:54 2015 +0200
BIOS_Version	2.3.3
FieldServer_Model	ProtoCessor FFP485
Carrier Type	485 Carrier
Data_Points_Used	0
Data_Points_Max	1500
Application Memory:	
Memory_Percent_Used	0.31%
Memory_Used	316 kB
Memory_Available	100,753 kB
Avg_Cycle_Time	1
Min_Cycle_Time	1
Max_Cycle_Time	104
Cache_Usage_(RDB)	0
Cache_Usage_(MPP)	0

At the bottom of the page, there are several buttons: "Home", "HELP (F1)", "Contact Us", "System Restart", "System Time Synch", and "Reset Cycle Times".

BACnet

Models TS-PX... support both BACnet/IP and BACnet MS/TP.

BACnet/IP

BACnet/IP uses Ethernet as the physical medium and communicates using the UDP transport layer on port 47808 (BAC0 in hexadecimal) by default. The protocol converter can be configured as a BACnet/IP Broadcast Management Device. See section *BACnet/IP BBMD (BACnet/IP Broadcast Management Device)* for additional detail.

BACnet MS/TP

BACnet MS/TP uses RS-485 as the physical medium and communicates using a method known as 'master-slave token passing'. With this method, a device that wishes to initiate a poll requests the token. Only one device at any time can possess the token. When the device is finished or has reached the message limit, the token is passed to the next device that has requested it.

Up to 128 devices can be installed on a single network. Supported baud rates are 9600, 19200 and 38400. See *Appendix - RS-485 Wiring* for additional detail.

BACnet Protocol Implementation Conformance Statement (PICS)

See *Appendix - BACnet PICS* for the complete BACnet Protocol Implementation Conformance Statement.

BACnet (continued)

BACnet/IP BBMD (BACnet/IP Broadcast Management Device)

Using BACnet/IP Broadcast Management Device (BBMD), any received broadcast messages will be sent as directed messages to any other connected BBMD devices. For this to work, each BBMD must be configured with the IP addresses of any other connected BBMDs using a Broadcast Distribution Table (BDT).

To create a BDT, use Notepad or any text editor to create a file in the format shown below. Use a new line for each entry and separate data fields with a comma. Save the file with the filename 'bdt.ini'.

```
// bdt.ini
// The format of this table must be:
//
// BBMD IP address , BBMD port , BBMD subnet mask
//
24.90.48.179 , 47808 , 255.255.255.255
64.80.115.156 , 47808 , 255.255.255.255
```

To load the BDT, open the web-based configuration utility and navigate to the diagnostics home screen (see *Web-Based Configuration Utility → Diagnostics and Debugging* for additional detail). Expand **Setup** in the left pane, then click **File Transfer**. In the right pane, click the **General** tab. Click **Browse...** and select the created 'bdt.ini' file. Click **Submit** to load the BDT file.

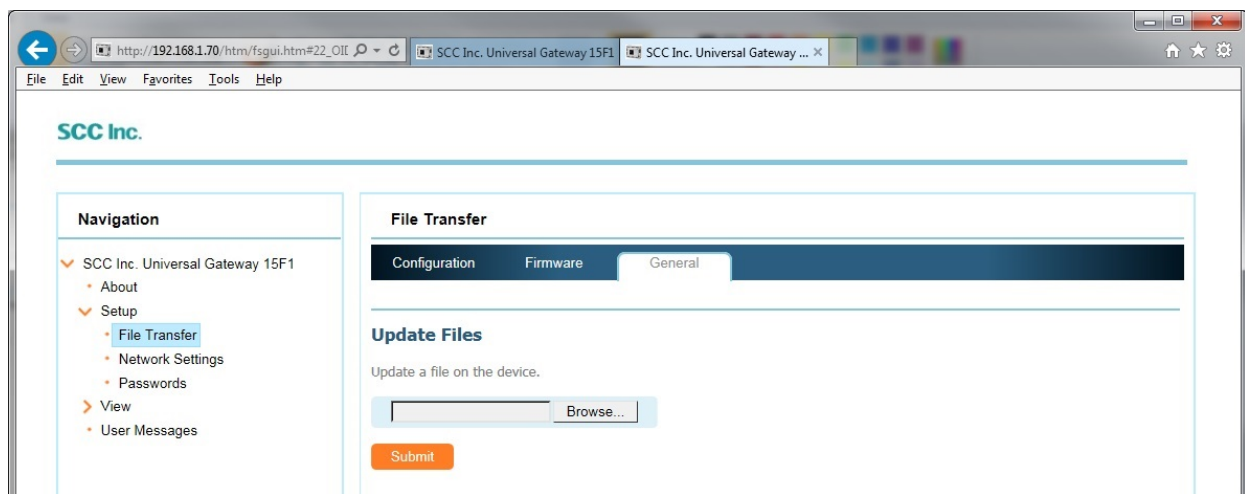

Metasys N2

Models TS-PX... support Metasys N2.

Metasys N2 uses RS-485 as the physical medium. The maximum number of devices that can be installed on a single network varies depending upon the model of controller. The only supported baud rate is 9600. See *Appendix - RS-485 Wiring* for additional detail.

LonWorks

Models TS-PL... support the LonWorks protocol via the FIELD port. LonWorks uses the FTT-10A transceiver. The LonWorks network is polarity insensitive and supports free topology wiring (i.e. star, bus or daisy-chain wiring are all acceptable). When using LonWorks, the device must be commissioned on the LonWorks network using a commissioning tool.

Service Pin

To aid with commissioning, a service pin is provided to broadcast the network information of the protocol converter. This is located under the case and can be depressed using a small flathead screwdriver.



Uploading XIF File

If it is necessary to supply an XIF file during commissioning, this can be uploaded from the device. To do so, open a web browser and navigate to **http://192.168.1.70/fserver.xif** (or the new IP address if it has been changed). Save the file when prompted.

```
File: fserver.xif generated by LonDriver Revision 1.30(d), XIF Version 4.0
Copyright (c) 2000-2012 by FieldServer Technologies
All Rights Reserved. Run on Thu Jan 1 00:00:00 1970

90:00:95:47:1E:02:04:7C
2 15 1 4 0 14 11 3 3 12 14 11 11 11 3 0 16 63 0 1 11 4
32 5 19 13 28 0 0 15 5 3 109 63
1 7 1 0 4 4 4 15 200 0
78125 0 0 0 0 0 0 0 0 0 0
0 0 0 0 0 0 0 1 5 8 5 12 14 15
*
"FFP-Lon Demo

VAR nviAnalog_01 0 0 0 0
0 1 63 0 0 0 0 0 0 0 0 0 0
*
51 * 1
4 0 4 0 0
VAR nvoAnalog_01 1 0 0 0
0 1 63 1 0 0 0 0 0 0 0 0 0
*
51 * 1
4 0 4 0 0
VAR nviBinary_01 2 0 0 0
0 1 63 0 0 0 0 0 0 0 0 0 0
*
95 * 2
1 0 0 0 0
1 0 0 1 0
VAR nvoBinary_01 3 0 0 0
0 1 63 1 0 0 0 0 0 0 0 0 0
*
95 * 2
1 0 0 0 0
1 0 0 1 0
```

Application Examples

LMV5 to Any Protocol

Introduction

The LMV5 has a physical RS-232 connection. The only part number that can work with an RS-232 device is the TS-PX2 or TS-PL2. Choose the TS-PX2 for any protocol other than LonWorks.

Procedure

1. Set the DIP switches for the selected profile (see *Protocol Selection* for additional detail). This step is not applicable when using the TS-PL2 for LonWorks.
2. Connect the LMV5 to the HOST port (see *Appendix - LMV5 Wiring* for additional detail).
3. Configure the LMV5 for the desired Modbus address (see *Appendix - LMV5 Configuration for Modbus* for additional detail).
4. Use the web-based configuration utility to set up the LMV5 HOST-port profile.
5. Restart the protocol converter.

Application Examples (continued)

BACnet/IP, BACnet MS/TP, Metasys N2 or Modbus TCP/IP Topology

Scalable HOST-port: No (RS-232 is single-drop)

Scalable FIELD-port: N/A (used for field protocol)

Scalable ETHERNET-port: N/A (used for field protocol)

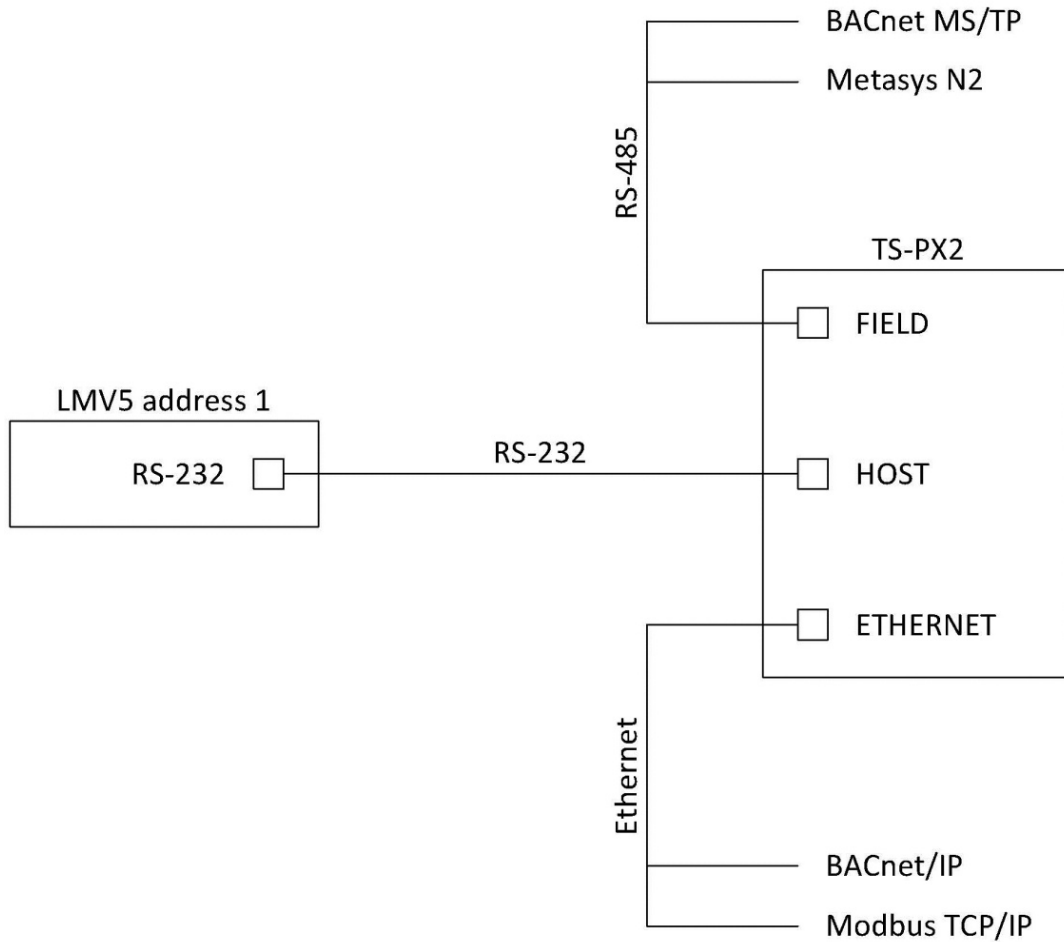

Application Examples (continued)

LonWorks Topology

Scalable HOST-port: No (RS-232 is single-drop)
Scalable FIELD-port: N/A (used for field protocol)
Scalable ETHERNET-port: N/A (used for field protocol)

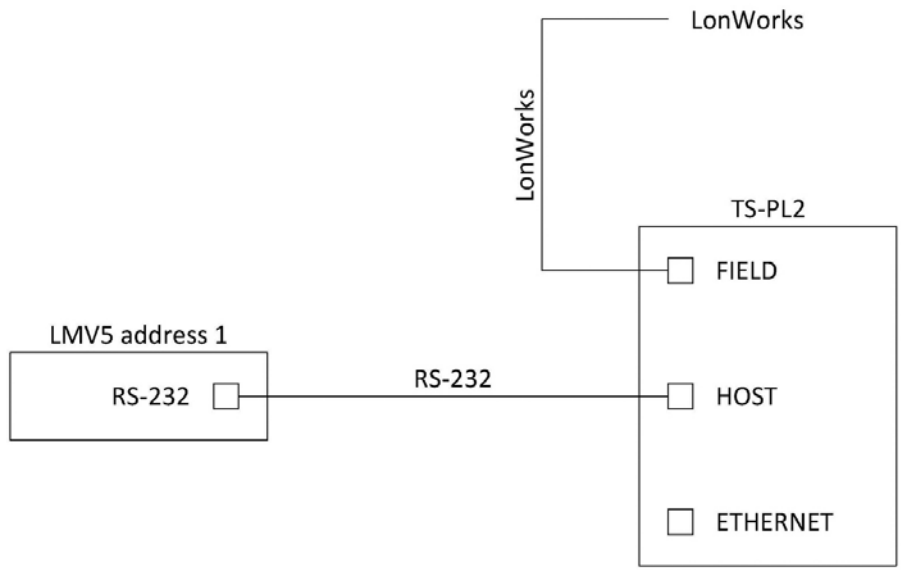

Application Examples (continued)

LMV5 and RWF55 to BACnet/IP or Modbus TCP/IP (no RS-232 to RS-485 converter required)

Introduction

The LMV5 has a physical RS-232 connection and the RWF55 has a physical RS-485 connection. The only part number that can work with an RS-232 device and BACnet/IP or Modbus TCP/IP is the TS-PX2.

Procedure

1. Set the DIP switches for the selected profile (see *Protocol Selection* for additional detail).
2. Connect the LMV5 to the HOST port (see *Appendix - LMV5 Wiring* for additional detail).
3. Configure the LMV5 for the desired Modbus address (see *Appendix - LMV5 Configuration for Modbus* for additional detail).
4. Connect the RWF55 to the FIELD port (see *Appendix - RS-485 Wiring* for additional detail).
5. Configure the RWF55 for the desired Modbus address (see *Appendix - RWF55 Configuration for Modbus* for additional detail).
6. Use the web-based configuration utility to set up the LMV5 HOST-port profile.
7. Use the web-based configuration utility to set up the RWF55 FIELD-port profile.
8. Restart the protocol converter.

Application Examples (continued)

BACnet/IP or Modbus TCP/IP Topology

Scalable HOST-port: No (RS-232 is single-drop)

Scalable FIELD-port: Yes (quantities and device types can be adjusted)

Scalable ETHERNET-port: N/A (used for field protocol)

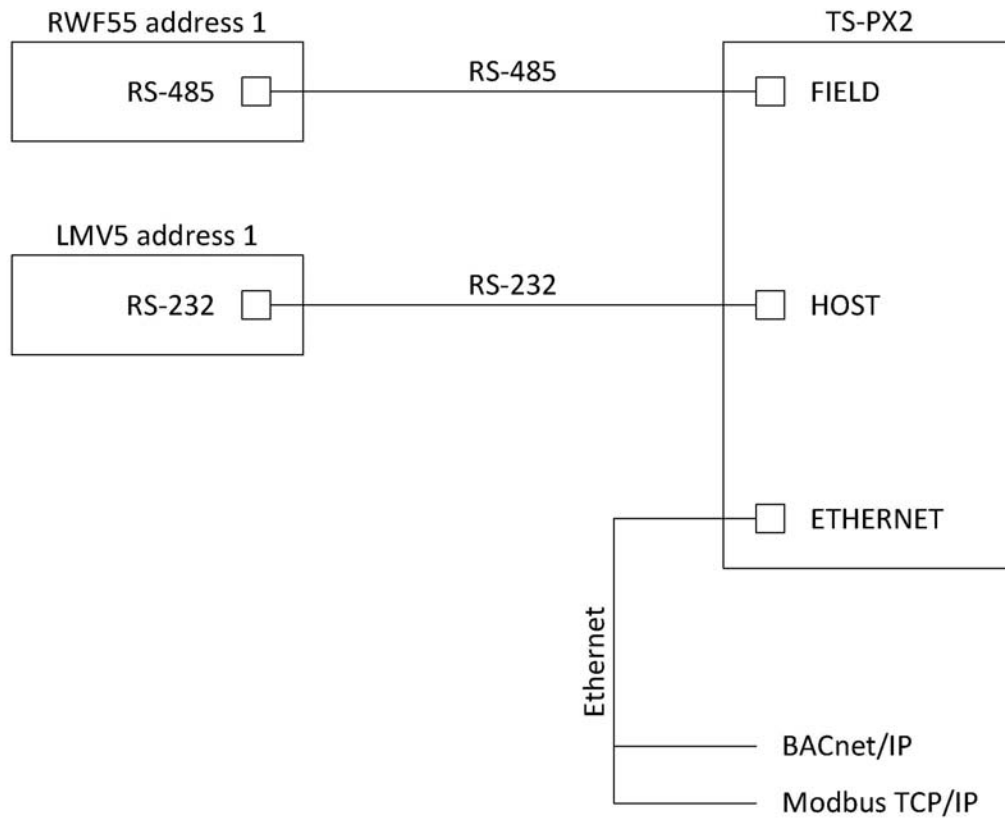

Application Examples (continued)

LMV5 and RWF55 to Any Protocol (using RS-232 to RS-485 converter)

Introduction

The LMV5 has a physical RS-232 connection and the RWF55 has a physical RS-485 connection. To connect both to the same port it is necessary to convert the LMV5 RS-232 medium to RS-485 (see *6x LMV5 to Any Protocol* for additional detail). Choose the TS-PX4 (all protocols except LonWorks) or the TS-PL4 (LonWorks) for this application.

Procedure

1. Set the DIP switches for the selected profile (see *Protocol Selection* for additional detail). This step is not applicable when using the TS-PL4 for LonWorks.
2. Connect the RS-485 converter device and the RWF55 device to the HOST port in a serial daisy-chain (see *Appendix - RS-485 Wiring* for additional detail).
3. Configure the LMV5 for the desired Modbus address (see *Appendix - LMV5 Configuration for Modbus* for additional detail).
4. Configure the RWF55 for the desired Modbus address (see *Appendix - RWF55 Configuration for Modbus* for additional detail).
5. Use the web-based configuration utility to set up the LMV5 HOST-port profile.
6. Use the web-based configuration utility to set up the RWF55 HOST-port profile.
7. Restart the protocol converter.

Application Examples (continued)

BACnet/IP, BACnet MS/TP, Metasys N2 or Modbus TCP/IP Topology

Scalable HOST-port: Yes (quantities and device types can be adjusted)

Scalable FIELD-port: N/A (used for field protocol)

Scalable ETHERNET-port: N/A (used for field protocol)

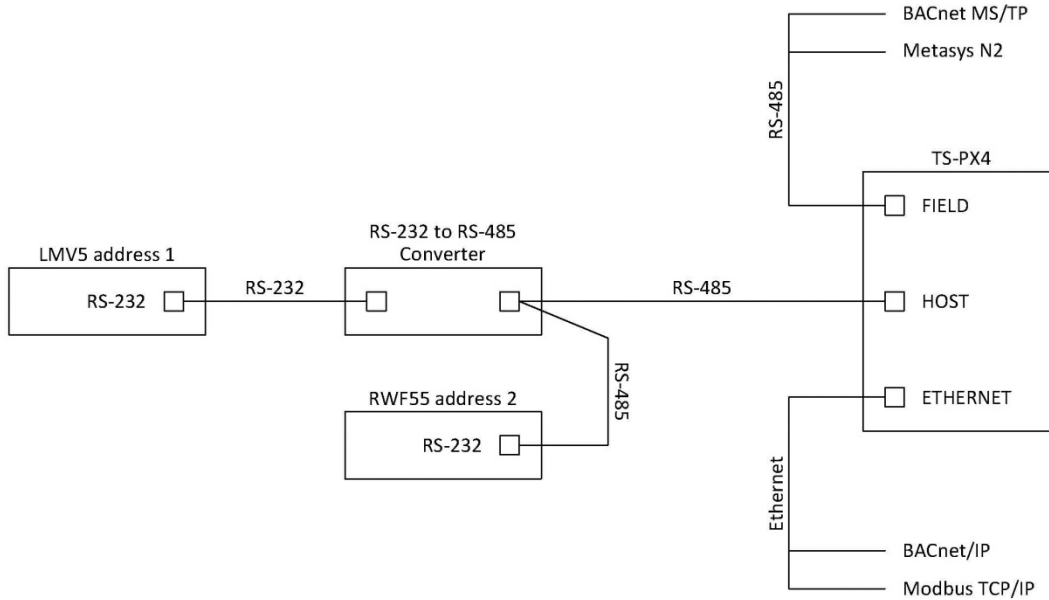

LonWorks Topology

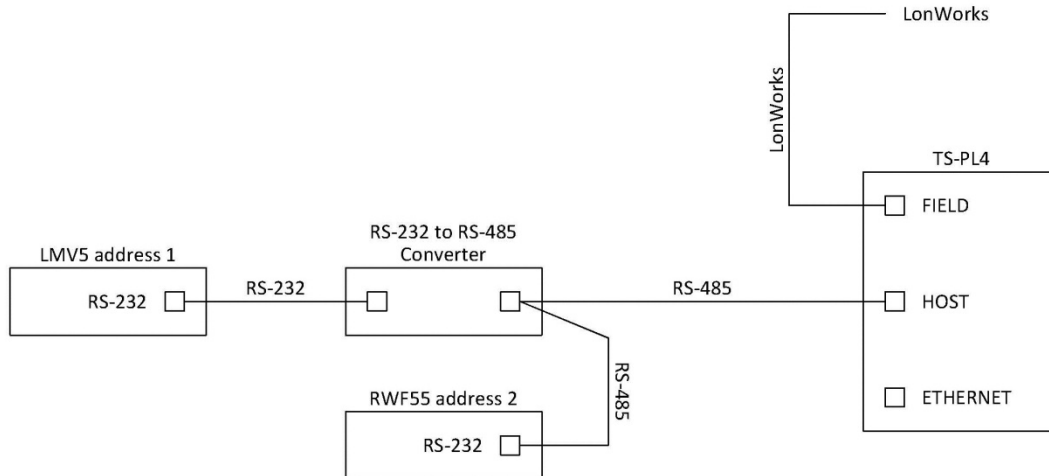

Application Examples (continued)

6x LMV5 to Any Protocol

Introduction

The LMV5 has a physical RS-232 connection. RS-232 is a single-drop medium, which means that only two devices can talk across a network, the client and the server. To be able to connect more than one LMV5 to the protocol converter, the RS-232 medium must first be converted to RS-485 at each unit. A kit is available from SCC (part number K3SC-10-AC100-240) that can accomplish this. Once converted, the LMV5 can be considered an RS-485 device, allowing multiple to be connected to the protocol converter. Choose the TS-PX4 (all protocols except LonWorks) or the TS-PL4 (LonWorks) for this application.

Procedure

1. Set the DIP switches for the selected profile (see *Protocol Selection* for additional detail). This step is not applicable when using the TS-PL4 for LonWorks.
2. Connect the six RS-485 converter devices to the HOST port in a serial daisy-chain (see *Appendix - RS-485 Wiring* for additional detail).
3. Configure the devices for the desired Modbus addresses (see *Appendix - LMV5 Configuration for Modbus* for additional detail). Note that they must be unique.
4. Use the web-based configuration utility to set up six LMV5 HOST-port profiles.
5. Restart the protocol converter.

Application Examples (continued)

BACnet/IP, BACnet MS/TP, Metasys N2 or Modbus TCP/IP Topology

Scalable HOST-port: Yes (quantities and device types can be adjusted)

Scalable FIELD-port: N/A (used for field protocol)

Scalable ETHERNET-port: N/A (used for field protocol)

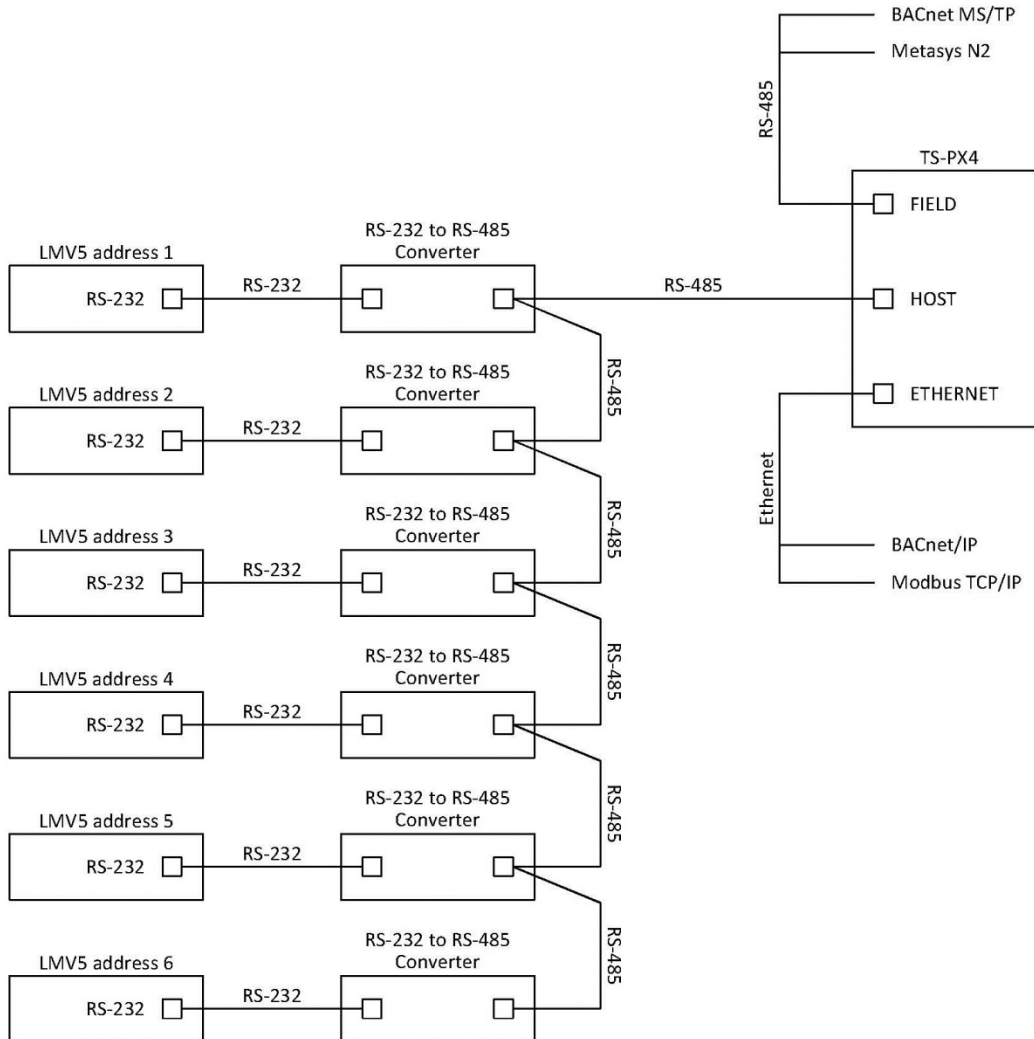

Application Examples (continued)

LonWorks Topology

Scalable HOST-port: Yes (quantities and device types can be adjusted)

Scalable FIELD-port: N/A (used for field protocol)

Scalable ETHERNET-port: N/A (used for field protocol)

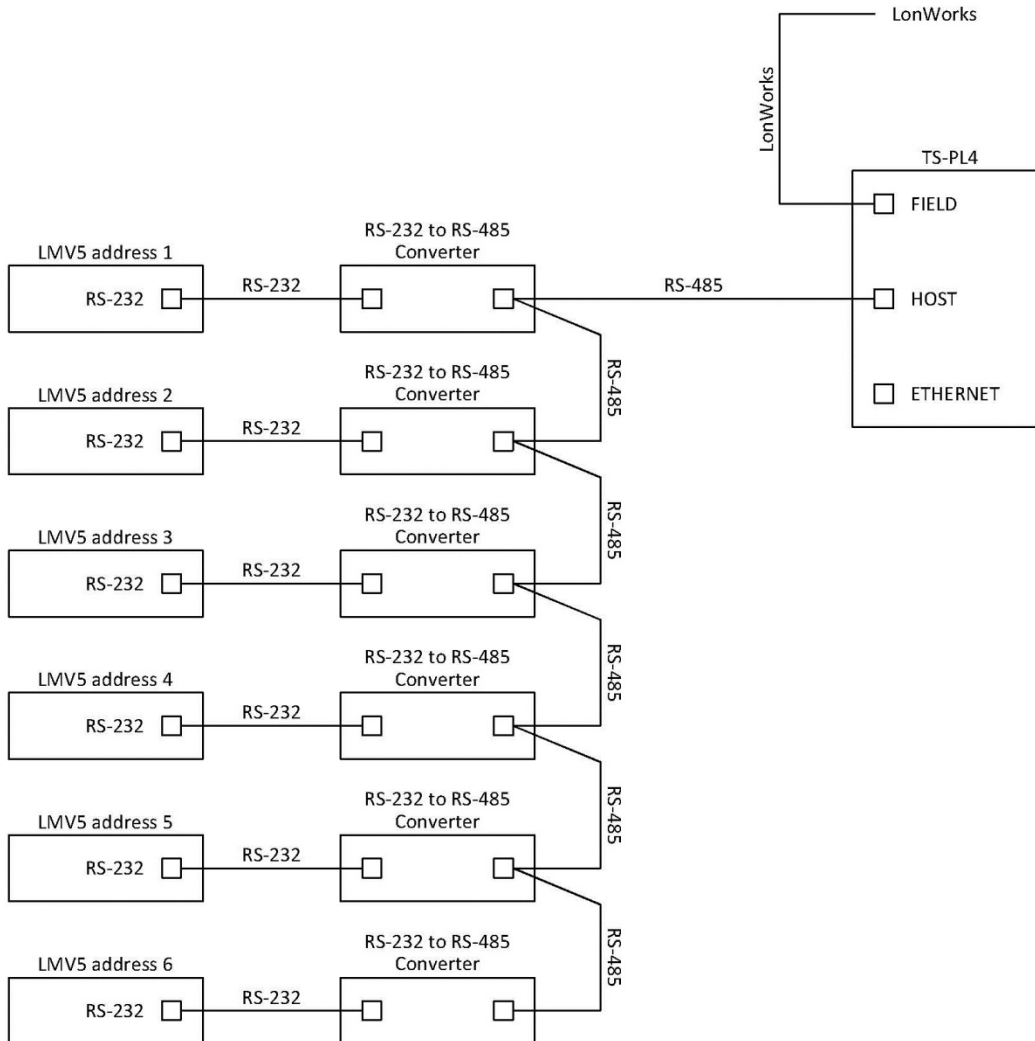

Application Examples (continued)

4x LMV3 and 4x RWF55 to Any Protocol

Introduction

The LMV3 has a physical RS-485 connection (via the OCI412.10) and the RWF55 has a physical RS-485 connection. Choose the TS-PX4 (all protocols except LonWorks) or the TS-PL4 (LonWorks) for this application.

Procedure

1. Set the DIP switches for the selected profile (see *Protocol Selection* for additional detail). This step is not applicable when using the TS-PL4 for LonWorks.
2. Connect the four LMV3 devices and the four RWF55 devices to the HOST port in a serial daisy-chain (see *Appendix - RS-485 Wiring* for additional detail).
3. Configure the devices for the desired Modbus addresses (see *Appendix - LMV3 Configuration for Modbus* and *Appendix - RWF55 Configuration for Modbus* for additional detail). Note that they must be unique.
4. Use the web-based configuration utility to set up four LMV3 HOST-port profiles.
5. Use the web-based configuration utility to set up four RWF55 HOST-port profiles.
6. Restart the protocol converter.

Note that if the selected protocol uses Ethernet (BACnet/IP or Modbus TCP/IP), the devices could be separated so that the four LMV3 devices connect to the HOST port and the four RWF55 devices connect to the FIELD port. Any other combination can also be supported. Simply substitute HOST or FIELD for the other when configuring the profiles.

Application Examples (continued)

BACnet/IP or Modbus TCP/IP Topology

This topology uses the FIELD port for RWF55 devices and the HOST port for LMV3 devices.

Scalable HOST-port: Yes (quantities and device types can be adjusted)

Scalable FIELD-port: Yes (quantities and device types can be adjusted)

Scalable ETHERNET-port: N/A (used for field protocol)

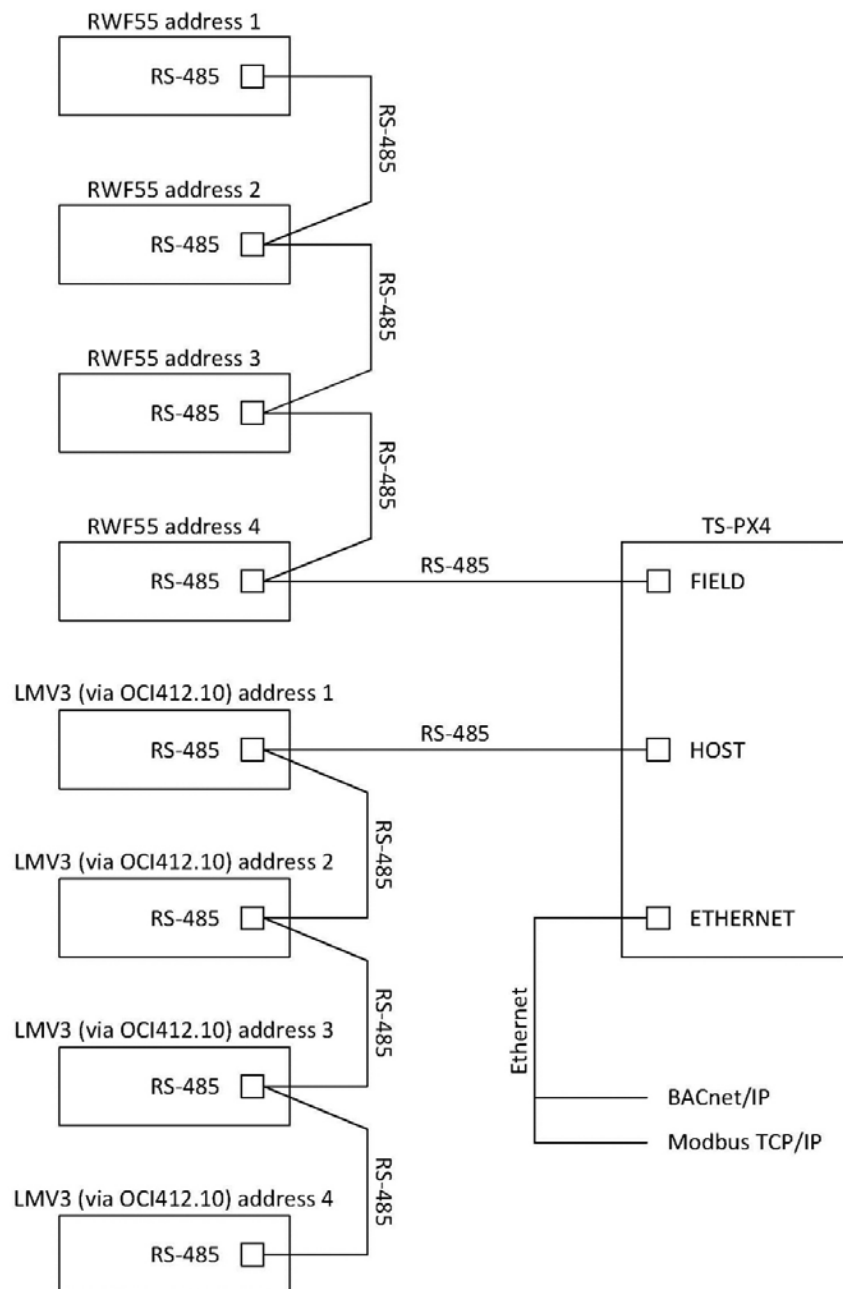

Application Examples (continued)

BACnet/IP, BACnet MS/TP, Metasys N2 or Modbus TCP/IP Topology

This topology uses the HOST port for all devices.

Scalable HOST-port: Yes (quantities and device types can be adjusted)

Scalable FIELD-port: N/A (used for field protocol)

Scalable ETHERNET-port: N/A (used for field protocol)

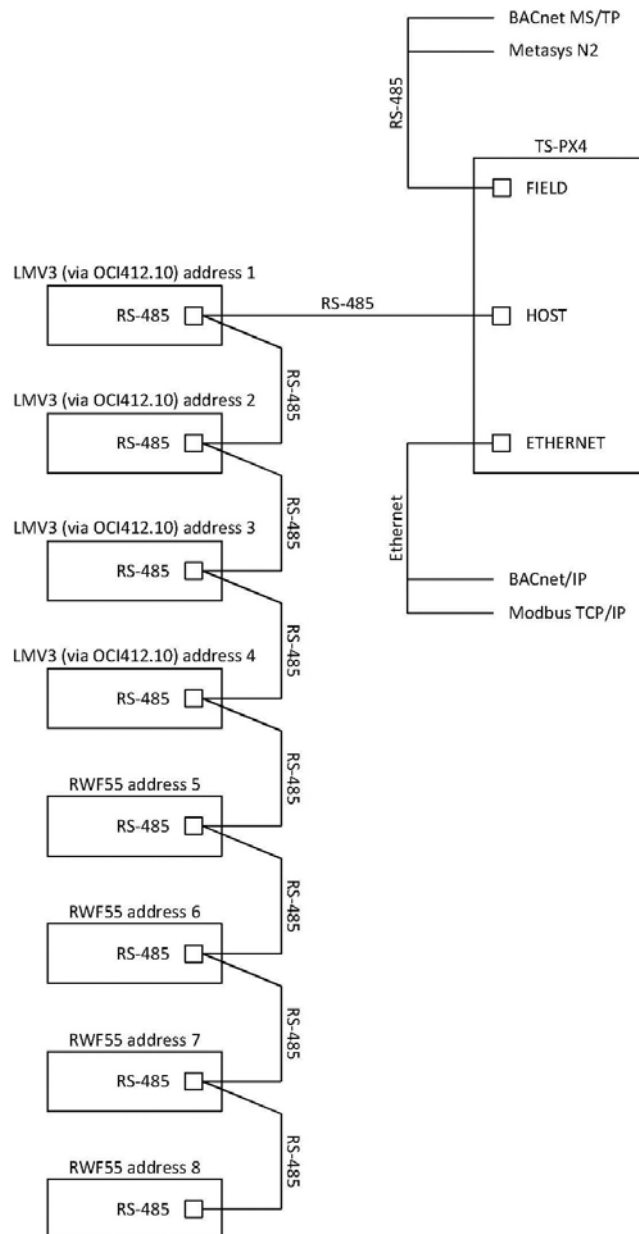

Application Examples (continued)

LonWorks Topology

Scalable HOST-port: Yes (quantities and device types can be adjusted)

Scalable FIELD-port: N/A (used for field protocol)

Scalable ETHERNET-port: N/A (used for field protocol)

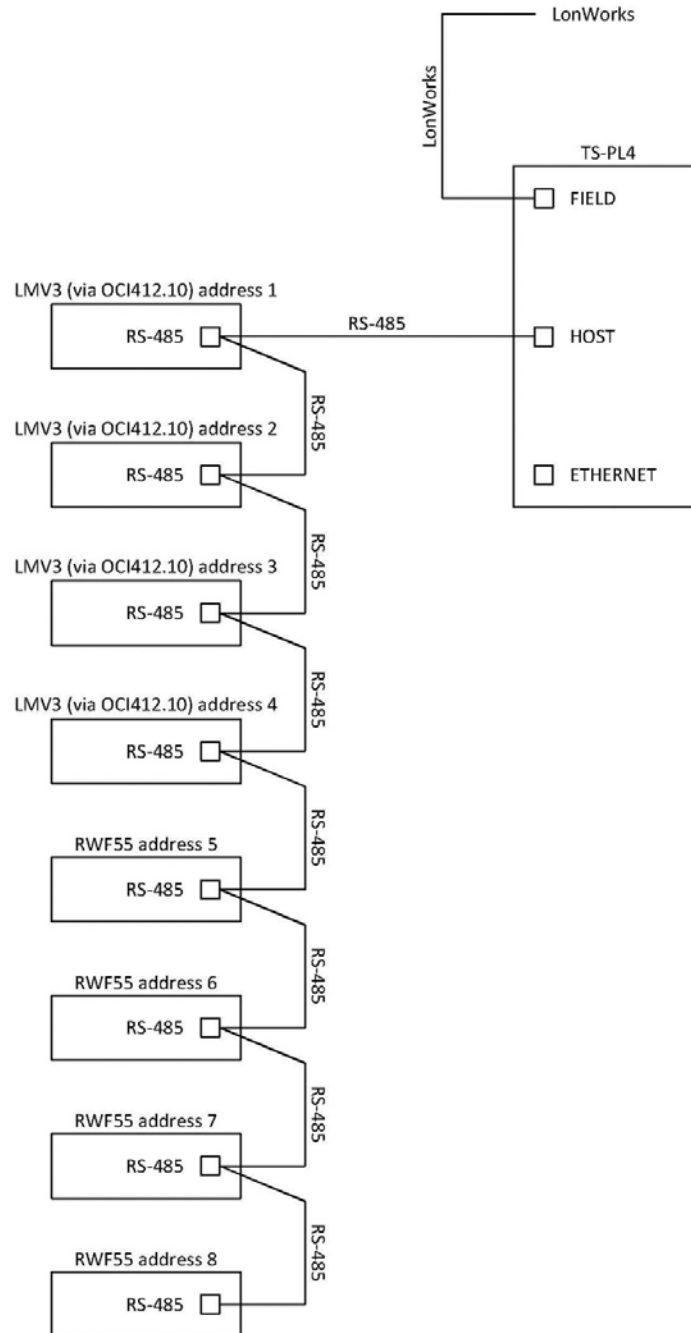

Application Examples (continued)

Total Boiler Room Example: 2x LMV5, 2x RWF55 and TS Series Deaerator/Surge Tank Master to Any Protocol

Introduction

The LMV5 has a physical RS-232 connection and the RWF55 has a physical RS-485 connection. To connect both to the same port it is necessary to convert the LMV5 RS-232 medium to RS-485 (see *6x LMV5 to Any Protocol* for additional detail). The TS Series Deaerator/Surge Tank Master has a physical Ethernet connection. Choose the TS-PX4 (all protocols except LonWorks) or the TS-PL4 (LonWorks) for this application. If an Ethernet protocol (BACnet/IP or Modbus TCP/IP) is required, an Ethernet switch can be provided with the kit for multiple Ethernet connections. A switch is not necessary if only one Ethernet device is going to connect to the Ethernet port.

Procedure

1. Set the DIP switches for the selected profile (see *Protocol Selection* for additional detail). This step is not applicable when using the TS-PL4 for LonWorks.
2. Connect the two RS-485 converter devices and the two RWF55 devices to the HOST port in a serial daisy-chain (see *Appendix - RS-485 Wiring* for additional detail).
3. Connect the TS Series Deaerator/Surge Tank Master to the Ethernet switch (if equipped) or to the ETHERNET port directly.
4. Configure the LMV5 devices for the desired Modbus addresses (see *Appendix - LMV5 Configuration for Modbus* for additional detail). Note that they must be unique.
5. Configure the RWF55 devices for the desired Modbus addresses (see *Appendix - RWF55 Configuration for Modbus* for additional detail). Note that they must be unique.
6. Use the web-based configuration utility to set up two LMV5 HOST-port profiles.
7. Use the web-based configuration utility to set up two RWF55 HOST-port profiles.
8. Use the web-based configuration utility to set up the TS Series Deaerator/Surge Tank Master ETHERNET-port profile.
9. Restart the protocol converter.

Application Examples (continued)

BACnet/IP, BACnet MS/TP, Metasys N2 or Modbus TCP/IP Topology

Scalable HOST-port: Yes (quantities and device types can be adjusted)

Scalable FIELD-port: N/A (used for field protocol)

Scalable ETHERNET-port: Yes (quantities and device types can be adjusted)

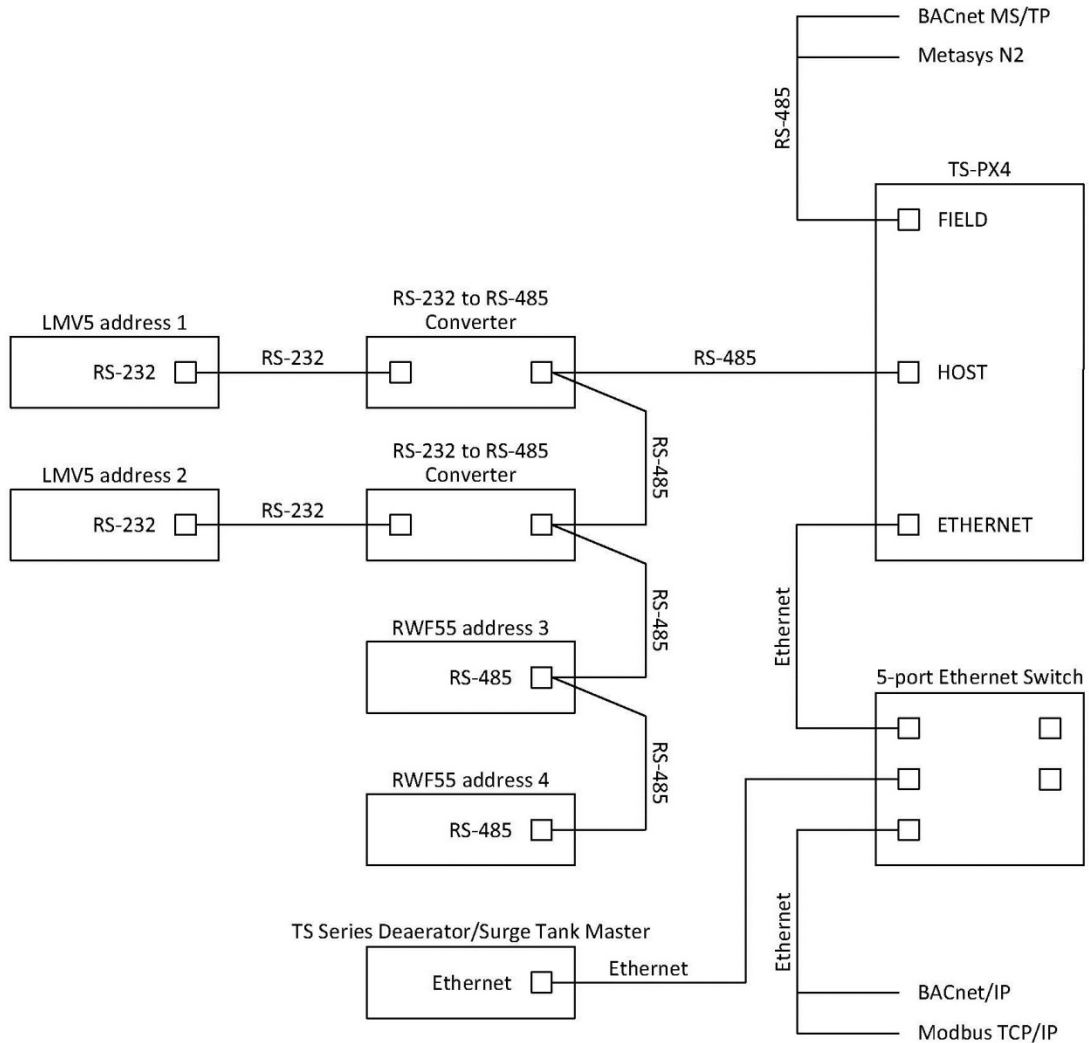

Application Examples (continued)

LonWorks Topology

Scalable HOST-port: Yes (quantities and device types can be adjusted)

Scalable FIELD-port: N/A (used for field protocol)

Scalable ETHERNET-port: Yes (quantities and device types can be adjusted)

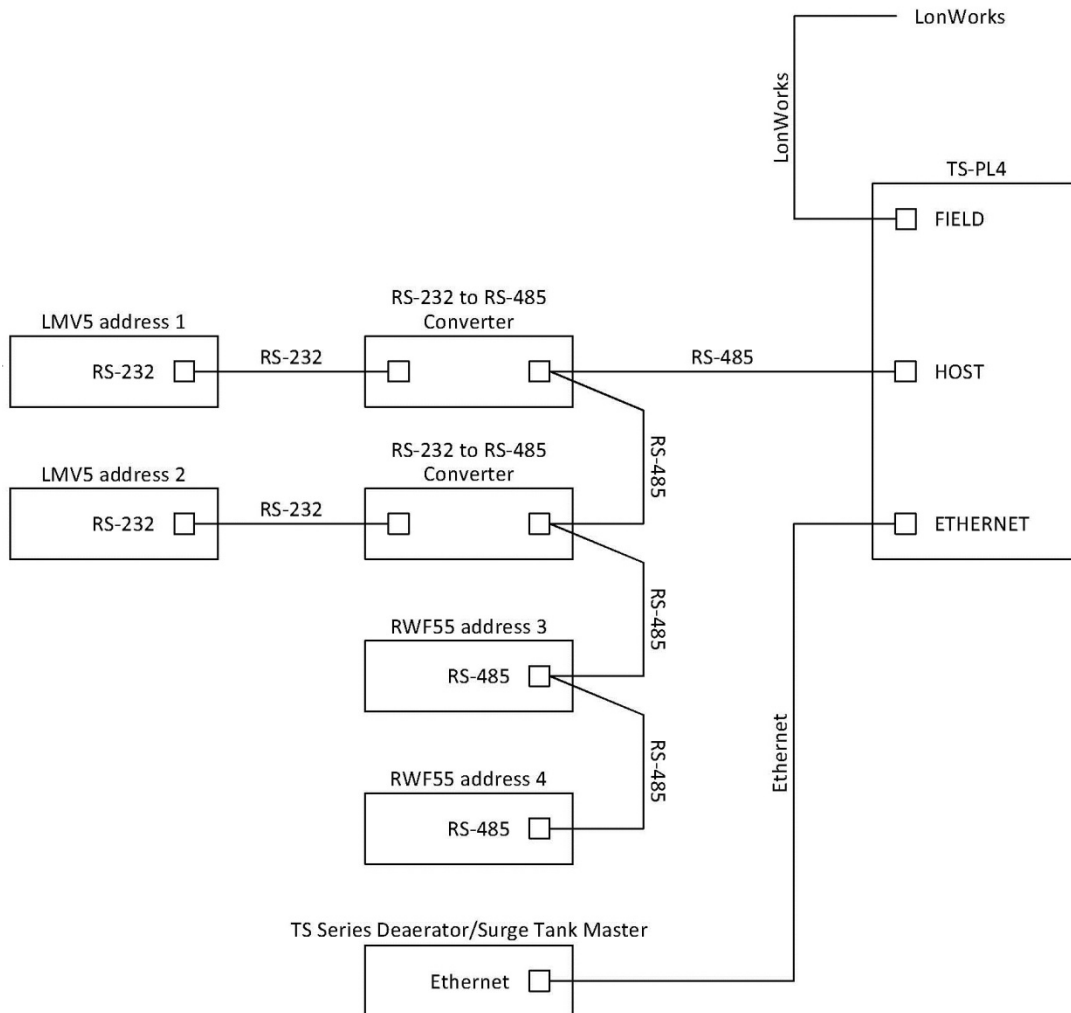

Application Examples (continued)

Total Boiler Room Example: 2x LMV3, 2x RWF10, 2x RWF55 and 2x TS Series Touchscreen Kit to Any Protocol

Introduction

The LMV3 has a physical RS-485 connection (via the OCI412.10) and the RWF55 has a physical RS-485 connection. The TS Series Touchscreen Kit has a physical Ethernet connection. Choose the TS-PX4 (all protocols except LonWorks) or the TS-PL4 (LonWorks) for this application. An Ethernet switch can be provided with the kit for multiple Ethernet connections.

Procedure

1. Set the DIP switches for the selected profile (see *Protocol Selection* for additional detail). This step is not applicable when using the TS-PL4 for LonWorks.
2. Connect the two LMV3 devices, the two RWF10 devices and the two RWF55 devices to the HOST port in a serial daisy-chain (see *Appendix - RS-485 Wiring* for additional detail).
3. Connect each TS Series Touchscreen Kit to the Ethernet switch (if equipped) or to the external Ethernet switch. If the TS Series Touchscreen Kits are optioned with Expanded Annunciation, the integrated Ethernet switch in each device can be wired in series to form a network in lieu of a consolidated Ethernet switch.
4. Configure the LMV3 devices for the desired Modbus addresses (see *Appendix - LMV3 Configuration for Modbus* for additional detail). Note that they must be unique.
5. Configure the RWF10 devices for the desired Modbus addresses (see *Appendix - RWF10 Configuration for Modbus* for additional detail). Note that they must be unique.
6. Configure the RWF55 devices for the desired Modbus addresses (see *Appendix - RWF55 Configuration for Modbus* for additional detail). Note that they must be unique.
7. Use the web-based configuration utility to set up two LMV3 HOST-port profiles.
8. Use the web-based configuration utility to set up two RWF10 HOST-port profiles.
9. Use the web-based configuration utility to set up two RWF55 HOST-port profiles.
10. Use the web-based configuration utility to set up two TS Series Touchscreen Kit ETHERNET-port profiles.
11. Restart the protocol converter.

Application Examples (continued)

BACnet/IP, BACnet MS/TP, Metasys N2 or Modbus TCP/IP Topology

Scalable HOST-port: Yes (quantities and device types can be adjusted)

Scalable FIELD-port: N/A (used for field protocol)

Scalable ETHERNET-port: Yes (quantities and device types can be adjusted)

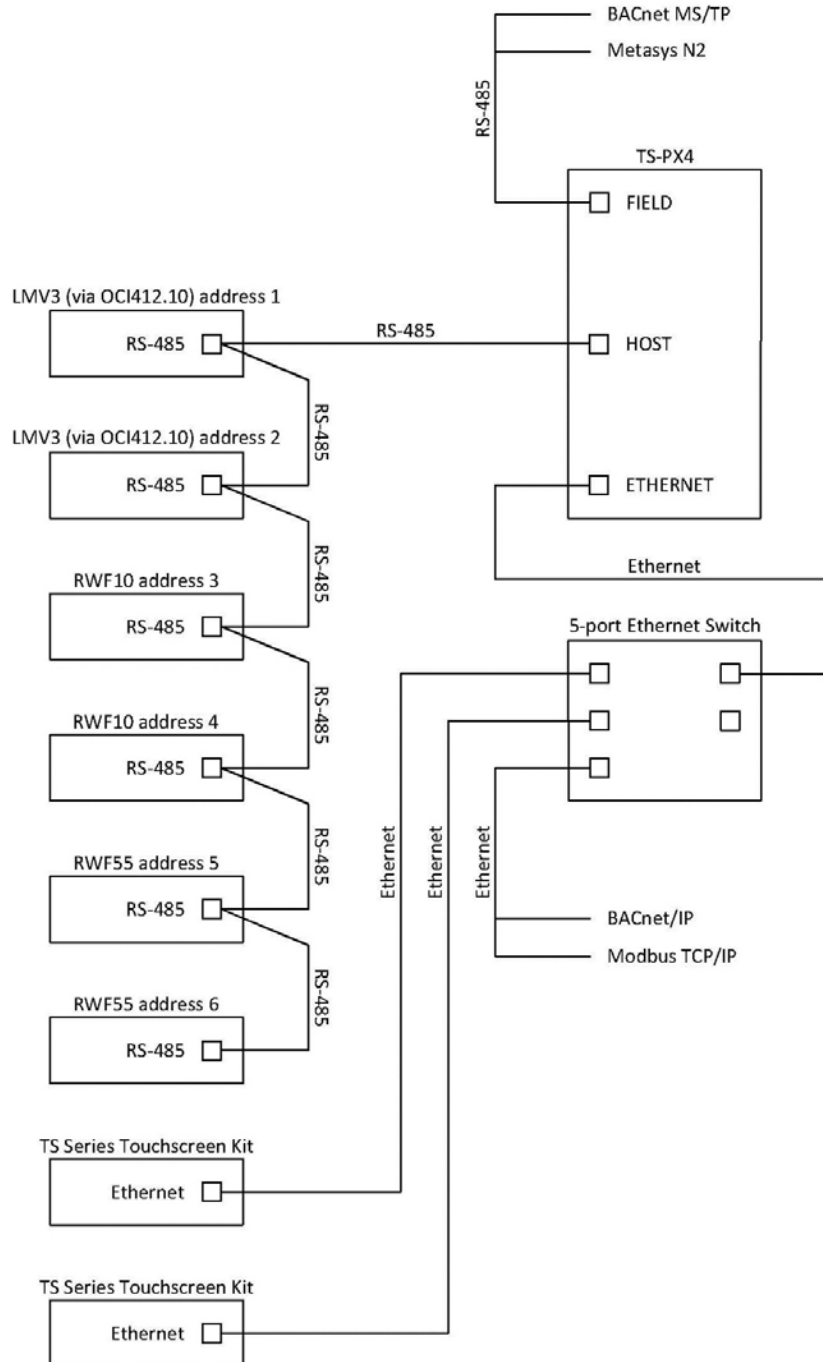

Application Examples (continued)

LonWorks Topology

Scalable HOST-port: Yes (quantities and device types can be adjusted)

Scalable FIELD-port: N/A (used for field protocol)

Scalable ETHERNET-port: Yes (quantities and device types can be adjusted)

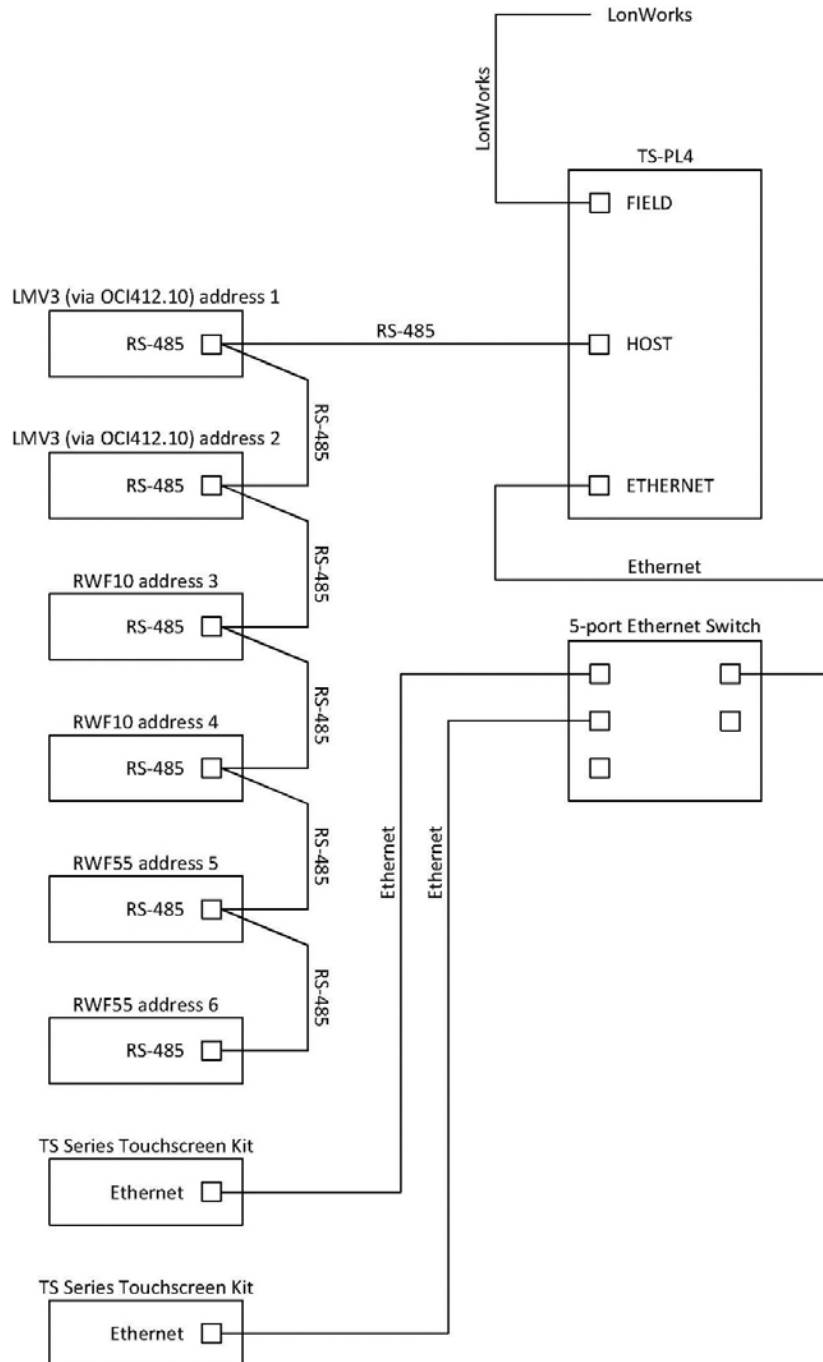

Application Examples (continued)

Total Boiler Room Example: TS Series Lead/Lag Master to Any Protocol

Introduction

The TS Series Lead/Lag Master has a physical Ethernet connection. Choose the TS-PX2/TS-PX4 (all protocols except LonWorks) or the TS-PL2/TS-PL4 (LonWorks) for this application. An Ethernet switch can be provided with the kit for multiple Ethernet connections.

Procedure

1. Set the DIP switches for the selected profile (see *Protocol Selection* for additional detail). This step is not applicable when using the TS-PL4 for LonWorks.
2. Connect the TS Series Lead/Lag Master to the Ethernet switch (if equipped) or to the external Ethernet switch.
3. Use the web-based configuration utility to set up the TS Series Lead/Lag Master HOST-port profile, indicating the quantity of boilers connected (see *Appendix - TS Series Configuration* for additional detail).
4. Restart the protocol converter.

Application Examples (continued)

BACnet/IP, BACnet MS/TP, Metasys N2 or Modbus TCP/IP Topology

Scalable HOST-port: Yes (quantities and device types can be adjusted)

Scalable FIELD-port: N/A (used for field protocol)

Scalable ETHERNET-port: N/A (used for field protocol)

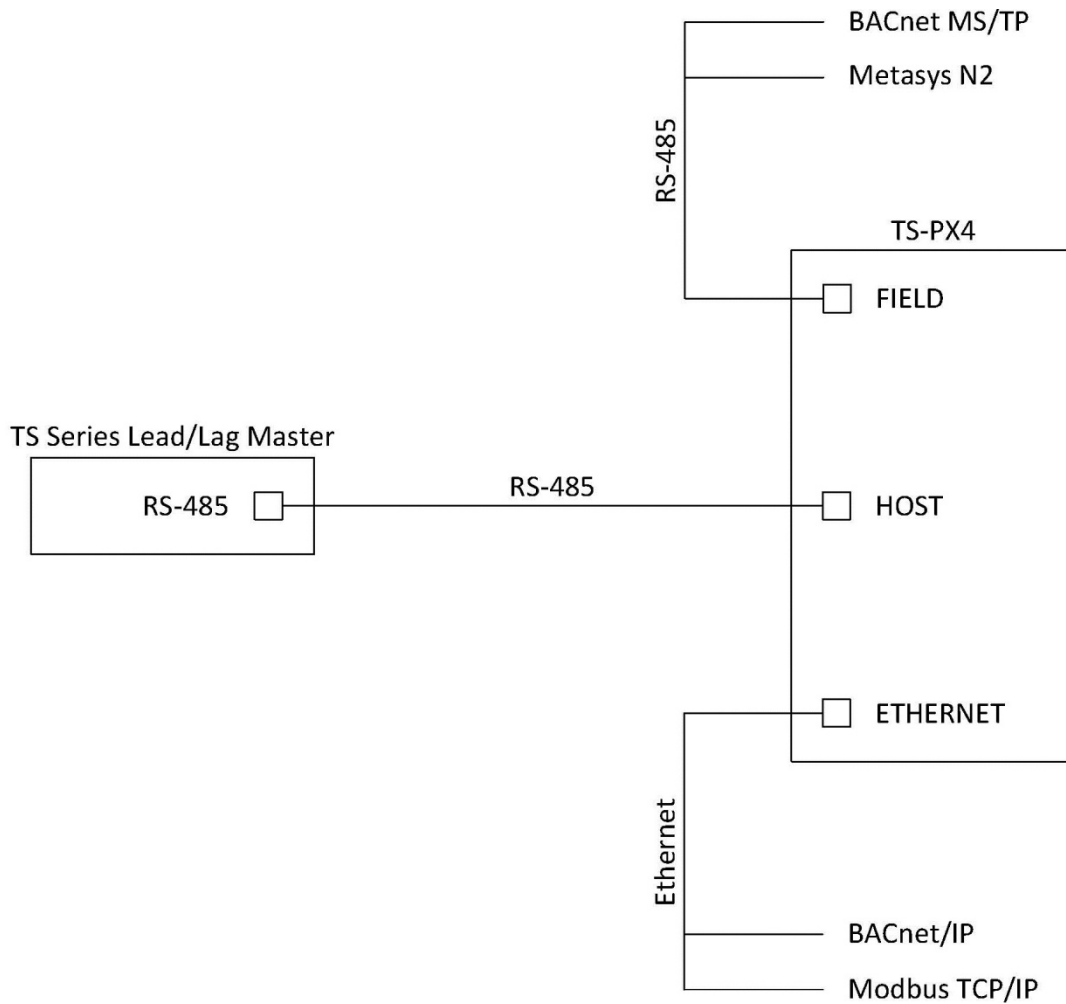

Application Examples (continued)

LonWorks Topology

Scalable HOST-port: Yes (quantities and device types can be adjusted)

Scalable FIELD-port: N/A (used for field protocol)

Scalable ETHERNET-port: N/A (used for field protocol)

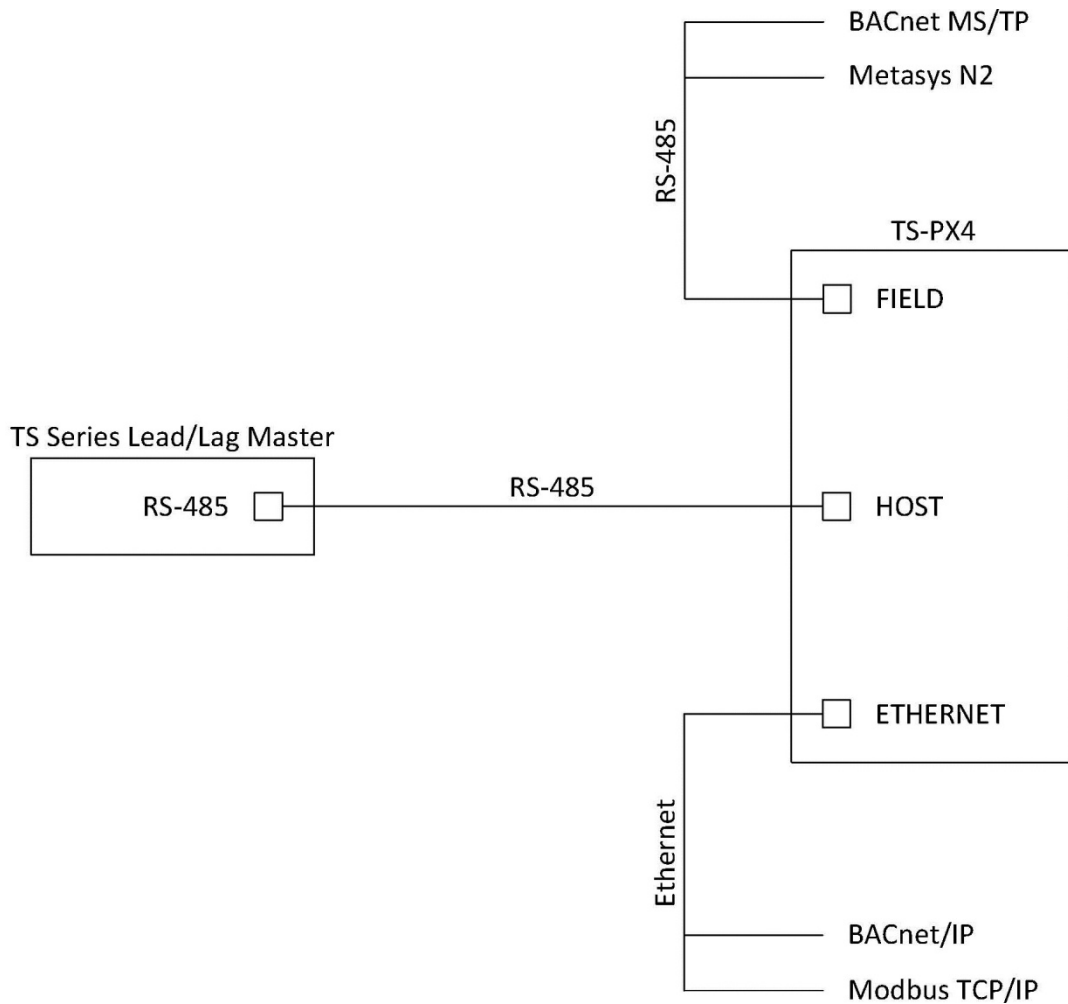

Application Examples (continued)

Total Boiler Room Example: TS Series Lead/Lag Master and 2x TS Series Touchscreen Kit to Any Protocol

Introduction

The TS Series Lead/Lag Master and the TS Series Touchscreen Kit each have a physical Ethernet connection. Choose the TS-PX2/TS-PX4 (all protocols except LonWorks) or the TS-PL2/TS-PL4 (LonWorks) for this application. An Ethernet switch can be provided with the kit for multiple Ethernet connections.

Procedure

1. Set the DIP switches for the selected profile (see *Protocol Selection* for additional detail). This step is not applicable when using the TS-PL4 for LonWorks.
2. Connect the TS Series Lead/Lag Master to the Ethernet switch (if equipped) or to the external Ethernet switch.
3. Connect each TS Series Touchscreen Kit to the Ethernet switch (if equipped) or to the external Ethernet switch. If the TS Series Touchscreen Kits are optioned with Expanded Annunciation, the integrated Ethernet switch in each device can be wired in series to form a network in lieu of a consolidated Ethernet switch.
4. Use the web-based configuration utility to set up the TS Series Lead/Lag Master ETHERNET-port profile, indicating the quantity of boilers connected (see *Appendix - TS Series Configuration* for additional detail).
5. Use the web-based configuration utility to set up two TS Series Touchscreen Kit ETHERNET-port profiles.
6. Restart the protocol converter.

Application Examples (continued)

BACnet/IP, BACnet MS/TP, Metasys N2 or Modbus TCP/IP Topology

Scalable HOST-port: Yes (quantities and device types can be adjusted)

Scalable FIELD-port: N/A (used for field protocol)

Scalable ETHERNET-port: Yes (quantities and device types can be adjusted)

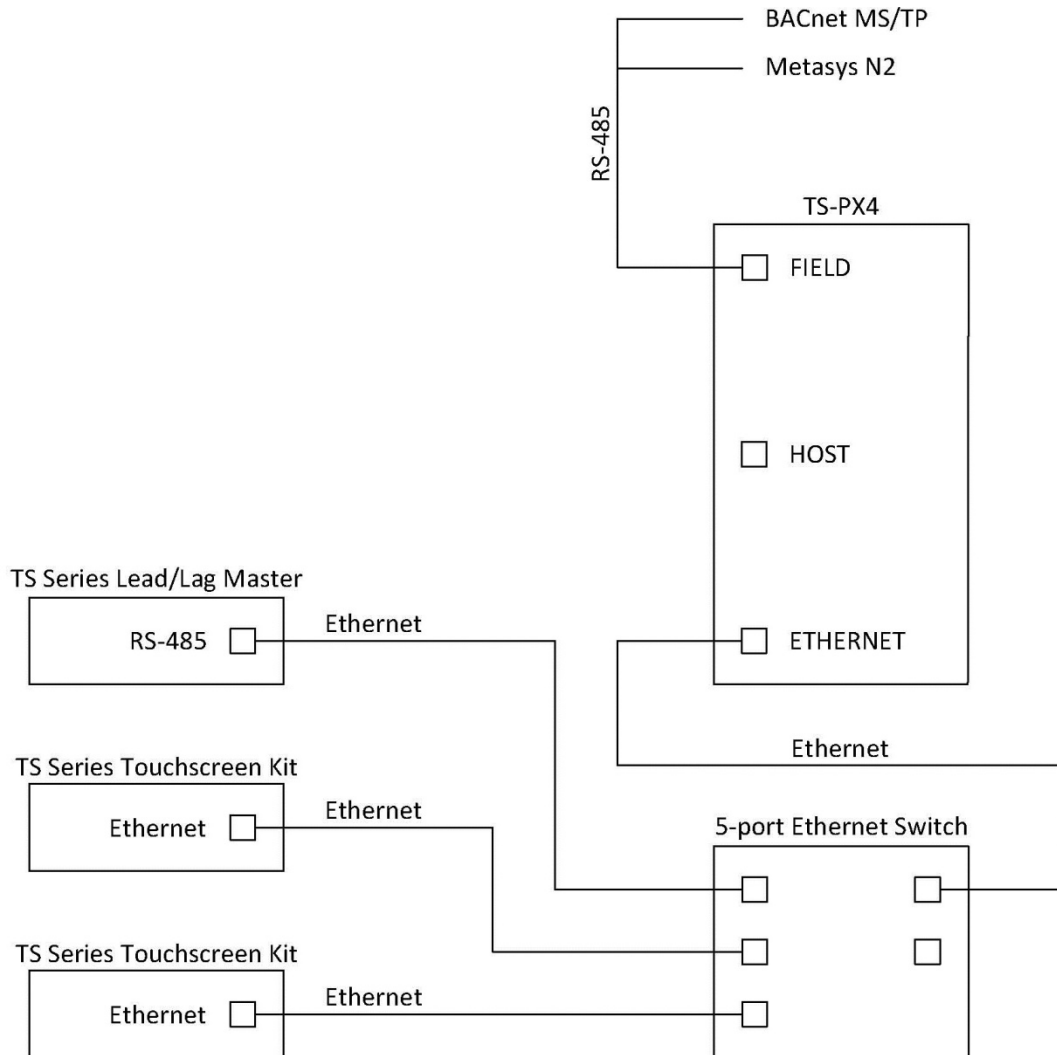

Application Examples (continued)

LonWorks Topology

Scalable HOST-port: Yes (quantities and device types can be adjusted)

Scalable FIELD-port: N/A (used for field protocol)

Scalable ETHERNET-port: Yes (quantities and device types can be adjusted)

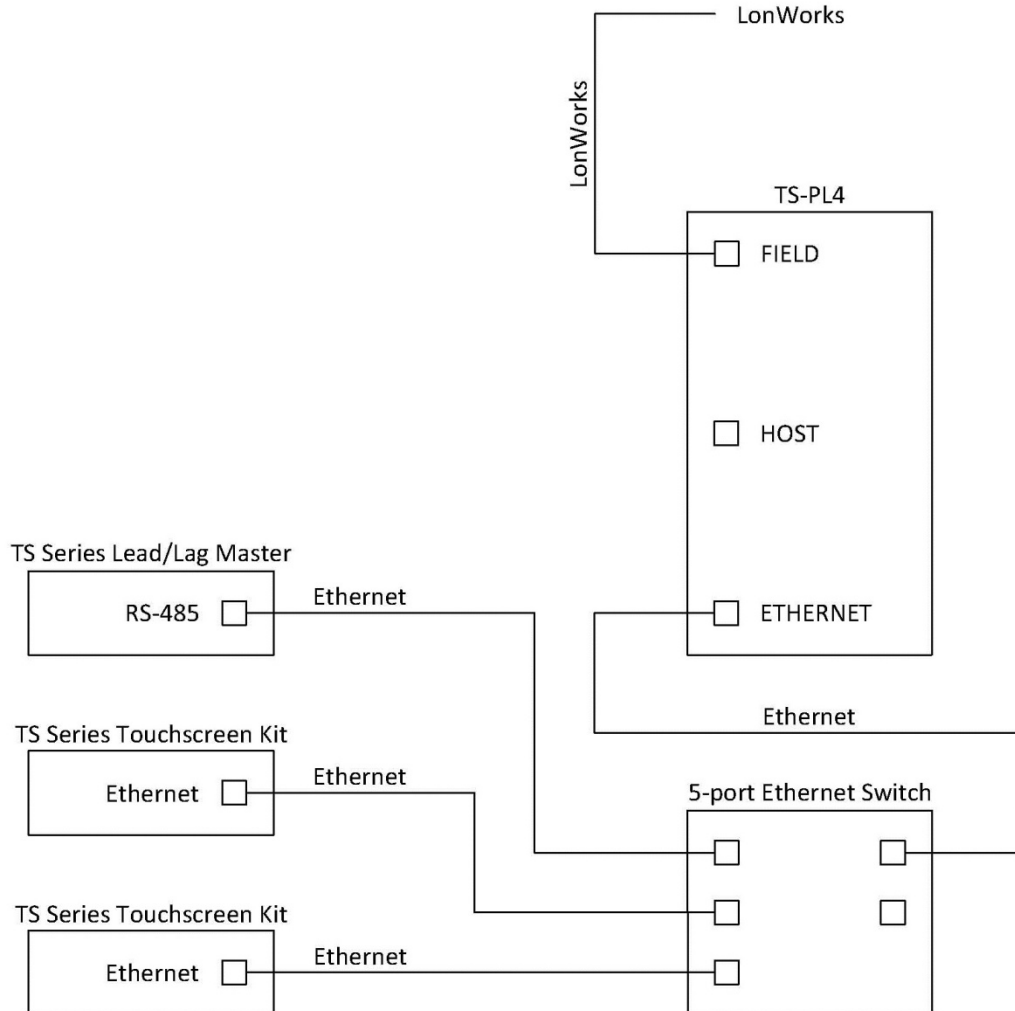

Point List BACnet and Metasys N2 - LMV3

Point Name	BACnet Obj Type	BACnet Obj ID	N2 Data Type	N2 Address
LMV PHASE	AI	1	AI	1
LMV FUEL ACTUATOR	AI	2	AI	2
LMV AIR ACTUATOR	AI	3	AI	3
LMV VSD OUTPUT	AI	4	AI	4
LMV CURRENT FUEL	AI	5	AI	5
LMV CURRENT OUTPUT	AI	6	AI	6
LMV FLAME SIGNAL	AI	7	AI	7
LMV FUEL THROUGHPUT	AI	8	AI	8
LMV STARTUP COUNTER	AI	9	AI	9
LMV CURRENT ERROR CODE	AI	10	AI	10
LMV CURRENT DIAGNOSTIC CODE	AI	11	AI	11
LMV CURRENT ERROR CLASS	AI	12	AI	12
LMV CURRENT ERROR PHASE	AI	13	AI	13
LMV INPUT WORD	AI	14	AI	14
LMV OUTPUT WORD	AI	15	AI	15
LMV PROGRAM STOP	AV	16	AO	16
LMV MODBUS LOCAL/REMOTE	AV	17	AO	17
LMV MODBUS WATCHDOG	AV	18	AO	18
LMV MODBUS OPERATING MODE	AV	19	AO	19
LMV MODBUS OUTPUT	AV	20	AO	20
LMV HOURS RUN FUEL 0 RESET	AV	21	AO	21
LMV HOURS RUN FUEL 1 RESET	AV	22	AO	22
LMV HOURS CONNECT TO POWER	AI	23	AI	23
LMV STARTUPS FUEL 0 RESET	AV	24	AO	24
LMV STARTUPS FUEL 1 RESET	AV	25	AO	25
LMV STARTUPS TOTAL FIXED	AI	26	AI	26
LMV TOTAL VOLUME FUEL0	AV	27	AO	27
LMV TOTAL VOLUME FUEL1	AV	28	AO	28
LMV NUMBER OF LOCKOUTS	AI	29	AI	29
LMV PRESELECT OUTPUT FUEL 0	AV	30	AO	30
LMV PRESELECT OUTPUT FUEL 1	AV	31	AO	31
LMV BC PARAMETER SET CODE	AI	32	AI	32
LMV BC PARAMETER SET VER	AI	33	AI	33
LMV BC ID DATE YEAR 2-DIGIT	AI	34	AI	34
LMV BC ID DATE MONTH	AI	35	AI	35
LMV BURNER CNTRL ID DATE DAY	AI	36	AI	36
LMV BURNER CONTROL ID NUM	AI	37	AI	37
LMV SW VER BURNER CONTROL	AI	38	AI	38
LMV MINIMUM OUTPUT FUEL 0	AI	39	AI	39
LMV MAXIMUM OUTPUT FUEL 0	AI	40	AI	40
LMV MINIMUM OUTPUT FUEL 1	AI	41	AI	41
LMV MAXIMUM OUTPUT FUEL 1	AI	42	AI	42
LMV ERROR ERR CODE CURRENT	AI	43	AI	43
LMV ERROR DIAG CODE CURRENT	AI	44	AI	44
LMV ERROR ERR CLASS CURRENT	AI	45	AI	45

Point List BACnet and Metasys N2 - LMV3 (continued)

Point Name	BACnet Obj Type	BACnet Obj ID	N2 Data Type	N2 Address
LMV ERROR ERR PHASE CURRENT	AI	46	AI	46
LMV ERROR FUEL CURRENT	AI	47	AI	47
LMV ERROR OUTPUT CURRENT	AI	48	AI	48
LMV ERROR STARTUPS CURRENT	AI	49	AI	49
LMV CONTROLLER SWITCH	BI	1	DI	1
LMV VALVE PROVING SW	BI	2	DI	2
LMV SAFETY LOOP	BI	3	DI	3
LMV GAS PRESS SW MIN	BI	4	DI	4
LMV GAS PRESS SW MAX	BI	5	DI	5
LMV AIR PRESSURE SW	BI	6	DI	6
LMV ALARM	BI	7	DI	7
LMV IGNITION	BI	8	DI	8
LMV FAN OUTPUT	BI	9	DI	9
LMV FUEL VALVE V1	BI	10	DI	10
LMV FUEL VALVE V2	BI	11	DI	11
LMV FUEL VALVE V3/PV	BI	12	DI	12

Point List LonWorks - LMV3

Point Name	LonWorks Input	LonWorks Output
LMV PHASE	not writable	nvo(node)LmvPhase
LMV FUEL ACTUATOR	not writable	nvo(node)LmvFuelActuator
LMV AIR ACTUATOR	not writable	nvo(node)LmvAirActuator
LMV VSD OUTPUT	not writable	nvo(node)LmvVsdOutput
LMV CURRENT FUEL	not writable	nvo(node)LmvCurrentFuel
LMV CURRENT OUTPUT	not writable	nvo(node)LmvCurrentOutput
LMV FLAME SIGNAL	not writable	nvo(node)LmvFlameSignal
LMV FUEL THROUGHPUT	not writable	nvo(node)LmvFuelThroughput
LMV STARTUP COUNTER	not writable	nvo(node)LmvStartupCounter
LMV CURRENT ERROR CODE	not writable	nvo(node)LmvCurrErrorCode
LMV CURRENT DIAGNOSTIC CODE	not writable	nvo(node)LmvCurrDiagCode
LMV CURRENT ERROR CLASS	not writable	nvo(node)LmvCurrErrorClass
LMV CURRENT ERROR PHASE	not writable	nvo(node)LmvCurrtErrorPhase
LMV INPUT WORD	not writable	nvo(node)LmvInputWord
LMV OUTPUT WORD	not writable	nvo(node)LmvOutputWord
LMV PROGRAM STOP	nvi(node)LmvProgramStop	nvo(node)LmvProgramStop
LMV MODBUS LOCAL/REMOTE	nvi(node)LmvModbusLocRem	nvo(node)LmvModbusLocRem
LMV MODBUS WATCHDOG	nvi(node)LmvModbusWatchdog	nvo(node)LmvModbusWatchdog
LMV MODBUS OPERATING MODE	nvi(node)LmvModbusOpMode	nvo(node)LmvModbusOpMode
LMV MODBUS OUTPUT	nvi(node)LmvModbusOutput	nvo(node)LmvModbusOutput
LMV HOURS RUN FUEL 0 RESET	nvi(node)LmvHoursRunFuel0Rst	nvo(node)LmvHoursRunFuel0Rst
LMV HOURS RUN FUEL 1 RESET	nvi(node)LmvHoursRunFuel1Rst	nvo(node)LmvHoursRunFuel1Rst
LMV HOURS CONNECT TO POWER	not writable	nvo(node)LmvHrsConnToPower
LMV STARTUPS FUEL 0 RESET	nvi(node)LmvStartupsFuel0Rst	nvo(node)LmvStartupsFuel0Rst
LMV STARTUPS FUEL 1 RESET	nvi(node)LmvStartupsFuel1Rst	nvo(node)LmvStartupsFuel1Rst
LMV STARTUPS TOTAL FIXED	not writable	nvo(node)LmvStartupsTotFixed
LMV TOTAL VOLUME FUEL0	nvi(node)LmvTotalVolumeFuel0	nvo(node)LmvTotalVolumeFuel0
LMV TOTAL VOLUME FUEL1	nvi(node)LmvTotalVolumeFuel1	nvo(node)LmvTotalVolumeFuel1
LMV NUMBER OF LOCKOUTS	not writable	nvo(node)LmvNumOfLockouts
LMV PRESELECT OUTPUT FUEL 0	nvi(node)LmvPreOutputFuel0	nvo(node)LmvPreOutputFuel0
LMV PRESELECT OUTPUT FUEL 1	nvi(node)LmvPreOutputFuel1	nvo(node)LmvPreOutputFuel1
LMV BC PARAMETER SET CODE	not writable	nvo(node)LmvBcParamSetCode
LMV BC PARAMETER SET VER	not writable	nvo(node)LmvBcParamSetVer
LMV BC ID DATE YEAR 2-DIGIT	not writable	nvo(node)LmvBcIdDateYear2
LMV BC ID DATE MONTH	not writable	" "
LMV BURNER CNTRL ID DATE DAY	not writable	" "
LMV BURNER CONTROL ID NUM	not writable	nvo(node)LmvBurnerCntlIdNum
LMV SW VER BURNER CONTROL	not writable	nvo(node)LmvSwVerBurnerCntl
LMV MINIMUM OUTPUT FUEL 0	not writable	nvo(node)LmvMinOutputFuel0
LMV MAXIMUM OUTPUT FUEL 0	not writable	nvo(node)LmvMaxOutputFuel0
LMV MINIMUM OUTPUT FUEL 1	not writable	nvo(node)LmvMinOutputFuel1
LMV MAXIMUM OUTPUT FUEL 1	not writable	nvo(node)LmvMaxOutputFuel1
LMV ERROR ERR CODE CURRENT	not writable	nvo(node)LmvErrErrCodeCurr
LMV ERROR DIAG CODE CURRENT	not writable	nvo(node)LmvErrDiagCodeCurr
LMV ERROR ERR CLASS CURRENT	not writable	nvo(node)LmvErrErrClassCurr

Point List LonWorks - LMV3 (continued)

Point Name	LonWorks Input	LonWorks Output
LMV ERROR ERR PHASE CURRENT	not writable	nvo(node)LmvErrErrPhaseCurr
LMV ERROR FUEL CURRENT	not writable	nvo(node)LmvErrFuelCurr
LMV ERROR OUTPUT CURRENT	not writable	nvo(node)LmvErrOutputCurr
LMV ERROR STARTUPS CURRENT	not writable	nvo(node)LmvErrStartupsCurr
LMV CONTROLLER SWITCH	BI	nvo(node)LmvControllerSwitch
LMV VALVE PROVING SW	BI	nvo(node)LmvValveProvingSw
LMV SAFETY LOOP	BI	nvo(node)LmvSafetyLoop
LMV GAS PRESS SW MIN	BI	nvo(node)LmvGasPressSwMin
LMV GAS PRESS SW MAX	BI	nvo(node)LmvGasPressSwMax
LMV AIR PRESSURE SW	BI	nvo(node)LmvAirPressureSw
LMV ALARM	BI	nvo(node)LmvAlarm
LMV IGNITION	BI	nvo(node)LmvIgnition
LMV FAN OUTPUT	BI	nvo(node)LmvFanOutput
LMV FUEL VALVE V1	BI	nvo(node)LmvFuelValveV1
LMV FUEL VALVE V2	BI	nvo(node)LmvFuelValveV2
LMV FUEL VALVE V3/PV	BI	nvo(node)LmvFuelValveV3Pv

(node) = Modbus address. Example: Point for device with Modbus address 1 would be nvo1xxx.

Point List BACnet and Metasys N2 - LMV5

Point Name	BACnet Obj Type	BACnet Obj ID	N2 Data Type	N2 Point Address
LMV PHASE	AI	1	AI	1
LMV FUEL ACTUATOR	AI	2	AI	2
LMV GAS ACTUATOR	AI	3	AI	3
LMV OIL ACTUATOR	AI	4	AI	4
LMV AIR ACTUATOR	AI	5	AI	5
LMV AUX1 ACTUATOR	AI	6	AI	6
LMV AUX2 ACTUATOR	AI	7	AI	7
LMV AUX3 ACTUATOR	AI	8	AI	8
LMV VSD OUTPUT	AI	9	AI	9
LMV CURRENT FUEL	AI	10	AI	10
LMV CURRENT OUTPUT	AI	11	AI	11
LMV CURRENT SETPOINT	AI	12	AI	12
LMV ACTUAL VALUE	AI	13	AI	13
LMV FLAME SIGNAL	AI	14	AI	14
LMV FUEL THROUGHPUT	AI	15	AI	15
LMV CURRENT O ₂	AI	16	AI	16
LMV GAS UNIT	AI	17	AI	17
LMV OIL UNIT	AI	18	AI	18
LMV TEMPERATURE UNIT	AI	19	AI	19
LMV PRESSURE UNIT	AI	20	AI	20
LMV SENSOR SELECTION	AI	21	AI	21
LMV STARTUP COUNTER	AI	22	AI	22
LMV HOUR COUNTER	AI	23	AI	23
LMV CURRENT ERROR CODE	AI	24	AI	24
LMV CURRENT DIAGNOSTIC CODE	AI	25	AI	25
LMV CURRENT ERROR CLASS	AI	26	AI	26
LMV CURRENT ERROR PHASE	AI	27	AI	27
LMV TEMP LIMIT OFF THRESHOLD	AI	28	AI	28
LMV SUPPLY AIR TEMPERATURE	AI	29	AI	29
LMV FLUE GAS TEMPERATURE	AI	30	AI	30
LMV COMBUSTION EFFICIENCY	AI	31	AI	31
LMV INPUT WORD	AI	32	AI	32
LMV OUTPUT WORD	AI	33	AI	33
LMV PROGRAM STOP	AV	34	AO	34
LMV LOAD CONTROL MODE	AV	35	AO	35
LMV MANUAL/AUTOMATIC	AI	36	AI	36
LMV MODBUS LOCAL/REMOTE	AV	37	AO	37
LMV MODBUS WATCHDOG	AV	38	AO	38
LMV MODBUS OPERATING MODE	AV	39	AO	39
LMV MODBUS SETPOINT W3	AV	40	AO	40
LMV MODBUS OUTPUT	AV	41	AO	41
LMV MODBUS FUEL SELECTION	AV	42	AO	42
LMV SETPOINT W1	AV	43	AO	43
LMV SETPOINT W2	AV	44	AO	44
LMV WEEKDAY	AV	45	AO	45

Point List BACnet and Metasys N2 - LMV5 (continued)

Point Name	BACnet Obj Type	BACnet Obj ID	N2 Data Type	N2 Point Address
LMV YEAR 2-DIGIT	AV	46	AO	46
LMV MONTH	AI	47	AI	47
LMV DAY	AI	48	AI	48
LMV HOUR	AV	49	AO	49
LMV MINUTE	AI	50	AI	50
LMV SECOND	AI	51	AI	51
LMV HOURS RUN GAS RESET	AV	52	AO	52
LMV HOURS RUN OIL S1 RESET	AV	53	AO	53
LMV HOURS RUN OIL S2 RESET	AV	54	AO	54
LMV HOURS RUN OIL S3 RESET	AV	55	AO	55
LMV HOURS RUN TOTAL RESET	AV	56	AO	56
LMV HOURS RUN TOTAL FIXED	AI	57	AI	57
LMV HOURS CONNECT TO POWER	AI	58	AI	58
LMV STARTUPS GAS RESET	AV	59	AO	59
LMV STARTUPS OIL RESET	AV	60	AO	60
LMV STARTUPS TOTAL RESET	AV	61	AO	61
LMV STARTUPS TOTAL FIXED	AI	62	AI	62
LMV TOTAL VOLUME GAS	AV	63	AO	63
LMV TOTAL VOLUME OIL	AV	64	AO	64
LMV NUMBER OF LOCKOUTS	AI	65	AI	65
LMV EXTRA TEMP SENSOR	AI	66	AI	66
LMV AZL5 PARAMETER SET CODE	AI	75	AI	75
LMV AZL5 PARAMETER SET VER	AI	76	AI	76
LMV AZL5 ID DATE YEAR 2-DIGIT	AI	77	AI	77
LMV AZL5 ID DATE MONTH	AI	78	AI	78
LMV AZL5 ID DATE DAY	AI	79	AI	79
LMV AZL5 ID NUMBER	AI	80	AI	80
LMV BC PARAMETER SET CODE	AI	89	AI	89
LMV BC PARAMETER SET VER	AI	90	AI	90
LMV BC ID DATE YEAR 2-DIGIT	AI	91	AI	91
LMV BC ID DATE MONTH	AI	92	AI	92
LMV BURNER CNTRL ID DATE DAY	AI	93	AI	93
LMV BURNER CNTRL ID NUMBER	AI	94	AI	94
LMV SOFTWARE VERSION AZL	AI	95	AI	95
LMV SW VER BURNER CONTROL	AI	96	AI	96
LMV SW VER LOAD CONTROL	AI	97	AI	97
LMV MINIMUM OUTPUT GAS	AI	106	AI	106
LMV MAXIMUM OUTPUT GAS	AI	107	AI	107
LMV MINIMUM OUTPUT OIL	AI	108	AI	108
LMV MAXIMUM OUTPUT OIL	AI	109	AI	109
LMV LOAD LIMIT MODULATING	AV	110	AO	110
LMV LOAD LIMIT STAGING	AV	111	AO	111
LMV TEMP LIMIT ON THRESHOLD	AI	112	AI	112
LMV RANGE TEMP SENSOR	AI	113	AI	113
LMV ADAPTION ACTIVE	AI	114	AI	114

Point List BACnet and Metasys N2 - LMV5 (continued)

Point Name	BACnet Obj Type	BACnet Obj ID	N2 Data Type	N2 Point Address
LMV ADAPTION STATE	AI	115	AI	115
LMV START ADAPTION	AV	116	AO	116
LMV ADAPTION OUTPUT	AV	117	AO	117
LMV P-VALUE	AV	118	AO	118
LMV I-VALUE	AV	119	AO	119
LMV D-VALUE	AV	120	AO	120
LMV LOCKOUT ERR CODE CURR	AI	121	AI	121
LMV LOCKOUT DIAG CODE CURR	AI	122	AI	122
LMV LOCKOUT ERR CLASS CURR	AI	123	AI	123
LMV LOCKOUT ERR PHASE CURR	AI	124	AI	124
LMV LOCKOUT FUEL CURR	AI	125	AI	125
LMV LOCKOUT OUTPUT CURR	AI	126	AI	126
LMV LOCKOUT YEAR 2-DIG CURR	AI	127	AI	127
LMV LOCKOUT MONTH CURR	AI	128	AI	128
LMV LOCKOUT DAY CURR	AI	129	AI	129
LMV LOCKOUT HOUR CURR	AI	130	AI	130
LMV LOCKOUT MINUTE CURR	AI	131	AI	131
LMV LOCKOUT SECOND CURR	AI	132	AI	132
LMV LOCKOUT STARTUPS CURR	AI	133	AI	133
LMV LOCKOUT HOURS CURR	AI	134	AI	134
LMV ERROR ERROR CODE CURR	AI	135	AI	135
LMV ERROR DIAG CODE CURR	AI	136	AI	136
LMV ERROR ERROR CLASS CURR	AI	137	AI	137
LMV ERROR ERROR PHASE CURR	AI	138	AI	138
LMV ERROR FUEL CURR	AI	139	AI	139
LMV ERROR OUTPUT CURR	AI	140	AI	140
LMV ERROR STARTUPS CURR	AI	141	AI	141
LMV CONTROLLER SWITCH	BI	1	DI	1
LMV FAN CONTACTOR	BI	2	DI	2
LMV OIL SELECTED	BI	3	DI	3
LMV GAS SELECTED	BI	4	DI	4
LMV OIL PRESS SW MAX	BI	5	DI	5
LMV OIL PRESS SW MIN	BI	6	DI	6
LMV VALVE PROVING SW	BI	7	DI	7
LMV SAFETY LOOP	BI	8	DI	8
LMV GAS PRESS SW MIN	BI	9	DI	9
LMV GAS PRESS SW MAX	BI	10	DI	10
LMV AIR PRESSURE SW	BI	11	DI	11
LMV START RELEASE OIL	BI	12	DI	12
LMV HEAVY OIL START	BI	13	DI	13
LMV ALARM	BI	14	DI	14
LMV IGNITION	BI	15	DI	15
LMV START SIGNAL	BI	16	DI	16
LMV FAN OUTPUT	BI	17	DI	17
LMV OIL PUMP	BI	18	DI	18

Point List BACnet and Metasys N2 - LMV5 (continued)

Point Name	BACnet Obj Type	BACnet Obj ID	N2 Data Type	N2 Point Address
LMV FUEL VALVE SV OIL	BI	19	DI	19
LMV FUEL VALVE V1 OIL	BI	20	DI	20
LMV FUEL VALVE V2 OIL	BI	21	DI	21
LMV FUEL VALVE V3 OIL	BI	22	DI	22
LMV FUEL VALVE SV GAS	BI	23	DI	23
LMV FUEL VALVE V1 GAS	BI	24	DI	24
LMV FUEL VALVE V2 GAS	BI	25	DI	25
LMV FUEL VALVE PV GAS	BI	26	DI	26

Point List LonWorks - LMV5

Point Name	LonWorks Input	LonWorks Output
LMV PHASE	not writable	nvo(node)LmvPhase
LMV FUEL ACTUATOR	not writable	nvo(node)LmvFuelActuator
LMV GAS ACTUATOR	not writable	nvo(node)LmvGasActuator
LMV OIL ACTUATOR	not writable	nvo(node)LmvOilActuator
LMV AIR ACTUATOR	not writable	nvo(node)LmvAirActuator
LMV AUX1 ACTUATOR	not writable	nvo(node)LmvAux1Actuator
LMV AUX2 ACTUATOR	not writable	nvo(node)LmvAux2Actuator
LMV AUX3 ACTUATOR	not writable	nvo(node)LmvAux3Actuator
LMV VSD OUTPUT	not writable	nvo(node)LmvVsdOutput
LMV CURRENT FUEL	not writable	nvo(node)LmvCurrentFuel
LMV CURRENT OUTPUT	not writable	nvo(node)LmvCurrentOutput
LMV CURRENT SETPOINT	not writable	nvo(node)LmvCurrentSetpoint
LMV ACTUAL VALUE	not writable	nvo(node)LmvActualValue
LMV FLAME SIGNAL	not writable	nvo(node)LmvFlameSignal
LMV FUEL THROUGHPUT	not writable	nvo(node)LmvFuelThroughput
LMV CURRENT O ₂	not writable	nvo(node)LmvCurrentO2
LMV GAS UNIT	not writable	nvo(node)LmvGasUnit
LMV OIL UNIT	not writable	nvo(node)LmvOilUnit
LMV TEMPERATURE UNIT	not writable	nvo(node)LmvTemperatureUnit
LMV PRESSURE UNIT	not writable	nvo(node)LmvPressureUnit
LMV SENSOR SELECTION	not writable	nvo(node)LmvSensorSelection
LMV STARTUP COUNTER	not writable	nvo(node)LmvStartupCounter
LMV HOUR COUNTER	not writable	nvo(node)LmvHourCounter
LMV CURRENT ERROR CODE	not writable	nvo(node)LmvCurrErrCode
LMV CURRENT DIAGNOSTIC CODE	not writable	nvo(node)LmvCurrDiagCode
LMV CURRENT ERROR CLASS	not writable	nvo(node)LmvCurrErrClass
LMV CURRENT ERROR PHASE	not writable	nvo(node)LmvCurrErrPhase
LMV TEMP LIMIT OFF THRESHOLD	not writable	nvo(node)LmvTempLimOffThres
LMV SUPPLY AIR TEMPERATURE	not writable	nvo(node)LmvSuppAirTemp
LMV FLUE GAS TEMPERATURE	not writable	nvo(node)LmvFlueGasTemp
LMV COMBUSTION EFFICIENCY	not writable	nvo(node)LmvCombEff
LMV INPUT WORD	not writable	nvo(node)LmvInputWord
LMV OUTPUT WORD	not writable	nvo(node)LmvOutputWord
LMV PROGRAM STOP	nvi(node)LmvProgramStop	nvo(node)LmvProgramStop
LMV LOAD CONTROL MODE	not writable	nvo(node)LmvLoadControlMode
LMV MANUAL/AUTOMATIC	nvi(node)LmvLoadControlMode	nvo(node)LmvManualAutomatic
LMV MODBUS LOCAL/REMOTE	nvi(node)LmvModbusLocRem	nvo(node)LmvModbusLocRem
LMV MODBUS WATCHDOG	nvi(node)LmvModbusWatchdog	nvo(node)LmvModbusWatchdog
LMV MODBUS OPERATING MODE	nvi(node)LmvModbusOpMode	nvo(node)LmvModbusOpMode
LMV MODBUS SETPOINT W3	nvi(node)LmvModbusSetpointW3	nvo(node)LmvModbusSetpointW3
LMV MODBUS OUTPUT	nvi(node)LmvModbusOutput	nvo(node)LmvModbusOutput
LMV MODBUS FUEL SELECTION	nvi(node)LmvModbusFuelSel	nvo(node)LmvModbusFuelSel
LMV SETPOINT W1	nvi(node)LmvSetpointW1	nvo(node)LmvSetpointW1
LMV SETPOINT W2	nvi(node)LmvSetpointW2	nvo(node)LmvSetpointW2
LMV WEEKDAY	AV	nvo(node)LmvWeekday

Point List LonWorks - LMV5 (continued)

Point Name	LonWorks Input	LonWorks Output
LMV YEAR 2-DIGIT	not writable	nvo(node)LmvDateTime
LMV MONTH	not writable	" "
LMV DAY	not writable	" "
LMV HOUR	not writable	" "
LMV MINUTE	not writable	" "
LMV SECOND	not writable	" "
LMV HOURS RUN GAS RESET	nvi(node)LmvHrsRunGasRst	nvo(node)LmvHrsRunGasRst
LMV HOURS RUN OIL S1 RESET	nvi(node)LmvHrsRunOilS1Rst	nvo(node)LmvHrsRunOilS1Rst
LMV HOURS RUN OIL S2 RESET	nvi(node)LmvHrsRunOilS2Rst	nvo(node)LmvHrsRunOilS2Rst
LMV HOURS RUN OIL S3 RESET	nvi(node)LmvHrsRunOilS3Rst	nvo(node)LmvHrsRunOilS3Rst
LMV HOURS RUN TOTAL RESET	nvi(node)LmvHrsRunTotalRst	nvo(node)LmvHrsRunTotalRst
LMV HOURS RUN TOTAL FIXED	not writable	nvo(node)LmvHrsRunTotFixed
LMV HOURS CONNECT TO POWER	not writable	nvo(node)LmvHrsConnToPower
LMV STARTUPS GAS RESET	nvi(node)LmvStartupsGasRst	nvo(node)LmvStartupsGasRst
LMV STARTUPS OIL RESET	nvi(node)LmvStartupsOilRst	nvo(node)LmvStartupsOilRst
LMV STARTUPS TOTAL RESET	nvi(node)LmvStartupsTotRst	nvo(node)LmvStartupsTotRst
LMV STARTUPS TOTAL FIXED	not writable	nvo(node)LmvStartupsTotFixed
LMV TOTAL VOLUME GAS	nvi(node)LmvTotalVolumeGas	nvo(node)LmvTotalVolumeGas
LMV TOTAL VOLUME OIL	nvi(node)LmvTotalVolumeOil	nvo(node)LmvTotalVolumeOil
LMV NUMBER OF LOCKOUTS	not writable	nvo(node)LmvNumOfLockouts
LMV EXTRA TEMP SENSOR	not writable	nvo(node)LmvExtraTempSensor
LMV AZL5 PARAMETER SET CODE	not writable	nvo(node)LmvAzl5ParamSetCode
LMV AZL5 PARAMETER SET VER	not writable	nvo(node)LmvAzl5ParamSetVer
LMV AZL5 ID DATE YEAR 2-DIGIT	not writable	nvo(node)LmvAzl5IdDate
LMV AZL5 ID DATE MONTH	not writable	nvo(node)LmvAzl5IdNumber
LMV AZL5 ID DATE DAY	not writable	nvo(node)LmvBcParamSetCode
LMV AZL5 ID NUMBER	not writable	nvo(node)LmvAzl5IdNumber
LMV BC PARAMETER SET CODE	not writable	nvo(node)LmvBcParamSetCode
LMV BC PARAMETER SET VER	not writable	nvo(node)LmvBcParamSetVer
LMV BC ID DATE YEAR 2-DIGIT	not writable	nvo(node)LmvBcIdDate
LMV BC ID DATE MONTH	not writable	nvo(node)LmvBrnCntrlIdNumber
LMV BURNER CNTRL ID DATE DAY	not writable	nvo(node)LmvSwVersionAzl
LMV BURNER CNTRL ID NUMBER	not writable	nvo(node)LmvBrnCntrlIdNumber
LMV SOFTWARE VERSION AZL	not writable	nvo(node)LmvSwVersionAzl
LMV SW VER BURNER CONTROL	not writable	nvo(node)LmvSwVerBrnCntrl
LMV SW VER LOAD CONTROL	not writable	nvo(node)LmvSwVerLoadControl
LMV MINIMUM OUTPUT GAS	not writable	nvo(node)LmvMinimumOutputGas
LMV MAXIMUM OUTPUT GAS	not writable	nvo(node)LmvMaximumOutputGas
LMV MINIMUM OUTPUT OIL	not writable	nvo(node)LmvMinimumOutputOil
LMV MAXIMUM OUTPUT OIL	not writable	nvo(node)LmvMaximumOutputOil
LMV LOAD LIMIT MODULATING	nvi(node)LmvLoadLimitMod	nvo(node)LmvLoadLimitMod
LMV LOAD LIMIT STAGING	nvi(node)LmvLoadLimitStaging	nvo(node)LmvLoadLimitStaging
LMV TEMP LIMIT ON THRESHOLD	not writable	nvo(node)LmvTempLimOnThres
LMV RANGE TEMP SENSOR	not writable	nvo(node)LmvRangeTempSensor
LMV ADAPTION ACTIVE	not writable	nvo(node)LmvAdaptionActive

Point List LonWorks - LMV5 (continued)

Point Name	LonWorks Input	LonWorks Output
LMV ADAPTION STATE	not writable	nvo(node)LmvAdaptionState
LMV START ADAPTION	nvi(node)LmvStartAdaption	nvo(node)LmvStartAdaption
LMV ADAPTION OUTPUT	nvi(node)LmvAdaptionOutput	nvo(node)LmvAdaptionOutput
LMV P-VALUE	nvi(node)LmvP-Value	nvo(node)LmvP-Value
LMV I-VALUE	nvi(node)Lmvl-Value	nvo(node)Lmvl-Value
LMV D-VALUE	nvi(node)LmvD-Value	nvo(node)LmvD-Value
LMV LOCKOUT ERR CODE CURR	not writable	nvo(node)LmvLoErrorCodeCurr
LMV LOCKOUT DIAG CODE CURR	not writable	nvo(node)LmvLoDiagCodeCurr
LMV LOCKOUT ERR CLASS CURR	not writable	nvo(node)LmvLoErrClassCurr
LMV LOCKOUT ERR PHASE CURR	not writable	nvo(node)LmvLoErrPhaseCurr
LMV LOCKOUT FUEL CURR	not writable	nvo(node)LmvLoFuelCurr
LMV LOCKOUT OUTPUT CURR	not writable	nvo(node)LmvLoOutputCurr
LMV LOCKOUT YEAR 2-DIG CURR	not writable	nvo(node)LmvLoDateTimeCurr
LMV LOCKOUT MONTH CURR	not writable	" "
LMV LOCKOUT DAY CURR	not writable	" "
LMV LOCKOUT HOUR CURR	not writable	" "
LMV LOCKOUT MINUTE CURR	not writable	" "
LMV LOCKOUT SECOND CURR	not writable	" "
LMV LOCKOUT STARTUPS CURR	not writable	nvo(node)LmvLoStartupsCurr
LMV LOCKOUT HOURS CURR	not writable	nvo(node)LmvLoHoursCurr
LMV ERROR ERROR CODE CURR	not writable	nvo(node)LmvErrErrCodeCurr
LMV ERROR DIAG CODE CURR	not writable	nvo(node)LmvErrDiagCodeCurr
LMV ERROR ERROR CLASS CURR	not writable	nvo(node)LmvErrErrClassCurr
LMV ERROR ERROR PHASE CURR	not writable	nvo(node)LmvErrErrPhaseCurr
LMV ERROR FUEL CURR	not writable	nvo(node)LmvErrFuelCurr
LMV ERROR OUTPUT CURR	not writable	nvo(node)LmvErrOutputCurr
LMV ERROR STARTUPS CURR	not writable	nvo(node)LmvErrStartupsCurr
LMV CONTROLLER SWITCH	not writable	nvo(node)LmvControllerSwitch
LMV FAN CONTACTOR	not writable	nvo(node)LmvFanContactor
LMV OIL SELECTED	not writable	nvo(node)LmvOilSelected
LMV GAS SELECTED	not writable	nvo(node)LmvGasSelected
LMV OIL PRESS SW MAX	not writable	nvo(node)LmvOilPressSwMax
LMV OIL PRESS SW MIN	not writable	nvo(node)LmvOilPressSwMin
LMV VALVE PROVING SW	not writable	nvo(node)LmvValveProvingSw
LMV SAFETY LOOP	not writable	nvo(node)LmvSafetyLoop
LMV GAS PRESS SW MIN	not writable	nvo(node)LmvGasPressSwMin
LMV GAS PRESS SW MAX	not writable	nvo(node)LmvGasPressSwMax
LMV AIR PRESSURE SW	not writable	nvo(node)LmvAirPressureSw
LMV START RELEASE OIL	not writable	nvo(node)LmvStartReleaseOil
LMV HEAVY OIL START	not writable	nvo(node)LmvHeavyOilStart
LMV ALARM	not writable	nvo(node)LmvAlarm
LMV IGNITION	not writable	nvo(node)LmvIgnition
LMV START SIGNAL	not writable	nvo(node)LmvStartSignal
LMV FAN OUTPUT	not writable	nvo(node)LmvFanOutput
LMV OIL PUMP	not writable	nvo(node)LmvOilPump

Point List LonWorks - LMV5 (continued)

Point Name	LonWorks Input	LonWorks Output
LMV FUEL VALVE SV OIL	not writable	nvo(node)LmvFuelValveSvOil
LMV FUEL VALVE V1 OIL	not writable	nvo(node)LmvFuelValveV1Oil
LMV FUEL VALVE V2 OIL	not writable	nvo(node)LmvFuelValveV2Oil
LMV FUEL VALVE V3 OIL	not writable	nvo(node)LmvFuelValveV3Oil
LMV FUEL VALVE SV GAS	not writable	nvo(node)LmvFuelValveSvGas
LMV FUEL VALVE V1 GAS	not writable	nvo(node)LmvFuelValveV1Gas
LMV FUEL VALVE V2 GAS	not writable	nvo(node)LmvFuelValveV2Gas
LMV FUEL VALVE PV GAS	not writable	nvo(node)LmvFuelValvePvGas

(node) = Modbus address. Example: Point for device with Modbus address 1 would be nvo1xxx.

Point List BACnet and Metasys N2 - RWF10

Point Name	BACnet Obj Type	BACnet Obj ID	N2 Data Type	N2 Point Address
PROCESS VARIABLE	AI	1	AI	1
STATUS WORD	AI	2	AI	2
ANALOG OUTPUT	AI	3	AI	3
CURRENT SETPOINT	AI	4	AI	4
SETPOINT ALARM 1	AI	5	AI	5
SETPOINT ALARM 2	AI	6	AI	6
PROPORTIONAL BAND	AI	7	AI	7
INTEGRAL TIME	AI	8	AI	8
DERIVATIVE TIME	AI	9	AI	9
HYSTERESIS ALARM 1	AI	10	AI	10
HYSTERESIS ALARM 2	AI	11	AI	11
OUTPUT ALARM 1 BURNER	BI	1	DI	1
OUTPUT ALARM 2 LF HOLD	BI	2	DI	2

Point List LonWorks - RWF10

Point Name	LonWorks Input	LonWorks Output
PROCESS VARIABLE	not writable	nvo(node)ProcessVariable
STATUS WORD	not writable	nvo(node)StatusWord
ANALOG OUTPUT	not writable	nvo(node)AnalogOutput
CURRENT SETPOINT	not writable	nvo(node)CurrentSetpoint
SETPOINT ALARM 1	not writable	nvo(node)SetpointAlarm1
SETPOINT ALARM 2	not writable	nvo(node)SetpointAlarm2
PROPORTIONAL BAND	not writable	nvo(node)ProportionalBand
INTEGRAL TIME	not writable	nvo(node)IntegralTime
DERIVATIVE TIME	not writable	nvo(node)DerivativeTime
HYSTERESIS ALARM 1	not writable	nvo(node)HysteresisAlarm1
HYSTERESIS ALARM 2	not writable	nvo(node)HysteresisAlarm2
OUTPUT ALARM 1 BURNER	not writable	nvo(node)OutputAlarm1Burner
OUTPUT ALARM 2 LF HOLD	not writable	nvo(node)OutputAlarm2LfHold

(node) = Modbus address. Example: Point for device with Modbus address 1 would be nvo1xxx.

Point List BACnet and Metasys N2 - RWF40

Point Name	BACnet Obj Type	BACnet Obj ID	N2 Data Type	N2 Point Address
INPUT 1 E1	AI	1	AI	1
INPUT 2 E2	AI	2	AI	2
INPUT 3 E3	AI	3	AI	3
CURRENT SETPOINT CSP	AV	4	AO	4
FIRST SETPOINT SP1	AV	5	AO	5
SECOND SETPOINT SP2	AV	6	AO	6
ALARM LIMIT COMPARATOR AL	AV	7	AO	7
PROPORTIONAL BAND Pb1	AV	8	AO	8
DERIVATIVE ACTION TIME dt	AV	9	AO	9
INTEGRAL ACTION TIME rt	AV	10	AO	10
DEAD BAND db	AV	11	AO	11
ACTUATOR RUNNING TIME tt	AV	12	AO	12
ON HYSTERESIS HYS1	AV	13	AO	13
OFF HYSTERESIS BOTTOM HYS2	AV	14	AO	14
OFF HYSTERESIS TOP HYS3	AV	15	AO	15
REACTION THRESHOLD q	AV	16	AO	16
HEATING CURVE SLOPE H	AV	17	AO	17
PARALLEL DISPLACEMENT P	AV	18	AO	18
INPUT 1 SCALE LOW SCL	AV	19	AO	19
INPUT 1 SCALE HIGH SCH	AV	20	AO	20
INPUT 2 SCALE LOW SCL2	AV	21	AO	21
INPUT 2 SCALE HIGH SCH2	AV	22	AO	22
SETPOINT LIMIT SCALE LOW SPL	AV	23	AO	23
SETPOINT LIMIT SCALE HIGH SPH	AV	24	AO	24
OFFSET INPUT 1 OFF1	AV	25	AO	25
OFFSET INPUT 2 OFF2	AV	26	AO	26
OFFSET INPUT 3 OFF3	AV	27	AO	27
HYSTERESIS LIMIT COMP HYST	AV	28	AO	28
FILTER INPUT 1 dF1	AV	29	AO	29
FILTER INPUT 3 dF3	AV	30	AO	30
MODBUS WATCHDOG dtt	AV	31	AO	31
ACTUAL VALUE LIMIT LOW oLLo	AI	32	AI	32
ACTUAL VALUE LIMIT HIGH oLHi	AI	33	AI	33
INPUT 3 UNFILTERED TEMP	AI	34	AI	34
REMOTE OPERATING MODE REM	AV	35	AO	35
REMOTE MODE OFF ROFF	AV	36	AO	36
REMOTE ON HYSTERESIS RHYS1	AV	37	AO	37
REMOTE OFF HYST BOT RHYS2	AV	38	AO	38
REMOTE OFF HYST TOP RHYS3	AV	39	AO	39
REMOTE SETPOINT SPR	AV	40	AO	40
REMOTE BURNER OUTPUT RK1	AV	41	AO	41
REMOTE K2 OUTPUT RK2	AV	42	AO	42
REMOTE K3 OUTPUT RK3	AV	43	AO	43
REMOTE K6 OUTPUT RK6	AV	44	AO	44
REMOTE STAGE MODE RSTEP	AV	45	AO	45

Point List BACnet and Metasys N2 - RWF40 (continued)

Point Name	BACnet Obj Type	BACnet Obj ID	N2 Data Type	N2 Point Address
REMOTE OUTPUT RY	AV	46	AO	46
INPUT 1 FAULT	BI	1	DI	1
INPUT 2 FAULT	BI	2	DI	2
INPUT 3 FAULT	BI	3	DI	3
STAGE MODE	BI	4	DI	4
MANUAL OPERATION	BI	5	DI	5
BINARY INPUT 1	BI	6	DI	6
BINARY INPUT 2	BI	7	DI	7
STAT ACTIVE	BI	8	DI	8
UP ACTIVE	BI	9	DI	9
DOWN ACTIVE	BI	10	DI	10
K6 ACTIVE	BI	11	DI	11

Point List LonWorks - RWF40

Point Name	LonWorks Input	LonWorks Output
INPUT 1 E1	not writable	nvo(node)Input1E1
INPUT 2 E2	not writable	nvo(node)Input2E2
INPUT 3 E3	not writable	nvo(node)Input3E3
CURRENT SETPOINT CSP	nvi(node)CurrentSetpointCsp	nvo(node)CurrentSetpointCsp
FIRST SETPOINT SP1	nvi(node)FirstSetpointSp1	nvo(node)FirstSetpointSp1
SECOND SETPOINT SP2	nvi(node)SecondSetpointSp2	nvo(node)SecondSetpointSp2
ALARM LIMIT COMPARATOR AL	nvi(node)AlarmLimitCompAl	nvo(node)AlarmLimitCompAl
PROPORTIONAL BAND Pb1	nvi(node)ProportionalBandPb1	nvo(node)ProportionalBandPb1
DERIVATIVE ACTION TIME dt	nvi(node)DerivativeTimeDt	nvo(node)DerivativeTimeDt
INTEGRAL ACTION TIME rt	nvi(node)IntegralTimeRt	nvo(node)IntegralTimeRt
DEAD BAND db	nvi(node)DeadBandDb	nvo(node)DeadBandDb
ACTUATOR RUNNING TIME tt	nvi(node)ActuatorRunTimeTt	nvo(node)ActuatorRunTimeTt
ON HYSTERESIS HYS1	nvi(node)OnHysteresisHys1	nvo(node)OnHysteresisHys1
OFF HYSTERESIS BOTTOM HYS2	nvi(node)OffHystBotHys2	nvo(node)OffHystBotHys2
OFF HYSTERESIS TOP HYS3	nvi(node)OffHystTopHys3	nvo(node)OffHystTopHys3
REACTION THRESHOLD q	nvi(node)ReactionThresholdQ	nvo(node)ReactionThresholdQ
HEATING CURVE SLOPE H	nvi(node)HeatingCurveSlopeH	nvo(node)HeatingCurveSlopeH
PARALLEL DISPLACEMENT P	nvi(node)ParallelDispP	nvo(node)ParallelDispP
INPUT 1 SCALE LOW SCL	nvi(node)Input1ScaleLowScl	nvo(node)Input1ScaleLowScl
INPUT 1 SCALE HIGH SCH	nvi(node)Input1ScaleHighSch	nvo(node)Input1ScaleHighSch
INPUT 2 SCALE LOW SCL2	nvi(node)Input2ScaleLowScl2	nvo(node)Input2ScaleLowScl2
INPUT 2 SCALE HIGH SCH2	nvi(node)Input2ScaleHighSch2	nvo(node)Input2ScaleHighSch2
SETPOINT LIMIT SCALE LOW SPL	nvi(node)SpLimitScaleLowSpl	nvo(node)SpLimitScaleLowSpl
SETPOINT LIMIT SCALE HIGH SPH	nvi(node)SpLimitScaleHighSph	nvo(node)SpLimitScaleHighSph
OFFSET INPUT 1 OFF1	nvi(node)OffsetInput1Off1	nvo(node)OffsetInput1Off1
OFFSET INPUT 2 OFF2	nvi(node)OffsetInput2Off2	nvo(node)OffsetInput2Off2
OFFSET INPUT 3 OFF3	nvi(node)OffsetInput3Off3	nvo(node)OffsetInput3Off3
HYSTERESIS LIMIT COMP HYST	nvi(node)HystLimitCompHyst	nvo(node)HystLimitCompHyst
FILTER INPUT 1 dF1	nvi(node)FilterInput1Df1	nvo(node)FilterInput1Df1
FILTER INPUT 3 dF3	nvi(node)FilterInput3Df3	nvo(node)FilterInput3Df3
MODBUS WATCHDOG dtt	nvi(node)ModbusWatchdogDtt	nvo(node)ModbusWatchdogDtt
ACTUAL VALUE LIMIT LOW oLLo	not writable	nvo(node)ActValLimitLowOllO
ACTUAL VALUE LIMIT HIGH oLHi	not writable	nvo(node)ActValLimitHighOlhi
INPUT 3 UNFILTERED TEMP	not writable	nvo(node)Inp3UnfilteredTemp
REMOTE OPERATING MODE REM	nvi(node)RemOperatingModeRem	nvo(node)RemOperatingModeRem
REMOTE MODE OFF ROFF	nvi(node)RemoteModeOffRoff	nvo(node)RemoteModeOffRoff
REMOTE ON HYSTERESIS RHYS1	nvi(node)RemOnHystRhys1	nvo(node)RemoteOnHystRhys1
REMOTE OFF HYST BOT RHYS2	nvi(node)RemOffHystBotRhys2	nvo(node)RemOffHystBotRhys2
REMOTE OFF HYST TOP RHYS3	nvi(node)RemOffHystTopRhys3	nvo(node)RemOffHystTopRhys3
REMOTE SETPOINT SPR	nvi(node)RemoteSetpointSpr	nvo(node)RemoteSetpointSpr
REMOTE BURNER OUTPUT RK1	nvi(node)RemBurnerOutputRk1	nvo(node)RemBurnerOutputRk1
REMOTE K2 OUTPUT RK2	nvi(node)RemoteK2OutputRk2	nvo(node)RemoteK2OutputRk2
REMOTE K3 OUTPUT RK3	nvi(node)RemoteK3OutputRk3	nvo(node)RemoteK3OutputRk3
REMOTE K6 OUTPUT RK6	nvi(node)RemoteK6OutputRk6	nvo(node)RemoteK6OutputRk6
REMOTE STAGE MODE RSTEP	nvi(node)RemStageModeRstep	nvo(node)RemStageModeRstep

Point List LonWorks - RWF40 (continued)

Point Name	LonWorks Input	LonWorks Output
REMOTE OUTPUT RY	nvi(node)RemoteOutputRy	not readable
INPUT 1 FAULT	not writable	nvo(node)Input1Fault
INPUT 2 FAULT	not writable	nvo(node)Input2Fault
INPUT 3 FAULT	not writable	nvo(node)Input3Fault
STAGE MODE	not writable	nvo(node)StageMode
MANUAL OPERATION	not writable	nvo(node)ManualOperation
BINARY INPUT 1	not writable	nvo(node)BinaryInput1
BINARY INPUT 2	not writable	nvo(node)BinaryInput2
STAT ACTIVE	not writable	nvo(node)StatActive
UP ACTIVE	not writable	nvo(node)UpActive
DOWN ACTIVE	not writable	nvo(node)DownActive
K6 ACTIVE	not writable	nvo(node)K6Active

(node) = Modbus address. Example: Point for device with Modbus address 1 would be nvo1xxx.

Point List BACnet and Metasys N2 - RWF55

Point Name	BACnet Obj Type	BACnet Obj ID	N2 Data Type	N2 Point Address
INPUT 1 X1	AI	1	AI	1
INPUT 2 X2	AI	2	AI	2
INPUT 3 X3	AI	3	AI	3
CURRENT SETPOINT WR	AI	4	AI	4
FIRST SETPOINT SP1	AV	5	AO	5
SECOND SETPOINT SP2	AV	6	AO	6
REMOTE OPERATING MODE REM	AV	7	AO	7
REMOTE MODE OFF ROFF	AV	8	AO	8
REMOTE ON HYSTERESIS RHYS1	AV	9	AO	9
REMOTE OFF HYST BOTTOM RHYS2	AV	10	AO	10
REMOTE OFF HYST TOP RHYS3	AV	11	AO	11
REMOTE SETPOINT SPR	AV	12	AO	12
REMOTE BURNER OUTPUT RK1	AV	13	AO	13
REMOTE K2 OUTPUT RK2	AV	14	AO	14
REMOTE K3 OUTPUT RK3	AV	15	AO	15
REMOTE K6 OUTPUT RK6	AV	16	AO	16
REMOTE STAGE MODE RSTEP	AV	17	AO	17
REMOTE OUTPUT RY	AV	18	AO	18
REM ON HYST COOLING RHYS4	AV	19	AO	19
REM OFF HYST BTM COOL RHYS5	AV	20	AO	20
REM OFF HYST TOP COOL RHYS6	AV	21	AO	21
INPUT 3 UNFILTERED TEMP	AI	22	AI	22
ACTUAL OUTPUT Y	AI	23	AI	23
BURNER ALARM	AI	24	AI	24
RAMP FUNCTION FnCt	AV	25	AO	25
RAMP SLOPE rASL	AV	26	AO	26
TOLERANCE BAND RAMP toLP	AV	27	AO	27
LIMIT VALUE rAL	AV	28	AO	28
ALARM RELAY FUNCTION FnAL	AV	29	AO	29
ALARM LIMIT COMPARATOR AL	AV	30	AO	30
HYSTERESIS LIMIT COMP HYST	AV	31	AO	31
MODBUS WATCHDOG dtt	AV	32	AO	32
FILTER INPUT 1 dF1	AV	33	AO	33
FILTER INPUT 2 dF2	AV	34	AO	34
FILTER INPUT 3 dF3	AV	35	AO	35
ACTUAL VALUE LIMIT LOW oLLo	AI	36	AI	36
ACTUAL VALUE LIMIT HIGH oLHi	AI	37	AI	37
PROPORTIONAL BAND Pb1	AV	38	AO	38
DERIVATIVE ACTION TIME dt	AV	39	AO	39
INTEGRAL ACTION TIME rt	AV	40	AO	40
DEAD BAND db	AV	41	AO	41
ACTUATOR RUNNING TIME tt	AV	42	AO	42
ON HYSTERESIS HYS1	AV	43	AO	43
OFF HYSTERESIS BOTTOM HYS2	AV	44	AO	44
OFF HYSTERESIS TOP HYS3	AV	45	AO	45

Point List BACnet and Metasys N2 - RWF55 (continued)

Point Name	BACnet Obj Type	BACnet Obj ID	N2 Data Type	N2 Point Address
ON HYST COOLING HYS4	AV	46	AO	46
OFF HYST BTM COOLING HYS5	AV	47	AO	47
OFF HYST TOP COOLING HYS6	AV	48	AO	48
REACTION THRESHOLD q	AV	49	AO	49
OUTSIDE TEMPERATURE 1 At1	AV	50	AO	50
BOILER TEMPERATURE 1 Ht1	AV	51	AO	51
OUTSIDE TEMPERATURE 2 At2	AV	52	AO	52
BOILER TEMPERATURE 2 Ht2	AV	53	AO	53
INPUT 1 SCALE LOW SCL1	AV	54	AO	54
INPUT 1 SCALE HIGH SCH1	AV	55	AO	55
OFFSET INPUT 1 OFF1	AV	56	AO	56
INPUT 2 SCALE LOW SCL2	AV	57	AO	57
INPUT 2 SCALE HIGH SCH2	AV	58	AO	58
OFFSET INPUT 2 OFF2	AV	59	AO	59
OFFSET INPUT 3 OFF3	AV	60	AO	60
SETPOINT LIMIT SCALE LOW SPL	AV	61	AO	61
SETPOINT LIMIT SCALE HIGH SPH	AV	62	AO	62
INPUT 1 FAULT	BI	1	DI	1
INPUT 2 FAULT	BI	2	DI	2
INPUT 3 FAULT	BI	3	DI	3
STAGE MODE	BI	4	DI	4
MANUAL OPERATION	BI	5	DI	5
BINARY INPUT 1	BI	6	DI	6
BINARY INPUT 2	BI	7	DI	7
STAT ACTIVE	BI	8	DI	8
UP ACTIVE	BI	9	DI	9
DOWN ACTIVE	BI	10	DI	10
K6 ACTIVE	BI	11	DI	11

Point List LonWorks - RWF55

Point Name	LonWorks Input	LonWorks Output
INPUT 1 X1	not writable	nvo(node)Input1X1
INPUT 2 X2	not writable	nvo(node)Input2X2
INPUT 3 X3	not writable	nvo(node)Input3X3
CURRENT SETPOINT WR	not writable	nvo(node)CurrentSetpointWr
FIRST SETPOINT SP1	nvi(node)FirstSetpointSp1	nvo(node)FirstSetpointSp1
SECOND SETPOINT SP2	nvi(node)SecondSetpointSp2	nvo(node)SecondSetpointSp2
REMOTE OPERATING MODE REM	nvi(node)RemOperatingModeRem	nvo(node)RemOperatingModeRem
REMOTE MODE OFF ROFF	nvi(node)RemModeOffRoff	nvo(node)RemModeOffRoff
REMOTE ON HYSTERESIS RHYS1	nvi(node)RemOnHystRhys1	nvo(node)RemOnHystRhys1
REMOTE OFF HYST BOTTOM RHYS2	nvi(node)RemOffHystBotRhys2	nvo(node)RemOffHystBotRhys2
REMOTE OFF HYST TOP RHYS3	nvi(node)RemOffHystTopRhys3	nvo(node)RemOffHystTopRhys3
REMOTE SETPOINT SPR	nvi(node)RemSetpointSpr	nvo(node)RemSetpointSpr
REMOTE BURNER OUTPUT RK1	nvi(node)RemBurnerOutputRk1	nvo(node)RemBurnerOutputRk1
REMOTE K2 OUTPUT RK2	nvi(node)RemK2OutputRk2	nvo(node)RemK2OutputRk2
REMOTE K3 OUTPUT RK3	nvi(node)RemK3OutputRk3	nvo(node)RemK3OutputRk3
REMOTE K6 OUTPUT RK6	nvi(node)RemK6OutputRk6	nvo(node)RemK6OutputRk6
REMOTE STAGE MODE RSTEP	nvi(node)RemStageModeRstep	nvo(node)RemStageModeRstep
REMOTE OUTPUT RY	nvi(node)RemOutputRy	nvo(node)RemOutputRy
REM ON HYST COOLING RHYS4	nvi(node)RemOnHystCoolRhys4	nvo(node)RemOnHystCoolRhys4
REM OFF HYST BTM COOL RHYS5	nvi(node)ROffHysBtmCoolRhys5	nvo(node)ROffHysBtmCoolRhys5
REM OFF HYST TOP COOL RHYS6	nvi(node)ROffHysTopCoolRhys6	nvo(node)ROffHysTopCoolRhys6
INPUT 3 UNFILTERED TEMP	not writable	nvo(node)Inp3UnfilteredTemp
ACTUAL OUTPUT Y	not writable	nvo(node)ActualOutputY
BURNER ALARM	not writable	nvo(node)BurnerAlarm
RAMP FUNCTION FnCt	nvi(node)RampFunctionFnct	nvo(node)RampFunctionFnct
RAMP SLOPE rASL	nvi(node)RampSlopeRasl	nvo(node)RampSlopeRasl
TOLERANCE BAND RAMP toLP	nvi(node)TolBandRampTolp	nvo(node)TolBandRampTolp
LIMIT VALUE rAL	nvi(node)LimitValueRal	nvo(node)LimitValueRal
ALARM RELAY FUNCTION FnAL	nvi(node)AlarmRelayFuncFnal	nvo(node)AlarmRelayFuncFnal
ALARM LIMIT COMPARATOR AL	nvi(node)AlarmLimitCompAl	nvo(node)AlarmLimitCompAl
HYSTERESIS LIMIT COMP HYST	nvi(node)HystLimitCompHyst	nvo(node)HystLimitCompHyst
MODBUS WATCHDOG dtt	nvi(node)ModbusWatchdogDtt	nvo(node)ModbusWatchdogDtt
FILTER INPUT 1 dF1	nvi(node)FilterInput1Df1	nvo(node)FilterInput1Df1
FILTER INPUT 2 dF2	nvi(node)FilterInput2Df2	nvo(node)FilterInput2Df2
FILTER INPUT 3 dF3	nvi(node)FilterInput3Df3	nvo(node)FilterInput3Df3
ACTUAL VALUE LIMIT LOW oLLo	not writable	nvo(node)ActValLimitLowOlllo
ACTUAL VALUE LIMIT HIGH oLHi	not writable	nvo(node)ActValLimitHighOlhi
PROPORTIONAL BAND Pb1	nvi(node)ProportionalBandPb1	nvo(node)ProportionalBandPb1
DERIVATIVE ACTION TIME dt	nvi(node)DerivativeTimeDt	nvo(node)DerivativeTimeDt
INTEGRAL ACTION TIME rt	nvi(node)IntegralTimeRt	nvo(node)IntegralTimeRt
DEAD BAND db	nvi(node)DeadBandDb	nvo(node)DeadBandDb
ACTUATOR RUNNING TIME tt	nvi(node)ActuatorRunTimeTt	nvo(node)ActuatorRunTimeTt
ON HYSTERESIS HYS1	nvi(node)OnHystHys1	nvo(node)OnHystHys1
OFF HYSTERESIS BOTTOM HYS2	nvi(node)OffHystBotHys2	nvo(node)OffHystBotHys2
OFF HYSTERESIS TOP HYS3	nvi(node)OffHystTopHys3	nvo(node)OffHystTopHys3

Point List LonWorks - RWF55 (continued)

Point Name	LonWorks Input	LonWorks Output
ON HYST COOLING HYS4	nvi(node)OnHystCoolHys4	nvo(node)OnHystCoolHys4
OFF HYST BTM COOLING HYS5	nvi(node)OffHystBtmCoolHys5	nvo(node)OffHystBtmCoolHys5
OFF HYST TOP COOLING HYS6	nvi(node)OffHystTopCoolHys6	nvo(node)OffHystTopCoolHys6
REACTION THRESHOLD q	nvi(node)ReactionThresholdQ	nvo(node)ReactionThresholdQ
OUTSIDE TEMPERATURE 1 At1	nvi(node)OutsideTemp1At1	nvo(node)OutsideTemp1At1
BOILER TEMPERATURE 1 Ht1	nvi(node)BoilerTemp1Ht1	nvo(node)BoilerTemp1Ht1
OUTSIDE TEMPERATURE 2 At2	nvi(node)OutsideTemp2At2	nvo(node)OutsideTemp2At2
BOILER TEMPERATURE 2 Ht2	nvi(node)BoilerTemp2Ht2	nvo(node)BoilerTemp2Ht2
INPUT 1 SCALE LOW SCL1	nvi(node)Input1ScaleLowScl1	nvo(node)Input1ScaleLowScl1
INPUT 1 SCALE HIGH SCH1	nvi(node)Input1ScaleHighSch1	nvo(node)Input1ScaleHighSch1
OFFSET INPUT 1 OFF1	nvi(node)OffsetInput1Off1	nvo(node)OffsetInput1Off1
INPUT 2 SCALE LOW SCL2	nvi(node)Input2ScaleLowScl2	nvo(node)Input2ScaleLowScl2
INPUT 2 SCALE HIGH SCH2	nvi(node)Input2ScaleHighSch2	nvo(node)Input2ScaleHighSch2
OFFSET INPUT 2 OFF2	nvi(node)OffsetInput2Off2	nvo(node)OffsetInput2Off2
OFFSET INPUT 3 OFF3	nvi(node)OffsetInput3Off3	nvo(node)OffsetInput3Off3
SETPOINT LIMIT SCALE LOW SPL	nvi(node)SpLimitScaleLowSpl	nvo(node)SpLimitScaleLowSpl
SETPOINT LIMIT SCALE HIGH SPH	nvi(node)SpLimitScaleHighSph	nvo(node)SpLimitScaleHighSph
INPUT 1 FAULT	not writable	nvo(node)Input1Fault
INPUT 2 FAULT	not writable	nvo(node)Input2Fault
INPUT 3 FAULT	not writable	nvo(node)Input3Fault
STAGE MODE	not writable	nvo(node)StageMode
MANUAL OPERATION	not writable	nvo(node)ManualOperation
BINARY INPUT 1	not writable	nvo(node)BinaryInput1
BINARY INPUT 2	not writable	nvo(node)BinaryInput2
STAT ACTIVE	not writable	nvo(node)StatActive
UP ACTIVE	not writable	nvo(node)UpActive
DOWN ACTIVE	not writable	nvo(node)DownActive
K6 ACTIVE	not writable	nvo(node)K6Active

(node) = Modbus address. Example: Point for device with Modbus address 1 would be nvo1xxx.

Point List BACnet and Metasys N2 - TS Series DA/ST Master

Point Name	BACnet Obj Type	BACnet Obj ID	N2 Data Type	N2 Point Address
P1 HOA	AI	1	AI	1
P2 HOA	AI	2	AI	2
P3 HOA	AI	3	AI	3
P4 HOA	AI	4	AI	4
P5 HOA	AI	5	AI	5
P6 HOA	AI	6	AI	6
DA TANK PRESSURE	AI	7	AI	7
STEAM VALVE POSITION	AI	8	AI	8
DA SETPOINT	AI	9	AI	9
DA WATER LEVEL	AI	10	AI	10
INLET VALVE POSITION	AI	11	AI	11
DA WL SETPOINT	AI	12	AI	12
P1 RUN TIME	AI	13	AI	13
P2 RUN TIME	AI	14	AI	14
P3 RUN TIME	AI	15	AI	15
P4 RUN TIME	AI	16	AI	16
P5 RUN TIME	AI	17	AI	17
P6 RUN TIME	AI	18	AI	18
DA WATER TEMP	AI	19	AI	19
ST WATER TEMP	AI	20	AI	20
RTD 3	AI	21	AI	21
RTD 4	AI	22	AI	22
ANALOG INPUT 1	AI	23	AI	23
ANALOG INPUT 2	AI	24	AI	24
ANALOG INPUT 3	AI	25	AI	25
ANALOG INPUT 4	AI	26	AI	26
ANALOG INPUT 5	AI	27	AI	27
ANALOG INPUT 6	AI	28	AI	28
ANALOG INPUT 7	AI	29	AI	29
ANALOG INPUT 8	AI	30	AI	30
ANALOG OUTPUT 1	AI	31	AI	31
ANALOG OUTPUT 2	AI	32	AI	32
ANALOG OUTPUT 3	AI	33	AI	33
ANALOG OUTPUT 4	AI	34	AI	34
P1 PROVEN	BI	1	DI	1
P2 PROVEN	BI	2	DI	2
P3 PROVEN	BI	3	DI	3
P4 PROVEN	BI	4	DI	4
P5 PROVEN	BI	5	DI	5
P6 PROVEN	BI	6	DI	6
DA HIGH WATER	BI	7	DI	7
DA LOW WATER	BI	8	DI	8
DA LOW LOW WATER	BI	9	DI	9
ST HIGH WATER	BI	10	DI	10
ST LOW WATER	BI	11	DI	11

Point List BACnet and Metasys N2 - TS Series DA/ST Master (cont)

Point Name	BACnet Obj Type	BACnet Obj ID	N2 Data Type	N2 Point Address
ST LOW LOW WATER	BI	12	DI	12
P1 FAIL	BI	13	DI	13
P2 FAIL	BI	14	DI	14
P3 FAIL	BI	15	DI	15
P4 FAIL	BI	16	DI	16
P5 FAIL	BI	17	DI	17
P6 FAIL	BI	18	DI	18

Point List LonWorks - TS Series DA/ST Master

Point Name	LonWorks Input	LonWorks Output
P1 HOA	not writable	nvo(node)P1Hoa
P2 HOA	not writable	nvo(node)P2Hoa
P3 HOA	not writable	nvo(node)P3Hoa
P4 HOA	not writable	nvo(node)P4Hoa
P5 HOA	not writable	nvo(node)P5Hoa
P6 HOA	not writable	nvo(node)P6Hoa
DA TANK PRESSURE	not writable	nvo(node)DaTankPressure
STEAM VALVE POSITION	not writable	nvo(node)SteamValvePosition
DA SETPOINT	not writable	nvo(node)DaSetpoint
DA WATER LEVEL	not writable	nvo(node)DaWaterLevel
INLET VALVE POSITION	not writable	nvo(node)InletValvePosition
DA WL SETPOINT	not writable	nvo(node)DaWlSetpoint
P1 RUN TIME	not writable	nvo(node)P1RunTime
P2 RUN TIME	not writable	nvo(node)P2RunTime
P3 RUN TIME	not writable	nvo(node)P3RunTime
P4 RUN TIME	not writable	nvo(node)P4RunTime
P5 RUN TIME	not writable	nvo(node)P5RunTime
P6 RUN TIME	not writable	nvo(node)P6RunTime
DA WATER TEMP	not writable	nvo(node)DaWaterTemp
ST WATER TEMP	not writable	nvo(node)StWaterTemp
RTD 3	not writable	nvo(node)Rtd3
RTD 4	not writable	nvo(node)Rtd4
ANALOG INPUT 1	not writable	nvo(node)AnalogInput1
ANALOG INPUT 2	not writable	nvo(node)AnalogInput2
ANALOG INPUT 3	not writable	nvo(node)AnalogInput3
ANALOG INPUT 4	not writable	nvo(node)AnalogInput4
ANALOG INPUT 5	not writable	nvo(node)AnalogInput5
ANALOG INPUT 6	not writable	nvo(node)AnalogInput6
ANALOG INPUT 7	not writable	nvo(node)AnalogInput7
ANALOG INPUT 8	not writable	nvo(node)AnalogInput8
ANALOG OUTPUT 1	not writable	nvo(node)AnalogOutput1
ANALOG OUTPUT 2	not writable	nvo(node)AnalogOutput2
ANALOG OUTPUT 3	not writable	nvo(node)AnalogOutput3
ANALOG OUTPUT 4	not writable	nvo(node)AnalogOutput4
P1 PROVEN	not writable	nvo(node)P1Proven
P2 PROVEN	not writable	nvo(node)P2Proven
P3 PROVEN	not writable	nvo(node)P3Proven
P4 PROVEN	not writable	nvo(node)P4Proven
P5 PROVEN	not writable	nvo(node)P5Proven
P6 PROVEN	not writable	nvo(node)P6Proven
DA HIGH WATER	not writable	nvo(node)DaHighWater
DA LOW WATER	not writable	nvo(node)DaLowWater
DA LOW LOW WATER	not writable	nvo(node)DaLowLowWater
ST HIGH WATER	not writable	nvo(node)StHighWater
ST LOW WATER	not writable	nvo(node)StLowWater

Point List LonWorks - TS Series DA/ST Master (continued)

Point Name	LonWorks Input	LonWorks Output
ST LOW LOW WATER	not writable	nvo(node)StLowLowWater
P1 FAIL	not writable	nvo(node)P1Fail
P2 FAIL	not writable	nvo(node)P2Fail
P3 FAIL	not writable	nvo(node)P3Fail
P4 FAIL	not writable	nvo(node)P4Fail
P5 FAIL	not writable	nvo(node)P5Fail
P6 FAIL	not writable	nvo(node)P6Fail

(node) = Modbus address. Example: Point for device with Modbus address 1 would be nvo1xxx.

Point List BACnet and Metasys N2 - TS Series Touchscreen Kit

Point Name	BACnet Obj Type	BACnet Obj ID	N2 Data Type	N2 Point Address
LMV PHASE	AI	1	AI	1
LMV FUEL ACTUATOR	AI	2	AI	2
LMV GAS ACTUATOR	AI	3	AI	3
LMV OIL ACTUATOR	AI	4	AI	4
LMV AIR ACTUATOR	AI	5	AI	5
LMV AUX1 ACTUATOR	AI	6	AI	6
LMV AUX2 ACTUATOR	AI	7	AI	7
LMV AUX3 ACTUATOR	AI	8	AI	8
LMV VSD OUTPUT	AI	9	AI	9
LMV CURR FUEL	AI	10	AI	10
LMV CURR OUTPUT	AI	11	AI	11
LMV CURR SETPOINT	AI	12	AI	12
LMV ACTUAL VALUE	AI	13	AI	13
LMV FLAME SIGNAL	AI	14	AI	14
LMV FUEL THROUGHPUT	AI	15	AI	15
LMV CURR O ₂	AI	16	AI	16
LMV GAS UNIT	AI	17	AI	17
LMV OIL UNIT	AI	18	AI	18
LMV TEMP UNIT	AI	19	AI	19
LMV PRESSURE UNIT	AI	20	AI	20
LMV SENSOR SELECTION	AI	21	AI	21
LMV STARTUP COUNTER	AI	22	AI	22
LMV HOUR COUNTER	AI	23	AI	23
LMV CURR ERR CODE	AI	24	AI	24
LMV CURR DIAGNOSTIC CODE	AI	25	AI	25
LMV CURR ERR CLASS	AI	26	AI	26
LMV CURR ERR PHASE	AI	27	AI	27
LMV TEMP LIMIT OFF THRESHOLD	AI	28	AI	28
LMV SUPPLY AIR TEMP	AI	29	AI	29
LMV FLUE GAS TEMP	AI	30	AI	30
LMV COMBUSTION EFFICIENCY	AI	31	AI	31
LMV CURR CO ₂	AI	32	AI	32
LMV CURR EXCESS AIR	AI	33	AI	33
LMV INPUT WORD	AI	34	AI	34
LMV OUTPUT WORD	AI	35	AI	35
LMV PROGRAM STOP	AV	36	AO	36
LMV LOAD CNTRL MODE	AV	37	AO	37
LMV MANUAL/AUTOMATIC	AI	38	AI	38
LMV MODBUS LOCAL/REMOTE	AV	39	AO	39
LMV MODBUS WATCHDOG	AV	40	AO	40
LMV MODBUS OPERATING MODE	AV	41	AO	41
LMV MODBUS SETPOINT W3	AV	42	AO	42
LMV MODBUS OUTPUT	AV	43	AO	43
LMV MODBUS FUEL SELECTION	AV	44	AO	44
LMV SETPOINT W1	AV	45	AO	45

Point List BACnet and Metasys N2 - TS Series Touchscreen Kit (cont)

Point Name	BACnet Obj Type	BACnet Obj ID	N2 Data Type	N2 Point Address
LMV SETPOINT W2	AV	46	AO	46
LMV WEEKDAY	AV	47	AO	47
LMV YEAR 2-DIGIT	AV	48	AO	48
LMV MONTH	AI	49	AI	49
LMV DAY	AI	50	AI	50
LMV HOUR	AV	51	AO	51
LMV MINUTE	AI	52	AI	52
LMV SECOND	AI	53	AI	53
LMV HOURS RUN GAS RESET	AV	54	AO	54
LMV HOURS RUN OIL S1 RESET	AV	55	AO	55
LMV HOURS RUN OIL S2 RESET	AV	56	AO	56
LMV HOURS RUN OIL S3 RESET	AV	57	AO	57
LMV HOURS RUN TOTAL RESET	AV	58	AO	58
LMV HOURS RUN TOTAL FIXED	AI	59	AI	59
LMV HOURS CONNECT TO POWER	AI	60	AI	60
LMV STARTUPS GAS RESET	AV	61	AO	61
LMV STARTUPS OIL RESET	AV	62	AO	62
LMV STARTUPS TOTAL RESET	AV	63	AO	63
LMV STARTUPS TOTAL FIXED	AI	64	AI	64
LMV TOTAL VOLUME GAS/FUELO	AV	65	AO	65
LMV TOTAL VOLUME OIL/FUEL1	AV	66	AO	66
LMV NUMBER OF LOCKOUTS	AI	67	AI	67
LMV EXTRA TEMP SENSOR	AI	68	AI	68
LMV AZL5 PARAMETER SET CODE	AI	69	AI	69
LMV AZL5 PARAMETER SET VER	AI	70	AI	70
LMV AZL5 ID DATE YEAR 2-DIGIT	AI	71	AI	71
LMV AZL5 ID DATE MONTH	AI	72	AI	72
LMV AZL5 ID DATE DAY	AI	73	AI	73
LMV AZL5 ID NUMBER	AI	74	AI	74
LMV BC PARAMETER SET CODE	AI	75	AI	75
LMV BC PARAMETER SET VER	AI	76	AI	76
LMV BC ID DATE YEAR 2-DIGIT	AI	77	AI	77
LMV BC ID DATE MONTH	AI	78	AI	78
LMV BURNER CNTRL ID DATE DAY	AI	79	AI	79
LMV BURNER CNTRL ID NUMBER	AI	80	AI	80
LMV SOFTWARE VERSION AZL	AI	81	AI	81
LMV SW VER BURNER CNTRL	AI	82	AI	82
LMV SW VER LOAD CNTRL	AI	83	AI	83
LMV MINIMUM OUTPUT GAS	AI	84	AI	84
LMV MAXIMUM OUTPUT GAS	AI	85	AI	85
LMV MINIMUM OUTPUT OIL	AI	86	AI	86
LMV MAXIMUM OUTPUT OIL	AI	87	AI	87
LMV LOAD LIMIT MODULATING	AV	88	AO	88
LMV LOAD LIMIT STAGING	AV	89	AO	89
LMV TEMP LIMIT ON THRESHOLD	AI	90	AI	90

Point List BACnet and Metasys N2 - TS Series Touchscreen Kit (cont)

Point Name	BACnet Obj Type	BACnet Obj ID	N2 Data Type	N2 Point Address
LMV RANGE TEMP SENSOR	AI	91	AI	91
LMV ADAPTION ACTIVE	AI	92	AI	92
LMV ADAPTION STATE	AI	93	AI	93
LMV START ADAPTION	AV	94	AO	94
LMV ADAPTION OUTPUT	AV	95	AO	95
LMV P-VALUE	AV	96	AO	96
LMV I-VALUE	AV	97	AO	97
LMV D-VALUE	AV	98	AO	98
LMV LOCKOUT ERR CODE CURR	AI	99	AI	99
LMV LOCKOUT DIAG CODE CURR	AI	100	AI	100
LMV LOCKOUT ERR CLASS CURR	AI	101	AI	101
LMV LOCKOUT ERR PHASE CURR	AI	102	AI	102
LMV LOCKOUT FUEL CURR	AI	103	AI	103
LMV LOCKOUT OUTPUT CURR	AI	104	AI	104
LMV LOCKOUT YEAR 2-DIG CURR	AI	105	AI	105
LMV LOCKOUT MONTH CURR	AI	106	AI	106
LMV LOCKOUT DAY CURR	AI	107	AI	107
LMV LOCKOUT HOUR CURR	AI	108	AI	108
LMV LOCKOUT MINUTE CURR	AI	109	AI	109
LMV LOCKOUT SECOND CURR	AI	110	AI	110
LMV LOCKOUT STARTUPS CURR	AI	111	AI	111
LMV LOCKOUT HOURS CURR	AI	112	AI	112
LMV ERR ERR CODE CURR	AI	113	AI	113
LMV ERR DIAG CODE CURR	AI	114	AI	114
LMV ERR ERR CLASS CURR	AI	115	AI	115
LMV ERR ERR PHASE CURR	AI	116	AI	116
LMV ERR FUEL CURR	AI	117	AI	117
LMV ERR OUTPUT CURR	AI	118	AI	118
LMV ERR STARTUPS CURR	AI	119	AI	119
EQUIPMENT FAULTS	AI	120	AI	120
RWF LC INPUT WORD	AI	121	AI	121
RWF LC OUTPUT WORD	AI	122	AI	122
RWF LC E1	AI	123	AI	123
RWF LC E2	AI	124	AI	124
RWF LC E3	AI	125	AI	125
RWF LC WR CURR SP	AI	126	AI	126
RWF LC SP1	AI	127	AI	127
RWF LC SP2	AI	128	AI	128
RWF LC AL ALARM SP	AI	129	AI	129
RWF LC PB1 PROPORTIONAL	AI	130	AI	130
RWF LC DT DERIVATIVE	AI	131	AI	131
RWF LC RT INTEGRAL	AI	132	AI	132
RWF LC HYS1	AI	133	AI	133
RWF LC HYS3	AI	134	AI	134
RWF LC DTT WATCHDOG	AI	135	AI	135

Point List BACnet and Metasys N2 - TS Series Touchscreen Kit (cont)

Point Name	BACnet Obj Type	BACnet Obj ID	N2 Data Type	N2 Point Address
RWF LC E3 UNFILTERED	AI	136	AI	136
RWF LC REM REMOTE OPERATION	AI	137	AI	137
RWF LC ROFF REMOTE OFF	AI	138	AI	138
RWF LC RK1 REM BURNER CNTRL	AI	139	AI	139
RWF LC RK6 REMOTE K6 CNTRL	AI	140	AI	140
RWF LC SPR REMOTE SETPOINT	AI	141	AI	141
RWF LC RY REMOTE OUTPUT	AI	142	AI	142
RWF LC Y OUTPUT	AI	143	AI	143
RWF FW INPUT WORD	AI	144	AI	144
RWF FW OUTPUT WORD	AI	145	AI	145
RWF FW LEVEL PERCENT	AI	146	AI	146
RWF FW SETPOINT PERCENT	AI	147	AI	147
RWF FW E1	AI	148	AI	148
RWF FW E2	AI	149	AI	149
RWF FW E3	AI	150	AI	150
RWF FW WR CURR SP	AI	151	AI	151
RWF FW SP1	AI	152	AI	152
RWF FW SP2	AI	153	AI	153
RWF FW Y	AI	154	AI	154
RWF EX1 INPUT WORD	AI	155	AI	155
RWF EX1 OUTPUT WORD	AI	156	AI	156
RWF EX1 E1	AI	157	AI	157
RWF EX1 E2	AI	158	AI	158
RWF EX1 E3	AI	159	AI	159
RWF EX1 WR CURR SP	AI	160	AI	160
RWF EX1 SP1	AI	161	AI	161
RWF EX1 SP2	AI	162	AI	162
RWF EX1 AL ALARM SP	AI	163	AI	163
RWF EX1 HYS1	AI	164	AI	164
RWF EX1 HYS3	AI	165	AI	165
RWF EX1 Y OUTPUT	AI	166	AI	166
RWF EX2 INPUT WORD	AI	167	AI	167
RWF EX2 OUTPUT WORD	AI	168	AI	168
RWF EX2 E1	AI	169	AI	169
RWF EX2 E2	AI	170	AI	170
RWF EX2 E3	AI	171	AI	171
RWF EX2 WR CURR SP	AI	172	AI	172
RWF EX2 SP1	AI	173	AI	173
RWF EX2 SP2	AI	174	AI	174
RWF EX2 AL ALARM SP	AI	175	AI	175
RWF EX2 HYS1	AI	176	AI	176
RWF EX2 HYS3	AI	177	AI	177
RWF EX2 Y OUTPUT	AI	178	AI	178
EA DIGITAL INPUT WORD	AI	179	AI	179
EA STATUS WORD	AI	180	AI	180

Point List BACnet and Metasys N2 - TS Series Touchscreen Kit (cont)

Point Name	BACnet Obj Type	BACnet Obj ID	N2 Data Type	N2 Point Address
EA ALARM WORD	AI	181	AI	181
EA RTD 1	AI	182	AI	182
EA RTD 2	AI	183	AI	183
EA RTD 3	AI	184	AI	184
EA RTD 4	AI	185	AI	185
EA ANALOG INPUT 1	AI	186	AI	186
EA ANALOG INPUT 2	AI	187	AI	187
EA ANALOG INPUT 3	AI	188	AI	188
EA ANALOG INPUT 4	AI	189	AI	189
EA ECONOMIZER WATER IN	AI	190	AI	190
EA ECONOMIZER WATER OUT	AI	191	AI	191
EA ECONOMIZER STACK IN	AI	192	AI	192
EA ECONOMIZER STACK OUT	AI	193	AI	193
EA DRAFT FEEDBACK	AI	194	AI	194
EA DRAFT ALARM	AI	195	AI	195
EA DRAFT ALARM CODE	AI	196	AI	196
EA DRAFT ALARM PHASE	AI	197	AI	197
EA DRAFT DRIVE WORD	AI	198	AI	198
EA DRAFT SWITCH	AI	199	AI	199
EA DRAFT SENSOR	AI	200	AI	200
EA LC INPUT WORD	AI	201	AI	201
EA LC OUTPUT WORD	AI	202	AI	202
EA LC E1	AI	203	AI	203
EA LC E3	AI	204	AI	204
EA LC WR CURR SP	AI	205	AI	205
EA LC SP1	AI	206	AI	206
EA LC AL ALARM SP	AI	207	AI	207
EA LC PB1 PROPORTIONAL	AI	208	AI	208
EA LC DT DERIVATIVE	AI	209	AI	209
EA LC RT INTEGRAL	AI	210	AI	210
EA LC HYS1	AI	211	AI	211
EA LC HYS3	AI	212	AI	212
EA LC REM REMOTE OPERATION	AI	213	AI	213
EA LC ROFF REMOTE OFF	AI	214	AI	214
EA LC RK1 REM BURNER CNTRL	AI	215	AI	215
EA LC SPR REMOTE SETPOINT	AI	216	AI	216
EA LC RY REMOTE OUTPUT	AI	217	AI	217
EA LC Y OUTPUT	AI	218	AI	218
VSD FREQ REF PERCENT	AI	219	AI	219
VSD OUTPUT FREQ PERCENT	AI	220	AI	220
VSD OUTPUT VOLTAGE	AI	221	AI	221
VSD DC BUS VOLTAGE	AI	222	AI	222
VSD STATUS WORD	AI	223	AI	223
VSD OUTPUT RPM	AI	224	AI	224
VSD OUTPUT CURR	AI	225	AI	225

Point List BACnet and Metasys N2 - TS Series Touchscreen Kit (cont)

Point Name	BACnet Obj Type	BACnet Obj ID	N2 Data Type	N2 Point Address
VSD FREQ REFERENCE HERTZ	AI	226	AI	226
VSD OUTPUT FREQ HERTZ	AI	227	AI	227
VSD ALARM CODE	AI	228	AI	228
VSD FAULT CODE	AI	229	AI	229
VSD DC BUS PEAK	AI	230	AI	230
VSD OUTPUT CURR PEAK	AI	231	AI	231
VSD OUTPUT POWER	AI	232	AI	232
VSD TOTALIZED POWER	AI	233	AI	233
LMV CNTRLLER SWITCH	BI	1	DI	1
LMV FAN CONTACTOR	BI	2	DI	2
LMV OIL SELECTED	BI	3	DI	3
LMV GAS SELECTED	BI	4	DI	4
LMV OIL PRESS SW MAX	BI	5	DI	5
LMV OIL PRESS SW MIN	BI	6	DI	6
LMV VALVE PROVING SW	BI	7	DI	7
LMV SAFETY LOOP	BI	8	DI	8
LMV GAS PRESS SW MIN	BI	9	DI	9
LMV GAS PRESS SW MAX	BI	10	DI	10
LMV AIR PRESSURE SW	BI	11	DI	11
LMV START RELEASE OIL	BI	12	DI	12
LMV HEAVY OIL START	BI	13	DI	13
LMV ALARM	BI	14	DI	14
LMV IGNITION	BI	15	DI	15
LMV START SIGNAL	BI	16	DI	16
LMV FAN OUTPUT	BI	17	DI	17
LMV OIL PUMP	BI	18	DI	18
LMV FUEL VALVE SV OIL	BI	19	DI	19
LMV FUEL VALVE V1 OIL	BI	20	DI	20
LMV FUEL VALVE V2 OIL	BI	21	DI	21
LMV FUEL VALVE V3 OIL	BI	22	DI	22
LMV FUEL VALVE SV GAS	BI	23	DI	23
LMV FUEL VALVE V1 GAS	BI	24	DI	24
LMV FUEL VALVE V2 GAS	BI	25	DI	25
LMV FUEL VALVE PV GAS	BI	26	DI	26
EQUIPMENT FAULT LMV5	BI	27	DI	27
EQUIPMENT FAULT LMV3	BI	28	DI	28
EQUIPMENT FAULT RWF10 LC	BI	29	DI	29
EQUIPMENT FAULT RWF40 LC	BI	30	DI	30
EQUIPMENT FAULT RWF55 LC	BI	31	DI	31
EQUIPMENT FAULT RWF40 FW	BI	32	DI	32
EQUIPMENT FAULT RWF55 FW	BI	33	DI	33
EQUIPMENT FAULT EA	BI	34	DI	34
EQUIPMENT FAULT VSD	BI	35	DI	35
RWF LC INPUT 1 FAULT	BI	36	DI	36
RWF LC INPUT 2 FAULT	BI	37	DI	37

Point List BACnet and Metasys N2 - TS Series Touchscreen Kit (cont)

Point Name	BACnet Obj Type	BACnet Obj ID	N2 Data Type	N2 Point Address
RWF LC INPUT 3 FAULT	BI	38	DI	38
RWF LC STAGE MODE	BI	39	DI	39
RWF LC MANUAL OPERATION	BI	40	DI	40
RWF LC BINARY INPUT 1	BI	41	DI	41
RWF LC BINARY INPUT 2	BI	42	DI	42
RWF LC STAT ACTIVE	BI	43	DI	43
RWF LC UP ACTIVE	BI	44	DI	44
RWF LC DOWN ACTIVE	BI	45	DI	45
RWF LC K6 ACTIVE	BI	46	DI	46
RWF FW INPUT 1 FAULT	BI	47	DI	47
RWF FW INPUT 2 FAULT	BI	48	DI	48
RWF FW INPUT 3 FAULT	BI	49	DI	49
RWF FW STAGE MODE	BI	50	DI	50
RWF FW MANUAL OPERATION	BI	51	DI	51
RWF FW BINARY INPUT 1	BI	52	DI	52
RWF FW BINARY INPUT 2	BI	53	DI	53
RWF FW STAT ACTIVE	BI	54	DI	54
RWF FW UP ACTIVE	BI	55	DI	55
RWF FW DOWN ACTIVE	BI	56	DI	56
RWF FW K6 ACTIVE	BI	57	DI	57
RWF EX1 INPUT 1 FAULT	BI	58	DI	58
RWF EX1 INPUT 2 FAULT	BI	59	DI	59
RWF EX1 INPUT 3 FAULT	BI	60	DI	60
RWF EX1 STAGE MODE	BI	61	DI	61
RWF EX1 MANUAL OPERATION	BI	62	DI	62
RWF EX1 BINARY INPUT 1	BI	63	DI	63
RWF EX1 BINARY INPUT 2	BI	64	DI	64
RWF EX1 STAT ACTIVE	BI	65	DI	65
RWF EX1 UP ACTIVE	BI	66	DI	66
RWF EX1 DOWN ACTIVE	BI	67	DI	67
RWF EX1 K6 ACTIVE	BI	68	DI	68
RWF EX2 INPUT 1 FAULT	BI	69	DI	69
RWF EX2 INPUT 2 FAULT	BI	70	DI	70
RWF EX2 INPUT 3 FAULT	BI	71	DI	71
RWF EX2 STAGE MODE	BI	72	DI	72
RWF EX2 MANUAL OPERATION	BI	73	DI	73
RWF EX2 BINARY INPUT 1	BI	74	DI	74
RWF EX2 BINARY INPUT 2	BI	75	DI	75
RWF EX2 STAT ACTIVE	BI	76	DI	76
RWF EX2 UP ACTIVE	BI	77	DI	77
RWF EX2 DOWN ACTIVE	BI	78	DI	78
RWF EX2 K6 ACTIVE	BI	79	DI	79
EA INPUT 1	BI	80	DI	80
EA INPUT 2	BI	81	DI	81
EA INPUT 3	BI	82	DI	82

Point List BACnet and Metasys N2 - TS Series Touchscreen Kit (cont)

Point Name	BACnet Obj Type	BACnet Obj ID	N2 Data Type	N2 Point Address
EA INPUT 4	BI	83	DI	83
EA INPUT 5	BI	84	DI	84
EA INPUT 6	BI	85	DI	85
EA INPUT 7	BI	86	DI	86
EA INPUT 8	BI	87	DI	87
EA INPUT 9	BI	88	DI	88
EA INPUT 10	BI	89	DI	89
EA INPUT 11	BI	90	DI	90
EA INPUT 12	BI	91	DI	91
EA INPUT 13	BI	92	DI	92
EA PUMP PROVEN	BI	93	DI	93
EA PUMP ALARM	BI	94	DI	94
EA AI1 HIGH ALARM	BI	95	DI	95
EA AI1 LOW ALARM	BI	96	DI	96
EA AI2 HIGH ALARM	BI	97	DI	97
EA AI2 LOW ALARM	BI	98	DI	98
EA AI3 HIGH ALARM	BI	99	DI	99
EA AI3 LOW ALARM	BI	100	DI	100
EA AI4 HIGH ALARM	BI	101	DI	101
EA AI4 LOW ALARM	BI	102	DI	102
EA AO1 HIGH ALARM	BI	103	DI	103
EA AO1 LOW ALARM	BI	104	DI	104
EA AO2 HIGH ALARM	BI	105	DI	105
EA AO2 LOW ALARM	BI	106	DI	106
EA ALARM INPUT 1	BI	107	DI	107
EA ALARM INPUT 2	BI	108	DI	108
EA ALARM INPUT 3	BI	109	DI	109
EA ALARM INPUT 4	BI	110	DI	110
EA ALARM INPUT 5	BI	111	DI	111
EA ALARM INPUT 6	BI	112	DI	112
EA ALARM INPUT 7	BI	113	DI	113
EA ALARM INPUT 8	BI	114	DI	114
EA ALARM INPUT 9	BI	115	DI	115
EA ALARM INPUT 10	BI	116	DI	116
EA ALARM INPUT 11	BI	117	DI	117
EA ALARM INPUT 12	BI	118	DI	118
EA ALARM INPUT 13	BI	119	DI	119
EA DRAFT OPEN POSITION	BI	120	DI	120
EA DRAFT CLOSE POSITION	BI	121	DI	121
EA DRAFT START POSITION	BI	122	DI	122
EA DRAFT MODULATE	BI	123	DI	123
EA LC STAT ACTIVE	BI	124	DI	124
EA LC K6 ACTIVE	BI	125	DI	125
VSD RUNNING	BI	126	DI	126
VSD ZERO SPEED	BI	127	DI	127

Point List BACnet and Metasys N2 - TS Series Touchscreen Kit (cont)

Point Name	BACnet Obj Type	BACnet Obj ID	N2 Data Type	N2 Point Address
VSD SPEED AGREE	BI	128	DI	128
VSD READY STATE	BI	129	DI	129
VSD ALARM STATE	BI	130	DI	130
VSD FAULT STATE	BI	131	DI	131

Point List LonWorks - TS Series Touchscreen Kit

Point Name	LonWorks Input	LonWorks Output
LMV PHASE	not writable	nvo(boiler)LmvPhase
LMV FUEL ACTUATOR	not writable	nvo(boiler)LmvFuelActuator
LMV GAS ACTUATOR	not writable	nvo(boiler)LmvGasActuator
LMV OIL ACTUATOR	not writable	nvo(boiler)LmvOilActuator
LMV AIR ACTUATOR	not writable	nvo(boiler)LmvAirActuator
LMV AUX1 ACTUATOR	not writable	nvo(boiler)LmvAux1Actuator
LMV AUX2 ACTUATOR	not writable	nvo(boiler)LmvAux2Actuator
LMV AUX3 ACTUATOR	not writable	nvo(boiler)LmvAux3Actuator
LMV VSD OUTPUT	not writable	nvo(boiler)LmvVsdOutput
LMV CURR FUEL	not writable	nvo(boiler)LmvCurrFuel
LMV CURR OUTPUT	not writable	nvo(boiler)LmvCurrOutput
LMV CURR SETPOINT	not writable	nvo(boiler)LmvCurrSetpoint
LMV ACTUAL VALUE	not writable	nvo(boiler)LmvActualValue
LMV FLAME SIGNAL	not writable	nvo(boiler)LmvFlameSignal
LMV FUEL THROUGHPUT	not writable	nvo(boiler)LmvFuelThroughput
LMV CURR O ₂	not writable	nvo(boiler)LmvCurrO2
LMV GAS UNIT	not writable	nvo(boiler)LmvGasUnit
LMV OIL UNIT	not writable	nvo(boiler)LmvOilUnit
LMV TEMP UNIT	not writable	nvo(boiler)LmvTempUnit
LMV PRESSURE UNIT	not writable	nvo(boiler)LmvPressureUnit
LMV SENSOR SELECTION	not writable	nvo(boiler)LmvSensorSel
LMV STARTUP COUNTER	not writable	nvo(boiler)LmvStartupCounter
LMV HOUR COUNTER	not writable	nvo(boiler)LmvHourCounter
LMV CURR ERR CODE	not writable	nvo(boiler)LmvCurrErrCode
LMV CURR DIAGNOSTIC CODE	not writable	nvo(boiler)LmvCurrDiagCode
LMV CURR ERR CLASS	not writable	nvo(boiler)LmvCurrErrClass
LMV CURR ERR PHASE	not writable	nvo(boiler)LmvCurrErrPhase
LMV TEMP LIMIT OFF THRESHOLD	not writable	nvo(boiler)LmvTempLimOff
LMV SUPPLY AIR TEMP	not writable	nvo(boiler)LmvSupplyAirTemp
LMV FLUE GAS TEMP	not writable	nvo(boiler)LmvFlueGasTemp
LMV COMBUSTION EFFICIENCY	not writable	nvo(boiler)LmvCombEff
LMV CURR CO ₂	not writable	nvo(boiler)LmvCurrCO2
LMV CURR EXCESS AIR	not writable	nvo(boiler)LmvCurrExAir
LMV INPUT WORD	not writable	nvo(boiler)LmvInputWord
LMV OUTPUT WORD	not writable	nvo(boiler)LmvOutputWord
LMV PROGRAM STOP	nvi(boiler)LmvProgramStop	nvo(boiler)LmvProgramStop
LMV LOAD CNTRL MODE	nvi(boiler)LmvLoadCntlMode	nvo(boiler)LmvLoadCntlMode
LMV MANUAL/AUTOMATIC	not writable	nvo(boiler)LmvManAuto
LMV MODBUS LOCAL/REMOTE	nvi(boiler)LmvModbusLocRem	nvo(boiler)LmvModbusLocRem
LMV MODBUS WATCHDOG	nvi(boiler)LmvModbusWatchdog	nvo(boiler)LmvModbusWatchdog
LMV MODBUS OPERATING MODE	nvi(boiler)LmvModbusOpMode	nvo(boiler)LmvModbusOpMode
LMV MODBUS SETPOINT W3	nvi(boiler)LmvModbusSpW3	nvo(boiler)LmvModbusSpW3
LMV MODBUS OUTPUT	nvi(boiler)LmvModbusOutput	nvo(boiler)LmvModbusOutput
LMV MODBUS FUEL SELECTION	nvi(boiler)LmvModbusFuelSel	nvo(boiler)LmvModbusFuelSel
LMV SETPOINT W1	nvi(boiler)LmvSetpointW1	nvo(boiler)LmvSetpointW1

Point List LonWorks - TS Series Touchscreen Kit (cont)

Point Name	LonWorks Input	LonWorks Output
LMV SETPOINT W2	nvi(boiler)LmvSetpointW2	nvo(boiler)LmvSetpointW2
LMV WEEKDAY	not writable	nvo(boiler)LmvWeekday
LMV YEAR 2-DIGIT	not writable	nvo(boiler)LmvDateTime
LMV MONTH	not writable	" "
LMV DAY	not writable	" "
LMV HOUR	not writable	" "
LMV MINUTE	not writable	" "
LMV SECOND	not writable	" "
LMV HOURS RUN GAS RESET	nvi(boiler)LmvHrsRunGasRst	nvo(boiler)LmvHrsRunGasRst
LMV HOURS RUN OIL S1 RESET	nvi(boiler)LmvHrsRunOilS1Rst	nvo(boiler)LmvHrsRunOilS1Rst
LMV HOURS RUN OIL S2 RESET	nvi(boiler)LmvHrsRunOilS2Rst	nvo(boiler)LmvHrsRunOilS2Rst
LMV HOURS RUN OIL S3 RESET	nvi(boiler)LmvHrsRunOilS3Rst	nvo(boiler)LmvHrsRunOilS3Rst
LMV HOURS RUN TOTAL RESET	nvi(boiler)LmvHrsRunTotRst	nvo(boiler)LmvHrsRunTotRst
LMV HOURS RUN TOTAL FIXED	not writable	nvo(boiler)LmvHrsRunTotFixed
LMV HOURS CONNECT TO POWER	not writable	nvo(boiler)LmvHrsConnToPower
LMV STARTUPS GAS RESET	nvi(boiler)LmvStartsGasRst	nvo(boiler)LmvStartsGasRst
LMV STARTUPS OIL RESET	nvi(boiler)LmvStartsOilRst	nvo(boiler)LmvStartsOilRst
LMV STARTUPS TOTAL RESET	nvi(boiler)LmvStartsTotRst	nvo(boiler)LmvStartsTotRst
LMV STARTUPS TOTAL FIXED	not writable	nvo(boiler)LmvStartsTotFixed
LMV TOTAL VOLUME GAS/FUELO	nvi(boiler)LmvTotVolGasF0	nvo(boiler)LmvTotVolGasF0
LMV TOTAL VOLUME OIL/FUEL1	nvi(boiler)LmvTotVolOilF1	nvo(boiler)LmvTotVolOilF1
LMV NUMBER OF LOCKOUTS	not writable	nvo(boiler)LmvNumOfLockouts
LMV EXTRA TEMP SENSOR	not writable	nvo(boiler)LmvExtraTempSens
LMV AZL5 PARAMETER SET CODE	not writable	nvo(boiler)LmvAzl5PrmSetCode
LMV AZL5 PARAMETER SET VER	not writable	nvo(boiler)LmvAzl5PrmSetVer
LMV AZL5 ID DATE YEAR 2-DIGIT	not writable	nvo(boiler)LmvAzl5IdDate
LMV AZL5 ID DATE MONTH	not writable	" "
LMV AZL5 ID DATE DAY	not writable	" "
LMV AZL5 ID NUMBER	not writable	nvo(boiler)LmvAzl5IdNumber
LMV BC PARAMETER SET CODE	not writable	nvo(boiler)LmvBcParamSetCode
LMV BC PARAMETER SET VER	not writable	nvo(boiler)LmvBcParamSetVer
LMV BC ID DATE YEAR 2-DIGIT	not writable	nvo(boiler)LmvBcIdDate
LMV BC ID DATE MONTH	not writable	" "
LMV BURNER CNTRL ID DATE DAY	not writable	" "
LMV BURNER CNTRL ID NUMBER	not writable	nvo(boiler)LmvBrnCntrlIdNum
LMV SOFTWARE VERSION AZL	not writable	nvo(boiler)LmvSeVersionAzl
LMV SW VER BURNER CNTRL	not writable	nvo(boiler)LmvSwVerBrnCntrl
LMV SW VER LOAD CNTRL	not writable	nvo(boiler)LmvSwVerLoadCntrl
LMV MINIMUM OUTPUT GAS	not writable	nvo(boiler)LmvMinOutputGas
LMV MAXIMUM OUTPUT GAS	not writable	nvo(boiler)LmvMaxOutputGas
LMV MINIMUM OUTPUT OIL	not writable	nvo(boiler)LmvMinOutputOil
LMV MAXIMUM OUTPUT OIL	not writable	nvo(boiler)LmvMaxOutputOil
LMV LOAD LIMIT MODULATING	nvi(boiler)LmvLoadLimMod	nvo(boiler)LmvLoadLimMod
LMV LOAD LIMIT STAGING	nvi(boiler)LmvLoadLimStaging	nvo(boiler)LmvLoadLimStaging
LMV TEMP LIMIT ON THRESHOLD	not writable	nvo(boiler)LmvTempLimOn

Point List LonWorks - TS Series Touchscreen Kit (cont)

Point Name	LonWorks Input	LonWorks Output
LMV RANGE TEMP SENSOR	not writable	nvo(boiler)LmvRangeTempSens
LMV ADAPTION ACTIVE	not writable	nvo(boiler)LmvAdaptionActive
LMV ADAPTION STATE	not writable	nvo(boiler)LmvAdaptionState
LMV START ADAPTION	nvi(boiler)LmvStartAdaption	nvo(boiler)LmvStartAdaption
LMV ADAPTION OUTPUT	nvi(boiler)LmvAdaptionOutput	nvo(boiler)LmvAdaptionOutput
LMV P-VALUE	nvi(boiler)LmvP-Value	nvo(boiler)LmvP-Value
LMV I-VALUE	nvi(boiler)LmvI-Value	nvo(boiler)LmvI-Value
LMV D-VALUE	nvi(boiler)LmvD-Value	nvo(boiler)LmvD-Value
LMV LOCKOUT ERR CODE CURR	not writable	nvo(boiler)LmvLoErrCodeCurr
LMV LOCKOUT DIAG CODE CURR	not writable	nvo(boiler)LmvLoDiagCodeCurr
LMV LOCKOUT ERR CLASS CURR	not writable	nvo(boiler)LmvLoErrClassCurr
LMV LOCKOUT ERR PHASE CURR	not writable	nvo(boiler)LmvLoErrPhaseCurr
LMV LOCKOUT FUEL CURR	not writable	nvo(boiler)LmvLoFuelCurr
LMV LOCKOUT OUTPUT CURR	not writable	nvo(boiler)LmvLoOutputCurr
LMV LOCKOUT YEAR 2-DIG CURR	not writable	nvo(boiler)LmvLoDateTime
LMV LOCKOUT MONTH CURR	not writable	" "
LMV LOCKOUT DAY CURR	not writable	" "
LMV LOCKOUT HOUR CURR	not writable	" "
LMV LOCKOUT MINUTE CURR	nvi(boiler)LmvHrsRunGasRst	" "
LMV LOCKOUT SECOND CURR	not writable	" "
LMV LOCKOUT STARTUPS CURR	not writable	nvo(boiler)LmvLoStartsCurr
LMV LOCKOUT HOURS CURR	not writable	nvo(boiler)LmvLoHrsCurr
LMV ERR ERR CODE CURR	not writable	nvo(boiler)LmvErrErrCodeCurr
LMV ERR DIAG CODE CURR	not writable	nvo(boiler)LmvErrDiagCodeCur
LMV ERR ERR CLASS CURR	not writable	nvo(boiler)LmvErrErrClassCur
LMV ERR ERR PHASE CURR	not writable	nvo(boiler)LmvErrErrPhaseCur
LMV ERR FUEL CURR	not writable	nvo(boiler)LmvErrFuelCurr
LMV ERR OUTPUT CURR	not writable	nvo(boiler)LmvErrOutputCurr
LMV ERR STARTUPS CURR	not writable	nvo(boiler)LmvErrStartsCurr
EQUIPMENT FAULTS	not writable	nvo(boiler)EquipmentFaults
RWF LC INPUT WORD	not writable	nvo(boiler)RwflcInputWord
RWF LC OUTPUT WORD	not writable	nvo(boiler)RwflcOutputWord
RWF LC E1	not writable	nvo(boiler)RwflcE1
RWF LC E2	not writable	nvo(boiler)RwflcE2
RWF LC E3	not writable	nvo(boiler)RwflcE3
RWF LC WR CURR SP	not writable	nvo(boiler)RwflcWrCurrSp
RWF LC SP1	not writable	nvo(boiler)RwflcSp1
RWF LC SP2	not writable	nvo(boiler)RwflcSp2
RWF LC AL ALARM SP	not writable	nvo(boiler)RwflcAlAlarmSp
RWF LC PB1 PROPORTIONAL	not writable	nvo(boiler)RwflcPb1Prop
RWF LC DT DERIVATIVE	not writable	nvo(boiler)RwflcDtDerivative
RWF LC RT INTEGRAL	not writable	nvo(boiler)RwflcRtIntegral
RWF LC HYS1	not writable	nvo(boiler)RwflcHys1
RWF LC HYS3	not writable	nvo(boiler)RwflcHys3
RWF LC DTT WATCHDOG	not writable	nvo(boiler)RwflcDttWatchdog

Point List LonWorks - TS Series Touchscreen Kit (cont)

Point Name	LonWorks Input	LonWorks Output
RWF LC E3 UNFILTERED	not writable	nvo(boiler)RwfLcE3Unfiltered
RWF LC REM REMOTE OPERATION	not writable	nvo(boiler)RwfLcRemRemOp
RWF LC ROFF REMOTE OFF	not writable	nvo(boiler)RwfLcRoffRemOff
RWF LC RK1 REM BURNER CNTRL	not writable	nvo(boiler)RwfLcRk1RemBurner
RWF LC RK6 REMOTE K6 CNTRL	not writable	nvo(boiler)RwfLcRk6RemK6Cntl
RWF LC SPR REMOTE SETPOINT	not writable	nvo(boiler)RwfLcSprRemSp
RWF LC RY REMOTE OUTPUT	not writable	nvo(boiler)RwfLcRyRemOutput
RWF LC Y OUTPUT	not writable	nvo(boiler)RwfLcYOutput
RWF FW INPUT WORD	not writable	nvo(boiler)RwfFwInputWord
RWF FW OUTPUT WORD	not writable	nvo(boiler)RwfFwOutputWord
RWF FW LEVEL PERCENT	not writable	nvo(boiler)RwfFwLevelPercent
RWF FW SETPOINT PERCENT	not writable	nvo(boiler)RwfFwSpPercent
RWF FW E1	not writable	nvo(boiler)RwfFwE1
RWF FW E2	not writable	nvo(boiler)RwfFwE2
RWF FW E3	not writable	nvo(boiler)RwfFwE3
RWF FW WR CURR SP	not writable	nvo(boiler)RwfFwWrCurrSp
RWF FW SP1	not writable	nvo(boiler)RwfFwSp1
RWF FW SP2	not writable	nvo(boiler)RwfFwSp2
RWF FW Y	not writable	nvo(boiler)RwfFwY
RWF EX1 INPUT WORD	not writable	nvo(boiler)RwfEx1InputWord
RWF EX1 OUTPUT WORD	not writable	nvo(boiler)RwfEx1OutputWord
RWF EX1 E1	not writable	nvo(boiler)RwfEx1E1
RWF EX1 E2	not writable	nvo(boiler)RwfEx1E2
RWF EX1 E3	not writable	nvo(boiler)RwfEx1E3
RWF EX1 WR CURR SP	not writable	nvo(boiler)RwfEx1WrCurrSp
RWF EX1 SP1	not writable	nvo(boiler)RwfEx1Sp1
RWF EX1 SP2	not writable	nvo(boiler)RwfEx1Sp2
RWF EX1 AL ALARM SP	not writable	nvo(boiler)RwfEx1AlAlarmSp
RWF EX1 HYS1	not writable	nvo(boiler)RwfEx1Hys1
RWF EX1 HYS3	not writable	nvo(boiler)RwfEx1Hys3
RWF EX1 Y OUTPUT	not writable	nvo(boiler)RwfEx1YOutput
RWF EX2 INPUT WORD	not writable	nvo(boiler)RwfEx2InputWord
RWF EX2 OUTPUT WORD	not writable	nvo(boiler)RwfEx2OutputWord
RWF EX2 E1	not writable	nvo(boiler)RwfEx2E1
RWF EX2 E2	not writable	nvo(boiler)RwfEx2E2
RWF EX2 E3	not writable	nvo(boiler)RwfEx2E3
RWF EX2 WR CURR SP	not writable	nvo(boiler)RwfEx2WrCurrSp
RWF EX2 SP1	not writable	nvo(boiler)RwfEx2Sp1
RWF EX2 SP2	not writable	nvo(boiler)RwfEx2Sp2
RWF EX2 AL ALARM SP	not writable	nvo(boiler)RwfEx2AlAlarmSp
RWF EX2 HYS1	not writable	nvo(boiler)RwfEx2Hys1
RWF EX2 HYS3	not writable	nvo(boiler)RwfEx2Hys3
RWF EX2 Y OUTPUT	not writable	nvo(boiler)RwfEx2YOutput
EA DIGITAL INPUT WORD	not writable	nvo(boiler)EaDigitalInWord
EA STATUS WORD	not writable	nvo(boiler)EaStatusWord

Point List LonWorks - TS Series Touchscreen Kit (cont)

Point Name	LonWorks Input	LonWorks Output
EA ALARM WORD	not writable	nvo(boiler)EaAlarmWord
EA RTD 1	not writable	nvo(boiler)EaRtd1
EA RTD 2	not writable	nvo(boiler)EaRtd2
EA RTD 3	not writable	nvo(boiler)EaRtd3
EA RTD 4	not writable	nvo(boiler)EaRtd4
EA ANALOG INPUT 1	not writable	nvo(boiler)EaAnalogInput1
EA ANALOG INPUT 2	not writable	nvo(boiler)EaAnalogInput2
EA ANALOG INPUT 3	not writable	nvo(boiler)EaAnalogInput3
EA ANALOG INPUT 4	not writable	nvo(boiler)EaAnalogInput4
EA ECONOMIZER WATER IN	not writable	nvo(boiler)EaEconoWaterIn
EA ECONOMIZER WATER OUT	not writable	nvo(boiler)EaEconoWaterOut
EA ECONOMIZER STACK IN	not writable	nvo(boiler)EaEconoStackIn
EA ECONOMIZER STACK OUT	not writable	nvo(boiler)EaEconoStackOut
EA DRAFT FEEDBACK	not writable	nvo(boiler)EaDraftFeedback
EA DRAFT ALARM	not writable	nvo(boiler)EaDraftAlarm
EA DRAFT ALARM CODE	not writable	nvo(boiler)EaDraftAlarmCode
EA DRAFT ALARM PHASE	not writable	nvo(boiler)EaDraftAlarmPhase
EA DRAFT DRIVE WORD	not writable	nvo(boiler)EaDraftDriveWord
EA DRAFT SWITCH	not writable	nvo(boiler)EaDraftSwitch
EA DRAFT SENSOR	not writable	nvo(boiler)EaDraftSensor
EA LC INPUT WORD	not writable	nvo(boiler)EaLcInputWord
EA LC OUTPUT WORD	not writable	nvo(boiler)EaLcOutputWord
EA LC E1	not writable	nvo(boiler)EaLcE1
EA LC E3	not writable	nvo(boiler)EaLcE3
EA LC WR CURR SP	not writable	nvo(boiler)EaLcWrCurrSp
EA LC SP1	not writable	nvo(boiler)EaLcSp1
EA LC AL ALARM SP	not writable	nvo(boiler)EaLcAlAlarmSp
EA LC PB1 PROPORTIONAL	not writable	nvo(boiler)EaLcPb1Prop
EA LC DT DERIVATIVE	not writable	nvo(boiler)EaLcDtDerivative
EA LC RT INTEGRAL	not writable	nvo(boiler)EaLcRtIntegral
EA LC HYS1	not writable	nvo(boiler)EaLcHys1
EA LC HYS3	not writable	nvo(boiler)EaLcHys3
EA LC REM REMOTE OPERATION	not writable	nvo(boiler)EaLcRemRemOp
EA LC ROFF REMOTE OFF	not writable	nvo(boiler)EaLcRoffRemoteOff
EA LC RK1 REM BURNER CNTRL	not writable	nvo(boiler)EaLcRk1RemBrnCntl
EA LC SPR REMOTE SETPOINT	not writable	nvo(boiler)EaLcSprRemSp
EA LC RY REMOTE OUTPUT	not writable	nvo(boiler)EaLcRyRemOutput
EA LC Y OUTPUT	not writable	nvo(boiler)EaLcYOutput
VSD FREQ REF PERCENT	not writable	nvo(boiler)VsdFreqRefPercent
VSD OUTPUT FREQ PERCENT	not writable	nvo(boiler)VsdOutFreqPercent
VSD OUTPUT VOLTAGE	not writable	nvo(boiler)VsdOutputVoltage
VSD DC BUS VOLTAGE	not writable	nvo(boiler)VsdDcBusVoltage
VSD STATUS WORD	not writable	nvo(boiler)VsdStatusWord
VSD OUTPUT RPM	not writable	nvo(boiler)VsdOutputRpm
VSD OUTPUT CURR	not writable	nvo(boiler)VsdOutputCurr

Point List LonWorks - TS Series Touchscreen Kit (cont)

Point Name	LonWorks Input	LonWorks Output
VSD FREQ REFERENCE HERTZ	not writable	nvo(boiler)VsdFreqRefHertz
VSD OUTPUT FREQ HERTZ	not writable	nvo(boiler)VsdOutFreqHertz
VSD ALARM CODE	not writable	nvo(boiler)VsdAlarmCode
VSD FAULT CODE	not writable	nvo(boiler)VsdFaultCode
VSD DC BUS PEAK	not writable	nvo(boiler)VsdDcBusPeak
VSD OUTPUT CURR PEAK	not writable	nvo(boiler)VsdOutputCurrPeak
VSD OUTPUT POWER	not writable	nvo(boiler)VsdOutputPower
VSD TOTALIZED POWER	not writable	nvo(boiler)VsdTotalPower
LMV CNTRLLER SWITCH	not writable	nvo(boiler)LmvCNTRLSwitch
LMV FAN CONTACTOR	not writable	nvo(boiler)LmvFanContactor
LMV OIL SELECTED	not writable	nvo(boiler)LmvOilSelected
LMV GAS SELECTED	not writable	nvo(boiler)LmvGasSelected
LMV OIL PRESS SW MAX	not writable	nvo(boiler)LmvOilPressSwMax
LMV OIL PRESS SW MIN	not writable	nvo(boiler)LmvOilPressSwMin
LMV VALVE PROVING SW	not writable	nvo(boiler)LmvValveProvingSw
LMV SAFETY LOOP	not writable	nvo(boiler)LmvSafetyLoop
LMV GAS PRESS SW MIN	not writable	nvo(boiler)LmvGasPressSwMin
LMV GAS PRESS SW MAX	not writable	nvo(boiler)LmvGasPressSwMax
LMV AIR PRESSURE SW	not writable	nvo(boiler)LmvAirPressureSw
LMV START RELEASE OIL	not writable	nvo(boiler)LmvStartRelOil
LMV HEAVY OIL START	not writable	nvo(boiler)LmvHeavyOilStart
LMV ALARM	not writable	nvo(boiler)LmvAlarm
LMV IGNITION	not writable	nvo(boiler)LmvIgnition
LMV START SIGNAL	not writable	nvo(boiler)LmvStartSignal
LMV FAN OUTPUT	not writable	nvo(boiler)LmvFanOutput
LMV OIL PUMP	not writable	nvo(boiler)LmvOilPump
LMV FUEL VALVE SV OIL	not writable	nvo(boiler)LmvFuelValveSvOil
LMV FUEL VALVE V1 OIL	not writable	nvo(boiler)LmvFuelValveV1Oil
LMV FUEL VALVE V2 OIL	not writable	nvo(boiler)LmvFuelValveV2Oil
LMV FUEL VALVE V3 OIL	not writable	nvo(boiler)LmvFuelValveV3Oil
LMV FUEL VALVE SV GAS	not writable	nvo(boiler)LmvFuelValveSvGas
LMV FUEL VALVE V1 GAS	not writable	nvo(boiler)LmvFuelValveV1Gas
LMV FUEL VALVE V2 GAS	not writable	nvo(boiler)LmvFuelValveV2Gas
LMV FUEL VALVE PV GAS	not writable	nvo(boiler)LmvFuelValvePvGas
EQUIPMENT FAULT LMV5	not writable	nvo(boiler)EquipFltLmv5
EQUIPMENT FAULT LMV3	not writable	nvo(boiler)EquipFltLmv3
EQUIPMENT FAULT RWF10 LC	not writable	nvo(boiler)EquipFltRwf10Lc
EQUIPMENT FAULT RWF40 LC	not writable	nvo(boiler)EquipFltRwf40Lc
EQUIPMENT FAULT RWF55 LC	not writable	nvo(boiler)EquipFltRwf55Lc
EQUIPMENT FAULT RWF40 FW	not writable	nvo(boiler)EquipFltRwf40Fw
EQUIPMENT FAULT RWF55 FW	not writable	nvo(boiler)EquipFltRwf55Fw
EQUIPMENT FAULT EA	not writable	nvo(boiler)EquipmentFaultEa
EQUIPMENT FAULT VSD	not writable	nvo(boiler)EquipmentFaultVsd
RWF LC INPUT 1 FAULT	not writable	nvo(boiler)RwfLcInput1Fault
RWF LC INPUT 2 FAULT	not writable	nvo(boiler)RwfLcInput2Fault

Point List LonWorks - TS Series Touchscreen Kit (cont)

Point Name	LonWorks Input	LonWorks Output
RWF LC INPUT 3 FAULT	not writable	nvo(boiler)RwflcInput3Fault
RWF LC STAGE MODE	not writable	nvo(boiler)RwflcStageMode
RWF LC MANUAL OPERATION	not writable	nvo(boiler)RwflcManOp
RWF LC BINARY INPUT 1	not writable	nvo(boiler)RwflcBinaryInput1
RWF LC BINARY INPUT 2	not writable	nvo(boiler)RwflcBinaryInput2
RWF LC STAT ACTIVE	not writable	nvo(boiler)RwflcStatActive
RWF LC UP ACTIVE	not writable	nvo(boiler)RwflcUpActive
RWF LC DOWN ACTIVE	not writable	nvo(boiler)RwflcDownActive
RWF LC K6 ACTIVE	not writable	nvo(boiler)RwflcK6Active
RWF FW INPUT 1 FAULT	not writable	nvo(boiler)RwffwInput1Fault
RWF FW INPUT 2 FAULT	not writable	nvo(boiler)RwffwInput2Fault
RWF FW INPUT 3 FAULT	not writable	nvo(boiler)RwffwInput3Fault
RWF FW STAGE MODE	not writable	nvo(boiler)RwffwStageMode
RWF FW MANUAL OPERATION	not writable	nvo(boiler)RwffwManOp
RWF FW BINARY INPUT 1	not writable	nvo(boiler)RwffwBinaryInput1
RWF FW BINARY INPUT 2	not writable	nvo(boiler)RwffwBinaryInput2
RWF FW STAT ACTIVE	not writable	nvo(boiler)RwffwStatActive
RWF FW UP ACTIVE	not writable	nvo(boiler)RwffwUpActive
RWF FW DOWN ACTIVE	not writable	nvo(boiler)RwffwDownActive
RWF FW K6 ACTIVE	not writable	nvo(boiler)RwffwK6Active
RWF EX1 INPUT 1 FAULT	not writable	nvo(boiler)Rwfex1Input1Fault
RWF EX1 INPUT 2 FAULT	not writable	nvo(boiler)Rwfex1Input2Fault
RWF EX1 INPUT 3 FAULT	not writable	nvo(boiler)Rwfex1Input3Fault
RWF EX1 STAGE MODE	not writable	nvo(boiler)Rwfex1StageMode
RWF EX1 MANUAL OPERATION	not writable	nvo(boiler)Rwfex1ManOp
RWF EX1 BINARY INPUT 1	not writable	nvo(boiler)Rwfex1BinaryInp1
RWF EX1 BINARY INPUT 2	not writable	nvo(boiler)Rwfex1BinaryInp2
RWF EX1 STAT ACTIVE	not writable	nvo(boiler)Rwfex1StatActive
RWF EX1 UP ACTIVE	not writable	nvo(boiler)Rwfex1UpActive
RWF EX1 DOWN ACTIVE	not writable	nvo(boiler)Rwfex1DownActive
RWF EX1 K6 ACTIVE	not writable	nvo(boiler)Rwfex1K6Active
RWF EX2 INPUT 1 FAULT	not writable	nvo(boiler)Rwfex2Input1Fault
RWF EX2 INPUT 2 FAULT	not writable	nvo(boiler)Rwfex2Input2Fault
RWF EX2 INPUT 3 FAULT	not writable	nvo(boiler)Rwfex2Input3Fault
RWF EX2 STAGE MODE	not writable	nvo(boiler)Rwfex2StageMode
RWF EX2 MANUAL OPERATION	not writable	nvo(boiler)Rwfex2ManOp
RWF EX2 BINARY INPUT 1	not writable	nvo(boiler)Rwfex2BinaryIn1
RWF EX2 BINARY INPUT 2	not writable	nvo(boiler)Rwfex2BinaryIn2
RWF EX2 STAT ACTIVE	not writable	nvo(boiler)Rwfex2StatActive
RWF EX2 UP ACTIVE	not writable	nvo(boiler)Rwfex2UpActive
RWF EX2 DOWN ACTIVE	not writable	nvo(boiler)Rwfex2DownActive
RWF EX2 K6 ACTIVE	not writable	nvo(boiler)Rwfex2K6Active
EA INPUT 1	not writable	nvo(boiler)EaInput1
EA INPUT 2	not writable	nvo(boiler)EaInput2
EA INPUT 3	not writable	nvo(boiler)EaInput3

Point List LonWorks - TS Series Touchscreen Kit (cont)

Point Name	LonWorks Input	LonWorks Output
EA INPUT 4	not writable	nvo(boiler)EaInput4
EA INPUT 5	not writable	nvo(boiler)EaInput5
EA INPUT 6	not writable	nvo(boiler)EaInput6
EA INPUT 7	not writable	nvo(boiler)EaInput7
EA INPUT 8	not writable	nvo(boiler)EaInput8
EA INPUT 9	not writable	nvo(boiler)EaInput9
EA INPUT 10	not writable	nvo(boiler)EaInput10
EA INPUT 11	not writable	nvo(boiler)EaInput11
EA INPUT 12	not writable	nvo(boiler)EaInput12
EA INPUT 13	not writable	nvo(boiler)EaInput13
EA PUMP PROVEN	not writable	nvo(boiler)EaPumpProven
EA PUMP ALARM	not writable	nvo(boiler)EaPumpAlarm
EA AI1 HIGH ALARM	not writable	nvo(boiler)EaAi1HighAlarm
EA AI1 LOW ALARM	not writable	nvo(boiler)EaAi1LowAlarm
EA AI2 HIGH ALARM	not writable	nvo(boiler)EaAi2HighAlarm
EA AI2 LOW ALARM	not writable	nvo(boiler)EaAi2LowAlarm
EA AI3 HIGH ALARM	not writable	nvo(boiler)EaAi3HighAlarm
EA AI3 LOW ALARM	not writable	nvo(boiler)EaAi3LowAlarm
EA AI4 HIGH ALARM	not writable	nvo(boiler)EaAi4HighAlarm
EA AI4 LOW ALARM	not writable	nvo(boiler)EaAi4LowAlarm
EA AO1 HIGH ALARM	not writable	nvo(boiler)EaAo1HighAlarm
EA AO1 LOW ALARM	not writable	nvo(boiler)EaAo1LowAlarm
EA AO2 HIGH ALARM	not writable	nvo(boiler)EaAo2HighAlarm
EA AO2 LOW ALARM	not writable	nvo(boiler)EaAo2LowAlarm
EA ALARM INPUT 1	not writable	nvo(boiler)EaAlarmInput1
EA ALARM INPUT 2	not writable	nvo(boiler)EaAlarmInput2
EA ALARM INPUT 3	not writable	nvo(boiler)EaAlarmInput3
EA ALARM INPUT 4	not writable	nvo(boiler)EaAlarmInput4
EA ALARM INPUT 5	not writable	nvo(boiler)EaAlarmInput5
EA ALARM INPUT 6	not writable	nvo(boiler)EaAlarmInput6
EA ALARM INPUT 7	not writable	nvo(boiler)EaAlarmInput7
EA ALARM INPUT 8	not writable	nvo(boiler)EaAlarmInput8
EA ALARM INPUT 9	not writable	nvo(boiler)EaAlarmInput9
EA ALARM INPUT 10	not writable	nvo(boiler)EaAlarmInput10
EA ALARM INPUT 11	not writable	nvo(boiler)EaAlarmInput11
EA ALARM INPUT 12	not writable	nvo(boiler)EaAlarmInput12
EA ALARM INPUT 13	not writable	nvo(boiler)EaAlarmInput13
EA DRAFT OPEN POSITION	not writable	nvo(boiler)EaDraftOpenPos
EA DRAFT CLOSE POSITION	not writable	nvo(boiler)EaDraftClosePos
EA DRAFT START POSITION	not writable	nvo(boiler)EaDraftStartPos
EA DRAFT MODULATE	not writable	nvo(boiler)EaDraftModulate
EA LC STAT ACTIVE	not writable	nvo(boiler)EaLcStatActive
EA LC K6 ACTIVE	not writable	nvo(boiler)EaLcK6Active
VSD RUNNING	not writable	nvo(boiler)VsdRunning
VSD ZERO SPEED	not writable	nvo(boiler)VsdZeroSpeed

Point List LonWorks - TS Series Touchscreen Kit (cont)

Point Name	LonWorks Input	LonWorks Output
VSD SPEED AGREE	not writable	nvo(boiler)VsdSpeedAgree
VSD READY STATE	not writable	nvo(boiler)VsdReadyState
VSD ALARM STATE	not writable	nvo(boiler)VsdAlarmState
VSD FAULT STATE	not writable	nvo(boiler)VsdFaultState

(boiler) = Boiler designation. Example: Point for boiler 1 would be nvo1xxx.

Point List BACnet and Metasys N2 - TS Series Lead/Lag Master

Point Name	BACnet Obj Type	BACnet Obj ID	N2 Data Type	N2 Point Address
LLM REMOTE SETPOINT	AV	1	AO	1
LLM LEAD BOILER	AV	2	AO	2
LLM ALTERNATION SETPOINT	AI	3	AI	3
LLM ALT HOURS REMAINING	AI	4	AI	4
LLM CURRENT SETPOINT	AI	5	AI	5
LLM TOTAL AVAILABLE	AI	6	AI	6
LLM ACTUAL VALUE	AI	7	AI	7
LLM RTD 1	AI	8	AI	8
LLM RTD 2	AI	9	AI	9
LLM RTD 3	AI	10	AI	10
LLM RTD 4	AI	11	AI	11
LLM ANALOG INPUT 1	AI	12	AI	12
LLM ANALOG INPUT 2	AI	13	AI	13
LLM ANALOG INPUT 3	AI	14	AI	14
LLM ANALOG INPUT 4	AI	15	AI	15
LLM EXTRA INPUT	AV	16	AO	16
LLM LOAD DEMAND	AV	17	AO	17
LLM ANALOG INPUT 1 TOTALIZED	AI	18	AI	18
LLM ANALOG INPUT 2 TOTALIZED	AI	19	AI	19
LLM ANALOG INPUT 3 TOTALIZED	AI	20	AI	20
LLM ANALOG INPUT 4 TOTALIZED	AI	21	AI	21
LLM REMOTE ENABLE	BI	1	DI	1
LLM REMOTE VALID	BI	2	DI	2

Point List LonWorks - TS Series Lead/Lag Master

Point Name	LonWorks Input	LonWorks Output
LLM REMOTE SETPOINT	nvi(node)RemoteSetpoint	nvo(node)RemoteSetpoint
LLM LEAD BOILER	nvi(node)LeadBoiler	nvo(node)LeadBoiler
LLM ALTERNATION SETPOINT	not writable	nvo(node)AlternationSetpoint
LLM ALT HOURS REMAINING	not writable	nvo(node)AltHoursRemaining
LLM CURRENT SETPOINT	not writable	nvo(node)CurrentSetpoint
LLM TOTAL AVAILABLE	not writable	nvo(node)TotalAvailable
LLM ACTUAL VALUE	not writable	nvo(node)ActualValue
LLM RTD 1	not writable	nvo(node)Rtd1
LLM RTD 2	not writable	nvo(node)Rtd2
LLM RTD 3	not writable	nvo(node)Rtd3
LLM RTD 4	not writable	nvo(node)Rtd4
LLM ANALOG INPUT 1	not writable	nvo(node)AnalogInput1
LLM ANALOG INPUT 2	not writable	nvo(node)AnalogInput2
LLM ANALOG INPUT 3	not writable	nvo(node)AnalogInput3
LLM ANALOG INPUT 4	not writable	nvo(node)AnalogInput4
LLM EXTRA INPUT	nvi(node)ExtraInput	nvo(node)ExtraInput
LLM LOAD DEMAND	nvi(node)LoadDemand	nvo(node)LoadDemand
LLM ANALOG INPUT 1 TOTALIZED	not writable	nvo(node)AnalogInput1Total
LLM ANALOG INPUT 2 TOTALIZED	not writable	nvo(node)AnalogInput2Total
LLM ANALOG INPUT 3 TOTALIZED	not writable	nvo(node)AnalogInput3Total
LLM ANALOG INPUT 4 TOTALIZED	not writable	nvo(node)AnalogInput4Total
LLM REMOTE ENABLE	not writable	nvo(node)RemoteEnable
LLM REMOTE VALID	not writable	nvo(node)RemoteValid

(node) = Modbus address. Example: Point for device with Modbus address 1 would be nvo1xxx.

Point List BACnet and Metasys N2 - TS Series Lead/Lag Boiler

Point Name	BACnet Obj Type	BACnet Obj ID	N2 Data Type	N2 Point Address
Bx LMV PHASE	AI	1	AI	1
Bx LMV FUEL ACTUATOR	AI	2	AI	2
Bx LMV GAS ACTUATOR	AI	3	AI	3
Bx LMV OIL ACTUATOR	AI	4	AI	4
Bx LMV AIR ACTUATOR	AI	5	AI	5
Bx LMV AUX1 ACTUATOR	AI	6	AI	6
Bx LMV AUX2 ACTUATOR	AI	7	AI	7
Bx LMV AUX3 ACTUATOR	AI	8	AI	8
Bx LMV VSD OUTPUT	AI	9	AI	9
Bx LMV CURRENT OUTPUT	AI	10	AI	10
Bx LMV CURRENT SETPOINT	AI	11	AI	11
Bx LMV ACTUAL VALUE	AI	12	AI	12
Bx LMV FLAME SIGNAL	AI	13	AI	13
Bx LMV FUEL THROUGHPUT	AI	14	AI	14
Bx LMV CURRENT O ₂	AI	15	AI	15
Bx LMV STARTUP COUNTER	AI	16	AI	16
Bx LMV HOUR COUNTER	AI	17	AI	17
Bx LMV CURR ERROR CODE	AI	18	AI	18
Bx LMV CURR DIAG CODE	AI	19	AI	19
Bx LMV CURR ERROR CLASS	AI	20	AI	20
Bx LMV CURR ERROR PHASE	AI	21	AI	21
Bx LMV SUPPLY AIR TEMP	AI	22	AI	22
Bx LMV FLUE GAS TEMP	AI	23	AI	23
Bx LMV COMB EFFICIENCY	AI	24	AI	24
Bx LMV CURRENT CO ₂	AI	25	AI	25
Bx LMV CURRENT EXCESS AIR	AI	26	AI	26
Bx LMV LD CONTROL MODE	AI	27	AI	27
Bx LMV MODBUS SP W3	AI	28	AI	28
Bx LMV MODBUS OUTPUT	AI	29	AI	29
Bx LMV SETPOINT W1	AI	30	AI	30
Bx LMV VOLUME GAS/FUELO	AI	31	AI	31
Bx LMV VOLUME OIL/FUEL1	AI	32	AI	32
Bx LMV TEMP SENSOR	AI	33	AI	33
Bx RWF E1	AI	34	AI	34
Bx RWF E2	AI	35	AI	35
Bx RWF E3	AI	36	AI	36
Bx RWF WR CURRENT SP	AI	37	AI	37
Bx RWF SP1	AI	38	AI	38
Bx FW E1	AI	39	AI	39
Bx FW E2	AI	40	AI	40
Bx FW WR CURRENT SP	AI	41	AI	41
Bx FW SP1	AI	42	AI	42
Bx BOILER AUTO	BI	1	DI	1
Bx BOILER AVAILABLE	BI	2	DI	2
Bx BOILER PUMP RUNNING	BI	3	DI	3

Point List BACnet and Metasys N2 - TS Series Lead/Lag Boiler (cont)

Point Name	BACnet Obj Type	BACnet Obj ID	N2 Data Type	N2 Point Address
Bx BOILER PUMP ALARM	BI	4	DI	4
Bx LMV CURRENT FUEL	BI	5	DI	5
Bx LMV CONTROLLER SW	BI	6	DI	6
Bx LMV FAN CONTACTOR	BI	7	DI	7
Bx LMV OIL SELECTED	BI	8	DI	8
Bx LMV GAS SELECTED	BI	9	DI	9
Bx LMV OIL PRESS SW MAX	BI	10	DI	10
Bx LMV OIL PRESS SW MIN	BI	11	DI	11
Bx LMV VALVE PROVING SW	BI	12	DI	12
Bx LMV SAFETY LOOP	BI	13	DI	13
Bx LMV GAS PRESS SW MIN	BI	14	DI	14
Bx LMV GAS PRESS SW MAX	BI	15	DI	15
Bx LMV AIR PRESSURE SW	BI	16	DI	16
Bx LMV START REL OIL	BI	17	DI	17
Bx LMV HEAVY OIL START	BI	18	DI	18
Bx LMV ALARM	BI	19	DI	19
Bx LMV IGNITION	BI	20	DI	20
Bx LMV START SIGNAL	BI	21	DI	21
Bx LMV FAN OUTPUT	BI	22	DI	22
Bx LMV OIL PUMP	BI	23	DI	23
Bx LMV VALVE SV OIL	BI	24	DI	24
Bx LMV VALVE V1 OIL	BI	25	DI	25
Bx LMV VALVE V2 OIL	BI	26	DI	26
Bx LMV VALVE V3 OIL	BI	27	DI	27
Bx LMV VALVE SV GAS	BI	28	DI	28
Bx LMV VALVE V1 GAS	BI	29	DI	29
Bx LMV VALVE V2 GAS	BI	30	DI	30
Bx LMV VALVE PV GAS	BI	31	DI	31
Bx LMV MODBUS LOC/REM	BI	32	DI	32
Bx RWF INPUT 1 FAULT	BI	33	DI	33
Bx RWF INPUT 2 FAULT	BI	34	DI	34
Bx RWF INPUT 3 FAULT	BI	35	DI	35
Bx RWF STAGE MODE	BI	36	DI	36
Bx RWF MANUAL OPERATION	BI	37	DI	37
Bx RWF BINARY INPUT 1	BI	38	DI	38
Bx RWF BINARY INPUT 2	BI	39	DI	39
Bx RWF STAT ACTIVE	BI	40	DI	40
Bx RWF UP ACTIVE	BI	41	DI	41
Bx RWF DOWN ACTIVE	BI	42	DI	42
Bx RWF K6 ACTIVE	BI	43	DI	43

Point List LonWorks - TS Series Lead/Lag Boiler

Point Name	LonWorks Input	LonWorks Output
Bx LMV PHASE	not writable	nvo(boiler)LmvPhase
Bx LMV FUEL ACTUATOR	not writable	nvo(boiler)LmvFuelActuator
Bx LMV GAS ACTUATOR	not writable	nvo(boiler)LmvGasActuator
Bx LMV OIL ACTUATOR	not writable	nvo(boiler)LmvOilActuator
Bx LMV AIR ACTUATOR	not writable	nvo(boiler)LmvAirActuator
Bx LMV AUX1 ACTUATOR	not writable	nvo(boiler)LmvAux1Actuator
Bx LMV AUX2 ACTUATOR	not writable	nvo(boiler)LmvAux2Actuator
Bx LMV AUX3 ACTUATOR	not writable	nvo(boiler)LmvAux3Actuator
Bx LMV VSD OUTPUT	not writable	nvo(boiler)LmvVsdOutput
Bx LMV CURRENT OUTPUT	not writable	nvo(boiler)LmvCurrOutput
Bx LMV CURRENT SETPOINT	not writable	nvo(boiler)LmvCurrSetpoint
Bx LMV ACTUAL VALUE	not writable	nvo(boiler)LmvActualValue
Bx LMV FLAME SIGNAL	not writable	nvo(boiler)LmvFlameSignal
Bx LMV FUEL THROUGHPUT	not writable	nvo(boiler)LmvFuelThroughput
Bx LMV CURRENT O ₂	not writable	nvo(boiler)LmvCurrO2
Bx LMV STARTUP COUNTER	not writable	nvo(boiler)LmvStartupCounter
Bx LMV HOUR COUNTER	not writable	nvo(boiler)LmvHourCounter
Bx LMV CURR ERROR CODE	not writable	nvo(boiler)LmvCurrErrorCode
Bx LMV CURR DIAG CODE	not writable	nvo(boiler)LmvCurrDiagCode
Bx LMV CURR ERROR CLASS	not writable	nvo(boiler)LmvCurrErrorClass
Bx LMV CURR ERROR PHASE	not writable	nvo(boiler)LmvCurrErrorPhase
Bx LMV SUPPLY AIR TEMP	not writable	nvo(boiler)LmvSupplyAirTemp
Bx LMV FLUE GAS TEMP	not writable	nvo(boiler)LmvFlueGasTemp
Bx LMV COMB EFFICIENCY	not writable	nvo(boiler)LmvCombEfficiency
Bx LMV CURRENT CO ₂	not writable	nvo(boiler)LmvCurrCO2
Bx LMV CURRENT EXCESS AIR	not writable	nvo(boiler)LmvCurrExAir
Bx LMV LD CONTROL MODE	not writable	nvo(boiler)LmvLdControlMode
Bx LMV MODBUS SP W3	not writable	nvo(boiler)LmvModbusSpW3
Bx LMV MODBUS OUTPUT	not writable	nvo(boiler)LmvModbusOutput
Bx LMV SETPOINT W1	not writable	nvo(boiler)LmvSetpointW1
Bx LMV VOLUME GAS/FUELO	not writable	nvo(boiler)LmvVolGas/Fuel0
Bx LMV VOLUME OIL/FUEL1	not writable	nvo(boiler)LmvVolOil/Fuel1
Bx LMV TEMP SENSOR	not writable	nvo(boiler)LmvTempSensor
Bx RWF E1	not writable	nvo(boiler)RwfE1
Bx RWF E2	not writable	nvo(boiler)RwfE2
Bx RWF E3	not writable	nvo(boiler)RwfE3
Bx RWF WR CURRENT SP	not writable	nvo(boiler)RwfWrCurrSp
Bx RWF SP1	not writable	nvo(boiler)RwfSp1
Bx FW E1	not writable	nvo(boiler)FwE1
Bx FW E2	not writable	nvo(boiler)FwE2
Bx FW WR CURRENT SP	not writable	nvo(boiler)FwWrCurrSp
Bx FW SP1	not writable	nvo(boiler)FwSp1
Bx BOILER AUTO	not writable	nvo(boiler)BoilerAuto
Bx BOILER AVAILABLE	not writable	nvo(boiler)BoilerAvailable
Bx BOILER PUMP RUNNING	not writable	nvo(boiler)BoilerPumpRunning

Point List LonWorks - TS Series Lead/Lag Boiler (cont)

Point Name	LonWorks Input	LonWorks Output
Bx BOILER PUMP ALARM	not writable	nvo(boiler)BoilerPumpAlarm
Bx LMV CURRENT FUEL	not writable	nvo(boiler)LmvCurrFuel
Bx LMV CONTROLLER SW	not writable	nvo(boiler)LmvControllerSw
Bx LMV FAN CONTACTOR	not writable	nvo(boiler)LmvFanContactor
Bx LMV OIL SELECTED	not writable	nvo(boiler)LmvOilSelected
Bx LMV GAS SELECTED	not writable	nvo(boiler)LmvGasSelected
Bx LMV OIL PRESS SW MAX	not writable	nvo(boiler)LmvOilPressSwMax
Bx LMV OIL PRESS SW MIN	not writable	nvo(boiler)LmvOilPressSwMin
Bx LMV VALVE PROVING SW	not writable	nvo(boiler)LmvValveProvingSw
Bx LMV SAFETY LOOP	not writable	nvo(boiler)LmvSafetyLoop
Bx LMV GAS PRESS SW MIN	not writable	nvo(boiler)LmvGasPressSwMin
Bx LMV GAS PRESS SW MAX	not writable	nvo(boiler)LmvGasPressSwMax
Bx LMV AIR PRESSURE SW	not writable	nvo(boiler)LmvAirPressureSw
Bx LMV START REL OIL	not writable	nvo(boiler)LmvStartRelOil
Bx LMV HEAVY OIL START	not writable	nvo(boiler)LmvHeavyOilStart
Bx LMV ALARM	not writable	nvo(boiler)LmvAlarm
Bx LMV IGNITION	not writable	nvo(boiler)LmvIgnition
Bx LMV START SIGNAL	not writable	nvo(boiler)LmvStartSignal
Bx LMV FAN OUTPUT	not writable	nvo(boiler)LmvFanOutput
Bx LMV OIL PUMP	not writable	nvo(boiler)LmvOilPump
Bx LMV VALVE SV OIL	not writable	nvo(boiler)LmvValveSvOil
Bx LMV VALVE V1 OIL	not writable	nvo(boiler)LmvValveV1Oil
Bx LMV VALVE V2 OIL	not writable	nvo(boiler)LmvValveV2Oil
Bx LMV VALVE V3 OIL	not writable	nvo(boiler)LmvValveV3Oil
Bx LMV VALVE SV GAS	not writable	nvo(boiler)LmvValveSvGas
Bx LMV VALVE V1 GAS	not writable	nvo(boiler)LmvValveV1Gas
Bx LMV VALVE V2 GAS	not writable	nvo(boiler)LmvValveV2Gas
Bx LMV VALVE PV GAS	not writable	nvo(boiler)LmvValvePvGas
Bx LMV MODBUS LOC/REM	not writable	nvo(boiler)LmvModbusLoc/Rem
Bx RWF INPUT 1 FAULT	not writable	nvo(boiler)RwfInput1Fault
Bx RWF INPUT 2 FAULT	not writable	nvo(boiler)RwfInput2Fault
Bx RWF INPUT 3 FAULT	not writable	nvo(boiler)RwfInput3Fault
Bx RWF STAGE MODE	not writable	nvo(boiler)RwfStageMode
Bx RWF MANUAL OPERATION	not writable	nvo(boiler)RwfManualOp
Bx RWF BINARY INPUT 1	not writable	nvo(boiler)RwfBinaryInput1
Bx RWF BINARY INPUT 2	not writable	nvo(boiler)RwfBinaryInput2
Bx RWF STAT ACTIVE	not writable	nvo(boiler)RwfStatActive
Bx RWF UP ACTIVE	not writable	nvo(boiler)RwfUpActive
Bx RWF DOWN ACTIVE	not writable	nvo(boiler)RwfDownActive
Bx RWF K6 ACTIVE	not writable	nvo(boiler)RwfK6Active

(boiler) = Boiler designation. Example: Point for boiler 1 would be nvo1xxx.

Point List Modbus TCP/IP

The Modbus TCP/IP point lists duplicate the native Modbus/RTU point lists. For each of the LMV3, LMV5, RWF10, RWF40, RWF55 and TS Series Deaerator/Surge Tank Master devices, there is an appendix containing the native Modbus/RTU point lists. For the TS Series Touchscreen Kit, see Document No. TS-1100 for additional detail. For the TS Series Lead/Lag Master, see Document No. TS-2100 for additional detail.

Appendix - LMV5 Wiring

The LMV5... has an native RS-232 interface via the port 'COM2' on the AZL5... To connect this port to the TS-P...2 or to an RS-232 to RS-485 converter, follow the wiring diagram shown. 'COM2' uses a physical RJ-45 connection, so using a common Cat5e cable and converting one end to flying leads is a good method to use to connect the port.

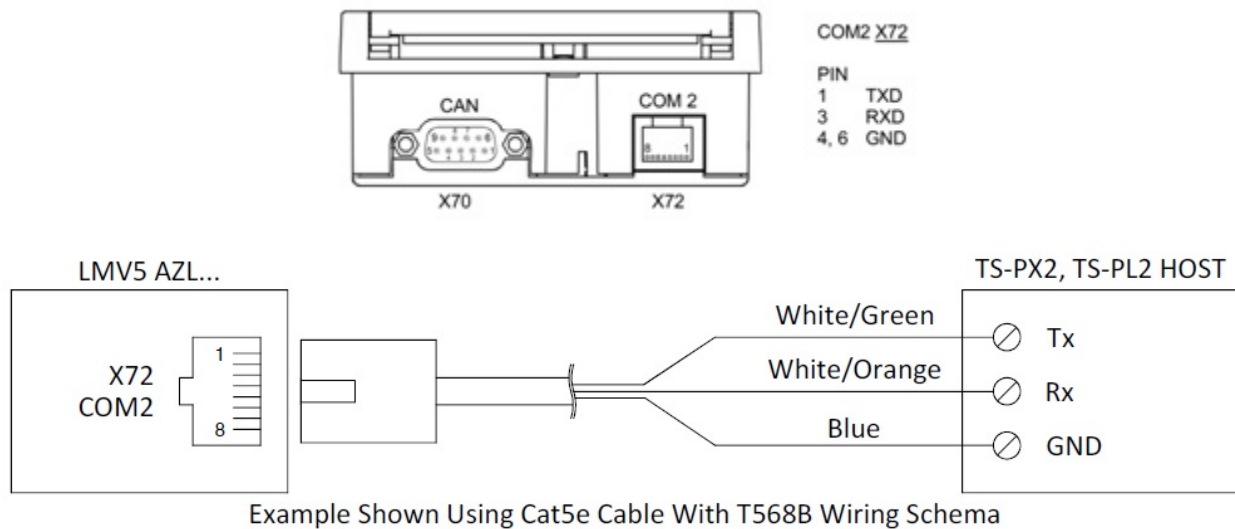

Appendix - RS-485 Wiring

RS-485 is a physical medium that allows multiple devices to be connected together on a common network. The recommended topology for an RS-485 network is the 'point-to-point' (aka daisy-chained) network. This is a network where each device is connected directly to the device before it, forming a chain from the beginning to the end of the network. Star or hybrid topologies, where devices spur off of a central device or another device in the chain, are not recommended as noise can be introduced into the network.

RS-485 networks should be connected using cables containing a twisted-pair. The signaling in an RS-485 network is based upon the differential of voltages across the wires, and the twisted-pair helps ensure that any possible interference will carry onto both wires (keeping the correct differential voltage as a result). If a common ground terminal is provided on the equipment, that should be connected across the network as well. Polarity is important when connecting devices. The two main connections are commonly marked as '+' and '-', 'A' and 'B' or something similar. Resistance across the network is important as well, and the ends of the network should be terminated with resistors that complement the resistance of the cabling used (typically 120-Ohm).

The maximum distance that an RS-485 network should span is 4,000 feet and it should ideally have 64 or fewer nodes. Using an RS-485 repeater in the network can extend these limits when necessary.

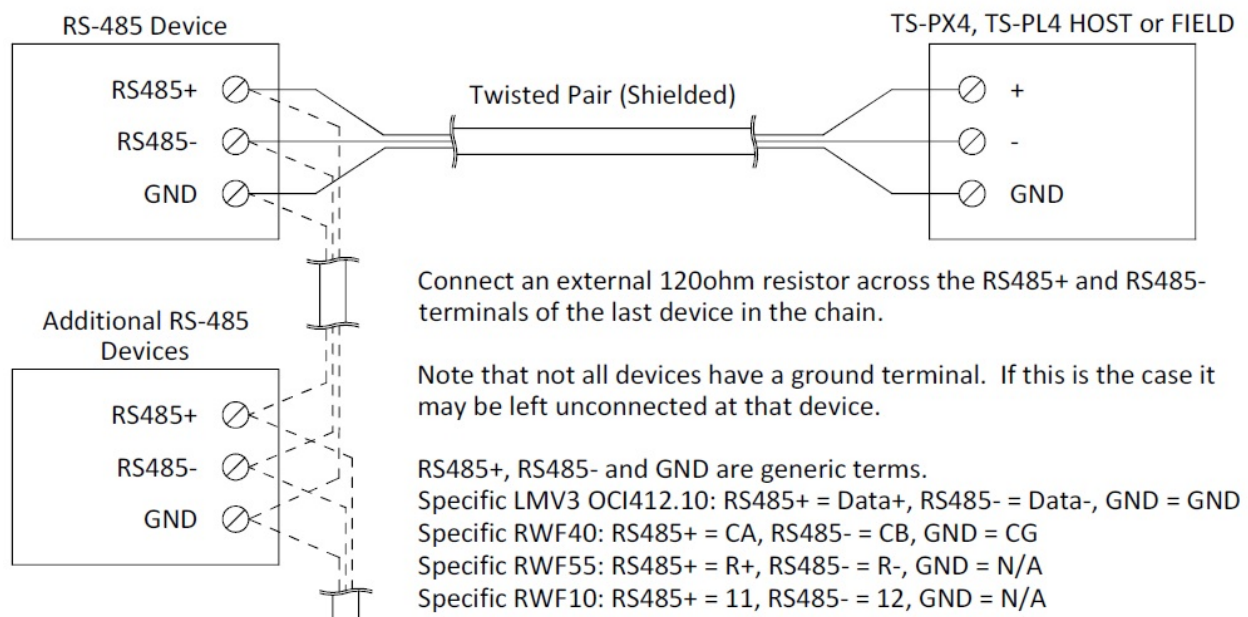

Appendix - LMV3 Configuration for Modbus

The LMV3x controller must have the OCI412.10 option installed in order to communicate with the system via Modbus.

The service (heating engineer) password must be entered for these parameters to be accessed. The default service password is 9876. If the password has been changed, please consult the equipment OEM for the correct password.

To configure the LMV3x controller to communicate using Modbus, use the following procedure:

1. Hold down both the **F** and the **A** buttons until the display reads 'Code', followed by a string of seven underscores.
2. Use the **+** and **-** buttons to enter the password. Press **ENTER** (the button to the right of the display) after each entry, and again once the complete password is entered. If the password is incorrect, 'Error' will be displayed and the process will have to be restarted.
3. If the password is entered successfully, the screen will display 'Para' and then '400: Set' with the '400:' flashing.
4. Use the **-** button to navigate to '100: PARa', then press **ENTER**.
5. Use the **+** and **-** buttons to navigate to a flashing '141:'. If this value does not read '1', press **ENTER** and then use the **+** and **-** buttons to change it to '1', then press **ENTER** to confirm the change. This parameter activates Modbus. To return to the parameter navigation, press the **+** and **-** buttons simultaneously (**ESC**). The display should return to flashing '141:'. This procedure will be used to change all parameters.
6. Change '142:' **0-7200** (timeout in seconds)
7. Change '145:' **1-247**
8. Change '146:' **0 or 1** (0 = 9600, 1 = 19200 bit/s)
9. Change '147:' **0-2** (0 = none, 1 = odd and 2 = even)
10. When all the parameters are entered, press **ESC** in two successions to back up to the main screen. The changes take effect immediately (no reboot required).

Appendix - LMV5 Configuration for Modbus

The LMV5x controller must be properly configured for Modbus operation. Use the **Select <** and **Select >** buttons to navigate up and down the screen and the **Enter** button when the desired option is selected with the cursor. Use **Esc** to go back to the previous menu. When a parameter needs to be changed, the **Select <** and **Select >** buttons allow the value to be changed and **Enter** confirms the change. Press the **Esc** button to return after the change is made.

First, activate the Modbus port on the AZL (no password required):

1. Operation > OptgModeSelect > Type of Gateway = **Modbus**
 2. Operation > OptgModeSelect > **GatewayBASon**
- Note: Older AZL units may read 'GatewayDDCon' instead.
3. The AZL should now read 'Gateway Mode active'.

Next, set up the required parameters through the AZL (no password required):

1. Params & Display > Access w-out PW > AZL > Modbus > Address = **1-247**
2. Params & Display > Access w-out PW > AZL > Modbus > Baudrate = **9600 or 19200 bit/s**
3. Params & Display > Access w-out PW > AZL > Modbus > Parity = **none, odd, even**
4. Params & Display > Access w-out PW > AZL > Modbus > Timeout = **0-7200s**

Last, change the controller mode to allow Modbus operation (no password required):

Params & Display > Access w-out PW > LoadController > Configuration > LC_OptgMode =
IntLC Bus

The changes take effect immediately (no reboot required).

Appendix - RWF55 Configuration for Modbus

The RWF55 must be properly configured for Modbus operation.

Use the up and down arrow buttons to navigate through the menus and the **Enter** button when the desired menu is selected. Use **Esc** to go back to the previous menu. When a parameter needs to be changed, the up and down arrow buttons allow the value to be changed and **Enter** confirms the change. The parameter name will flash on the green display when the parameter entry mode is entered. Press the **Esc** button to return after the change is made.

To configure the RWF55 controller to communicate using Modbus, use the following procedure:

1. Press **Enter** to go into the menu list. The green display should read 'OPr'.
2. ConF > IntF > r485 > bdr = **0-3** (0 = 4800, 1 = 9600, 2 = 19200, 3 = 38400 bit/s)
3. ConF > IntF > r485 > dtt = **0-7200** (timeout in seconds)
4. ConF > IntF > r485 > Adr = **1-254**
5. Press **Esc** in four successions or until the parameter menus are completely exited. The changes take effect immediately (no reboot required).

Appendix - RWF40 Configuration for Modbus

The RWF40 must have the Modbus option in order to communicate with the system. The last three characters of the part number must be 'B97' for Modbus to be optioned. If the last three characters of the part number are 'A97', Modbus is not optioned.

To activate Modbus on the RWF40, make the following and parameters:

1. Press and hold **PGM** until the green display shows 'AL'.
2. Press and hold **PGM** until the green display shows 'C111'.
3. Press **PGM** twice so that the green display shows 'C113'.
4. Press the down arrow until the second red digit from the right flashes. Use the up arrow to change this value to **3** for 9600 bit/s or to **7** for 19200 bit/s.
5. Press the down arrow until the second red digit from the left flashes. This is the second digit of the Modbus address. The address can be in the range of **01** to **99**. Use the up arrow to change this value, then press the down arrow until the first red digit flashes and repeat for the first digit of the Modbus address.
6. Press **PGM**. The red display should now read **xx30** or **xx70**. If it does not, use the down and up arrows to adjust the value and then press **PGM** to confirm and save the values.
7. Press **EXIT** to return to the normal display. The changes take effect immediately (no reboot required).

Appendix - RWF10 Configuration for Modbus

The RWF10 must have the Modbus option in order to communicate with the system. This is an option card that is inserted into the controller when required.

To configure the RWF10 controller to communicate using Modbus, use the following procedure:

1. Press the **LEVEL** (left-most) button until the red display reads 'CN-t'.
2. Press the **LEVEL** button again; the red display should read 'PSEL'.
3. If the value of 'PSEL' does not read 'Mod', use the up and down arrow buttons to change the value.
4. Press the **MODE** (loop with arrow on end, second from left) button to move to the next parameter, 'U-No'. Change to the value between **1** and **99** with the up and down arrow buttons and then press **MODE**. This parameter sets the Modbus address.
5. Change parameter 'bPS' to **9.6** for 9600 bit/s, **19.2** for 19200 bit/s or **38.4** for 38400 bit/s and then press **MODE**. This parameter sets the baud rate.
6. Change parameter 'PRtY' to **None**, **Even**, or **Odd** and then press **MODE**. This parameter sets the parity.
7. Change parameter 'SdWt' to a value between **0** and **99** and then press **MODE**. This parameter sets the timeout.
8. Once 'PSEL' is displayed again, press and hold the **LEVEL** button to save the changes. The unit will reboot with the new parameters and the changes will take effect immediately.

Appendix - TS Series Configuration

TS Series Deaerator/Surge Tank Master

The default IP address for the TS Series Deaerator/Surge Tank Master is 192.168.1.58 with a subnet mask of 255.255.255.0. See Document No. TS-3100 for additional detail.

TS Series Touchscreen Kit

The default IP address for the TS Series Touchscreen Kit is 192.168.1.60 with a subnet mask of 255.255.255.0 and a boiler number of 1. If multiple TS Series Touchscreen Kits are connected to the network, each must be assigned a unique IP address and boiler designation. See Document No. TS-1100 for additional detail.

TS Series Lead/Lag Master

For ETHERNET port connections, the default IP address for the TS Series Lead/Lag Master is 192.168.1.69 with a subnet mask of 255.255.255.0. For HOST port connections, the default settings for the RS-485 connection is node address 1, 38400 baud, 8 data bits, 1 stop bit and no parity. If necessary, these parameters can be changed. See Document No. TS-2100 for additional detail.

Appendix - LMV3 Native Modbus/RTU Mapping

Point Name	Address	Words	Format	Access	Notes
LMV PHASE	0	1	U16	R	
LMV FUEL ACTUATOR	1	1	S16	R	x10
LMV AIR ACTUATOR	4	1	S16	R	x10
LMV VSD OUTPUT	8	1	S16	R	x10
LMV CURRENT FUEL	9	1	U16	R	0=fuel0, 1=fuel1
LMV CURRENT OUTPUT	10	1	U16	R	x10 (1001=S1, 1002=S2, 1003=S3)
LMV FLAME SIGNAL	13	1	U16	R	x10
LMV FUEL THROUGHPUT	14	1	U16	R	x10
LMV STARTUP COUNTER	21	2	U32	R	
LMV CURRENT ERROR CODE	25	1	U16	R	
LMV CURRENT DIAGNOSTIC CODE	26	1	U16	R	
LMV CURRENT ERROR CLASS	27	1	U16	R	
LMV CURRENT ERROR PHASE	28	1	U16	R	
LMV INPUT WORD	35	1	U16	R	
LMV CONTROLLER SWITCH	B0		Bit		
LMV VALVE PROVING SW	B7		Bit		
LMV SAFETY LOOP	B8		Bit		
LMV GAS PRESS SW MIN	B10		Bit		
LMV GAS PRESS SW MAX	B11		Bit		
LMV AIR PRESSURE SW	B13		Bit		
LMV OUTPUT WORD	37	1	U16	R	
LMV ALARM	B0		Bit		
LMV IGNITION	B4		Bit		
LMV FAN OUTPUT	B6		Bit		
LMV FUEL VALVE V1	B13		Bit		
LMV FUEL VALVE V2	B14		Bit		
LMV FUEL VALVE V3/PV	B15		Bit		
LMV PROGRAM STOP	38	1	U16	RW	see Note 1
LMV MODBUS LOCAL/REMOTE	41	1	U16	RW	0=local, 1=remote
LMV MODBUS WATCHDOG	42	1	U16	RW	
LMV MODBUS OPERATING MODE	43	1	U16	RW	0=auto, 1=on, 2=off
LMV MODBUS OUTPUT	45	1	U16	RW	x10 (1001=S1, 1002=S2, 1003=S3)
LMV HOURS RUN FUEL 0 RESET	56	2	U32	RW	
LMV HOURS RUN FUEL 1 RESET	58	2	U32	RW	
LMV HOURS CONNECT TO POWER	68	2	U32	RW	
LMV STARTUPS FUEL 0 RESET	70	2	U32	RW	
LMV STARTUPS FUEL 1 RESET	72	2	U32	RW	
LMV STARTUPS TOTAL FIXED	76	2	U32	R	
LMV TOTAL VOLUME FUEL0	78	2	U32	R	
LMV TOTAL VOLUME FUEL1	80	2	U32	R	
LMV NUMBER OF LOCKOUTS	82	1	U16	R	
LMV PRESELECT OUTPUT FUEL 0	84	1	U16	RW	x10 (1001=S1, 1002=S2, 1003=S3)
LMV PRESELECT OUTPUT FUEL 1	85	1	U16	RW	x10 (1001=S1, 1002=S2, 1003=S3)
LMV BC TYPE REFERENCE	98	8	String	R	
LMV BC PARAMETER SET CODE	106	1	U16	R	

Appendix - LMV3 Native Modbus/RTU Mapping (continued)

Point Name	Address	Words	Format	Access	Notes
LMV BC PARAMETER SET VER	107	1	U16	R	
LMV BC ID DATE	108	3	U16	R	word order (year, month, day)
LMV BURNER CONTROL ID NUM	111	1	U16	R	
LMV SW VER BURNER CONTROL	113	1	U16	R	
LMV BURNER ID	115	8	String	R	
LMV MINIMUM OUTPUT FUEL 0	123	1	U16	R	x10 (1001=S1, 1002=S2, 1003=S3)
LMV MAXIMUM OUTPUT FUEL 0	124	1	U16	R	x10 (1001=S1, 1002=S2, 1003=S3)
LMV MINIMUM OUTPUT FUEL 1	125	1	U16	R	x10 (1001=S1, 1002=S2, 1003=S3)
LMV MAXIMUM OUTPUT FUEL 1	126	1	U16	R	x10 (1001=S1, 1002=S2, 1003=S3)
LMV OPERATION MODE FUEL 0	127	1	U16	R	1-27
LMV OPERATION MODE FUEL 1	128	1	U16	R	1-27
LMV CYCLES REVERT TO PILOT	129	2	U32	R	
LMV ERROR ERR CODE CURRENT	544 + x	1	U16	R	see Note 2
LMV ERROR DIAG CODE CURRENT	545 + x	1	U16	R	
LMV ERROR ERR CLASS CURRENT	546 + x	1	U16	R	
LMV ERROR ERR PHASE CURRENT	547 + x	1	U16	R	
LMV ERROR FUEL CURRENT	548 + x	1	U16	R	0=fuel0, 1=fuel1
LMV ERROR OUTPUT CURRENT	549 + x	1	U16	R	x10 (1001=S1, 1002=S2, 1003=S3)
LMV ERROR STARTUPS CURRENT	550 + x	2	U32	R	

Note 1 – LMV program stop.

- **0:** deactivated
- **1:** prepurge phase 24
- **2:** ignition position phase 36
- **3:** interval 1 phase 44
- **4:** interval 2 phase 52

Note 2 – There are 25 errors in memory, the current plus the last 24. The addresses for the historical data are in the same format as the current data (544 through 551) with an offset added that equals 8 times the history index. For example, the current error code for history index 4 would be $544 + (8 \times 4) = 576$.

Appendix - LMV5 Native Modbus/RTU Mapping

Point Name	Address	Words	Format	Access	Notes
LMV PHASE	0	1	U16	R	
LMV FUEL ACTUATOR	1	1	S16	R	x10
LMV GAS ACTUATOR	2	1	S16	R	x10
LMV OIL ACTUATOR	3	1	S16	R	x10
LMV AIR ACTUATOR	4	1	S16	R	x10
LMV AUX1 ACTUATOR	5	1	S16	R	x10
LMV AUX2 ACTUATOR	6	1	S16	R	x10
LMV AUX3 ACTUATOR	7	1	S16	R	x10
LMV VSD OUTPUT	8	1	U16	R	x10
LMV CURRENT FUEL	9	1	U16	R	0=gas, 1=oil
LMV CURRENT OUTPUT	10	1	U16	R	x10 (1001=S1, 1002=S2, 1003=S3)
LMV CURRENT SETPOINT	11	1	U16	R	
LMV ACTUAL VALUE	12	1	U16	R	
LMV FLAME SIGNAL	13	1	U16	R	x10
LMV FUEL THROUGHPUT	14	1	U16	R	
LMV CURRENT O ₂	15	1	U16	R	x10
LMV GAS UNIT	16	1	U16	R	0=metric, 1=standard
LMV OIL UNIT	17	1	U16	R	0=metric, 1=standard
LMV TEMPERATURE UNIT	18	1	U16	R	0=metric, 1=standard
LMV PRESSURE UNIT	19	1	U16	R	0=metric, 1=standard
LMV SENSOR SELECTION	20	1	U16	R	see Note 1
LMV STARTUP COUNTER	21	2	U32	R	
LMV HOUR COUNTER	23	2	U32	R	
LMV CURRENT ERROR CODE	25	1	U16	R	
LMV CURRENT DIAGNOSTIC CODE	26	1	U16	R	
LMV CURRENT ERROR CLASS	27	1	U16	R	
LMV CURRENT ERROR PHASE	28	1	U16	R	
LMV TEMP LIMIT OFF THRESHOLD	29	1	U16	R	
LMV SUPPLY AIR TEMPERATURE	30	1	U16	R	
LMV FLUE GAS TEMPERATURE	31	1	U16	R	
LMV COMBUSTION EFFICIENCY	32	1	U16	R	x10
LMV INPUT WORD	35	1	U16	R	
LMV CONTROLLER SWITCH	B0		Bit	R	
LMV FAN CONTACTOR	B1		Bit	R	
LMV OIL SELECTED	B2		Bit	R	
LMV GAS SELECTED	B3		Bit	R	
LMV OIL PRESS SW MAX	B5		Bit	R	
LMV OIL PRESS SW MIN	B6		Bit	R	
LMV VALVE PROVING SW	B7		Bit	R	
LMV SAFETY LOOP	B8		Bit	R	
LMV GAS PRESS SW MIN	B10		Bit	R	
LMV GAS PRESS SW MAX	B11		Bit	R	
LMV AIR PRESSURE SW	B13		Bit	R	
LMV START RELEASE OIL	B14		Bit	R	
LMV HEAVY OIL START	B15		Bit	R	

Appendix - LMV5 Native Modbus/RTU Mapping (continued)

Point Name	Address	Words	Format	Access	Notes
LMV OUTPUT WORD	37	1	U16	R	
LMV ALARM	B0		Bit	R	
LMV IGNITION	B4		Bit	R	
LMV START SIGNAL	B5		Bit	R	
LMV FAN OUTPUT	B6		Bit	R	
LMV OIL PUMP	B7		Bit	R	
LMV FUEL VALVE SV OIL	B8		Bit	R	
LMV FUEL VALVE V1 OIL	B9		Bit	R	
LMV FUEL VALVE V2 OIL	B10		Bit	R	
LMV FUEL VALVE V3 OIL	B11		Bit	R	
LMV FUEL VALVE SV GAS	B12		Bit	R	
LMV FUEL VALVE V1 GAS	B13		Bit	R	
LMV FUEL VALVE V2 GAS	B14		Bit	R	
LMV FUEL VALVE PV GAS	B15		Bit	R	
LMV PROGRAM STOP	38	1	U16	RW	see Note 2
LMV LOAD CONTROL MODE	39	1	U16	RW	see Note 3
LMV MANUAL/AUTOMATIC	40	1	U16	R	0=auto, 1=on, 2=off
LMV MODBUS LOCAL/REMOTE	41	1	U16	RW	0=local, 1=remote
LMV MODBUS WATCHDOG	42	1	U16	RW	
LMV MODBUS OPERATING MODE	43	1	U16	RW	0=auto, 1=on, 2=off
LMV MODBUS SETPOINT W3	44	1	U16	RW	
LMV MODBUS OUTPUT	45	1	U16	RW	x10 (1001=S1, 1002=S2, 1003=S3)
LMV MODBUS FUEL SELECTION	46	1	U16	RW	0=gas, 1=oil
LMV SETPOINT W1	47	1	U16	RW	
LMV SETPOINT W2	48	1	U16	RW	
LMV WEEKDAY	49	1	U16	RW	0=Sunday, 1=Monday, etc.
LMV DATE	50	3	U16	RW	
LMV TIME	53	3	U16	RW	
LMV HOURS RUN GAS RESET	56	2	U32	RW	
LMV HOURS RUN OIL S1 RESET	58	2	U32	RW	
LMV HOURS RUN OIL S2 RESET	60	2	U32	RW	
LMV HOURS RUN OIL S3 RESET	62	2	U32	RW	
LMV HOURS RUN TOTAL RESET	64	2	U32	RW	
LMV HOURS RUN TOTAL FIXED	66	2	U32	R	
LMV HOURS CONNECT TO POWER	68	2	U32	R	
LMV STARTUPS GAS RESET	70	2	U32	RW	
LMV STARTUPS OIL RESET	72	2	U32	RW	
LMV STARTUPS TOTAL RESET	74	2	U32	RW	
LMV STARTUPS TOTAL FIXED	76	2	U32	R	
LMV TOTAL VOLUME GAS	78	2	U32	RW	
LMV TOTAL VOLUME OIL	80	2	U32	RW	
LMV NUMBER OF LOCKOUTS	82	1	U16	R	
LMV EXTRA TEMP SENSOR	83	1	U16	R	
LMV AZL5 ASN	84	8	String	R	
LMV AZL5 PARAMETER SET CODE	92	1	U16	R	

Appendix - LMV5 Native Modbus/RTU Mapping (continued)

Point Name	Address	Words	Format	Access	Notes
LMV AZL5 PARAMETER SET VER	93	1	U16	R	
LMV AZL5 ID DATE	94	3	U16	R	
LMV AZL5 ID NUMBER	97	1	U16	R	
LMV BC CONTROL ASN	98	8	String	R	
LMV BC PARAMETER SET CODE	106	1	U16	R	
LMV BC PARAMETER SET VER	107	1	U16	R	
LMV BC ID DATE	108	3	U16	R	
LMV BURNER CNTRL ID NUMBER	111	1	U16	R	
LMV SOFTWARE VERSION AZL	112	1	U16	R	
LMV SW VER BURNER CONTROL	113	1	U16	R	
LMV SW VER LOAD CONTROL	114	1	U16	R	
LMV BURNER ID	115	8	String	R	
LMV MINIMUM OUTPUT GAS	123	1	U16	R	x10
LMV MAXIMUM OUTPUT GAS	124	1	U16	R	x10
LMV MINIMUM OUTPUT OIL	125	1	U16	R	x10 (1001=S1, 1002=S2, 1003=S3)
LMV MAXIMUM OUTPUT OIL	126	1	U16	R	x10 (1001=S1, 1002=S2, 1003=S3)
LMV LOAD LIMIT MODULATING	127	1	U16	RW	x10
LMV LOAD LIMIT STAGING	128	1	U16	RW	0=S1, 1=S2, 2=S3
LMV TEMP LIMIT ON THRESHOLD	129	1	S16	R	x10 (-50% to 0%)
LMV RANGE TEMP SENSOR	130	1	U16	R	0=302F, 1=752F, 2=1562F
LMV ADAPTION ACTIVE	131	1	U16	R	0=inactive, 1=active
LMV ADAPTION STATE	132	1	U16	R	see Note 4
LMV START ADAPTION	133	1	U16	RW	0=reset, 1=start, 2=abort
LMV ADAPTION OUTPUT	134	1	U16	RW	x10 (40% to 100%)
LMV P-VALUE	135	1	U16	RW	x10 (2% to 500%)
LMV I-VALUE	136	1	U16	RW	seconds
LMV D-VALUE	137	1	U16	RW	seconds
LMV LOCKOUT ERR CODE CURR	400 + x	1	U16	R	see Note 5
LMV LOCKOUT DIAG CODE CURR	401 + x	1	U16	R	
LMV LOCKOUT ERR CLASS CURR	402 + x	1	U16	R	
LMV LOCKOUT ERR PHASE CURR	403 + x	1	U16	R	
LMV LOCKOUT FUEL CURR	404 + x	1	U16	R	
LMV LOCKOUT OUTPUT CURR	405 + x	1	U16	R	x10 (1001=S1, 1002=S2, 1003=S3)
LMV LOCKOUT DATE CURR	406 + x	3	U16	R	
LMV LOCKOUT TIME CURR	409 + x	3	U16	R	
LMV LOCKOUT STARTUPS CURR	412 + x	2	U32	R	
LMV LOCKOUT HOURS CURR	414 + x	2	U32	R	
LMV ERROR ERROR CODE CURR	544 + y	1	U16	R	see Note 6
LMV ERROR DIAG CODE CURR	545 + y	1	U16	R	
LMV ERROR ERROR CLASS CURR	546 + y	1	U16	R	
LMV ERROR ERROR PHASE CURR	547 + y	1	U16	R	
LMV ERROR FUEL CURR	548 + y	1	U16	R	
LMV ERROR OUTPUT CURR	549 + y	1	U16	R	x10 (1001=S1, 1002=S2, 1003=S3)
LMV ERROR STARTUPS CURR	550 + y	2	U32	R	

Appendix - LMV5 Native Modbus/RTU Mapping (continued)

Note 1 – LMV5 sensor selection.

- **0:** Pt100
- **1:** Pt1000
- **2:** Ni1000
- **3:** temperature sensor
- **4:** pressure sensor
- **5:** Pt100/Pt1000
- **6:** Pt100/Ni1000
- **7:** no sensor

Note 2 – LMV program stop.

- **0:** deactivated
- **1:** prepurge phase 24
- **2:** prepurge FGR phase 32
- **3:** ignition position phase 36
- **4:** interval 1 phase 44
- **5:** interval 2 phase 52
- **6:** postpurge phase 72
- **7:** postpurge FGR phase 76

Note 3 – LMV5 operating mode.

- **0:** external load control X5-03
- **1:** internal load control
- **2:** internal load control bus
- **3:** internal load control X62
- **4:** external load control X62
- **5:** external load control bus

Note 4 – LMV5 adaption state.

- **0:** undefined
- **1:** identification completed, parameter determined
- **2:** undefined
- **3:** adaption aborted by user
- **4:** temperature difference too small, temperature will be lowered with low fire
- **5:** monitoring time running
- **6:** delivery of identification load set
- **7:** error during identification (path)
- **8:** error during identification (internal)
- **9:** monitoring time running
- **10:** changeover from modulating to multistage during an identification
- **11:** timeout monitoring time
- **12:** timeout heating output on path with monitoring

Appendix - LMV5 Native Modbus/RTU Mapping (continued)

Note 5 – There are 9 lockouts in memory, the current plus the last 8. The addresses for the historical data are in the same format as the current data (400 through 415) with an offset added that equals 16 times the history index. For example, the current error code for history index 4 would be $400 + (16 \times 4) = 464$.

Note 6 – There are 21 errors in memory, the current plus the last 20. The addresses for the historical data are in the same format as the current data (544 through 551) with an offset added that equals 8 times the history index. For example, the current error code for history index 4 would be $544 + (8 \times 4) = 576$.

Appendix - RWF55 Native Modbus/RTU Mapping

Point Name	Address Decimal	Address Hex	Words	Format	Access
INPUT 1 X1	0	0x0000	2	Float	R
INPUT 2 X2	2	0x0002	2	Float	R
INPUT 3 X3	4	0x0004	2	Float	R
CURRENT SETPOINT WR	6	0x0006	2	Float	R
FIRST SETPOINT SP1	8	0x0008	2	Float	RW
SECOND SETPOINT SP2	10	0x000A	2	Float	RW
OUTPUTS AND STATES	512	0x0200	1	U16	R
INPUT 1 FAULT	B12		Bit		
INPUT 2 FAULT	B13		Bit		
INPUT 3 FAULT	B14		Bit		
INPUTS AND SIGNALS	513	0x0201	1	U16	R
STAGE MODE	B0		Bit		
MANUAL OPERATION	B1		Bit		
BINARY INPUT 1	B2		Bit		
BINARY INPUT 2	B3		Bit		
STAT ACTIVE	B4		Bit		
UP ACTIVE	B5		Bit		
DOWN ACTIVE	B6		Bit		
K6 ACTIVE	B7		Bit		
REMOTE OPERATING MODE REM	1280	0x0500	1	U16	RW
REMOTE MODE OFF ROFF	1281	0x0501	1	U16	RW
REMOTE ON HYSTERESIS RHYS1	1282	0x0502	2	Float	RW
REMOTE OFF HYST BOT RHYS2	1284	0x0504	2	Float	RW
REMOTE OFF HYST TOP RHYS3	1286	0x0506	2	Float	RW
REMOTE SETPOINT SPR	1288	0x0508	2	Float	RW
REMOTE BURNER OUTPUT RK1	1290	0x050A	2	Float	RW
REMOTE K2 OUTPUT RK2	1291	0x050B	1	U16	RW
REMOTE K3 OUTPUT RK3	1292	0x050C	1	U16	RW
REMOTE K6 OUTPUT RK6	1293	0x050D	1	U16	RW
REMOTE STAGE MODE RSTEP	1294	0x050E	1	U16	RW
REMOTE OUTPUT RY	1295	0x050F	2	Float	RW
REM ON HYST COOLING RHYS4	1297	0x0511	2	Float	RW
REM OFF HYST BTM COOL RHYS5	1299	0x0513	2	Float	RW
REM OFF HYST TOP COOL RHYS6	1301	0x0515	2	Float	RW
INPUT 3 UNFILTERED TEMP	4149	0x1035	2	Float	R
ACTUAL OUTPUT Y	4163	0x1043	2	Float	R
BURNER ALARM	4184	0x1058	1	U16	R
RAMP FUNCTION FnCt	4195	0x1063	1	U16	RW
RAMP SLOPE rASL	4197	0x1065	2	Float	RW
TOLERANCE BAND RAMP toLP	4199	0x1067	2	Float	RW
LIMIT VALUE rAL	4201	0x1069	2	Float	RW
ALARM RELAY FUNCTION FnAL	4205	0x106D	1	U16	RW
ALARM LIMIT COMPARATOR AL	4207	0x106F	2	Float	RW
HYSTERESIS LIMIT COMP HYST	4209	0x1071	2	Float	RW
MODBUS WATCHDOG dtt	4213	0x1075	2	Float	RW

Appendix - RWF55 Native Modbus/RTU Mapping (continued)

Point Name	Address Decimal	Address Hex	Words	Format	Access
FILTER INPUT 1 dF1	4215	0x1077	2	Float	RW
FILTER INPUT 2 dF2	4217	0x1079	2	Float	RW
FILTER INPUT 3 dF3	4219	0x107B	2	Float	RW
ACTUAL VALUE LIMIT LOW oLLo	4221	0x107D	2	Float	R
ACTUAL VALUE LIMIT HIGH oLHi	4223	0x107F	2	Float	R
PROPORTIONAL BAND Pb1	12288	0x3000	2	Float	RW
DERIVATIVE ACTION TIME dt	12292	0x3004	2	Float	RW
INTEGRAL ACTION TIME rt	12294	0x3006	2	Float	RW
DEAD BAND db	12300	0x300C	2	Float	RW
ACTUATOR RUNNING TIME tt	12306	0x3012	1	U16	RW
ON HYSTERESIS HYS1	12310	0x3016	2	Float	RW
OFF HYSTERESIS BOTTOM HYS2	12312	0x3018	2	Float	RW
OFF HYSTERESIS TOP HYS3	12314	0x301A	2	Float	RW
ON HYST COOLING HYS4	12316	0x301C	2	Float	RW
OFF HYST BTM COOLING HYS5	12318	0x301E	2	Float	RW
OFF HYST TOP COOLING HYS6	12320	0x3020	2	Float	RW
REACTION THRESHOLD q	12322	0x3022	2	Float	RW
OUTSIDE TEMPERATURE 1 At1	12416	0x3080	2	Float	RW
BOILER TEMPERATURE 1 Ht1	12418	0x3082	2	Float	RW
OUTSIDE TEMPERATURE 2 At2	12420	0x3084	2	Float	RW
BOILER TEMPERATURE 2 Ht2	12422	0x3086	2	Float	RW
INPUT 1 SCALE LOW SCL1	13350	0x3426	2	Float	RW
INPUT 1 SCALE HIGH SCH1	13352	0x3428	2	Float	RW
OFFSET INPUT 1 OFF1	13354	0x342A	2	Float	RW
INPUT 2 SCALE LOW SCL2	13362	0x3432	2	Float	RW
INPUT 2 SCALE HIGH SCH2	13364	0x3434	2	Float	RW
OFFSET INPUT 2 OFF2	13366	0x3436	2	Float	RW
OFFSET INPUT 3 OFF3	13370	0x343A	2	Float	RW
SETPOINT LIMIT SCALE LOW SPL	13446	0x3486	2	Float	RW
SETPOINT LIMIT SCALE HIGH SPH	13448	0x3488	2	Float	RW
SOFTWARE VERSION	32768	0x8000	6	String	R
VdN NUMBER	32774	0x8006	8	String	R

Appendix - RWF40 Native Modbus/RTU Mapping

Point Name	Address Decimal	Address Hex	Words	Format	Access
INPUT 1 E1	0	0x0000	Float	2	R
INPUT 2 E2	2	0x0002	Float	2	R
INPUT 3 E3	4	0x0004	Float	2	R
CURRENT SETPOINT CSP	6	0x0006	Float	2	R
FIRST SETPOINT SP1	8	0x0008	Float	2	RW
SECOND SETPOINT SP2	10	0x000A	Float	2	RW
ALARM LIMIT COMPARATOR AL	12	0x000C	Float	2	RW
PROPORTIONAL BAND Pb1	14	0x000E	Float	2	RW
DERIVATIVE ACTION TIME dt	16	0x0010	Float	2	RW
INTEGRAL ACTION TIME rt	18	0x0012	Float	2	RW
DEAD BAND db	20	0x0014	Float	2	RW
ACTUATOR RUNNING TIME tt	22	0x0016	Float	2	RW
ON HYSTERESIS HYS1	24	0x0018	Float	2	RW
OFF HYSTERESIS BOTTOM HYS2	26	0x001A	Float	2	RW
OFF HYSTERESIS TOP HYS3	28	0x001C	Float	2	RW
REACTION THRESHOLD q	30	0x001E	Float	2	RW
HEATING CURVE SLOPE H	32	0x0020	Float	2	RW
PARALLEL DISPLACEMENT P	34	0x0022	Float	2	RW
C111	36	0x0024	String	2	RW
C112	38	0x0026	String	2	RW
C113	40	0x0028	String	2	RW
C000	42	0x002A	String	2	RW
INPUT 1 SCALE LOW SCL	44	0x002C	Float	2	RW
INPUT 1 SCALE HIGH SCH	46	0x002E	Float	2	RW
INPUT 2 SCALE LOW SCL2	48	0x0030	Float	2	RW
INPUT 2 SCALE HIGH SCH2	50	0x0032	Float	2	RW
SETPOINT LIMIT SCALE LOW SPL	52	0x0034	Float	2	RW
SETPOINT LIMIT SCALE HIGH SPH	54	0x0036	Float	2	RW
OFFSET INPUT 1 OFF1	56	0x0038	Float	2	RW
OFFSET INPUT 2 OFF2	58	0x003A	Float	2	RW
OFFSET INPUT 3 OFF3	60	0x003C	Float	2	RW
HYSTERESIS LIMIT COMP HYST	62	0x003E	Float	2	RW
FILTER INPUT 1 dF1	64	0x0040	Float	2	RW
FILTER INPUT 3 dF3	66	0x0042	Float	2	RW
MODBUS WATCHDOG dtt	68	0x0044	Float	2	RW
ACTUAL VALUE LIMIT LOW oLLo	70	0x0046	Float	2	R
ACTUAL VALUE LIMIT HIGH oLHi	72	0x0048	Float	2	R
OUTPUTS AND STATES	512	0x0200	1	U16	R
INPUT 1 FAULT	B12		Bit		
INPUT 2 FAULT	B13		Bit		
INPUT 3 FAULT	B14		Bit		
INPUTS AND SIGNALS	513	0x0201	1	U16	R
STAGE MODE	B0		Bit		
MANUAL OPERATION	B1		Bit		
BINARY INPUT 1	B2		Bit		

Appendix - RWF40 Native Modbus/RTU Mapping (continued)

Point Name	Address Decimal	Address Hex	Words	Format	Access
BINARY INPUT 2	B3		Bit		
STAT ACTIVE	B4		Bit		
UP ACTIVE	B5		Bit		
DOWN ACTIVE	B6		Bit		
K6 ACTIVE	B7		Bit		
SOFTWARE VERSION	768	0x0300	String	6	R
VdN VERSION	774	0x0306	String	8	R
INPUT 3 UNFILTERED TEMP	1024	0x0400	Float	2	R
REMOTE OPERATING MODE REM	1280	0x0500	U16	1	RW
REMOTE MODE OFF ROFF	1281	0x0501	U16	1	RW
REMOTE ON HYSTERESIS RHYS1	1282	0x0502	Float	2	RW
REMOTE OFF HYST BOT RHYS2	1284	0x0504	Float	2	RW
REMOTE OFF HYST TOP RHYS3	1286	0x0506	Float	2	RW
REMOTE SETPOINT SPR	1288	0x0508	Float	2	RW
REMOTE BURNER OUTPUT RK1	1290	0x050A	U16	1	RW
REMOTE K2 OUTPUT RK2	1291	0x050B	U16	1	RW
REMOTE K3 OUTPUT RK3	1292	0x050C	U16	1	RW
REMOTE K6 OUTPUT RK6	1293	0x050D	U16	1	RW
REMOTE STAGE MODE RSTEP	1294	0x050E	U16	1	RW
REMOTE OUTPUT RY	1295	0x050F	Float	2	RW

Appendix - RWF10 Native Modbus/RTU Mapping

Point Name	Address	Words	Format	Access	Notes
PROCESS VARIABLE	8192	1	U16	R	
STATUS WORD	8193	1	U16	R	
OUTPUT ALARM 1 BURNER	B12		Bit		
OUTPUT ALARM 2 LF HOLD	B13		Bit		
ANALOG OUTPUT	8196	1	U16	R	x10
CURRENT SETPOINT	8451	1	U16	RW	x10 or x100 if decimal places used
SETPOINT ALARM 1	8452	1	U16	RW	
SETPOINT ALARM 2	8455	1	U16	RW	
PROPORTIONAL BAND	10752	1	U16	RW	x10
INTEGRAL TIME	10753	1	U16	RW	
DERIVATIVE TIME	10754	1	U16	RW	
HYSTERESIS ALARM 1	12034	1	U16	RW	
HYSTERESIS ALARM 2	12037	1	U16	RW	

Appendix - LMV Phases

NUMBER	DESCRIPTION
0	LOCKOUT PHASE
1	SAFETY PHASE
2	SAFETY PHASE
10	HOME RUN POSITION
12	STANDBY STATIONARY
20	SAFETY RELAY ON
21	RELEASE OF STARTUP
22	FAN MOTOR ON
24	DRIVE TO PURGE
30	PREPURGE
32	PREPURGE FGR
34	PREPURGE
36	DRIVE TO IGNITION
38	PREIGNITION SPARK ON
39	GAS VALVE TEST MINIMUM PRESSURE
40	PILOT VALVE OPEN
42	SPARK OFF
44	INTERVAL 1 PILOT STABILIZE
50	FUEL VALVE OPEN SAFETY TIME 2
52	PILOT VALVE CLOSED INTERVAL 2 MAIN FLAME
54	DRIVE TO LOW FIRE PRE
60	NORMAL OPERATION
62	DRIVE TO LOW FIRE POST
70	FV CLOSED AFTER BURN TIME
72	DRIVE TO POSTPURGE
74	MANDATORY POSTPURGE
76	MANDATORY POSTPURGE
78	OPTIONAL POSTPURGE
79	DIRECT START (APS CHECK)
80	GV TEST EVACUATION OF TEST SPACE
81	GV TEST ATMOSPHERIC PRESSURE TEST
82	GV TEST FILL TEST SPACE
83	GV TEST PRESSURE TEST
90	GAS SHORTAGE WAITING TIME
97	NO CONFIGURATION
98	WAITING TO ESTABLISH COMMUNICATION
99	COMMUNICATION FAULT

Appendix - LMV3 Error Codes

CODE	DESCRIPTION
2	NO FLAME AT END OF SAFETY TIME
3	AIR PRESSURE FAILURE
4	EXTRANEIOUS LIGHT
7	LOSS OF FLAME
12	VALVE PROVING
14	PROOF OF CLOSURE
19	COMBUSTION PRESSURE POC
20	PRESSURE SWITCH - MINIMUM
21	PRESSURE SWITCH - MAXIMUM
22	SAFETY LOOP / BURNER FLANGE
50	INTERNAL ERROR
51	INTERNAL ERROR
55	INTERNAL ERROR
56	INTERNAL ERROR
57	INTERNAL ERROR
58	INTERNAL ERROR
60	INTERNAL ERROR - NO VALID HEAT SOURCE
61	FUEL CHANGEOVER
62	INVALID FUEL SIGNALS OR INFORMATION
65	INTERNAL ERROR
66	INTERNAL ERROR
67	INTERNAL ERROR
70	INTERNAL ERROR - FUEL/AIR RATIO CONTROL
71	SPECIAL POSITION UNDEFINED
72	INTERNAL ERROR - FUEL/AIR RATIO CONTROL
73	INTERNAL ERROR - FUEL/AIR RATIO CONTROL
75	INTERNAL ERROR - FUEL/AIR RATIO CONTROL
76	INTERNAL ERROR - FUEL/AIR RATIO CONTROL
80	CONTROL RANGE LIMIT OF VSD
81	VSD ELECTROMAGNETIC INTERFERENCE
82	ERROR DURING VSD SPEED STANDARDIZATION
83	SPEED ERROR VSD
84	CURVE SLOPE ACTUATORS
85	ACTUATOR REFERENCING ERROR
86	ERROR FUEL ACTUATOR
87	ERROR AIR ACTUATOR
90	INTERNAL ERROR - BASIC UNIT
91	INTERNAL ERROR - BASIC UNIT
93	ERROR FLAME SIGNAL ACQUISITION
95	ERROR RELAY SUPERVISION
96	ERROR RELAY SUPERVISION
97	ERROR RELAY SUPERVISION
98	ERROR RELAY SUPERVISION
99	INTERNAL ERROR - RELAY CONTROL
100	INTERNAL ERROR - RELAY CONTROL
105	INTERNAL ERROR - CONTACT SAMPLING

Appendix - LMV3 Error Codes (continued)

CODE	DESCRIPTION
106	INTERNAL ERROR - CONTACT REQUEST
107	INTERNAL ERROR - CONTACT REQUEST
108	INTERNAL ERROR - CONTACT REQUEST
110	INTERNAL ERROR - VOLTAGE MONITOR TEST
111	POWER FAILURE
112	MAINS VOLTAGE RECOVERY
113	INTERNAL ERROR - MAINS VOLTAGE
115	INTERNAL ERROR - SYSTEM COUNTER
116	DESIGN THRESHOLD EXCEEDED
117	LIFETIME EXCEEDED - OPERATION NOT ALLOWED
120	FUEL METERING INTERFERENCE
121	INTERNAL ERROR - EEPROM ACCESS
122	INTERNAL ERROR - EEPROM ACCESS
123	INTERNAL ERROR - EEPROM ACCESS
124	INTERNAL ERROR - EEPROM ACCESS
125	INTERNAL ERROR - EEPROM READ ACCESS
126	INTERNAL ERROR - EEPROM WRITE ACCESS
127	INTERNAL ERROR - EEPROM ACCESS
128	INTERNAL ERROR - EEPROM ACCESS
129	INTERNAL ERROR - EEPROM ACCESS
130	INTERNAL ERROR - EEPROM ACCESS
131	INTERNAL ERROR - EEPROM ACCESS
132	INTERNAL ERROR - EEPROM REG INITIALIZATION
133	INTERNAL ERROR - EEPROM REQUEST SYNC
134	INTERNAL ERROR - EEPROM REQUEST SYNC
135	INTERNAL ERROR - EEPROM REQUEST SYNC
136	RESTORE STARTED
137	INTERNAL ERROR - BACKUP/RESTORE
146	TIMEOUT - BAS MODBUS
150	TUV TEST
165	INTERNAL ERROR
166	INTERNAL ERROR - WATCHDOG TEST
167	MANUAL LOCKING
168	INTERNAL ERROR - MANAGEMENT
169	INTERNAL ERROR - MANAGEMENT
170	INTERNAL ERROR - MANAGEMENT
171	INTERNAL ERROR - MANAGEMENT
200	NO ERROR
201	PREVENTION OF STARTUP
202	INTERNAL ERROR - OPERATING MODE SELECT
203	INTERNAL ERROR
204	PROGRAM STOP
205	INTERNAL ERROR
206	COMBINATION OF UNITS NOT ALLOWED
207	AZL VERSION COMPATIBILITY ERROR
208	INTERNAL ERROR

Appendix - LMV3 Error Codes (continued)

CODE	DESCRIPTION
209	INTERNAL ERROR
210	SELECTED MODE NOT RELEASED FOR BASIC UNIT
240	INTERNAL ERROR
245	INTERNAL ERROR
250	INTERNAL ERROR

Appendix - LMV5 Lockout / Error Codes

CODE DECIMAL	CODE HEX	DESCRIPTION
0	0	NO ERROR
1	1	ROM ERROR
2	2	RAM ERROR
3	3	INTERNAL COMMUNICATION ERROR
4	4	UNSUCCESSFUL SYNC OF 2uCs
5	5	FAULT DURING FLAME AMP TEST
6	6	FAULT INTERNAL HARDWARE TEST
16	10	DIGITAL OUTPUT FAULT
17	11	SHORT CIRCUIT CONTACT FEEDBACK
21	15	ACTUATOR FAULT/VSD SPEED NOT REACHED
22	16	FAULT IN RATIO CONTROL SYSTEM
23	17	LMV5 INTERNAL COM ERROR
24	18	CORRUPTION IN COMBUSTION CURVE DATA
25	19	ACTUATOR POT ERROR
26	1A	ACTUATOR CURVE TOO STEEP
27	1B	ACT CURVE PROG STILL ACTIVE PHASE 62
28	1C	ACTUATOR IGNITION POSITION NOT SET
29	1D	RUNNING TIME FAULT ACTUATORS/VSD
30	1E	ACTUATOR/VSD NOT REACHED POSITION
31	1F	VSD MODULE CONNECTION ERROR
33	21	SAFETY LOOP OPEN
34	22	TEMP LIMITER OFF (CHECK SENSOR)
35	23	EXTRANEIOUS LIGHT DURING STARTUP
36	24	EXTRANEIOUS LIGHT DURING SHUTDOWN
37	25	NO FLAME AT END OF SAFETY TIME
38	26	LOSS OF FLAME PHASE 60-62
39	27	AIR PROVE SW ON SHOULD BE OFF
40	28	AIR PROVE SW OFF SHOULD BE ON
41	29	FAN CONTACT SIGNAL ON SHOULD BE OFF
42	2A	FAN CONTACT SIGNAL OFF SHOULD BE ON
43	2B	FGR PRESSURE SW ON SHOULD BE OFF
44	2C	FGR PRESSURE SW OFF SHOULD BE ON
45	2D	CPI (POC) ON SHOULD BE OFF
46	2E	CPI (POC) OFF SHOULD BE ON
47	2F	LOW GAS PRESSURE SWITCH OPEN
48	30	HIGH GAS PRESSURE SWITCH OPEN
49	31	VALVE PROVE - GAS SIDE LEAK
50	32	VALVE PROVE - BURNER SIDE LEAK
51	33	OIL PRESSURE WHEN OIL PUMP OFF
52	34	LOW OIL PRESSURE WHEN PUMP RUNNING
53	35	HIGH OIL PRESSURE SWITCH OPEN
54	36	NO START RELEASE FOR OIL
55	37	NO HEAVY OIL DIRECT START
56	38	SHORTAGE OF GAS PROGRAM IN PROGRESS
57	39	PARAMETER OF MAX SAFETY TIME FAULTY
58	3A	NO BURNER ID DEFINED

Appendix - LMV5 Lockout / Error Codes (continued)

	CODE HEX	DESCRIPTION
59	3B	NO SERVICE PASSWORD DEFINED
64	40	WRONG CONTACT POSITION OF SAFETY TIME
65	41	WRONG CONTACT POSITION OF IGNITION
66	42	WRONG CONTACT POSITION OF FUEL RELAY
67	43	PLAUSIBILITY CHECK FAULT
68	44	FAULT AT DEACTIVATED INPUTS
69	45	SHUTDOWN VIA SAFETY LIMIT TEST
70	46	PROGRAM STOP ACTIVATED
71	47	START RELEASE GAS IS OFF
72	48	TWO FLAME SIGNALS WITH ONE PARAMETERIZED
80	50	FAULT DURING KEY VALUE CHECK
81	51	TIME BLOCK OVERFLOW
82	52	STACK ERROR
83	53	FAULTY RESET STATE OCCURRED
88	58	INTERNAL COMMUNICATION (uC1<>uC2)
89	59	EEPROM PAGE IS ON ABORT
90	5A	CRC ERROR OF PARAMETER RANGE
91	5B	PAGE ON ABORT
92	5C	PAGE ON WR_RESTO (BACKUP RESTORE MADE)
93	5D	PAGE OPEN TOO LONG
94	5E	PAGE HAS UNDEFINED STATUS
95	5F	LAST BACKUP RESTORE INVALID (INTERRUPTED)
96	60	FAULT COPYING A PARAMETER PAGE
97	61	FAULT WITH EEPROM INITIALIZATION
112	70	FAULT DURING RESTORING LOCKOUT INFO
113	71	MANUAL LOCKOUT VIA CONTACT
114	72	PLAUSIBILITY FAULT WITH FAULT ENTRY
128	80	WRONG STATE OF AUX3 ACTUATOR
129	81	WRONG STATE OF AIR ACTUATOR
130	82	WRONG STATE OF GAS ACTUATOR
131	83	WRONG STATE OF OIL ACTUATOR
132	84	WRONG STATE OF AUX1 ACTUATOR
133	85	WRONG STATE OF AUX2 ACTUATOR
134	86	WRONG STATE OF INTERNAL LOAD CONTROLLER
135	87	WRONG STATE OF AZL
136	88	PLAUSIBILITY FAULT (NMT)
144	90	ROM-CRC ERROR ON AUX3 FEEDBACK
145	91	ROM-CRC ERROR ON AIR FEEDBACK
146	92	ROM-CRC ERROR ON GAS FEEDBACK
147	93	ROM-CRC ERROR ON OIL FEEDBACK
148	94	ROM-CRC ERROR ON AUX1 FEEDBACK
149	95	ROM-CRC ERROR ON AUX2 FEEDBACK
150	96	ROM-CRC ERROR ON LC FEEDBACK
151	97	ROM-CRC ERROR ON AZL FEEDBACK
152	98	CANBUS DEVICE WITH SAME ADDRESS CONFLICT
153	99	CANBUS IS OFF

Appendix - LMV5 Lockout / Error Codes (continued)

CODE DECIMAL	CODE HEX	DESCRIPTION
154	9A	CANBUS WARNING LEVEL
155	9B	CANBUS QUEUE OVERRUN
160	A0	AUX3 ACTUATOR DETECTED A FAULT
161	A1	AIR ACTUATOR DETECTED A FAULT
162	A2	GAS ACTUATOR DETECTED A FAULT
163	A3	OIL ACTUATOR DETECTED A FAULT
164	A4	AUX1 ACTUATOR DETECTED A FAULT
165	A5	AUX2 ACTUATOR DETECTED A FAULT
166	A6	LOAD CONTROL DETECTED A FAULT
167	A7	AZL DETECTED A FAULT
169	A9	VSD MODULE DETECTED A FAULT
171	AB	O ₂ MODULE DETECTED A FAULT
176	B0	FAULT DURING TEST OF PORT OUTPUTS
177	B1	FAULT DURING SHORT CIRCUIT TEST
181	B5	O ₂ MONITOR FAULT
186	BA	O ₂ SENSOR TEST FAILED
191	BF	O ₂ CONTROL AUTO DEACTIVATION
197	C5	AZL HAS DETECTED OLD UNIT VERSIONS
209	D1	WRONG STATE OF VSD MODULE
211	D3	WRONG STATE OF O ₂ MODULE
225	E1	ROM-CRC ERROR ON VSD MODULE FEEDBACK
227	E3	ROM-CRC ERROR ON O ₂ MODULE FEEDBACK
240	F0	PLAUSIBILITY FAULT (INTERPOLATION)
241	F1	FAULT CALCULATING PRECONTROL
242	F2	FAULTY TEMP VALUES FROM O ₂ MODULE
87	57	INVALID PARAMETERIZATION
187	BB	O ₂ TRIM CONTROL REMOVED
190	BE	INVALID PARAMETERIZATION O ₂ CONTROL
243	F3	O ₂ TRIM CONTROL FAULT
244	F4	O ₂ MODULE FAULT (FGR)
245	F5	CANBUS FEEDBACK FAULT X60 TEMP INPUT
246	F6	FGR FAULT

Appendix - Changing Windows IP Address

If it is necessary to change to a static IP address to establish communication with the protocol converter, follow these steps.

1. Click the Windows logo to open the start menu, then type 'cmd.exe' in the *Search files and folders* text box and then press **Enter**.

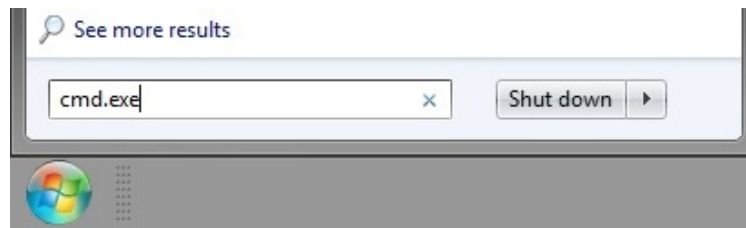

2. Type 'control ncpa.cpl' after the C:\...> prompt and then press **Enter**.



Appendix - Changing Windows IP Address (continued)

3. Right click on the network adapter that is connected to the protocol converter and then click **Properties**.

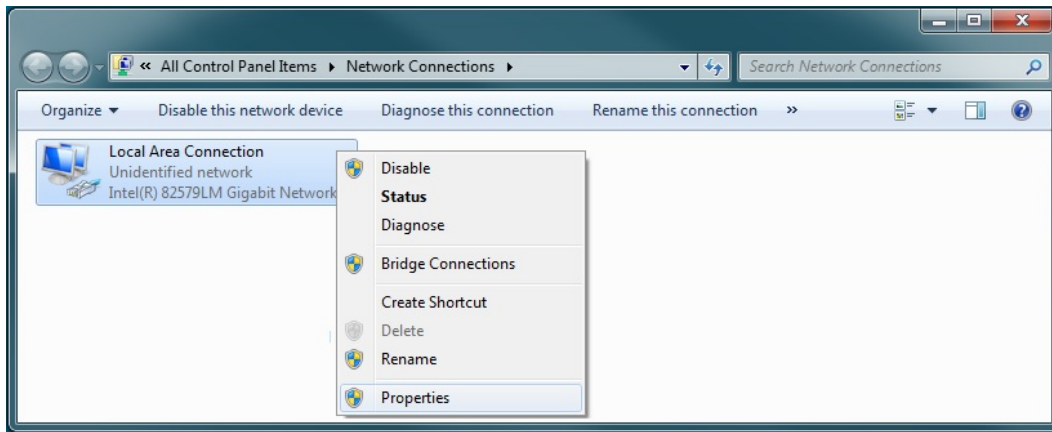

4. Click 'Internet Protocol Version 4 (TCP/IPv4)' and then click **Properties**.

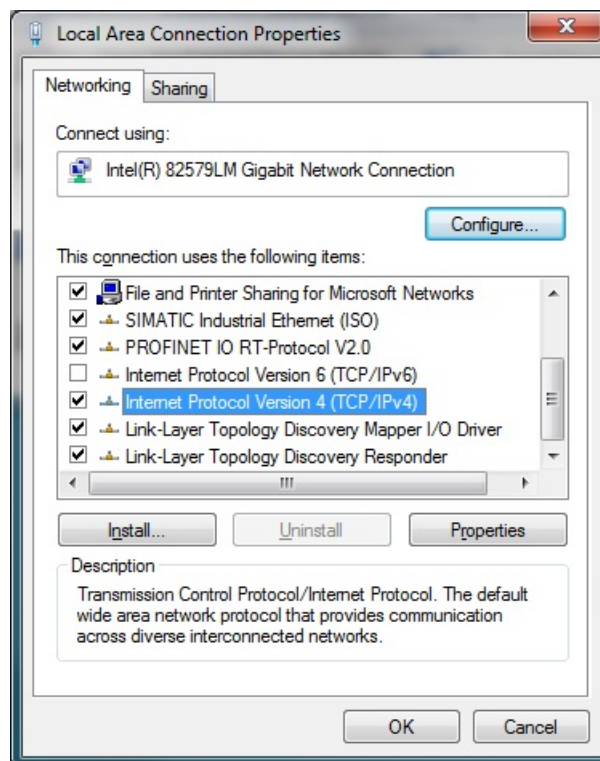

Appendix - Changing Windows IP Address (continued)

5. Click 'Use the following IP address:'. Enter the IP address and subnet mask desired. Using the values shown below is recommended if the protocol converter has the default IP address. Click **OK** on each window until the main network control panel is shown.

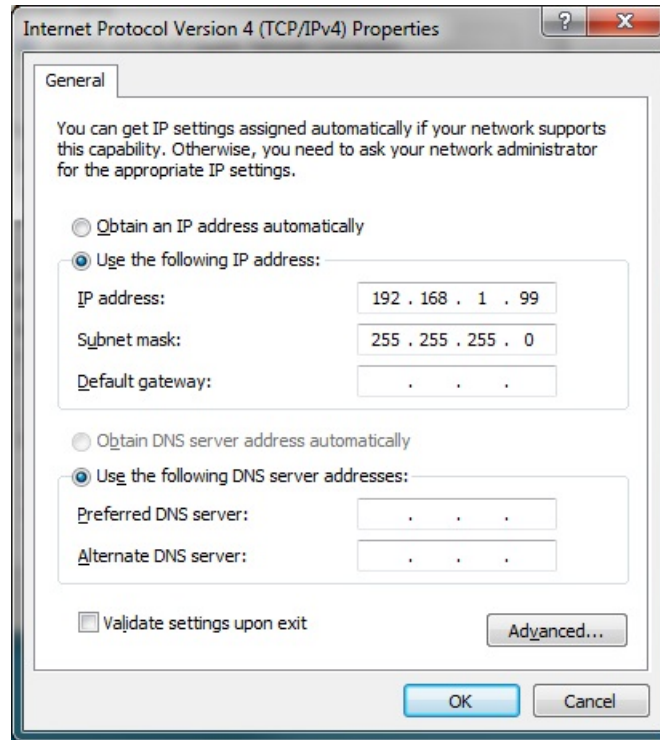

6. To restore DHCP when finished, repeat the steps shown and then click 'Obtain an IP address automatically' as well as 'Obtain DNS server address automatically' in the 'Internet Protocol Version 4 (TCP/IPv4) Properties' window.

Appendix - BACnet PICS

ANNEX A - PROTOCOL IMPLEMENTATION CONFORMANCE STATEMENT

BACnet Protocol Implementation Conformance Statement

Date: August 1, 2015

Vendor Name: Sierra Monitor Corporation

Product Name: ProtoNode

Product Model Number: ProtoNode (FPC-N3...)

BACnet Protocol Revision: Version 1 Revision 12

Product Description:

This software product will provide bi-directional communication between select Modbus/RTU and Modbus TCP/IP devices and a BACnet system. The ProtoNode can perform protocol conversion (as opposed to routing) between the different BACnet Data Link Layer options. This is arranged by way of static mappings.

BACnet Standardized Device Profile (Annex L, note ProtoNode is a gateway device):

- BACnet Operator Workstation (B-OWS)
- BACnet Advanced Operator Workstation (B-AWS)
- BACnet Operator Display (B-OD)
- BACnet Building Controller (B-BC)
- BACnet Advanced Application Controller (B-AAC)
- BACnet Application Specific Controller (B-ASC)
- BACnet Smart Sensor (B-SS)
- BACnet Smart Actuator (B-SA)

Appendix - BACnet PICS (continued)

BACnet Interoperability Building Blocks Supported (Annex K):

- K.1.1 BIBB - Data Sharing - Read Property-A (DS-RP-A)*
- K.1.2 BIBB - Data Sharing - Read Property-B (DS-RP-B)
- K.1.3 BIBB - Data Sharing - Read Property Multiple-A (DS-RPM-A)
- K.1.4 BIBB - Data Sharing - Read Property Multiple-B (DS-RPM-B)
- K.1.7 BIBB - Data Sharing - Write Property-A (DS-WP-A)
- K.1.8 BIBB - Data Sharing - Write Property -B (DS-WP-B)
- K.1.9 BIBB - Data Sharing - Write Property Multiple-A (DS-WPM-A)*
- K.1.10 BIBB - Data Sharing - Write Property Multiple-B (DS-WPM-B)
- K.1.11 BIBB - Data Sharing - COV-A (DS-COV-A)*
- K.1.12 BIBB - Data Sharing - COV-A (DS-COV-B)
- K.2.2 BIBB - Alarm and Event - Notification Internal-B (AE-N-I-B)
- K.2.5 BIBB - Alarm and Event - ACK-B (AE-ACK-B)
- K.2.11 BIBB - Alarm and Event - Information-B (AE-INFO-B)
- K.4.2 BIBB - Trending - Viewing and Modifying Trends Internal-B (T-VMT-I-B)
- K.4.5 BIBB - Trending - Automated Trend Retrieval-B (T-ATR-B)
- K.5.1 BIBB - Device Management - Dynamic Device Binding-A (DM-DDB-A)
- K.5.2 BIBB - Device Management - Dynamic Device Binding-B (DM-DDB-B)
- K.5.3 BIBB - Device Management - Dynamic Object Binding-A (DM-DOB-A)*
- K.5.4 BIBB - Device Management - Dynamic Object Binding-B (DM-DOB-B)
- K.5.6 BIBB - Device Management - Device Communication Control-B (DM-DCC-B)
- K.5.12 BIBB - Device Management - Time Synchronization-B (DM-TS-B)
- K.5.16 BIBB - Device Management - Reinitialize Device-B (DM-RD-B)
- K.5.20 BIBB - Device Management - Restart-B (DM-R-B)
- K.5.22 BIBB - Device Management - List Manipulation-B (DM-LM-B)

* Client functionality not part of B-ASC profile tested by BTL.

Segmentation Capability:

None

Appendix - BACnet PICS (continued)

Standard Object Types Supported:

Object Type	Optional Properties Supported
<ul style="list-style-type: none"> ■ Device Object 	Location Description UTC Offset Active COV Subscriptions Database Revision
<ul style="list-style-type: none"> ■ Analog Input 	Reliability Description
<ul style="list-style-type: none"> ■ Analog Output <i>Note - supported but not used</i>	Reliability Description Min Present Value Max Present Value
<ul style="list-style-type: none"> ■ Analog Value 	Reliability Description
<ul style="list-style-type: none"> ■ Binary Input 	Reliability Description Active Text Inactive Text
<ul style="list-style-type: none"> ■ Binary Output <i>Note - supported but not used</i>	Reliability Description Active Text Inactive Text
<ul style="list-style-type: none"> ■ Binary Value 	Reliability Description Active Text Inactive Text
<ul style="list-style-type: none"> ■ Multi-State Input <i>Note - supported but not used</i>	Reliability Description State Text
<ul style="list-style-type: none"> ■ Multi-State Output <i>Note - supported but not used</i>	Reliability Description State Text
<ul style="list-style-type: none"> ■ Multi-State Value <i>Note - supported but not used</i>	Reliability Description State Text
<ul style="list-style-type: none"> ■ Notification Class Object 	
<ul style="list-style-type: none"> ■ Trend Log 	Description Log Interval

Appendix - BACnet PICS (continued)

Data Link Layer Options:

- BACnet IP, (Annex J)
- BACnet IP, (Annex J), Foreign Device
- ISO 8802-3, Ethernet (Clause 7)
- ATA 878.1, 2.5 Mb. ARCNET (Clause 8)
- ATA 878.1, EIA-485 ARCNET (Clause 8)
- MS/TP master (Clause 9), baud rate(s) 9600, 19200, 38400
- MS/TP slave (Clause 9)
- Point-To-Point, EIA 232 (Clause 10)
- Point-To-Point, modem, (Clause 10)
- LonTalk, (Clause 11)
- BACnet/ZigBee (Annex O)

Device Address Binding:

Not supported

Networking Options:

- Router, Clause 6 - List all routing configurations, e.g., ARCNET-Ethernet, Ethernet-MS/TP, etc.
- Annex H, BACnet Tunneling Router over IP
- Annex H.2, Multiple Virtual BACnet Devices in a Single Physical Device
- BACnet/IP Broadcast Management Device (BBMD)
 - Does the BBMD support registrations by Foreign Devices? Yes No
 - Does the BBMD support network address translation? Yes No

Network Security Options:

- Non-secure Device - is capable of operating without BACnet Network Security
- Secure Device - is capable of using BACnet Network Security (NS-SD BIBB)
 - Multiple Application-Specific Keys:
 - Supports encryption (NS-ED BIBB)
 - Key Server (NS-KS BIBB)

Character Sets Supported:

Indicating support for multiple character sets does not imply that they can all be supported simultaneously.

- ISO 10646 (ANSI X3.4/UTF-8)
- IBM™/Microsoft™ DBCS
- ISO 8859-1
- ISO 10646 (UCS-2)
- ISO 10646 (UCS-4)
- JIS X 0208

Appendix - BACnet PICS (continued)

If this product is a communication gateway, describe the types of non-BACnet equipment/networks(s) that the gateway supports:

Modbus/RTU

Modbus TCP/IP

Metasys N2

LonWorks

Information in this publication is based on current specifications. The company reserves the right to make changes in specifications and models as design improvements are introduced. Product or company names mentioned herein may be the trademarks of their respective owners. © 2015 SCC Inc.