

## TS Series

### TS-CE... Combustion Enclosures with LMV3...



### Description

TS-CE... series combustion enclosure with Siemens LMV3 linkageless controller sets the new standard for combustion control and monitoring technologies. The preprogrammed touchscreen and optional PLC annunciation packages provide monitoring and control for any burner/boiler installation with excellent control capability, configuration flexibility, and simple connectivity to an SCC Master Lead/Lag panel. The TS-CE... combustion enclosure provides easy installation.

The TS-CE... combustion control panels with LMVs provide a common centralized center to monitor and retrieve information, resulting in efficient operation of the burner.

All burner flame safeguard and combustion safety control is performed by the advanced Siemens linkageless controller.

Touchscreen options include Modbus TCP/IP communication to a separate master lead/lag panel, or to a third party BMS as standard with touchscreens. Optional capability to communicate with building management systems is available via Modbus RTU, RS232 or RS485 connections, Johnson Metasys N2, BACnet MSTP or BACnet IP, LonWorks, ProfiNet, and Profibus.

---

## Features

TS-CE... combustion enclosure with LMV3 is UL 508 listed and includes the following:

- 6" or 10" touchscreen option
- LMV36 or LMV37 Siemens linkageless control and flame safeguard
- Backlit AZL23 display
- Control of up to two (2) SQM33 actuators for single fuel applications
- Control of up to three (3) SQM33 actuators for dual fuel applications
- Programmable logic controller (PLC)
- Steam or hot water boiler control
- Flame supervision and flame strength monitoring
- UV scanner
- Single or dual fuel
- Oil pump control
- Blower motor control
- Atomizing compressor control
- Lead/lag ready with SCC TS... master lead/lag panel
- VSD control
- Blower motor sensor for motor RPM monitoring
- Low fire hold based on temperature
- Shell water temperature monitoring
- External and proven interlocks
- Actuator position display
- LMV3 fault history
- Burner operating phase display
- Local touchscreen interface with Siemens LMV.../RWF controllers
- Configurable boiler graphics and field tag information
- LMV... static, fuel, and error history displayed
- Fuel-Air Ratio control curve displayed on touchscreen
- Alarm history for most recent 250 faults/alarms
- Detailed annunciation of LMV... digital inputs and outputs
- Remote setpoint, firing rate, and/or enable of the LMV... or RWF... via BMS
- Water level control option and status via RWF55
- Metric or Standard units display
- English or Spanish languages
- Clear English or Spanish text for alarms

- 
- Circulating pump, isolation valve control outputs for hydronic boilers (option with expanded annunciator)
  - Expanded annunciator options include:
    - Four (4) analog inputs with field configurable label, span, and type (0-10V, 2-10V, 0-20mA, or 4-20mA). Each allows low and high alarm setpoints, with auto or manual reset. Totalization available per minute or per hour.
    - Four (4) Pt1000 (or Pt100) RTD temperature inputs with field configurable label. Each allows low and high alarm setpoints with auto or manual reset.
    - Two (2) analog outputs with field configurable span and type (0-10V, 2-10V, 0-20mA, or 4-20mA). Each allows low and high alarm setpoints, with auto or manual reset. Totalization available per minute or per hour.
    - Two (2) digital outputs with field configurable logic, including on and off delays. Manual or automatic reset.
    - First-out annunciation option including thirteen (13) 120 VAC inputs with field labeling capability.
    - Eight (8) selectable data logging variables stored in CSV format on USB drive.
    - Four (4) selectable variables for trending up to 7 days.
    - Economizer temperature monitoring .
    - Draft control with SQM5 actuator.
    - Connection for two additional RWF55 controllers.
  - Screen saver with PV, setpoint, demand, and status
  - Standard Modbus TCP/IP to BMS communications
  - Additional BMS communication options available
  - Email communications and text messaging for up to six (6) recipients include alarms, faults, and screen shots (screen shot viewer via USB)
  - Remote monitoring via smartphone or tablet
  - Compatible with SCC Master Panel Lead/Lag system

---

## Application

TS-CE...combustion enclosure panel with LMV3 systems are suited for hot water and steam boilers, with up to 88.5 in/lbs of actuator torque, for single or dual fuel applications.

---

## Standard Components

- LMV3 linkageless parallel positioning flame safeguard
- Power fail relay
- System alarm
- Circuit breaker, 3 Amp, single pole
- Circuit breaker, 10 Amp, single pole
- Non-fused disconnect switch
- Burner ON/OFF switch
- Three position fuel selector switch
- Safety limits powered, white indicator light
- Safety limits complete, green indicator light
- Pilot burner ON, yellow indicator light
- Gas valve open, blue indicator light
- Oil valve open, yellow indicator light
- Power fail, red illuminated indicator light with reset push button
- Low water, red illuminated indicator light with reset push button
- LMV error, red illuminated indicator light with reset push button
- Alarm reset push button
- Alarm horn
- Gray terminals, general
- White terminals, 120 VAC neutral
- Black terminals, 120 VAC hot
- Red terminals, 24 VDC +
- Blue terminals, 24 VDC -
- Orange terminals, 24 VAC
- Yellow terminals, dry contact powered from second source
- Green, non-grounding, shield terminals
- Green/Yellow PE terminals

---

## Optional Components

- 6" or 10" touchscreen
- Programmable Logic Controller with additional annunciation inputs
- LWCO manual and auto reset Warrick relays for probe type level control
- Draft control with Siemens SQM5 actuator only
- NEMA 12 or NEMA 4
- Additional external load or water level controllers
- BMS communication options
- Three phase option includes:
  - Main three phase fused disconnect 30Amps/60Amps/100Amps
  - VSD three phase fuses and fuse holders
  - Blower motor starter for up to 20hp with overload and built in disconnect
  - Oil motor starter for up to 10hp with overload and built in disconnect
  - Compressor motor starter for up to 20hp with overload and built in disconnect
  - 1000 VA circuit control transformer
  - Fan air cooling
- Deaerator/Surge control panels, (See TS-3000)
- Master Lead/Lag control panels, (See TS-2000)

## Product Part Numbers

	TS	-	CE	6	3	-	0	-	X	4	S	-	1	3	-	X	X	X	X
<b>Touchscreen</b>																			
<b>Combustion Enclosure</b>																			
<b>LMV Model</b>																			
	6 = LMV36.520A1 (Single Fuel) 7 = LMV37.420A1 (Single Fuel) D = LMV36.520A1 with AGM60 (Dual Fuel)																		
<b>Load Controller (LC) or Water Level (WL)</b>																			
	1 = RWF50.30A9 load controller (LC) 3 = RWF55.50A9 load controller (LC) 6 = Two (2) RWF55.50A9 LC/WL Controllers and SKB/C/D Transformer																		
<b>Touchscreen</b>																			
	X = No Touchscreen N = No touchscreen 6 = 6" Schneider Touchscreen 0 = 10" Schneider Touchscreen																		
<b>Draft Control</b>																			
	X = No Draft Control D = Draft control with annunciation option 5 E = Draft control with annunciation option 8																		
<b>Annunciation (Touchscreen selection required)</b>																			
	X = No PLC and annunciation inputs 1 = Standard annunciation, 13 120VAC inputs 2 = 13 120 VAC annunciation inputs and 4 analog inputs 3 = 13 120 VAC annunciation inputs and 4 RTD 100/1000 Ω inputs 4 = 13 120 VAC annunciation inputs and 4 RTD 100/1000 Ω inputs dedicated for economizer 5 = 13 120 VAC annunciation inputs, 4 analog inputs, and 4 RTD 100/1000 Ω inputs 6 = 13 120 VAC annunciation inputs, 4 analog inputs, and 4 100/1000 Ω inputs dedicated for economizer 7 = 13 120 VAC annunciation inputs, 4 RTD 100/1000 Ω inputs, and 4 RTD 100/1000 Ω inputs dedicated for economizer 8 = 13 120 VAC annunciation inputs, 4 analog inputs, 4 RTD 100/1000 Ω inputs, and 4 RTD 100/1000 Ω inputs dedicated for economizer																		
<b>BMS Communication</b>																			
	X = Modbus RTU RS485 with the OCI 412 S = Standard Modbus TCP/IP with touchscreen B = BACnet /IP L = LonWorks M = N2 Johnson Metasys or BACnet MS/TP N = ProfiNet P = Profibus R = Modbus RTU with touchscreen option																		
<b>Enclosure</b>																			
	1 = NEMA 1 2 = NEMA 12, includes cover over touchscreen and AZL/RWF (if applicable) 4 = NEMA 4X (indoor), includes cover over AZL/RWF (if applicable) A = NEMA 1 with cooling fan B = NEMA 12 with cooling fan, includes cover over touchscreen and AZL/RWF and fan (if applicable) C = NEMA 4X with cooling fan, includes cover over touchscreen and AZL/RWF and fan (if applicable)																		
<b>Warrick Relays</b>																			
	X = None 1 = One manual reset Warrick relay mounted in enclosure 2 = One auto reset Warrick relay mounted in enclosure 3 = One auto and one manual reset Warrick relay mounted in enclosure A = One manual reset Warrick relay shipped loose B = One auto reset Warrick relay shipped loose C = One manual and one auto reset Warrick relay shipped loose																		
<b>Voltage 3 Phase</b>																			
	X = 110-120 VAC, Internal 3 Phase not included 4 = 440 - 480 VAC																		
<b>Blower Motor Horse Power Starter or VSD Control (480VAC)</b>																			
	X = Internal 3 phase not included C = Blower motor starter for 3hp E = Blower motor starter for 5hp G = Blower motor starter for 7.5hp J = Blower motor starter for 10hp O = Blower motor starter for 15hp T = Blower motor starter for 20hp									X = Internal 3 phase not included 2 = Connections for blower motor VSD 3hp 3 = Connections for blower motor VSD 5hp 4 = Connections for blower motor VSD 7.5hp 5 = Connections for blower motor VSD 10hp 6 = Connections for blower motor VSD 15hp 7 = Connections for blower motor VSD 20hp									
<b>Oil Pump Starter Horse Power (480VAC)</b>																			
	X = Internal 3 phase not included A = Oil pump motor starter for 1hp B = Oil pump motor starter for 1.5hp C = Oil pump motor starter for 2hp D = Oil pump motor starter for 3hp									E = Oil pump motor starter for 5hp G = Oil pump motor starter for 7.5hp J = Oil pump motor starter for 10hp									
<b>Air Compressor Pump Starter Horse Power (480VAC)</b>																			
	X = Internal 3 phase not included C = Compressor motor starter for 3hp E = Compressor motor starter for 5hp G = Compressor motor starter for 7.5hp									J = Compressor motor starter for 10hp O = Compressor motor starter for 15hp T = Compressor motor starter for 20hp									

**Specifications without 3 Phase Power**

		<b>With Touchscreen</b>	<b>W/out Touchscreen</b>
Electrical characteristics	Main power	120 VAC	120 VAC
	Component power	24 VDC/VAC	120 VAC
	Power consumption	≤ 960 VA	≤ 740 VA
Operating environment	Operating temperature	32 to 122 °F [0 to 50 °C]	-4 to 140 °F [-20 to 60 °C]
	Humidity	Max. 85% with no condensation	Max. 85% with no condensation

**Specifications with 3 Phase Power**

		<b>With Touchscreen</b>	<b>W/out Touchscreen</b>
Electrical characteristics	Main power	480 VAC	480 VAC
	Current	≤ 70 Amps	≤ 70 Amps
	Component power	24 VDC/120 VAC	120 VAC
	Power consumption	≤ 27.6 kVA	≤ 27.6 kVA
Operating environment	Operating temperature	32 to 122 °F [0 to 50 °C]	-4 to 140 °F [-20 to 60 °C]
	Humidity	Max. 85% with no condensation	Max. 85% with no condensation

## Field Connections

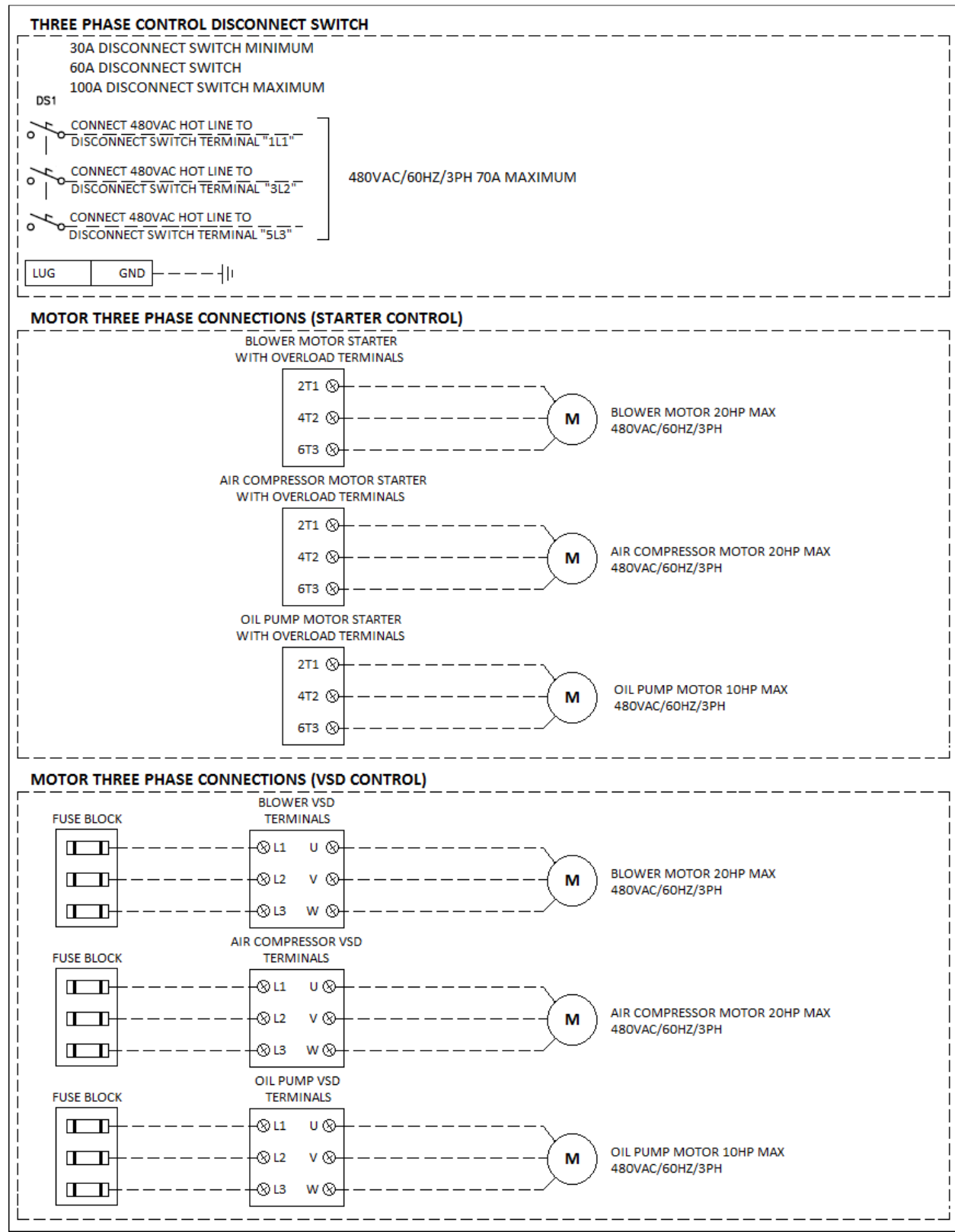

## Field Connections (continued)

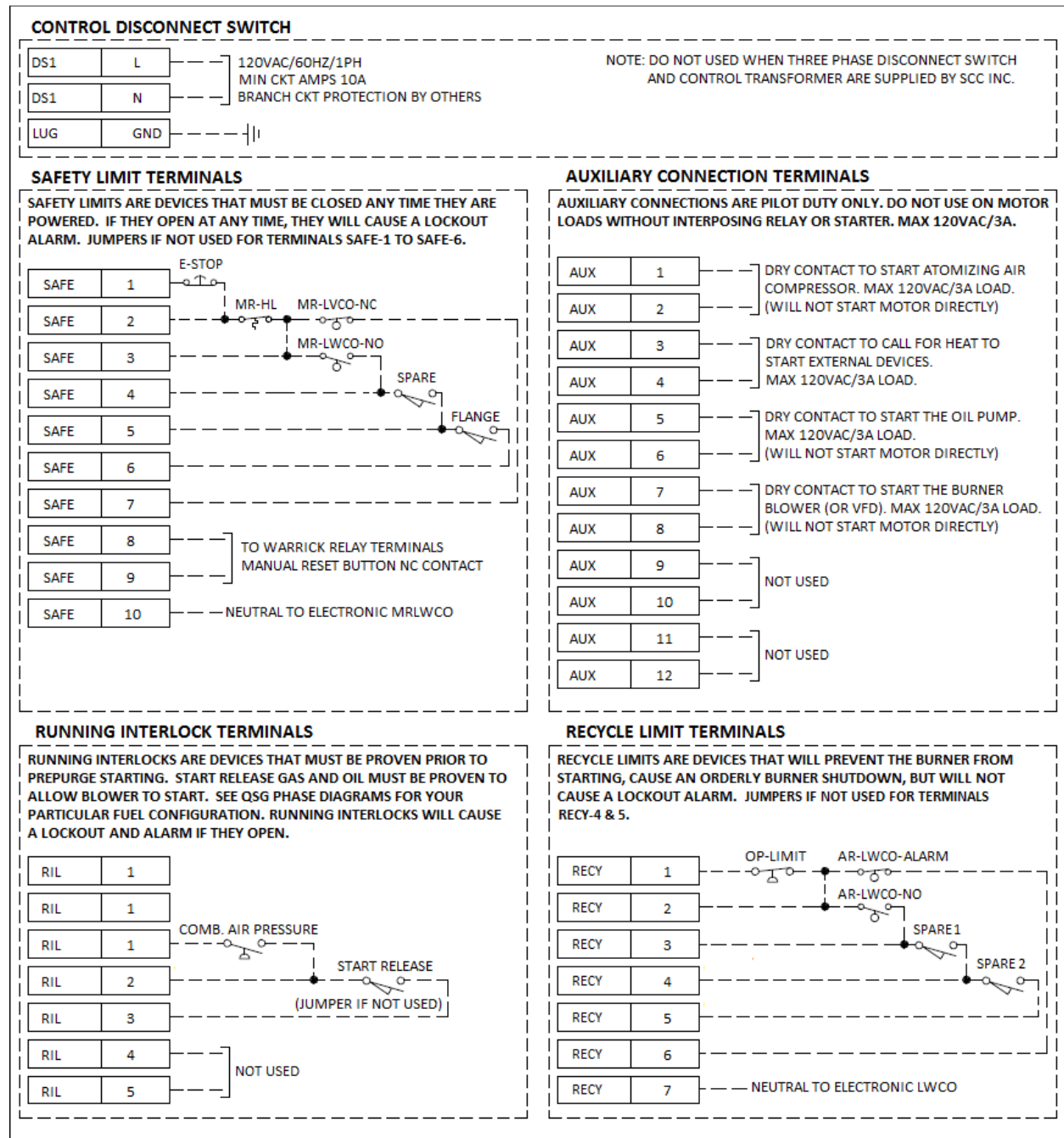

## Field Connections (continued)

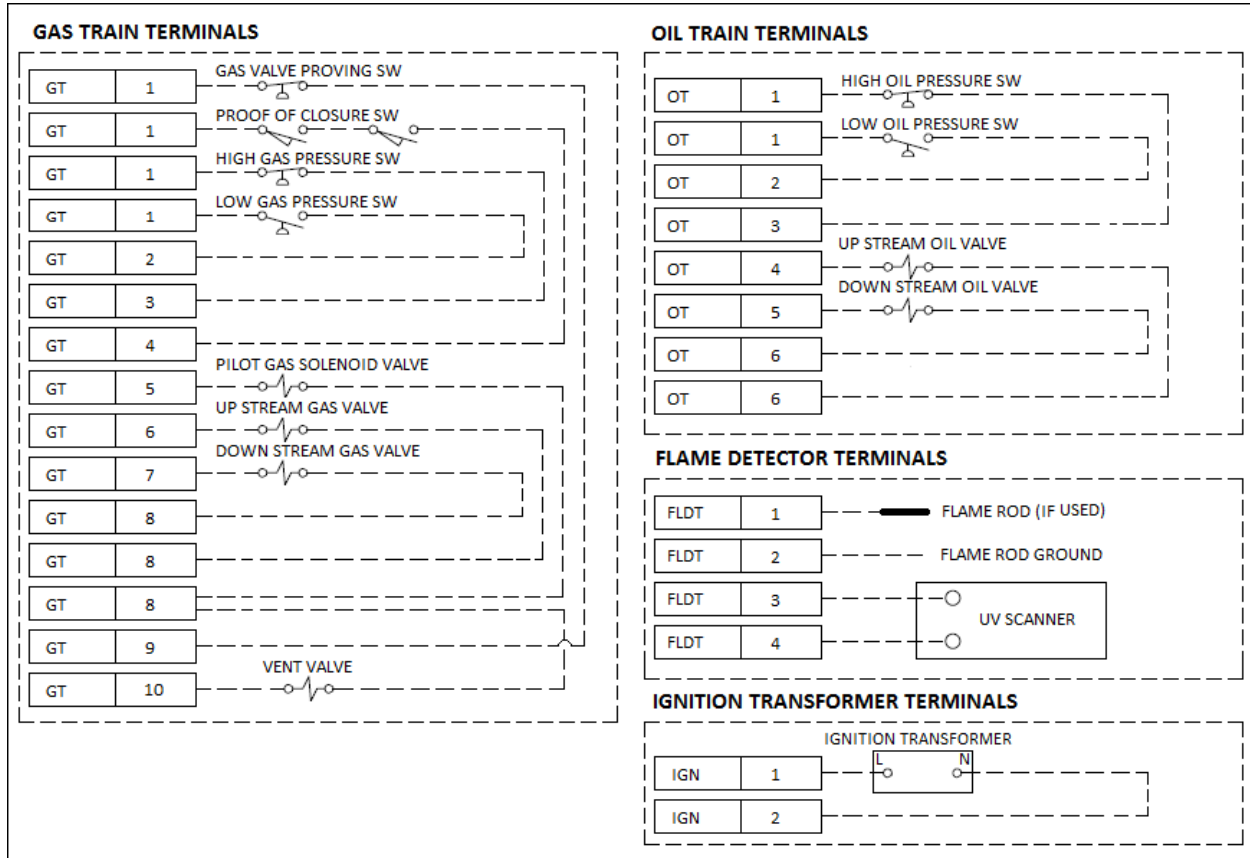

## Field Connections (continued)

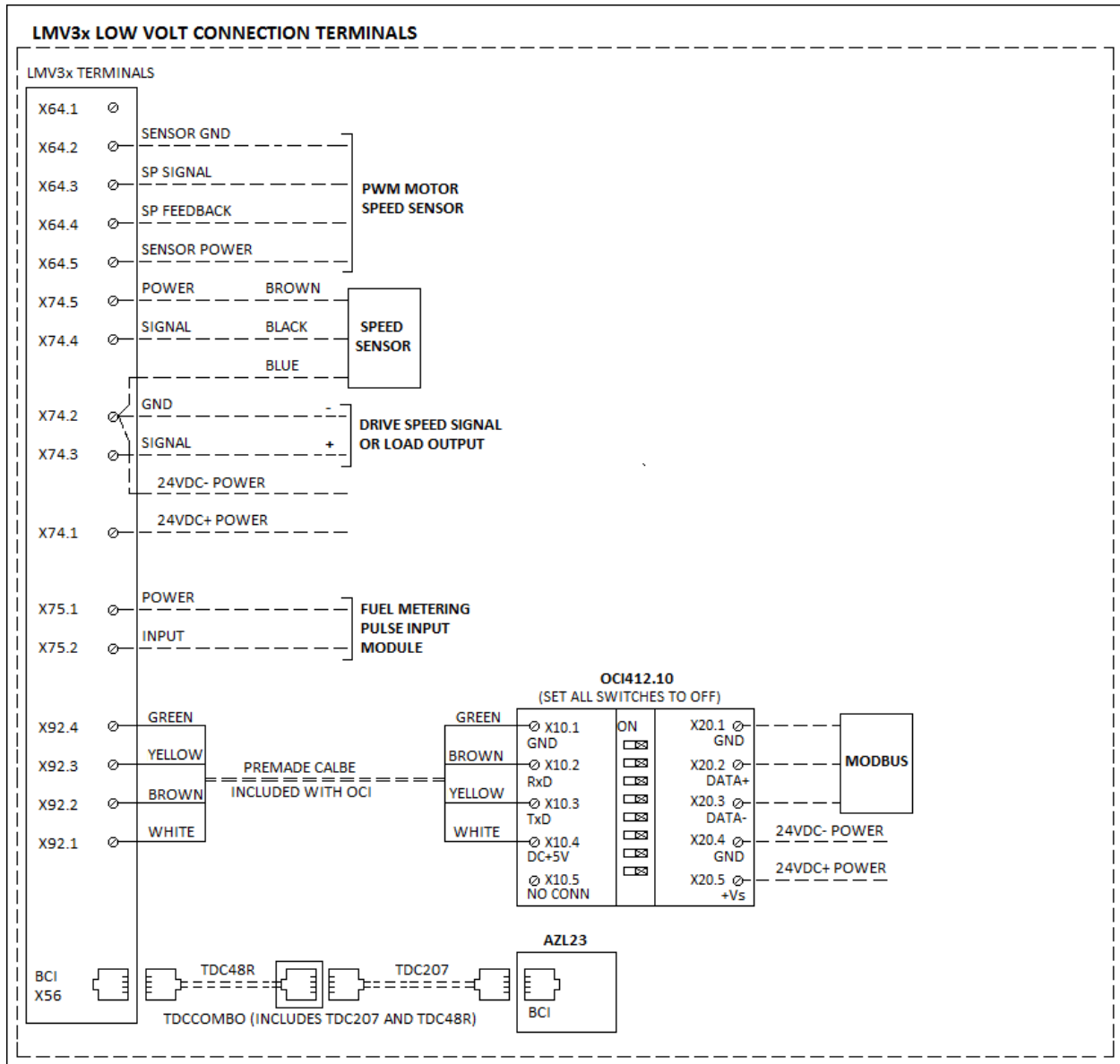

## Field Connections (continued)

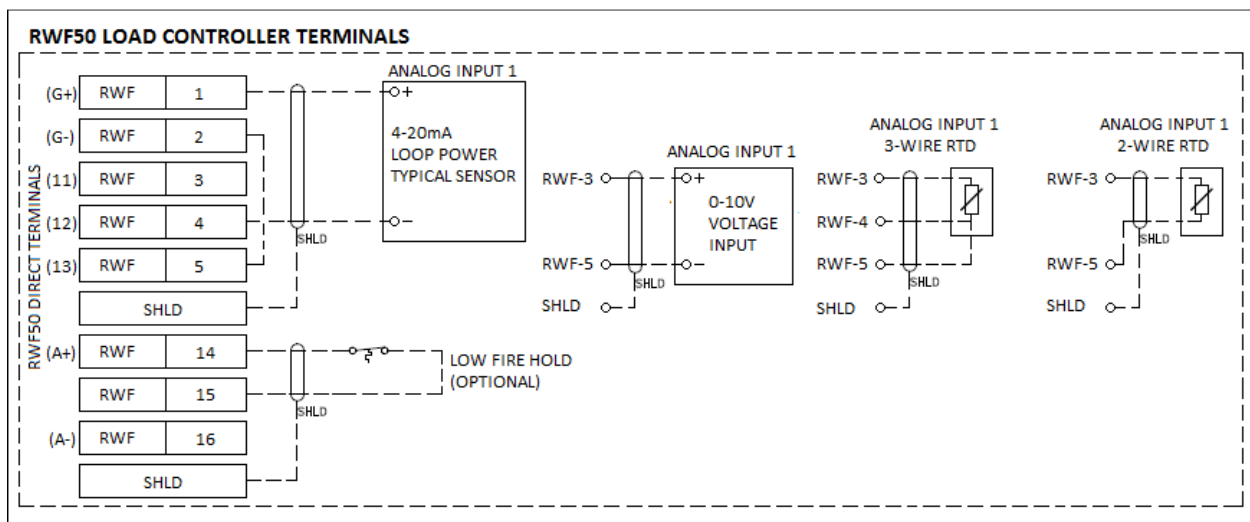
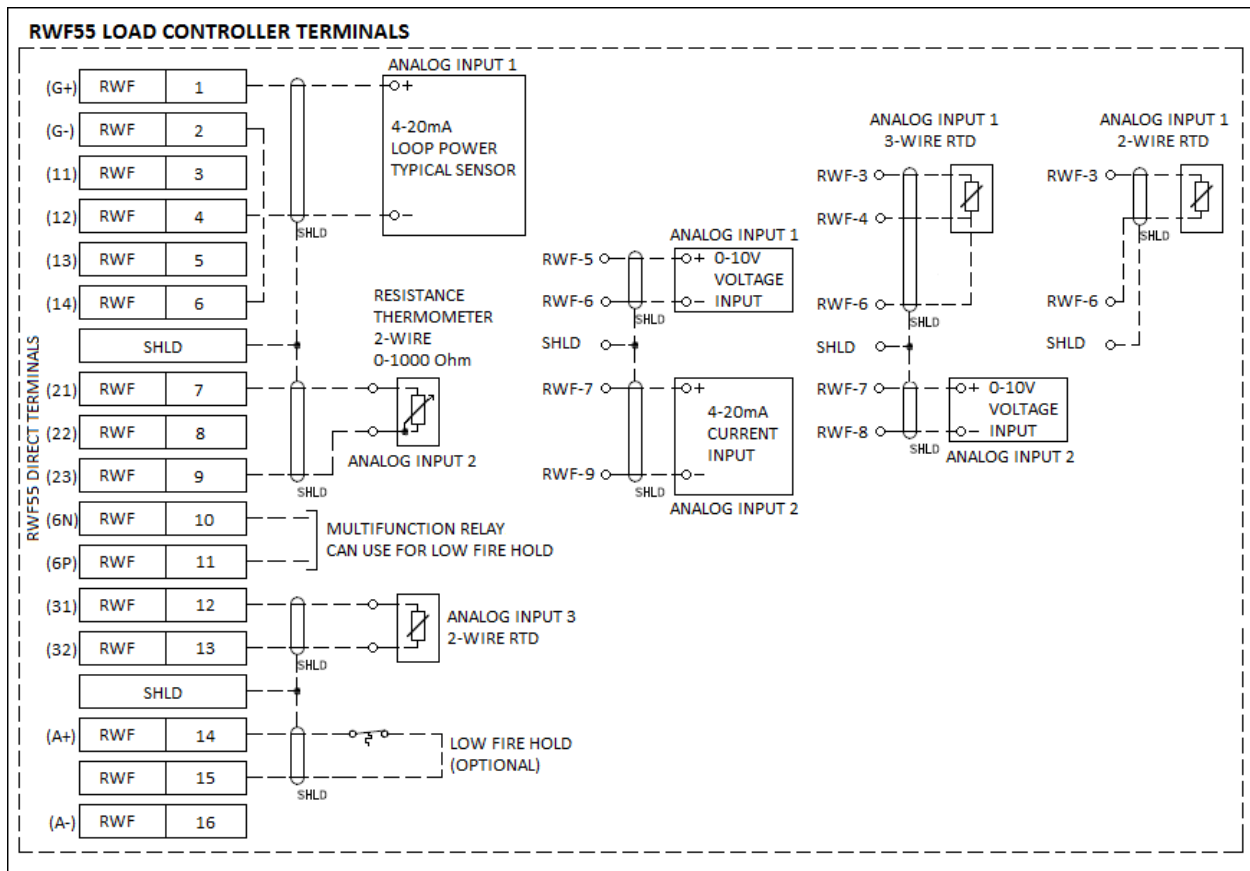

## Field Connections (continued)

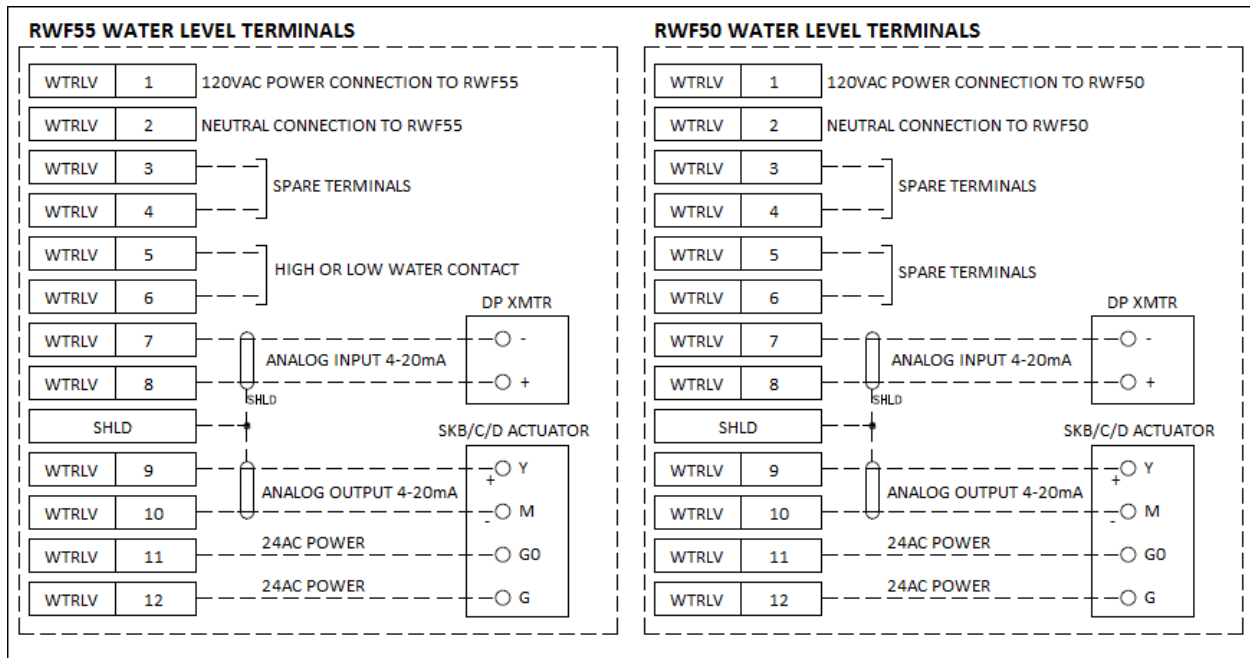
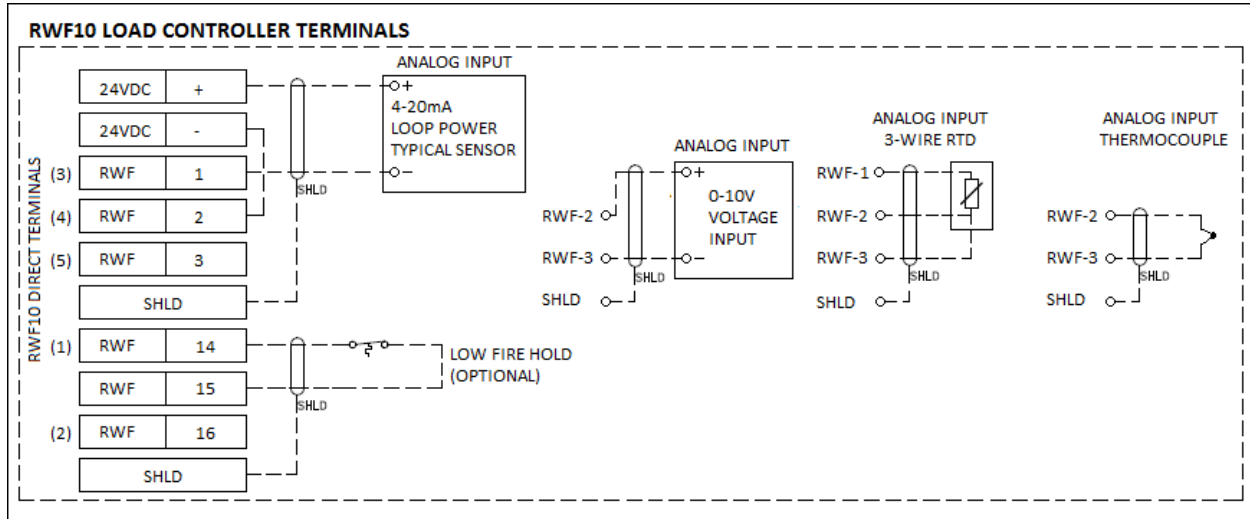

## Field Connections (continued)

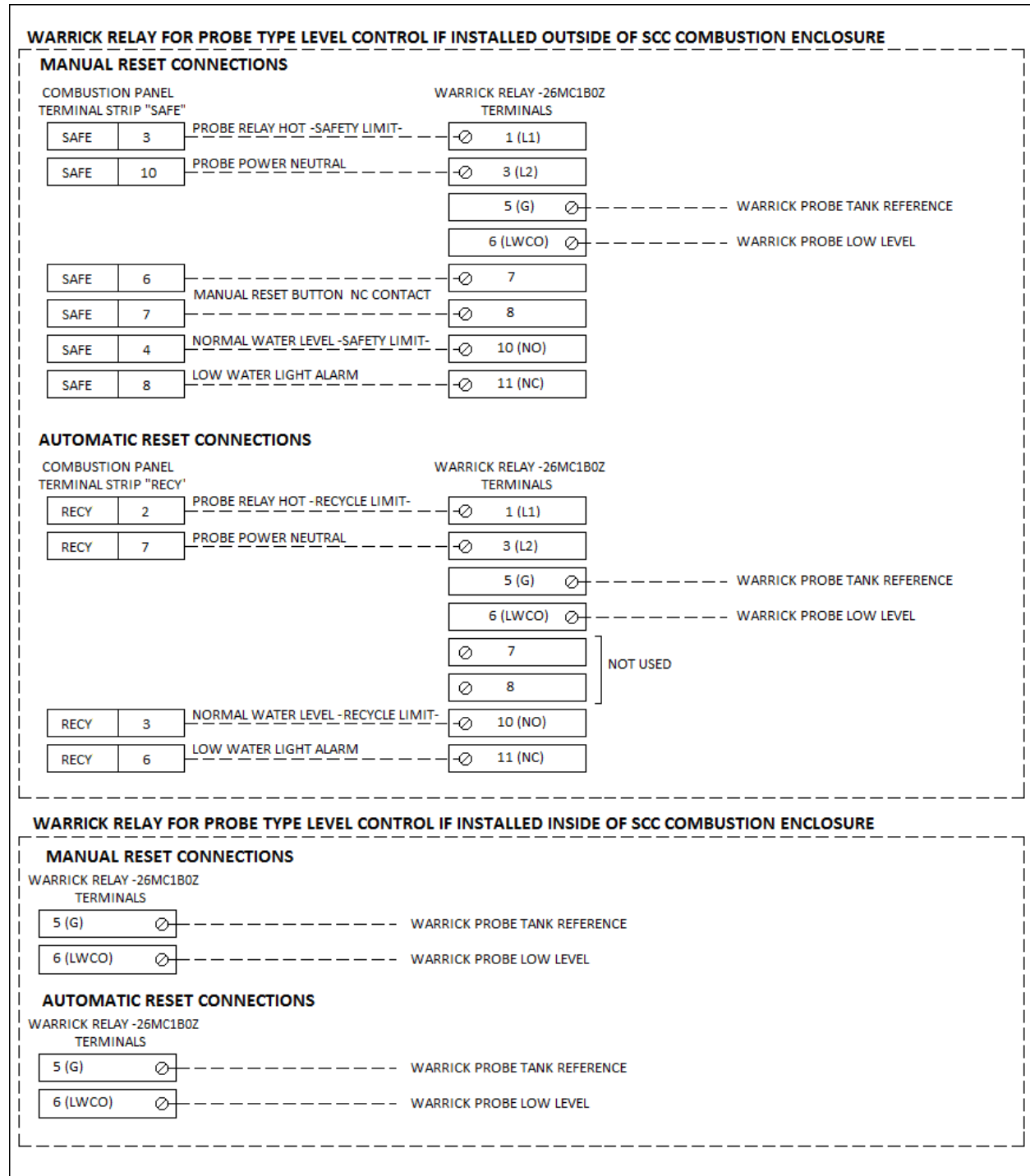

## Field Connections (continued)

Standard annunciation thirteen 120VAC inputs:

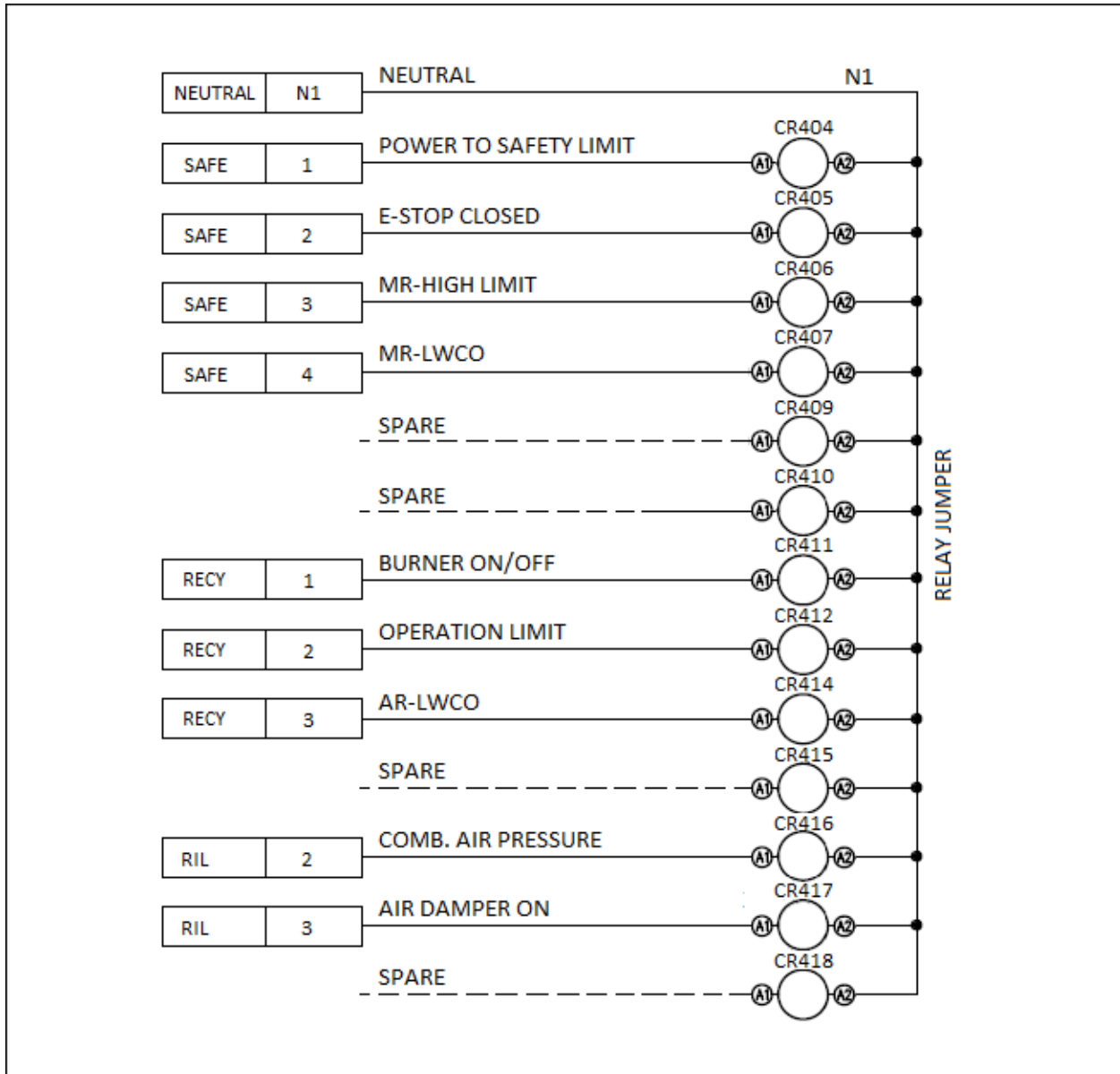

## Field Connections (continued)

Standard annunciation thirteen (13) 120 VAC Inputs (with draft control):

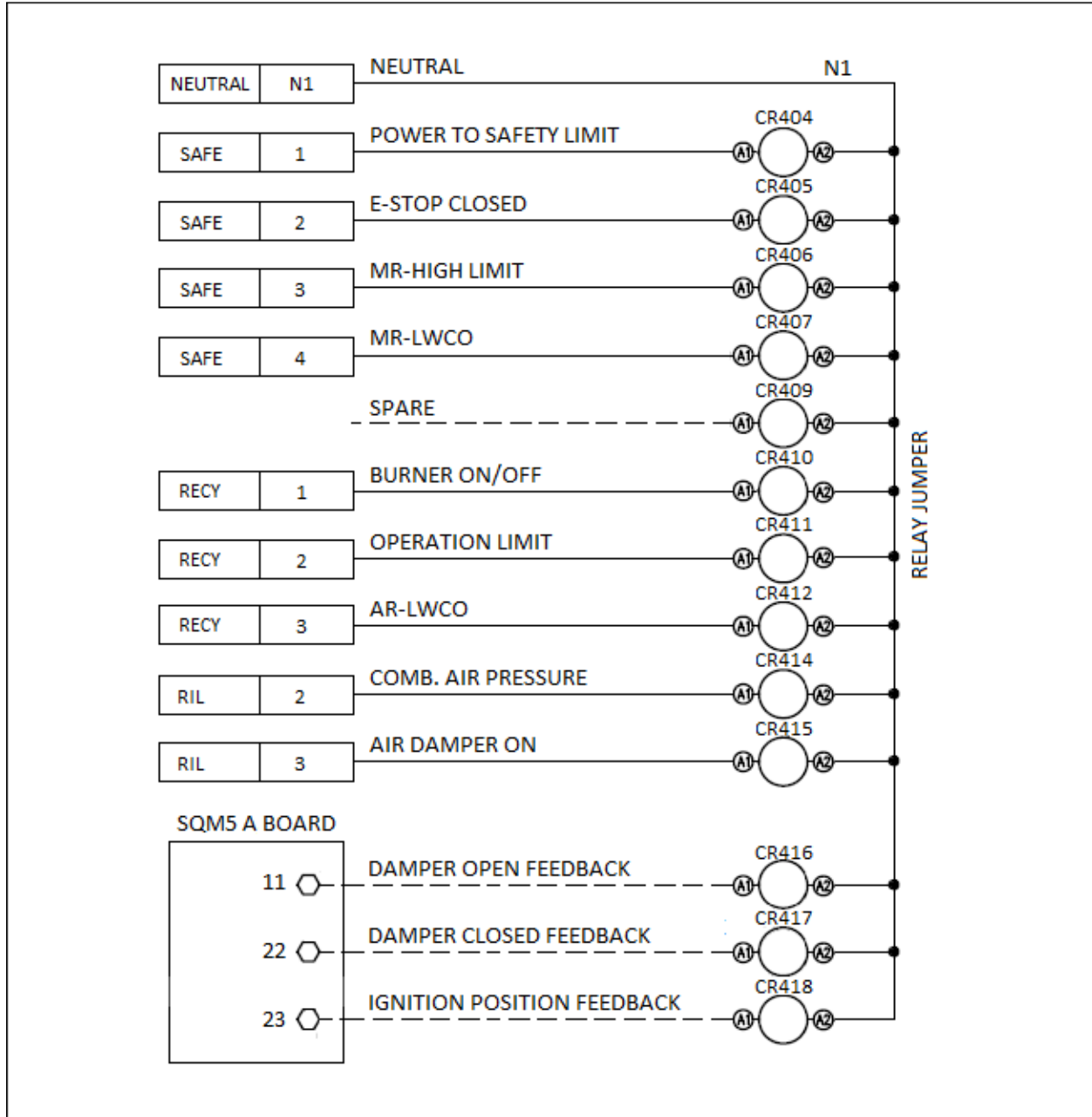

## Field Connections (continued)

Pump proven input terminals:

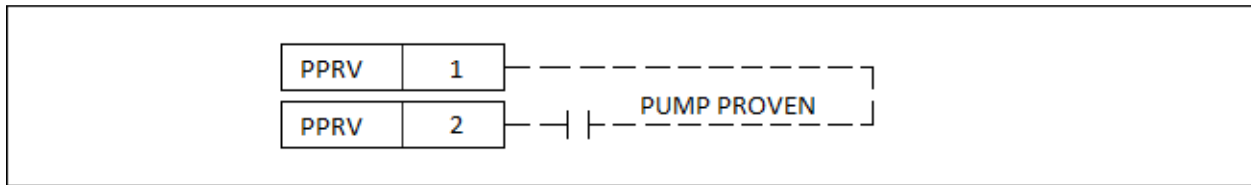

Output terminals, circulating pump (hot water boilers only), and monitored values:

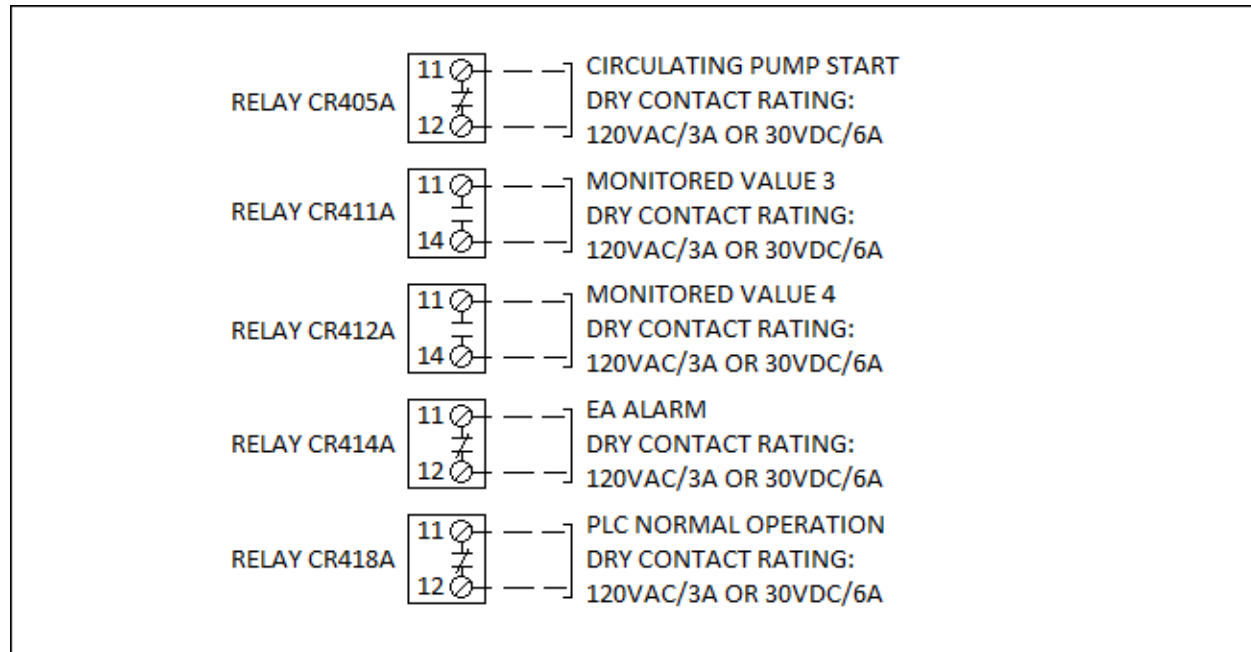

Up to two (2) additional Modbus Serial RS485 connections for RWF55 loop controllers:

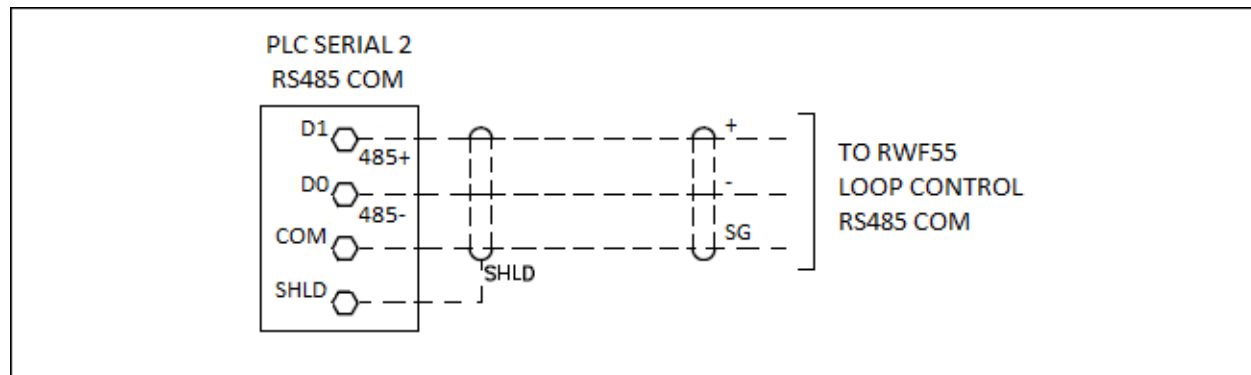

## Field Connections (continued)

Analog input terminals (no draft control):

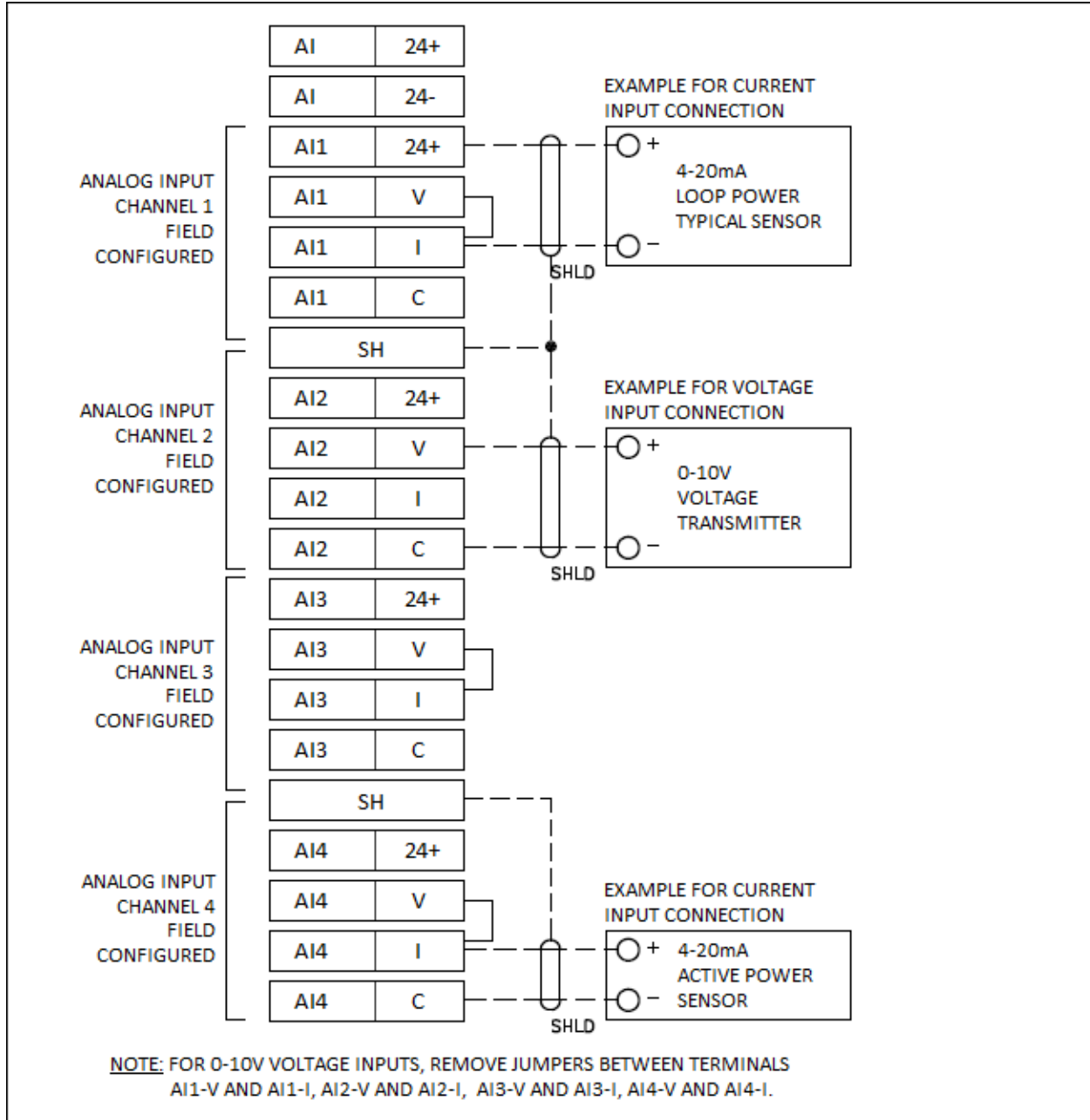

## Field Connections (continued)

Analog output terminals:

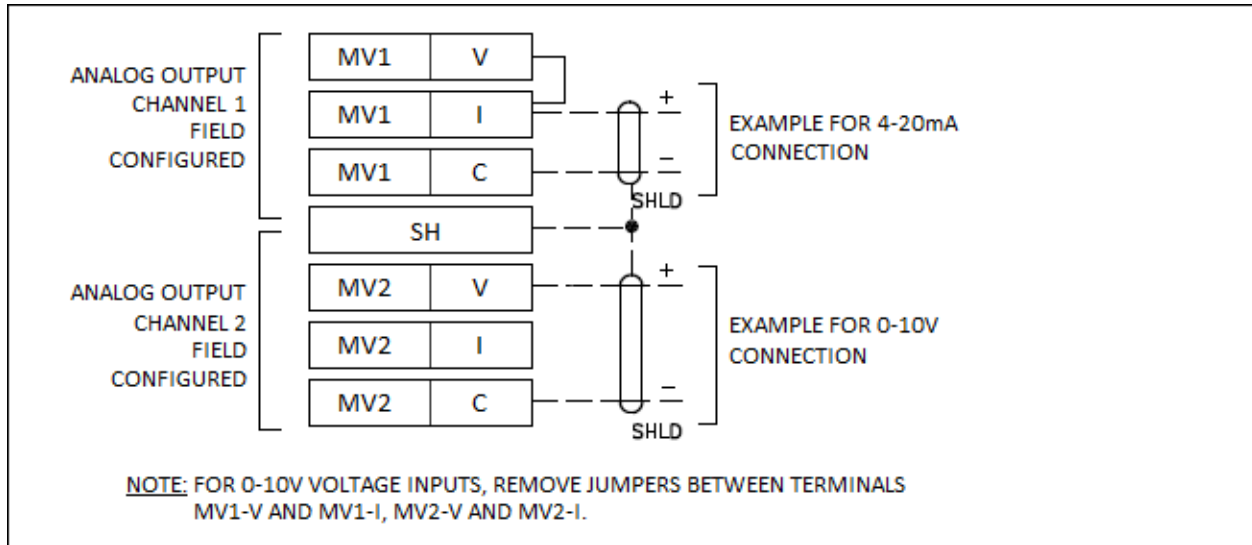

## Field Connections (continued)

Analog input terminals (with draft control):

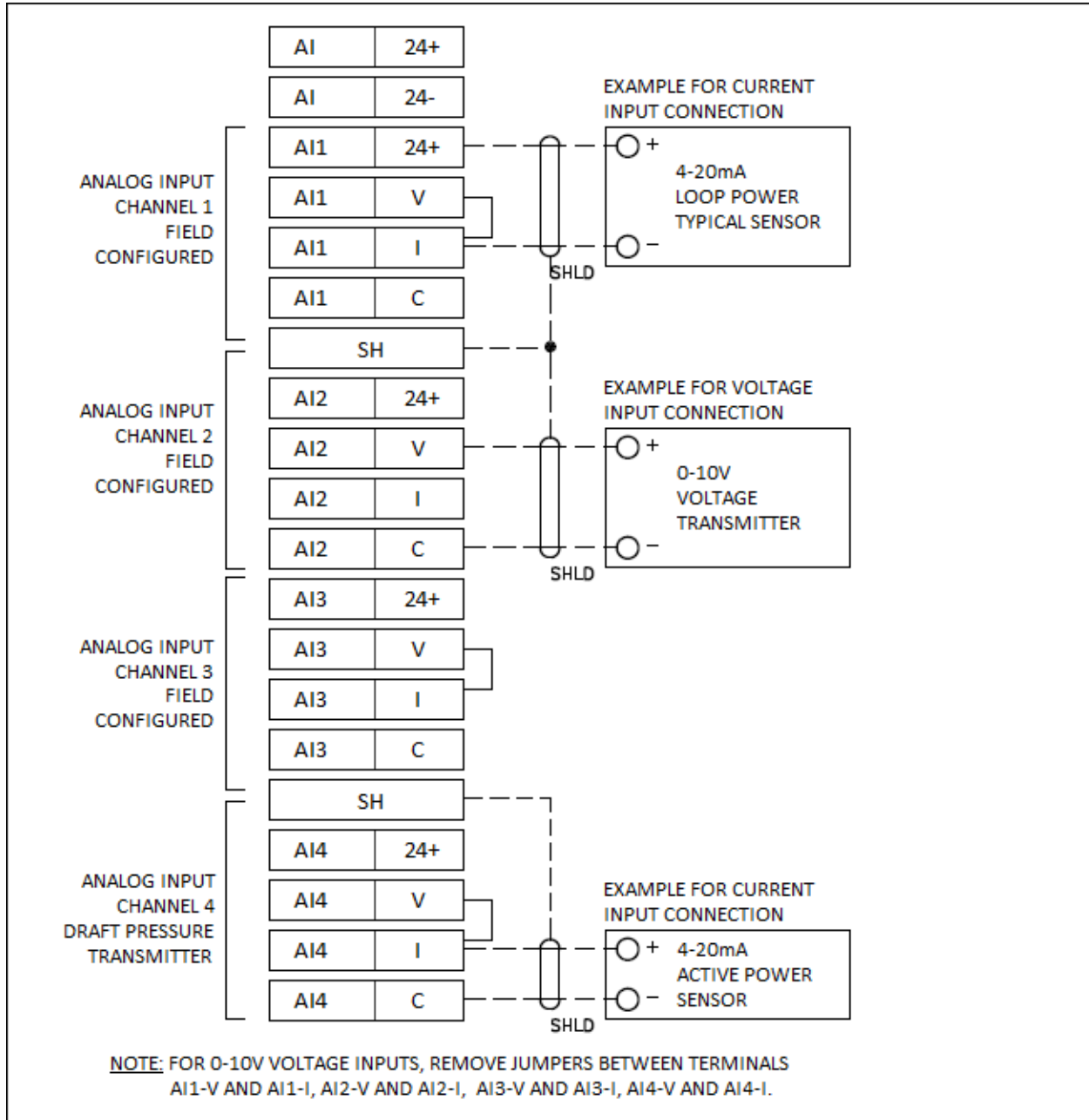

## Field Connections (continued)

RTD 100/1000 Ω input terminals (no draft control):

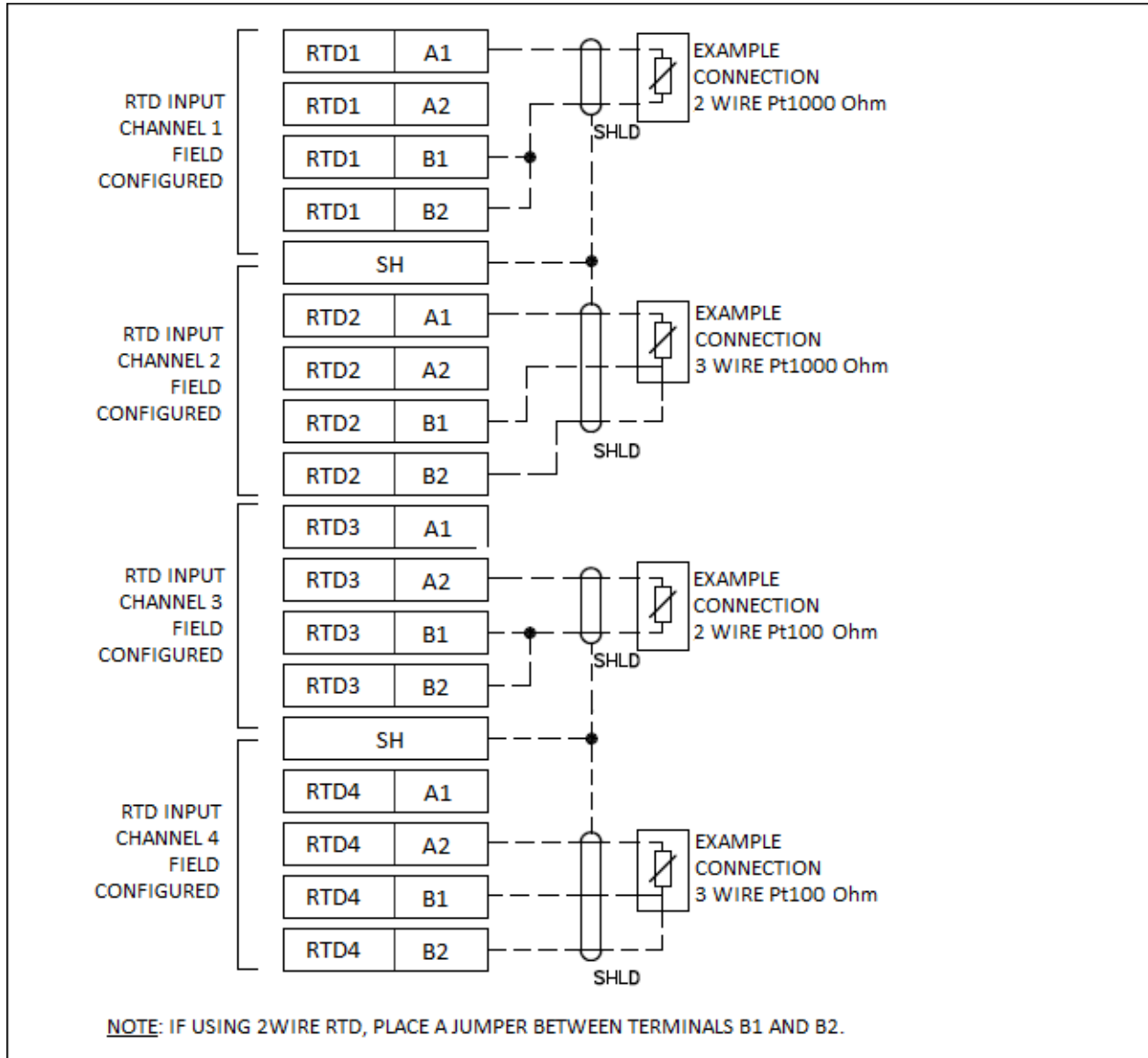

## Field Connections (continued)

RTD 100/1000  $\Omega$  input terminals (with draft control):

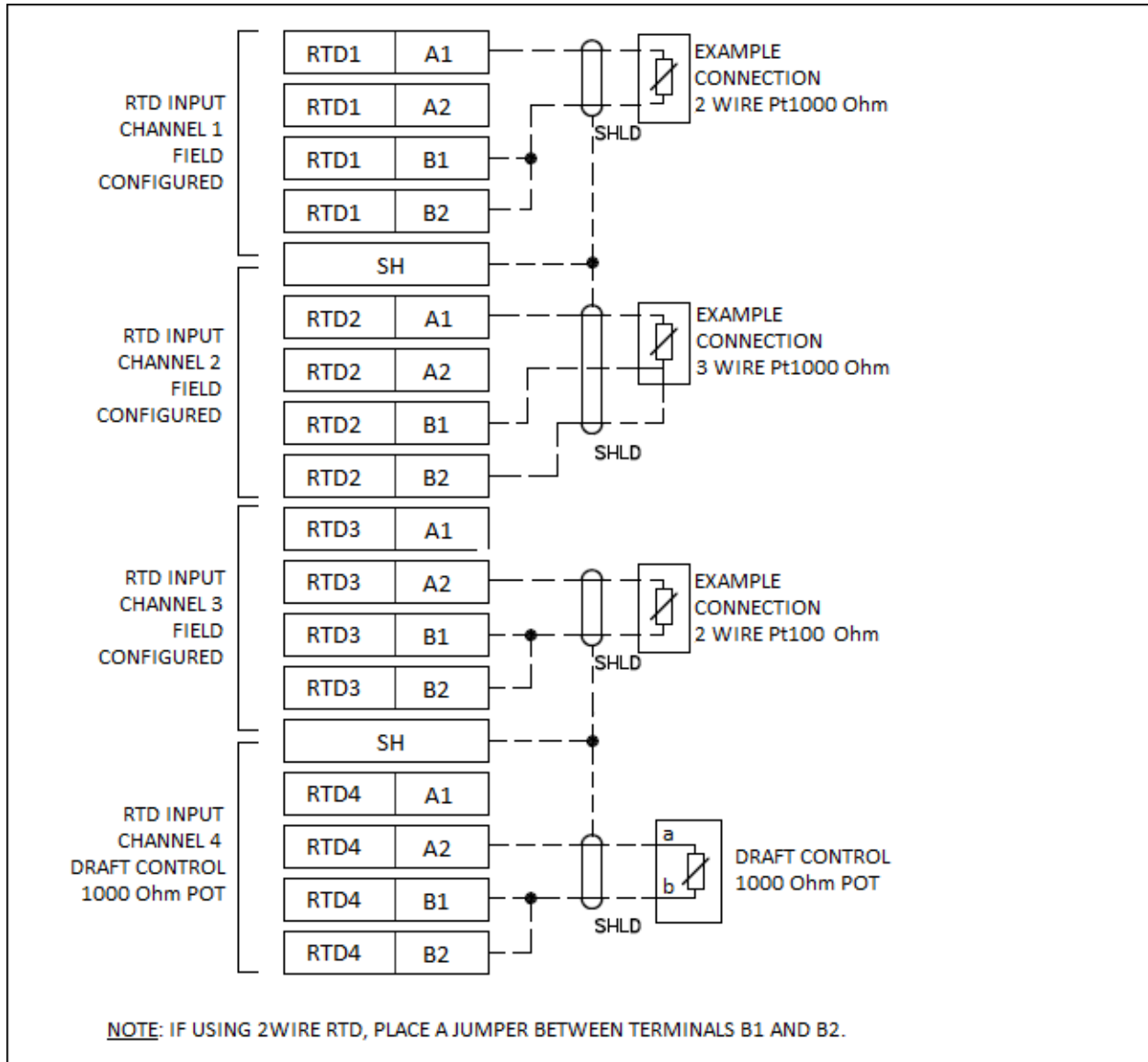

## Field Connections (continued)

RTD 100/1000 Ω input terminals for economizer:

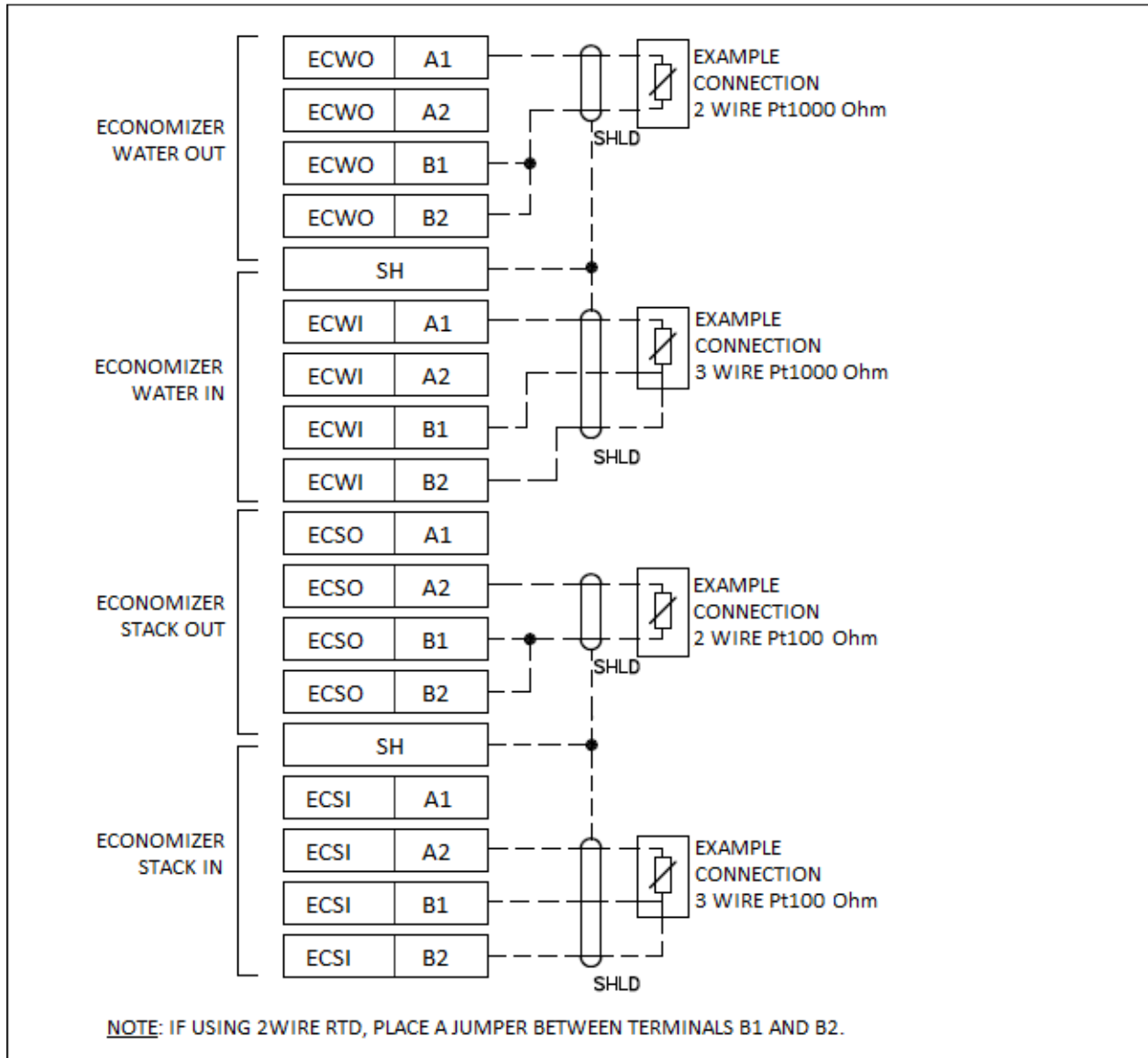

## Field Connections (continued)

Draft Control:

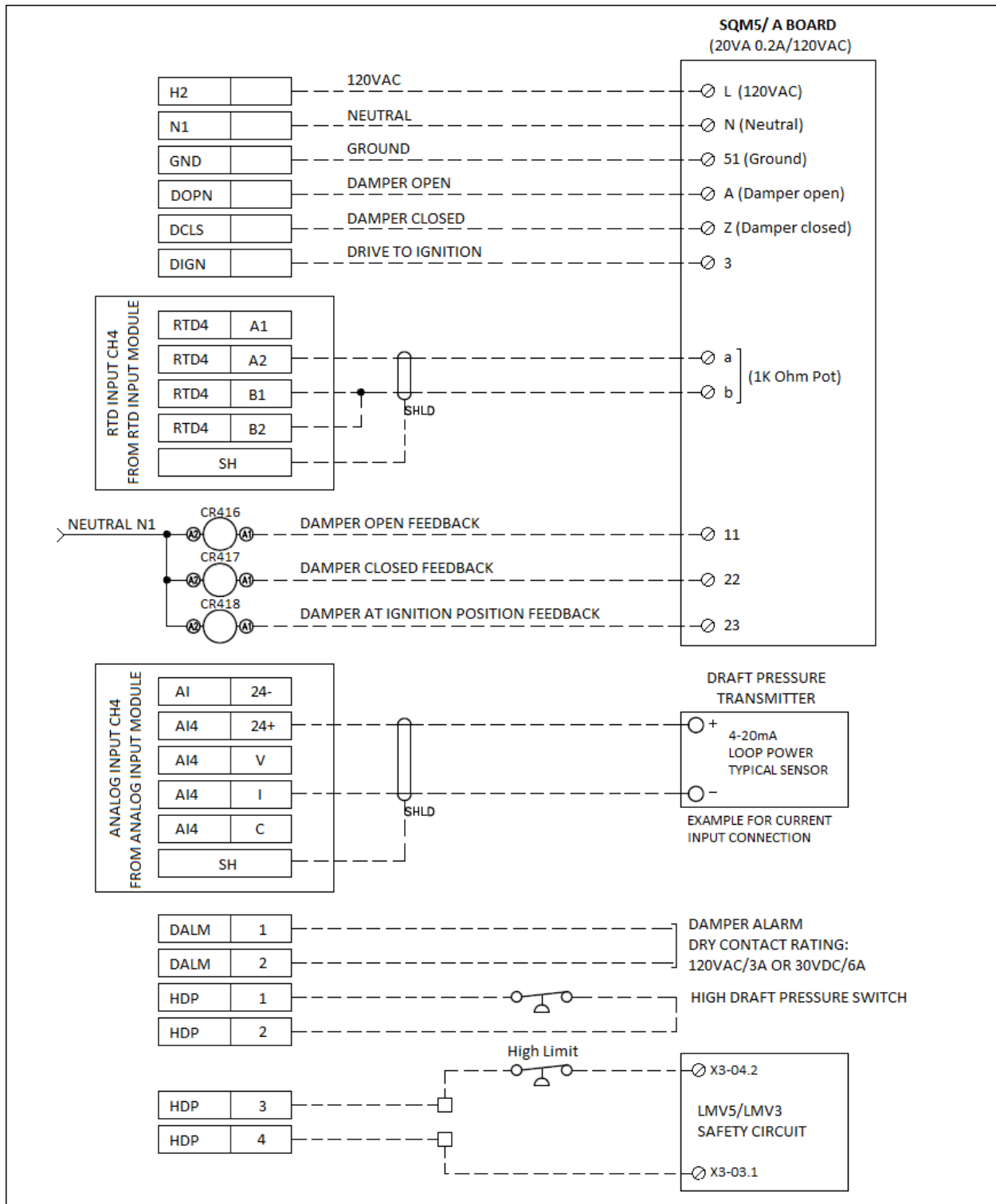

## Field Connections (continued)

### BMS Communications Connections

Standard Modbus TCP/IP:

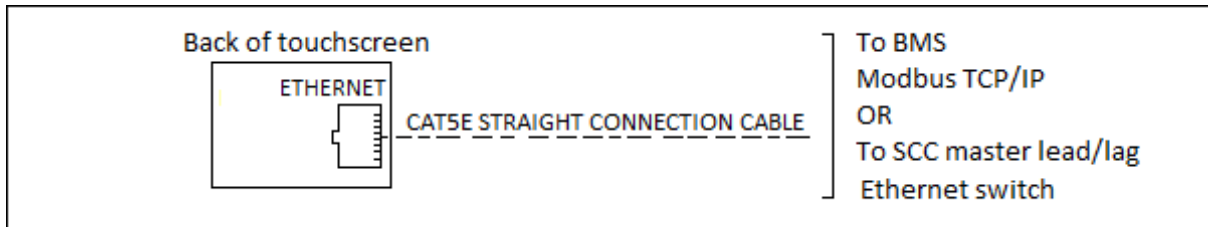

Standard Modbus TCP/IP with PLC annunciation:

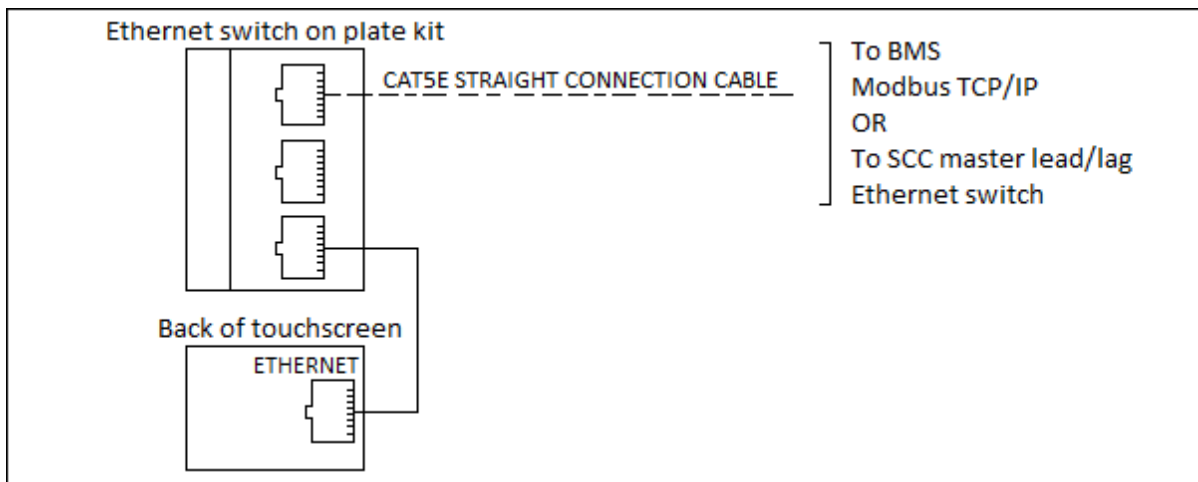

## Field Connections (continued)

### BMS Communications Connections

BACnet/IP:

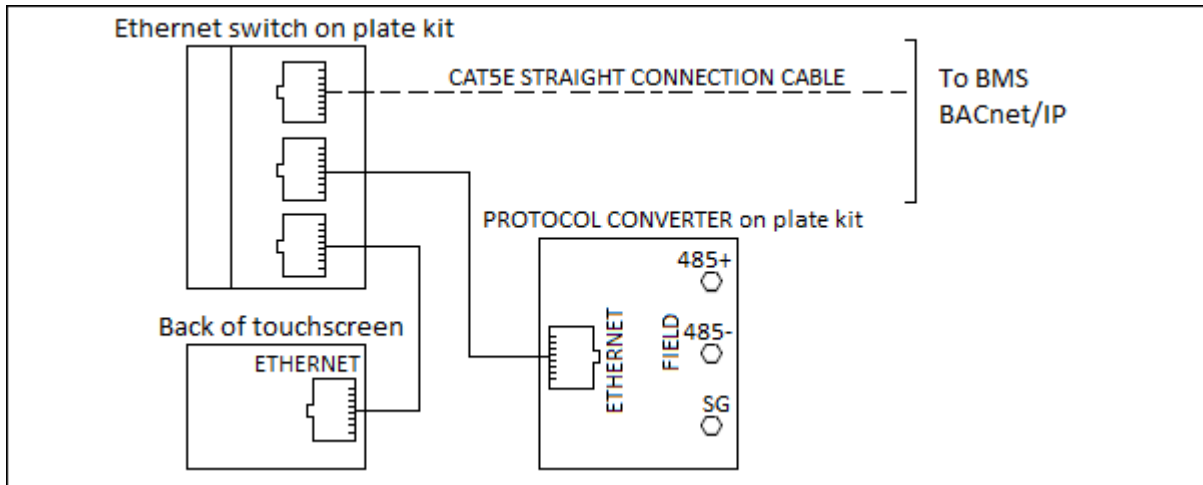

LonWorks:

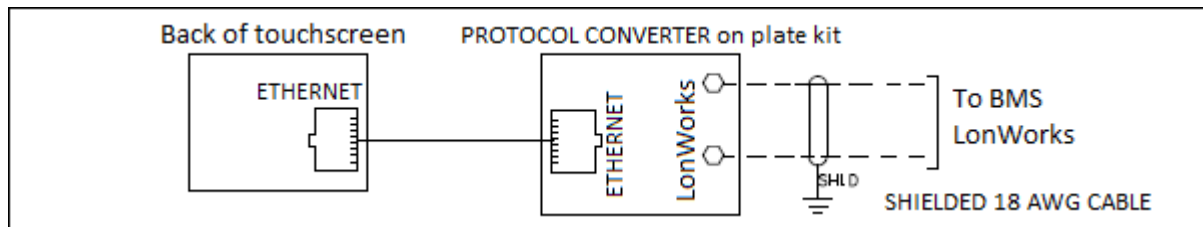

## Field Connections (continued)

N2 Johnson Metasys, BACnet MS/TP, or Modbus RTU:

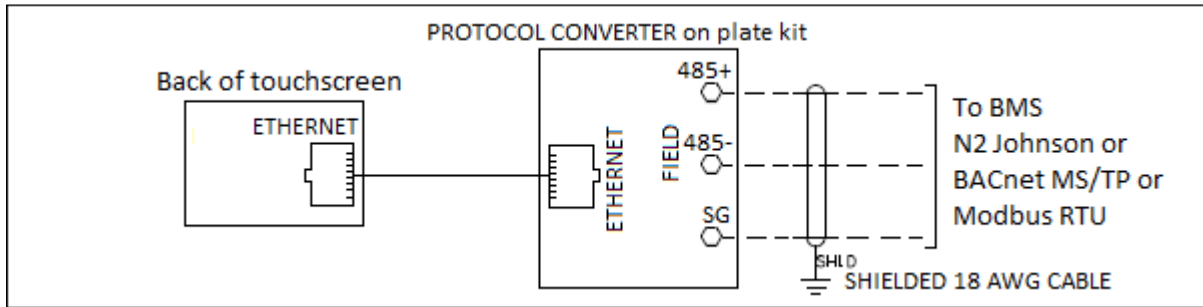

BMS Serial Connection, Modbus RTU RS485 connection without touchscreen:

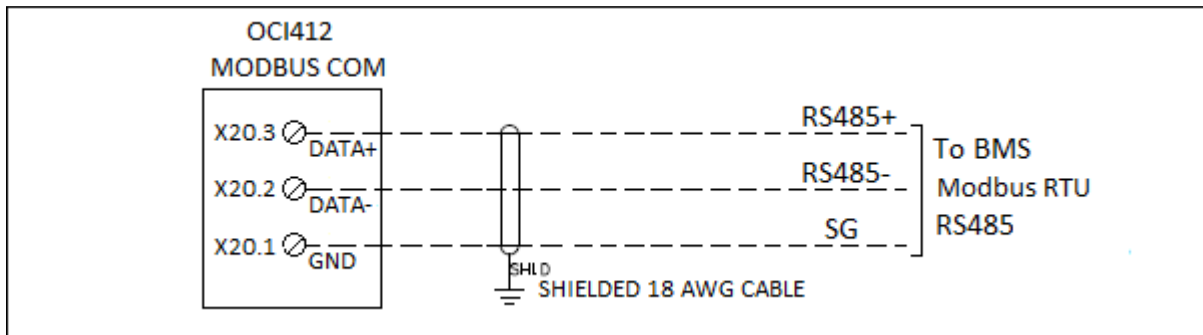

## Internal Panel Parts Descriptions

### 24" x 24" x 10" Combustion Enclosure

TS-CE22X-x-XXB-Xx2-XXXX

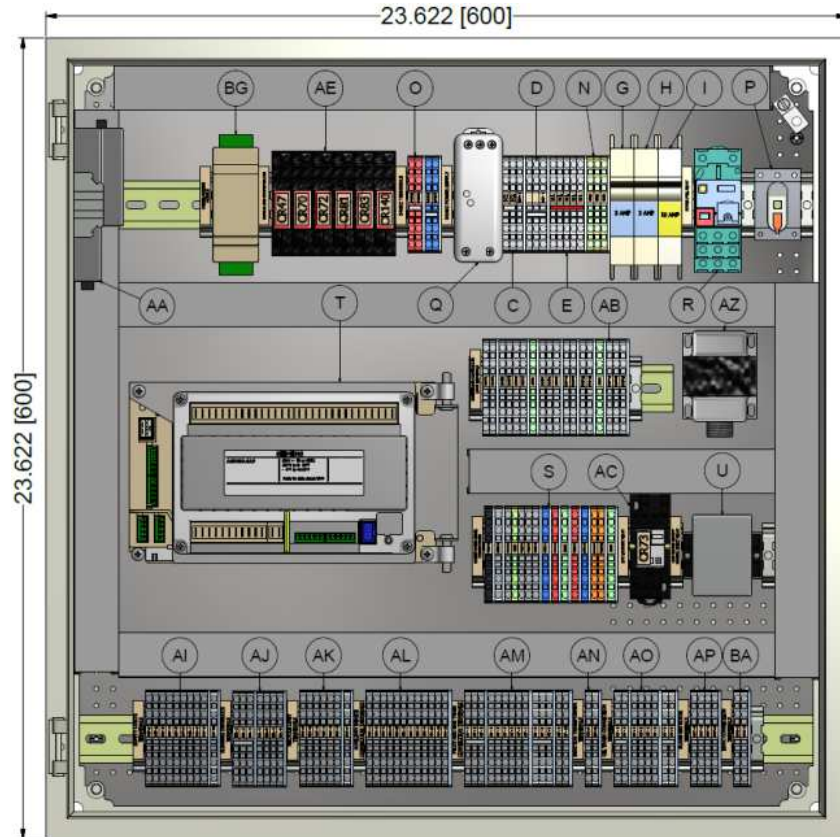

C- 120 VAC H1 power distribution terminals  
D- 120 VAC H2 power distribution terminals  
E- Neutral N1 distribution terminals  
G- RWF55 water level circuit protection  
H- DC power supply circuit protection  
I- Main power circuit protection  
N- Ground GND distribution terminals  
O- 24 VDC +/- distribution terminals  
P- Main disconnect single phase 120VAC 16A/40A  
Q- 60W 24 VDC power supply  
R- Power fail relay  
S- RWF55 water level terminals  
T- LMV linkage control and flame safe guard controller  
AA- BMS interface module (BACnet, LON, N2) (optional)

AB- RWF55 load controller LMV51 only (optional)  
AC- LMV lockout relay  
AE- LMV5 output relays  
AI- Safety limits field terminals  
AJ- Running interlocks field terminals  
AK- Recycle limits field terminals  
AL- Auxiliary devices output terminals  
AM- Pilot and gas train field terminals  
AN- Ignition transformer field terminals  
AO- Oil train field terminals (optional)  
AP- Flame scanner field terminals  
AZ- Water level SKD actuator 24 VAC transformer (optional)  
BA- HVAC LMV start command output terminals  
BG- OCI412 Modbus module

## Internal Panel Parts Descriptions (continued)

### 32" x 32" x 10" Combustion Enclosure

TS-CE22X-x-E8B-x22-XXXX

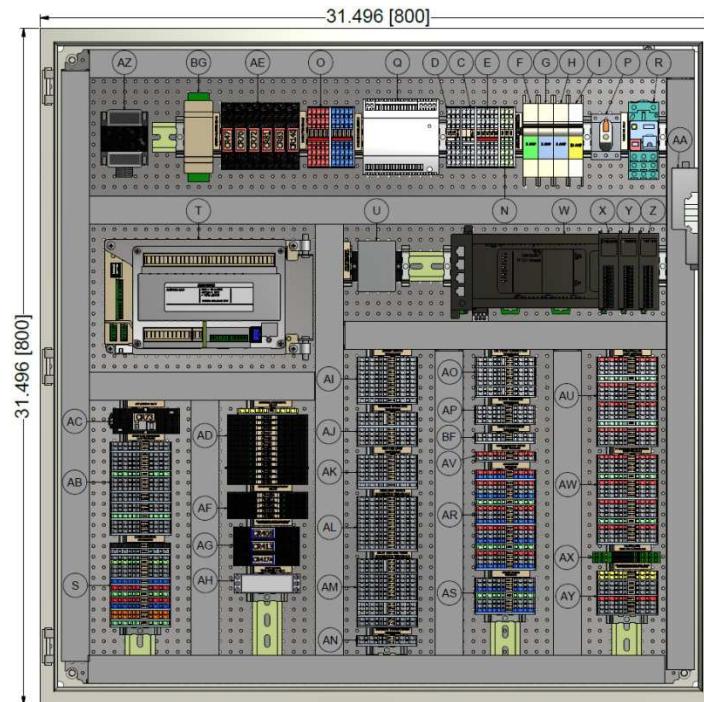

- C- 120 VAC H1 power distribution terminals
- D- 120 VAC H2 power distribution terminals
- E- Neutral N1 distribution terminals
- F- Draft control circuit protection
- G- RWF55 water level circuit protection
- H- DC power supply circuit protection
- I- Main power circuit protection
- N- Ground GND distribution terminals
- O- 24 VDC +/- distribution terminals
- P- Main disconnect single phase 120 VAC 16A/40A
- Q- Up to 90W 24 VDC power supply
- R- Power fail relay
- S- RWF55 water level terminals
- T- LMV linkage control and flame safe guard controller
- U- Manual reset LWCO Warrick relay (optional)
- W- Programmable Logic Controller (PLC) (optional)
- X- 4 input analog input module (optional)
- Y- 4 input RTD input module (optional)
- Z- 4 input RTD input module (optional)
- AA- BMS interface module (BACnet, LON, N2) (optional)
- AB- RWF55 load controller LMV51 only
- AC- LMV lockout relay
- AD- Expanded annunciation 13 relays 120 VAC
- AE- LMV3 output relays

- AF- Circulating pump hot water boilers only, general alarm, PLC health, and monitored digital value output relays
- AG- Draft control relays (optional)
- AH- Draft control high pressure trip time delay timer (optional)
- AI- Safety limits field terminals
- AJ- Running interlocks field terminals
- AK- Recycle limits field terminals
- AL- Auxiliary devices output terminals
- AM- Pilot and gas train field terminals
- AN- Ignition transformer field terminals
- AO- Oil train field terminals (optional)
- AP- Flame scanner field terminals
- AR- 4 analog input field terminals (optional)
- AS- 2 analog output field terminals (optional)
- AU- 4 RTD inputs field terminals (optional)
- AV- Circulating pump proven field terminals
- AW- 4 RTD for economizer inputs field terminals (optional)
- AX- Draft damper open/close output relays and draft damper alarm dry contact (optional)
- AY- Draft control to LMV permissive and shutdowns terminals (optional)
- AZ- Water level SKD actuator 24 VAC transformer (optional)
- BF- HVAC LMV start command output terminals
- BG- OCI412 Modbus module

## Internal Panel Parts Descriptions (continued)

### 42" x 32" x 10" Combustion Enclosure

TS-CE22X-x-E8B-x22-TDG

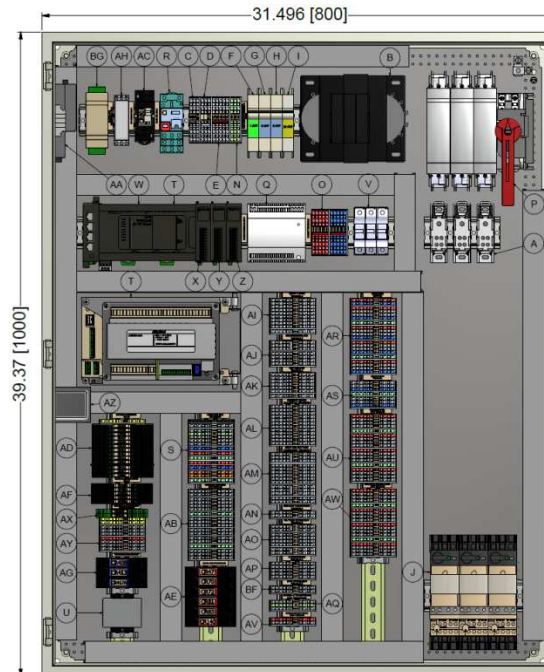

A-	Power distribution 3 phase blocks	AC-	LMV Lockout Relay
B-	750/1000 VA control transformer (120-480 VAC)	AD-	Expanded annunciation 13 relays 120 VAC
C-	120 VAC H1 power distribution terminals	AE-	LMV5 output relays
D-	120 VAC H2 power distribution terminals	AF-	Circulating pump hot water boilers only, general alarm, PLC health, and monitored digital value output relays
E-	Neutral N1 distribution terminals	AG-	Draft control relays (optional)
F-	Draft control circuit protection	AH-	Draft control high pressure trip time delay timer (optional)
G-	RWF55 water level circuit protection	AI-	Safety limits field terminals
H-	DC power supply circuit protection	AJ-	Running interlocks field terminals
I-	Main power circuit protection	AK-	Recycle limits field terminals
J-	Blower motor, oil pump, and compressor motor starters (optional)	AL-	Auxiliary devices output terminals
N-	Ground GND distribution terminals	AM-	Pilot and gas train field terminals
O-	24 VDC +/- distribution terminals	AN-	Ignition transformer field terminals
P-	Main three phase 480 VAC fused disconnect 30A or 60A	AO-	Oil train field terminals (optional)
Q-	Up to 90W 24 VDC power supply	AP-	Flame scanner field terminals
R-	Power fail relay	AR-	4 Analog input field terminals (optional)
S-	RWF55 water level terminals	AS-	2 Analog output field terminals (optional)
T-	LMV linkage control and flame safe guard controller	AU-	4 RTD input field terminals (optional)
U-	Manual reset LWCO Warrick relay (optional)	AV-	Circulating pump proven field terminals
V-	Control Transformer primary and secondary fuse holders	AW-	4 RTD for economizer inputs field terminals (optional)
W-	Programmable Logic Controller (PLC) (optional)	AX-	Draft damper open/close output relays and draft damper alarm dry contact (optional)
X-	4 input analog input module (optional)	AY-	Draft control to LMV permissive and shutdowns terminals (optional)
Y-	4 input RTD input module (optional)	AZ-	Water level SKD actuator 24 VAC transformer (optional)
Z-	4 input RTD input module (optional)	BF-	HVAC LMV start command output terminals
AA-	BMS interface module (BACnet, LON, N2) (optional)	BG-	OCI412 Modbus module
AB-	RWF55 load controller LMV51 only		

## Enclosure Dimensions

Dimensions in inches; millimeters in brackets

### 24" x 24" x 10" Combustion Enclosure

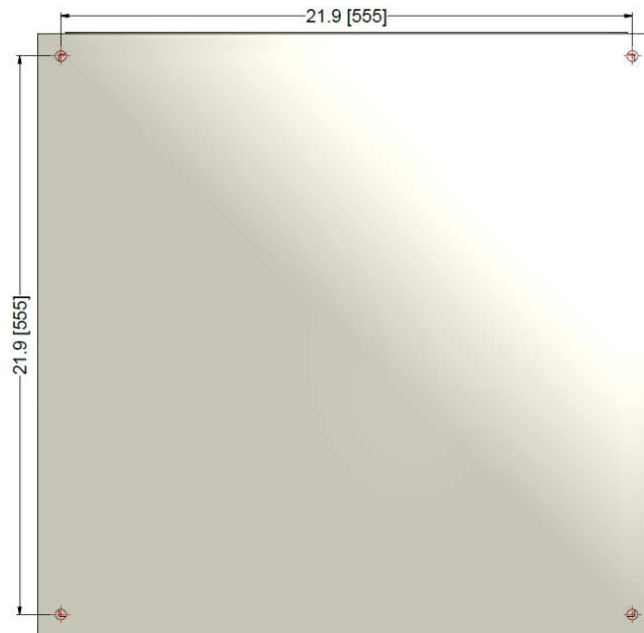
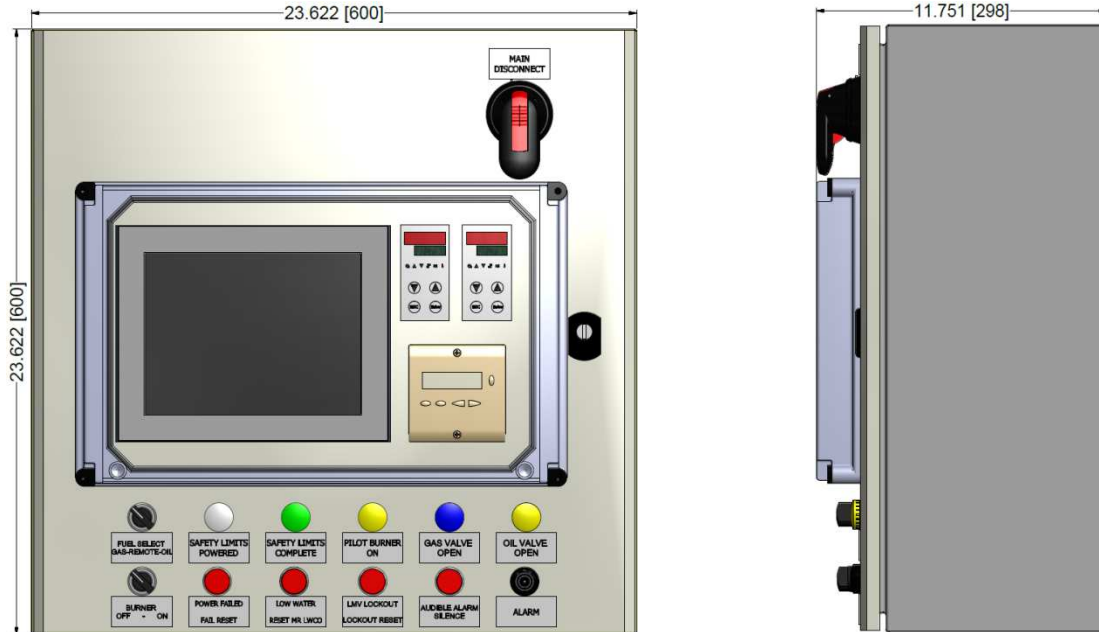

## Enclosure Dimensions (continued)

Dimensions in inches; millimeters in brackets

### 32" x 32" x 10" Combustion Enclosure

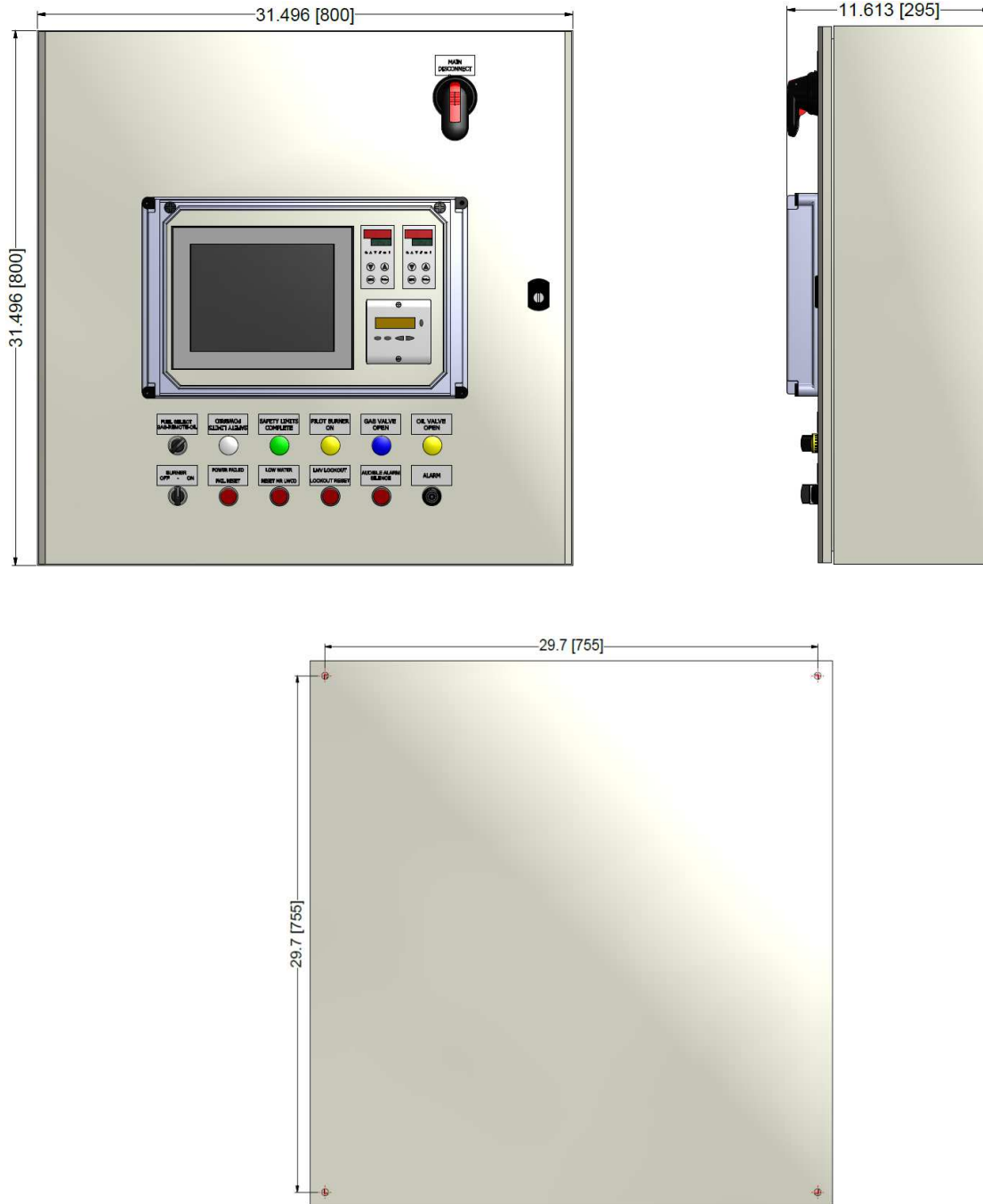

## Enclosure Dimensions (continued)

Dimensions in inches; millimeters in brackets

### 40" x 32" x 10" Combustion Enclosure

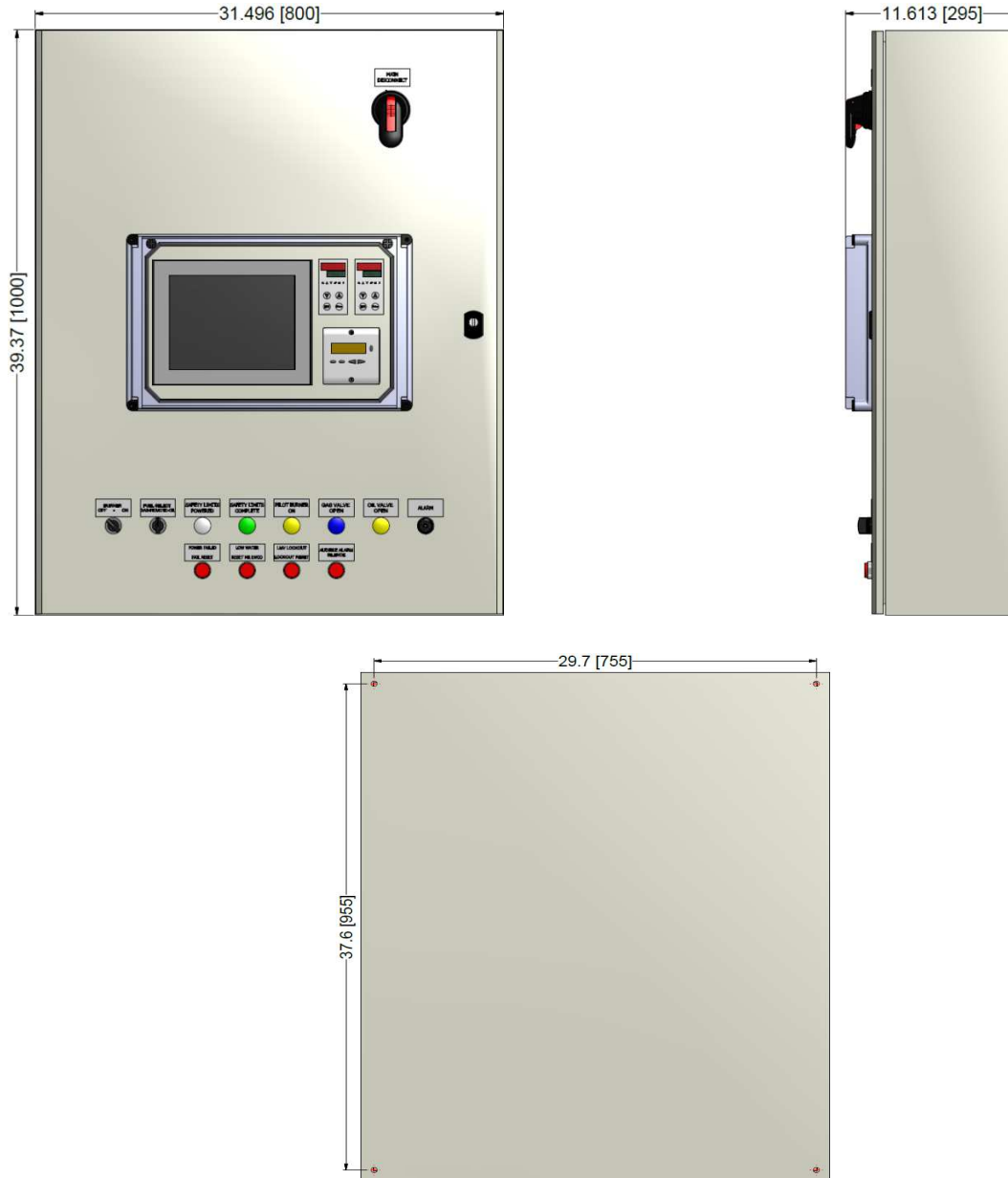

Information in this publication is based on current specifications. The company reserves the right to make changes in specifications and models as design improvements are introduced. Product or company names mentioned herein may be the trademarks of their respective owners. © 2009 SCC Inc.