

TS Series

TS-CE... Combustion Enclosures with LMV5...

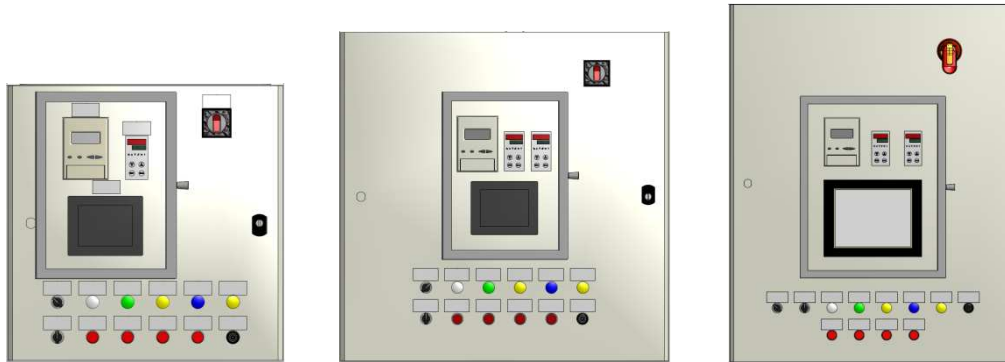

Description

TS-CE... series combustion enclosure with Siemens LMV5 linkageless controller sets the new standard for combustion control and monitoring technologies. The preprogrammed touchscreen and optional PLC annunciation packages provide monitoring and control for any boiler and burner installation with excellent control capability, configuration flexibility, and simple connectivity to a SCC Master Lead/Lag panel; the TS-CE... combustion enclosure provides easy installation.

The TS-CE... combustion control panels with LMVs provide a common centralized center to monitor and retrieve the information for efficient operation of the burner.

All burner flame safe guard and combustion safety control is performed by the advanced Siemens linkageless controller.

Touch screen option includes Modbus TCP/IP communication to a separate master lead lag panel, or to a third party BMS as standard with touchscreens. Optional capability to communicate with building management systems via Modbus RTU, RS232 or RS485 connections, Johnson Metasys N2, BACnet MSTP or BACnet IP, LON, ProfiNet and Profibus.

Features

TS-CE... combustion enclosures with LMV52 is UL 508 listed and include the following:

- 6" or 10", touchscreen option
- LMV51 or LMV52 Siemens linkageless control and flame safeguard
- Backlit AZL52 display
- Control up to 6 SQM45/48/91 actuators (up to 5 simultaneously)
- Programmable logic controller (PLC)
- Steam or hot water boiler control
- Flame supervision and flame strength monitoring
- UV or IR scanners
- Single or dual fuel
- Oil pump control
- Blower motor control
- Atomizing compressor control
- Lead/lag ready with SCC TS... master lead/lag panel
- VSD control
- Blower motor sensor for motor RPM monitoring
- O₂ trim and monitoring (with LMV52 only)
- Efficiency calculation with O₂ (with LMV52 only)
- Thermal shock protection (PT1000 RTD required for steam boilers)
- Low fire hold based on temperature setpoint
- Temperature-based stepping start
- Time-based stepping start
- Combination of temperature and time-based stepping start
- FGR low temperature hold
- Shell water temperature monitoring
- External and proven interlocks
- Actuator position display
- LMV5 lockout and fault history
- Stack temperature monitoring
- Burner operating phase display
- Local touchscreen interface with Siemens LMV.../RWF controllers
- Touchscreens available in 6" or 10" sizes
- Boiler graphics and field tag information are field-configurable
- LMV... static, fuel, lockout and error history displayed
- Fuel-Air Ratio control curve displayed on touchscreen

-
- Local touchscreen interface with Siemens LMV.../RWF controllers
 - Boiler graphics and field tag information are field-configured
 - LMV... static, fuel and internal lockout and error history displayed
 - Alarm history stored for most recent 250 faults/alarms
 - Detailed annunciation of LMV... digital inputs and outputs
 - Variable Speed Drive information and setup when preprogrammed VFD (Yaskawa) is provided by SCC, Inc.
 - Remote setpoint, firing rate and/or enable of the LMV... or RWF... via BMS
 - Water level control option and status via RWF55
 - Metric or Standard units displayed
 - English or Spanish languages
 - Clear English or Spanish text for alarms
 - Circulating pump/isolation valve control outputs for hydronic boilers (option with expanded annunciator)
 - Expanded annunciator options include:
 - Four (4) analog inputs with field configurable label, span and type (0-10V, 2-10V, 0-20mA or 4-20mA), each with low and high alarm setpoints with auto or manual reset. Totalization available per minute or per hour. (option with expanded annunciator)
 - Four (4) Pt1000 (or Pt100) RTD temperature inputs with field configurable label. Each with low and high alarm setpoints with auto or manual reset. (option with expanded annunciator)
 - Two (2) analog outputs with field configurable span and type (0-10V, 2-10V, 0- 20mA or 4-20mA), each with low and high alarm setpoints with auto or manual reset. Totalization available per minute or per hour. (option with expanded annunciator)
 - Two (2) digital outputs with field configurable logic, including on and off delays. Manual or automatic reset. (option with expanded annunciator)
 - First-out annunciation option including thirteen (13) 120 VAC inputs with field labeling capability
 - Eight (8) selectable data logging variables stored in CSV format on USB drive
 - Four (4) selectable variables for trending up to 7 days
 - Economizer temperature monitoring (additional 4 input RTD card)

-
- Draft control with SQM5 actuator
 - Connection of two additional RWF55 controllers
 - Screen saver with PV, setpoint, demand and status
 - Standard Modbus TCP/IP to BMS communications
 - Additional BMS communication options available
 - Email communications and text messaging up to six (6) recipients including alarms, faults and screen shots (screen shot viewer via USB)
 - Remote monitoring via mobile device (Smart Phone, tablet, etc.)
 - Compatible with SCC Master Panel Lead Lag system and others

Application

TS-CE... combustion enclosure panel with LMV5 systems are suited for hot water and steam boilers up to 600 in/lb of actuator torque, for single or dual fuel applications.

**Standard
Components**

- LMV5 linkageless parallel positioning flame safeguard
- LMV5 CANbus power supply transformer
- Power fail relay
- System alarm
- Circuit breaker, 3 Amp, single pole
- Circuit breaker, 10 Amp, single pole
- Non-fused disconnect switch
- Burner ON/OFF switch
- Safety limits powered, white indication light
- Safety limits complete, green indicator light
- Pilot burner ON, yellow indicator light
- Gas valve open, blue indicator light
- Oil valve open, yellow indicator light
- Red illuminated push button
- Three position fuel selector switch
- Power fail, red illuminated indicator light with reset push button
- Low water, red illuminated indicator light with reset push button
- LMV lockout, red illuminated indicator light with reset push button
- Alarm reset push button
- Alarm horn
- Gray terminals, general
- White terminals, 120 VAC neutral
- Black terminals, 120 VAC hot
- Red terminals, 24 VDC +
- Blue terminals, 24 VDC -
- Orange terminals, 24 VAC
- Yellow terminals, Dry contact powered from second source
- Green non-grounding, shield terminals
- Green/yellow PE terminals

Optional Components

- 6" or 10", Touchscreens
- Programmable Logic Controller with additional annunciation inputs
- Second CANBUS Power Transformer Fuse Protection with fuses and fuse holder
- LWCO manual and auto Reset Warrick relays for probe type level control
- Draft control with Siemens SQM5 actuator only
- NEMA 12/ NEMA 4
- Additional external load or water level controllers
- BMS communications Options
- Main 3 Phase Fused Disconnect 30Amps/ 60A Amps/30HP Max
- VSD 3 Phase Fused Disconnect
- 1000 VA Circuit Control Transformer
- Blower motor starter
- Oil and compressor motor starters with overload and built in disconnects
- VSD control
- Fan Air Cooling
- Deaerator/Surge control panels. See TS-3000
- Master lead lag control panel. See TS-2000

Specifications Without 3-Phase Power

		With Touchscreen	W/out Touchscreen
Electrical characteristics	Main power	120 VAC	120 VAC
	Component power	24 VDC/VAC	120 VAC
	Power consumption	≤ 960 VA	≤ 740 VA
Operating environment	Operating temperature	32 to 122 °F [0 to 50 °C]	-4 to 140 °F [-20 to 60 °C]
	Humidity	Max. 85% with no condensation	Max. 85% with no condensation

Specifications With 3-Phase Power

		With Touchscreen	W/out Touchscreen
Electrical characteristics	Main power	480 VAC	480 VAC
	Current	≤ 30 Amps	≤ 30 Amps
	Component power	24 VDC/VAC	120 VAC
	Power consumption	≤ 960 VA	≤ 740 VA
Operating environment	Operating temperature	32 to 122 °F [0 to 50 °C]	-4 to 140 °F [-20 to 60 °C]
	Humidity	Max. 85% with no condensation	Max. 85% with no condensation

Field Connections

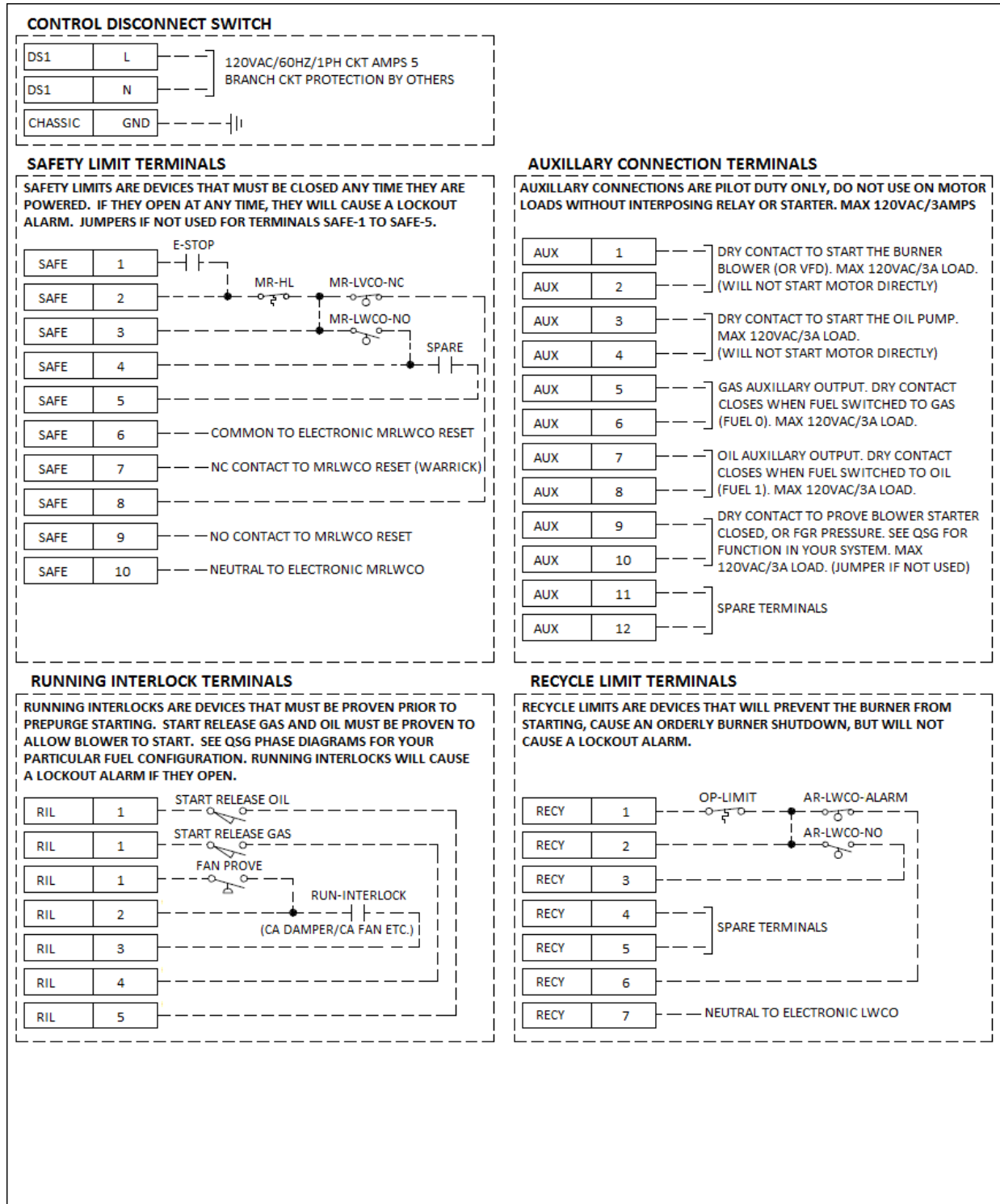

Field Connections (continued)

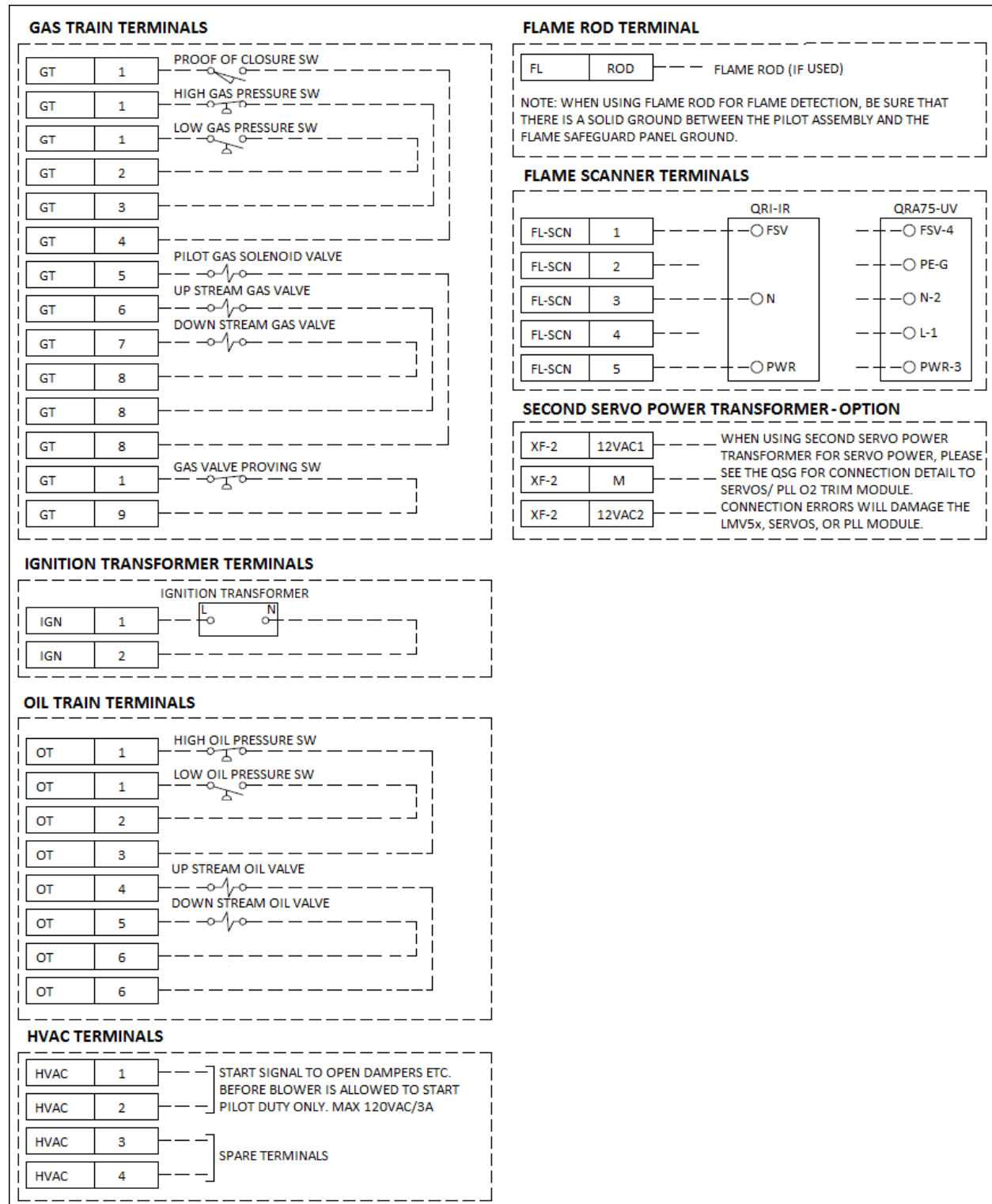

Field Connections (continued)

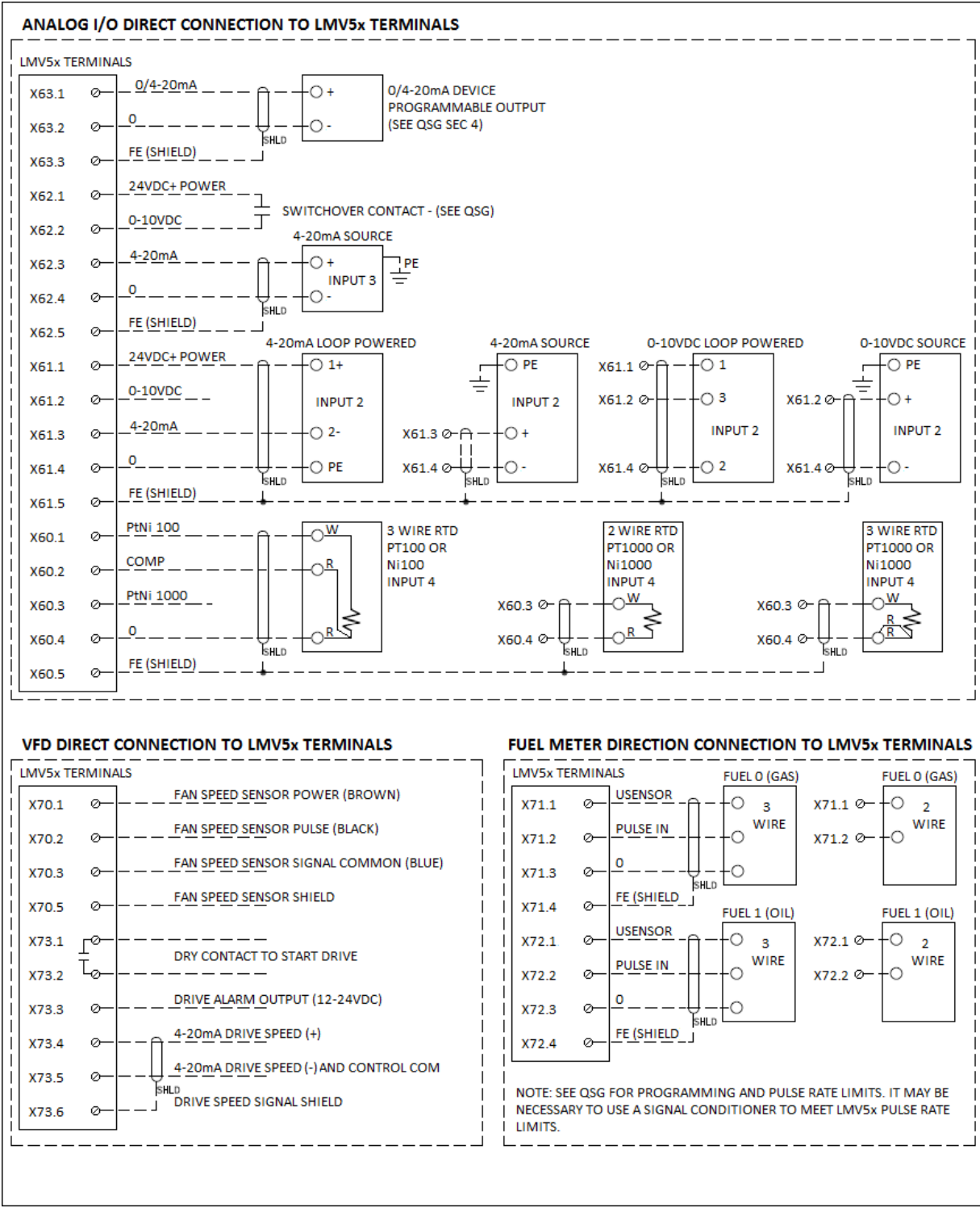

Field Connections (continued)

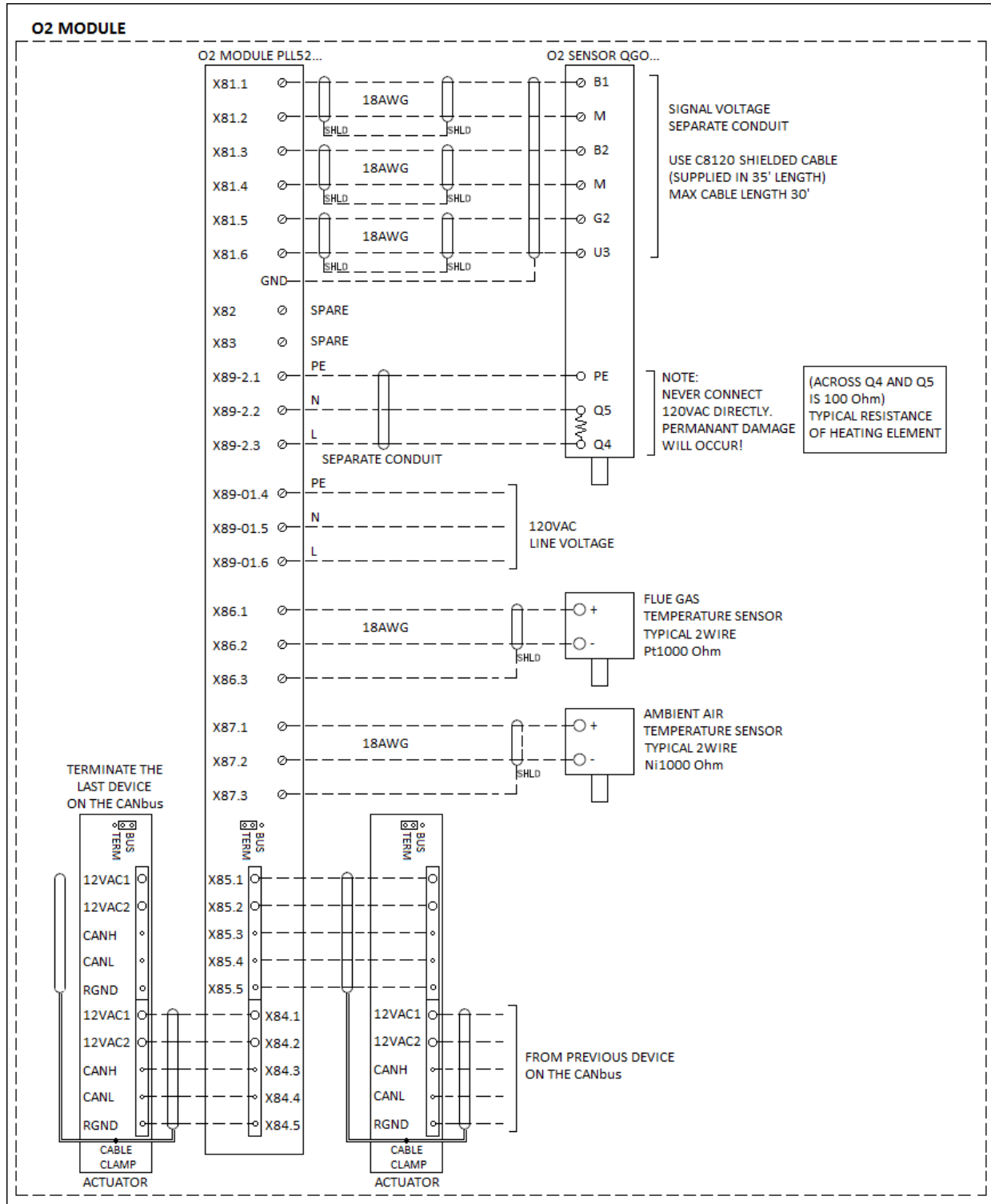

Field Connections (continued)

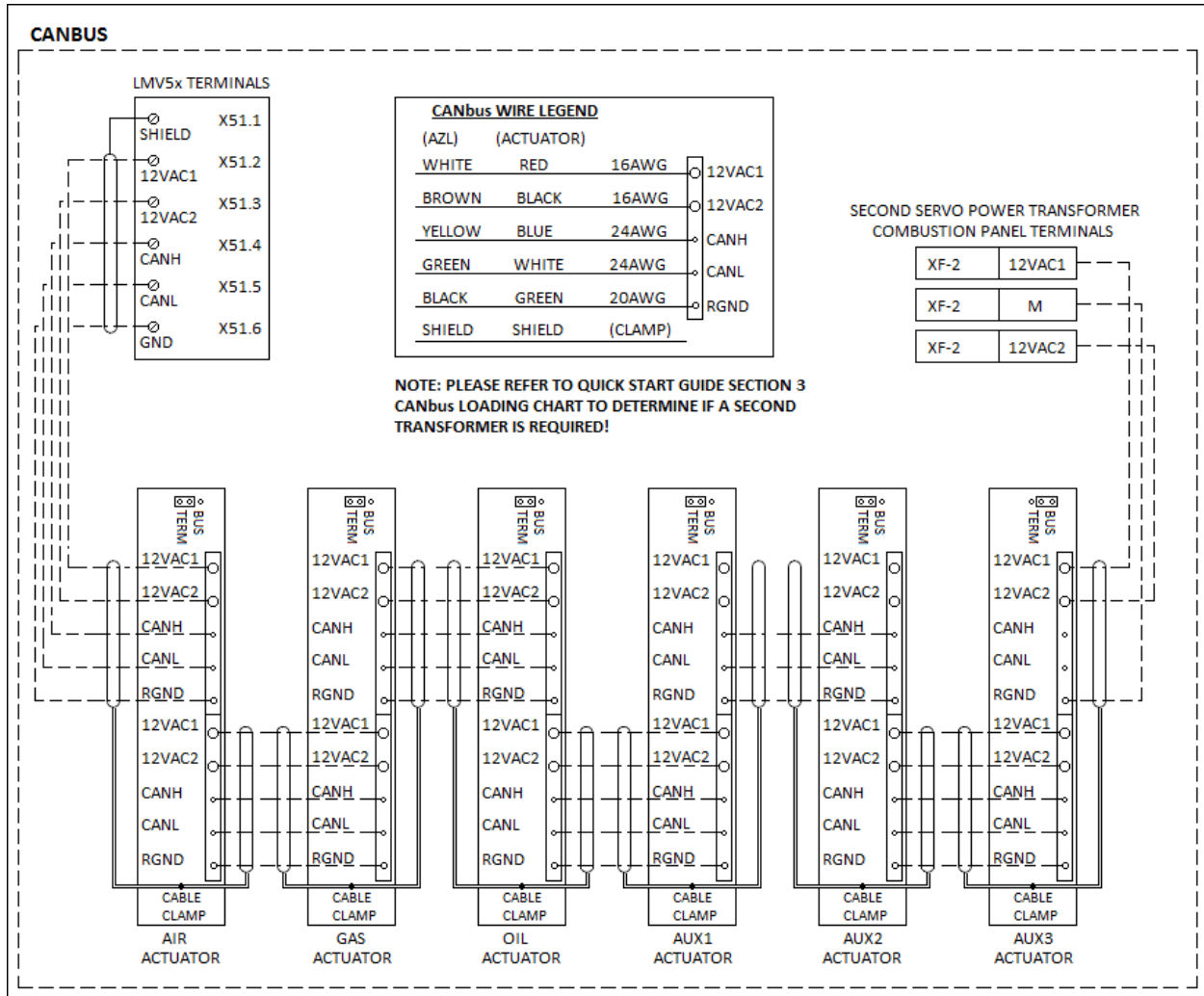

Note: Only 4 actuators may be connected on an LMV51 controller.

Field Connections (continued)

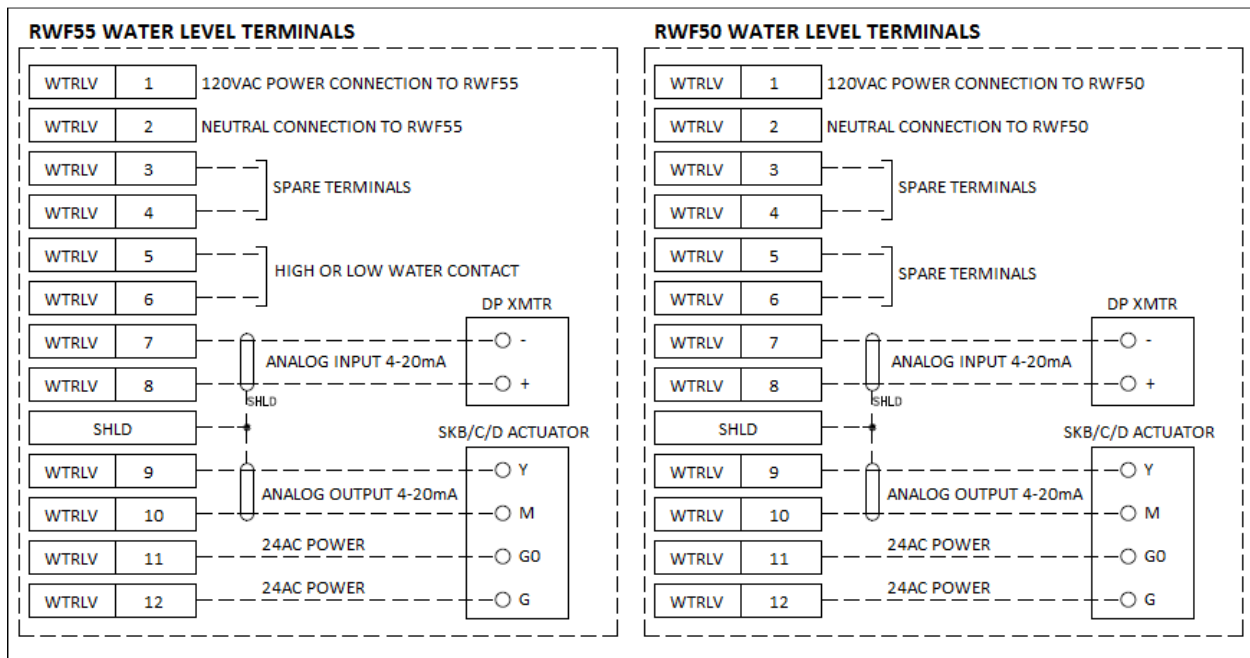
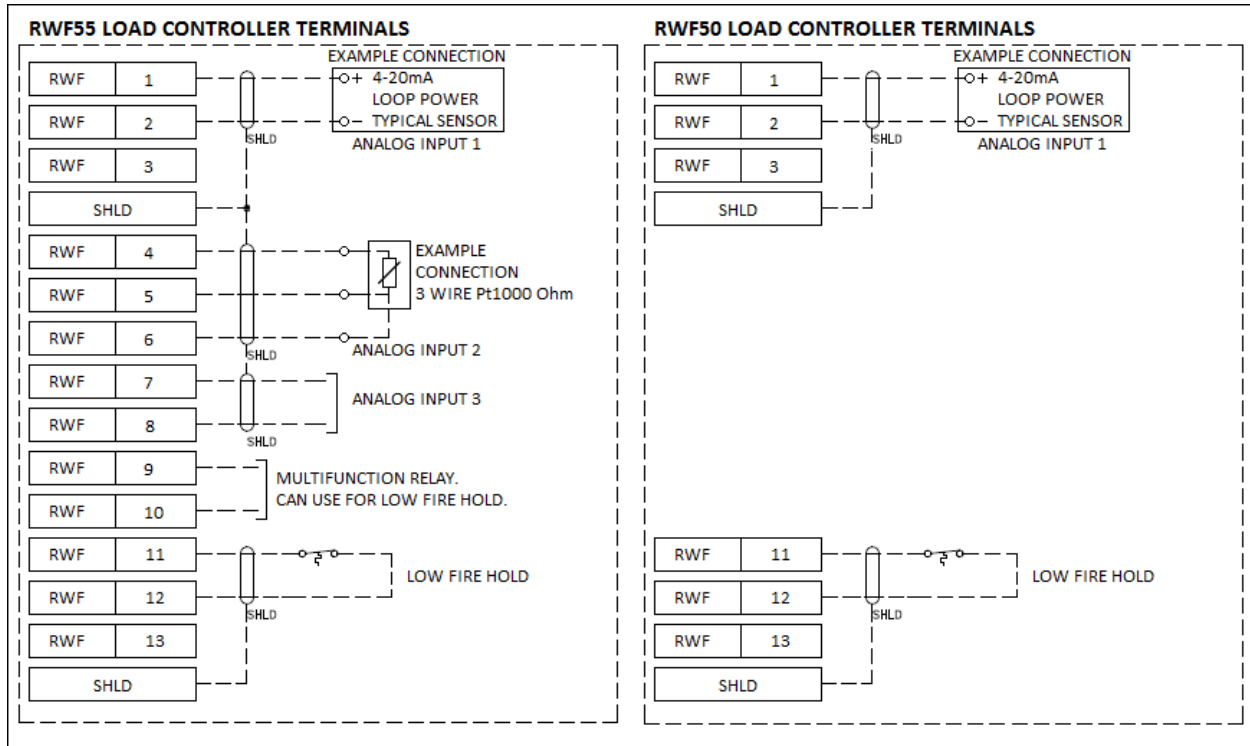

Field Connections (continued)

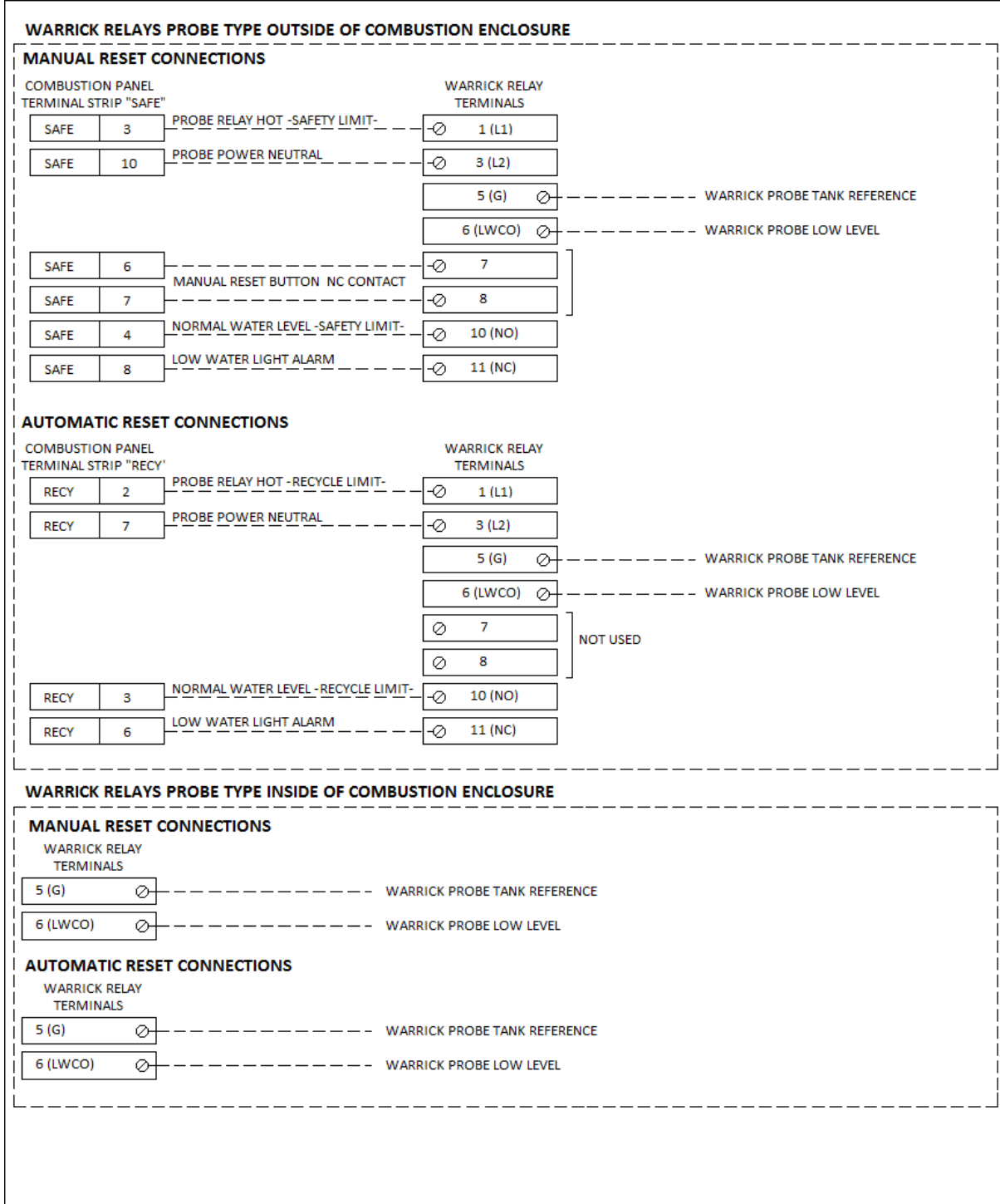

Field Connections (continued)

Additional RWF55 loop control Modbus connection only for Kits with annunciators options up to connections

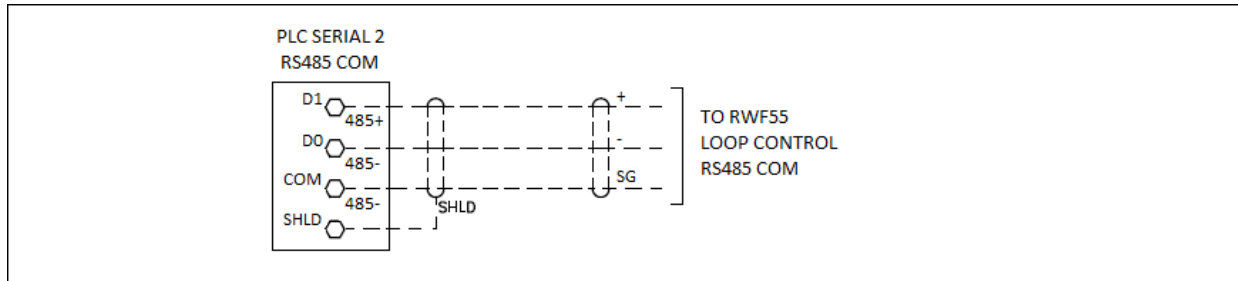

Standard annunciation 13 120VAC inputs

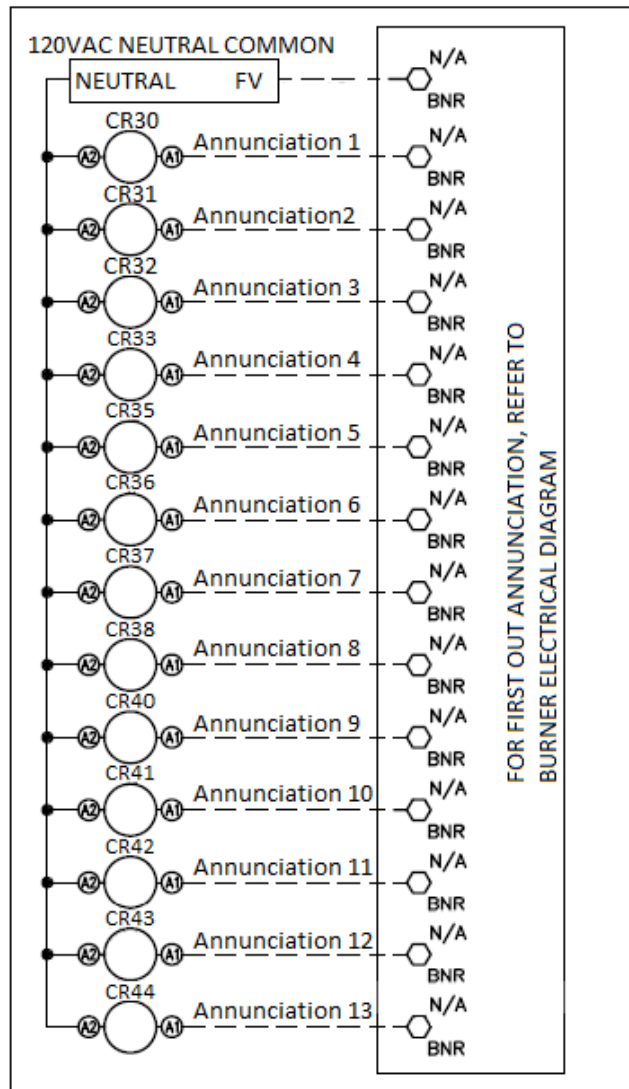

Connections (continued)

Output terminals

Pump proven input terminals

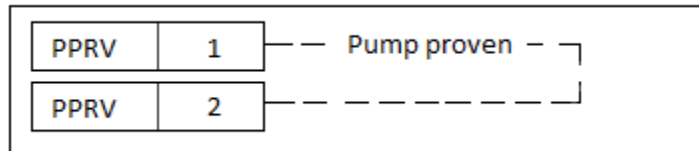

Outputs relay terminals

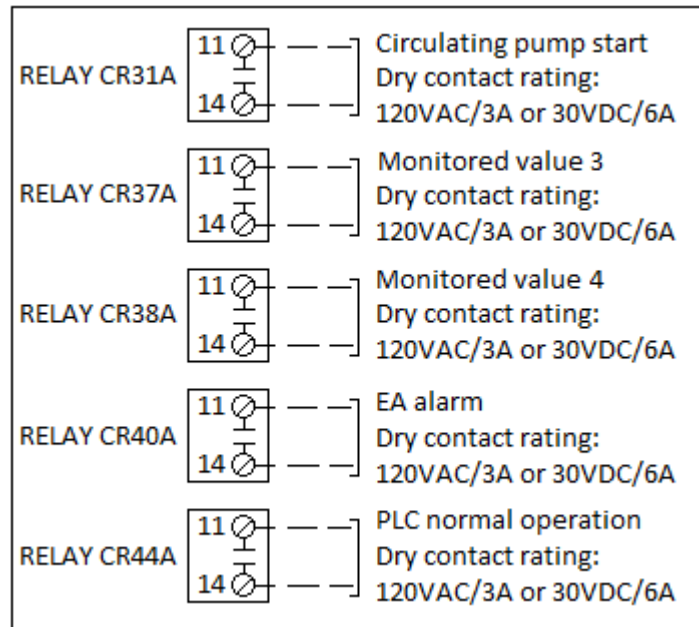

Connections (continued)

Analog input terminals (no draft control)

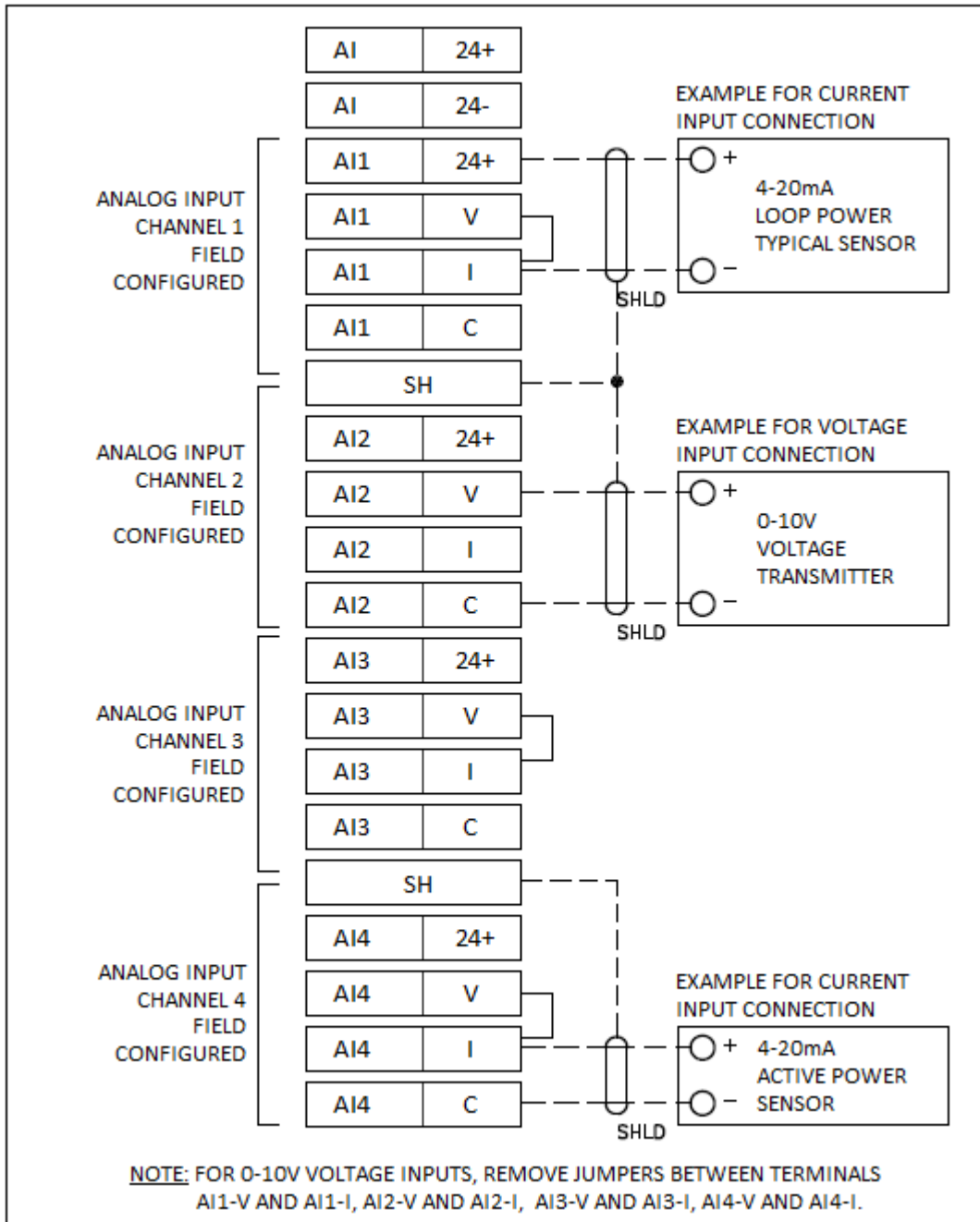

Connections (continued)

Analog output terminals

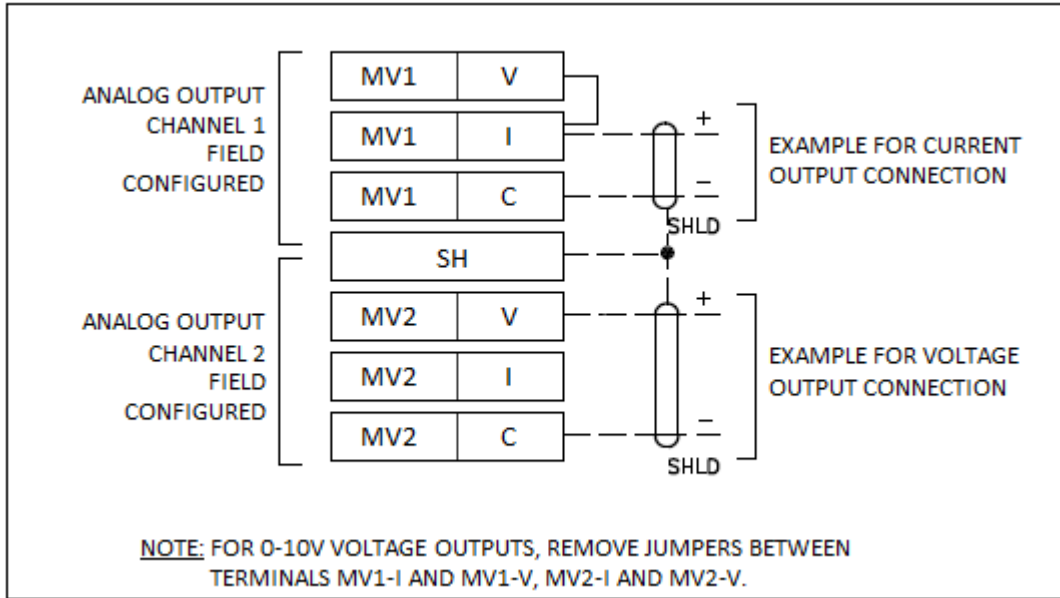

Connections (continued)

Analog input terminals (with draft control)

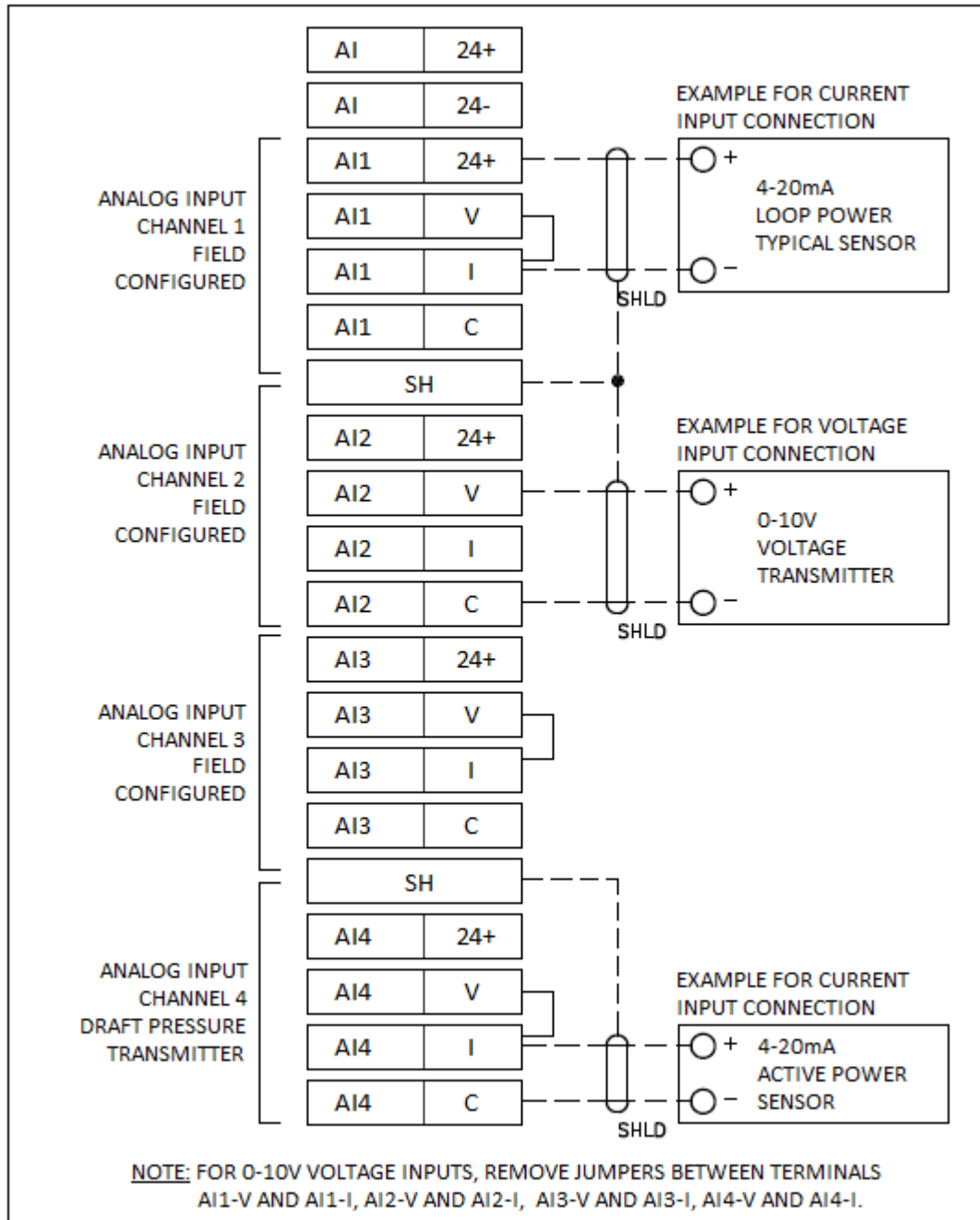

Connections (continued)

RTD 100/1000 Ohm input terminals (no draft control)

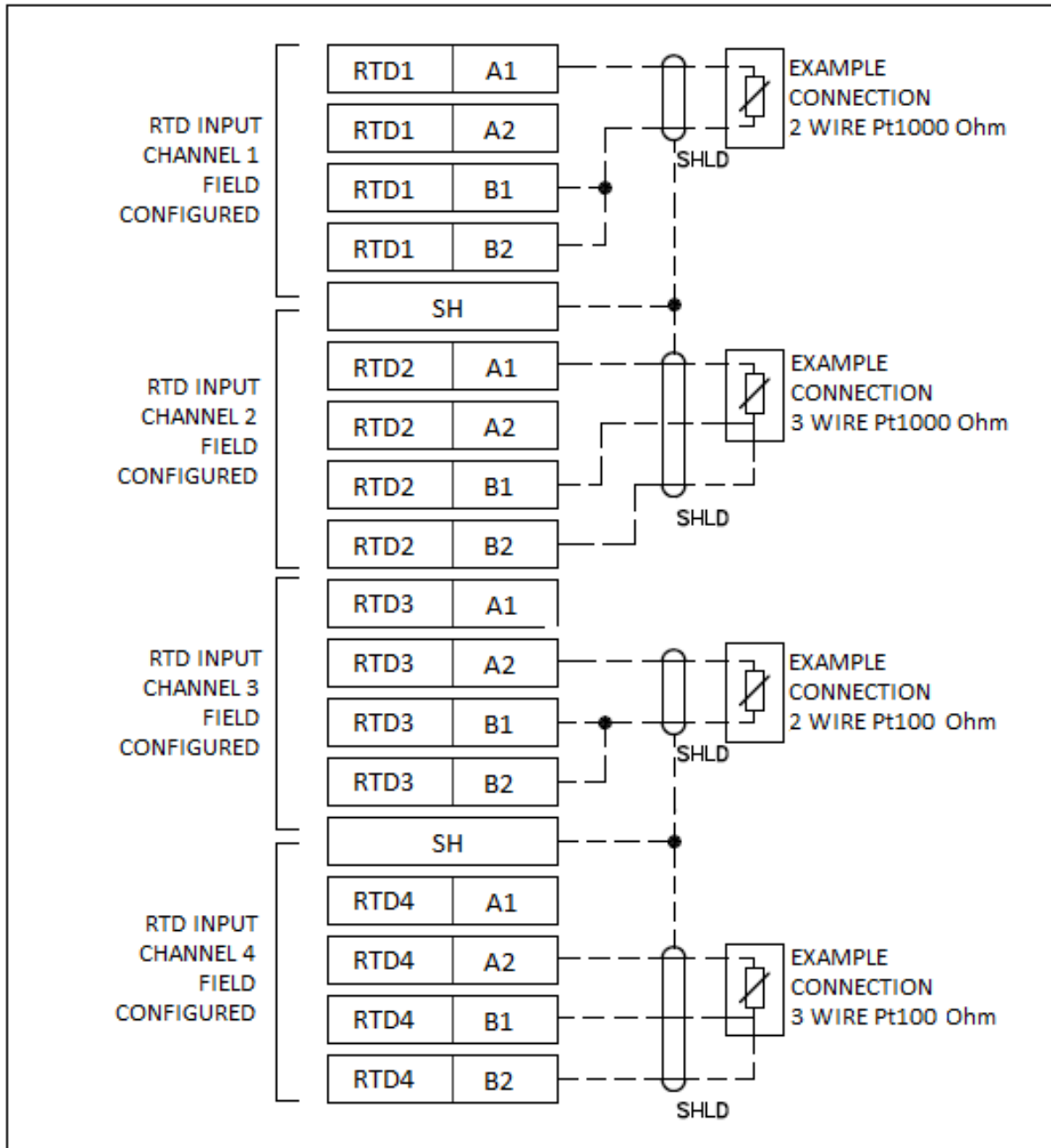

Connections (continued)

RTD 100/1000 Ohm input terminals (with draft control)

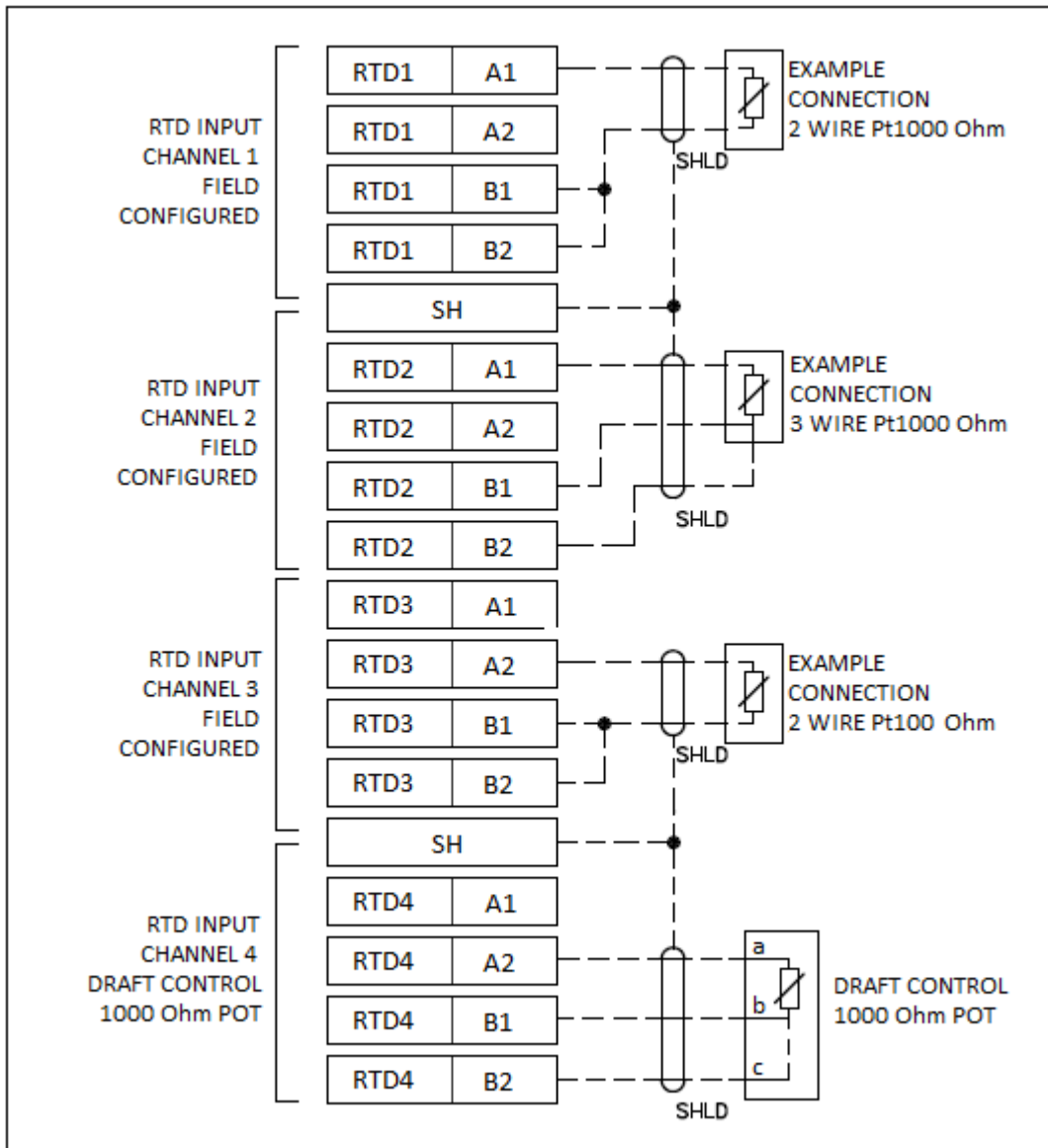

Connections (Continued)

RTD 100/1000 Ohm input terminals for economizer

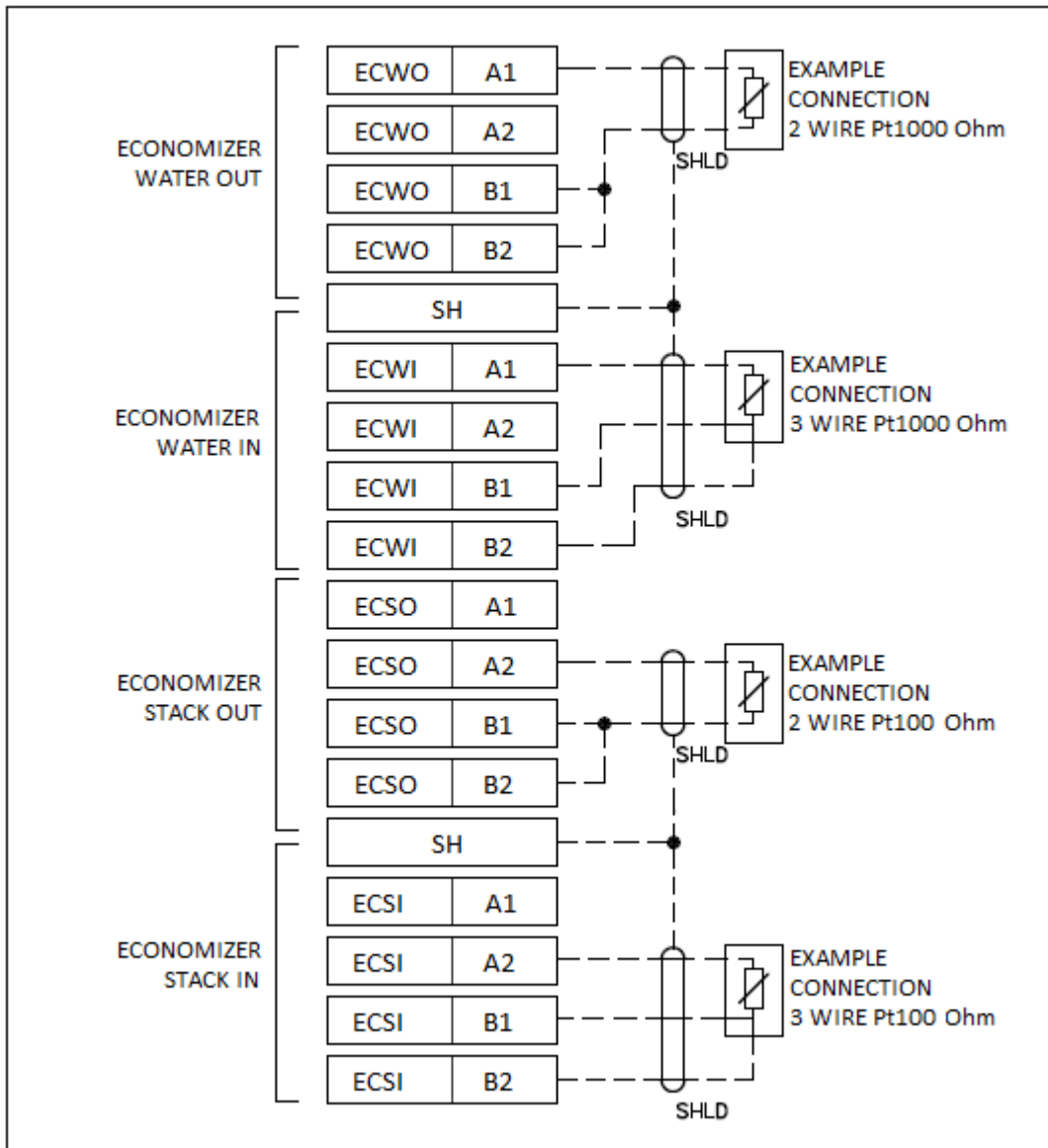

Connections (Continued)

Draft Control

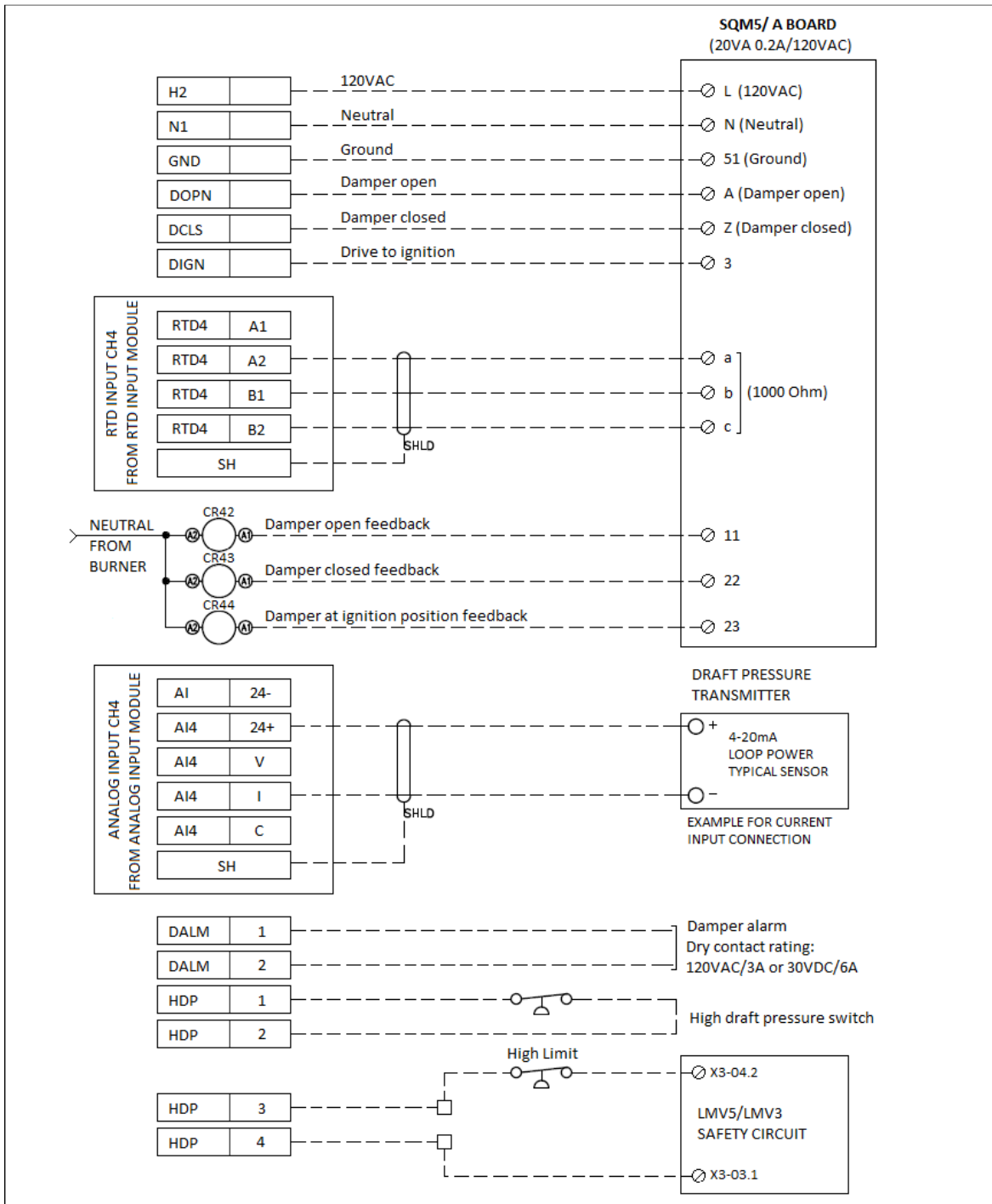

Connections (Continued)

BMS Communications Connections

Standard Modbus TCP/IP

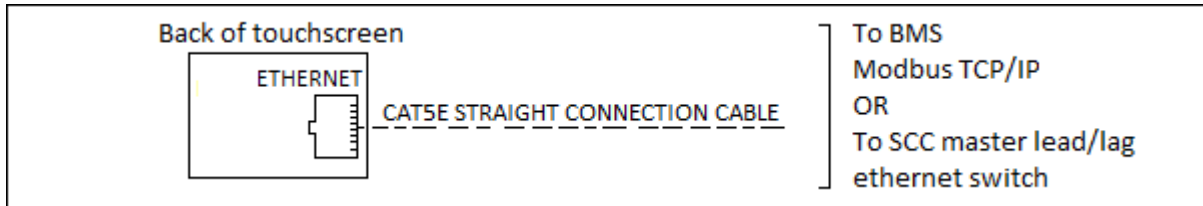

Standard Modbus TCP/IP with PLC annunciation

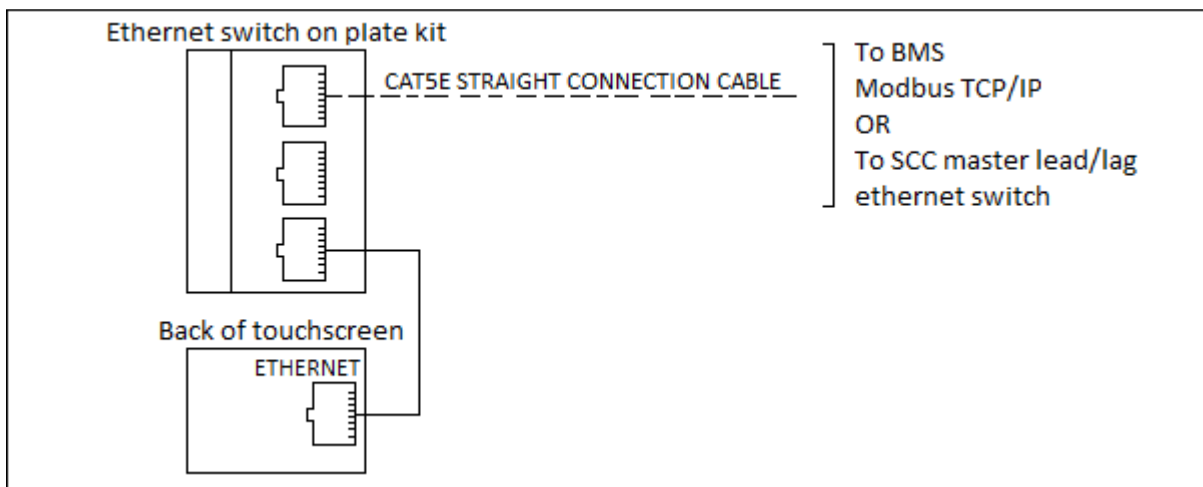

BACnet/IP

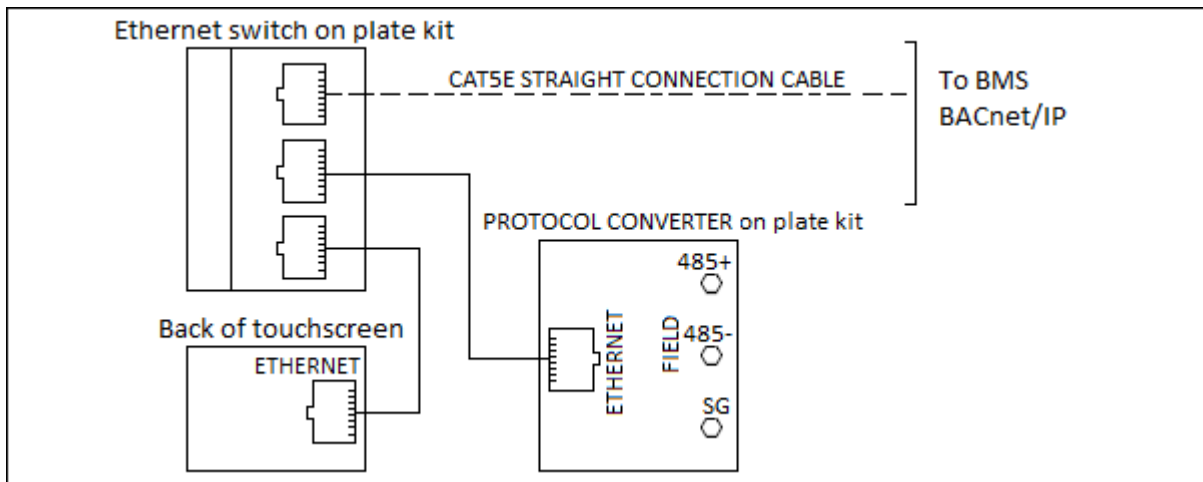

Connections (Continued)

LonWorks

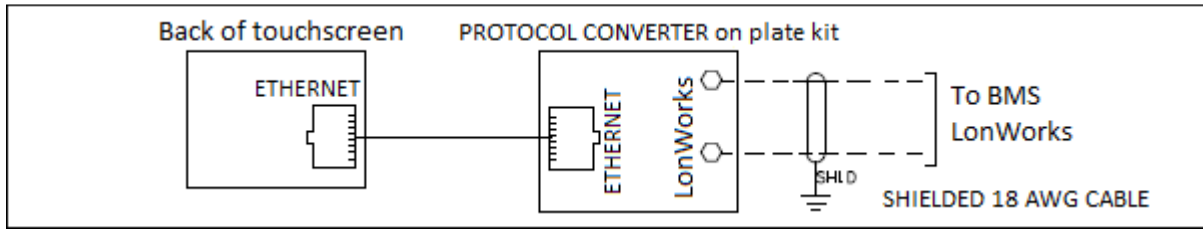

N2 Johnson Metasys, BACnet MS/TP or Modbus RTU

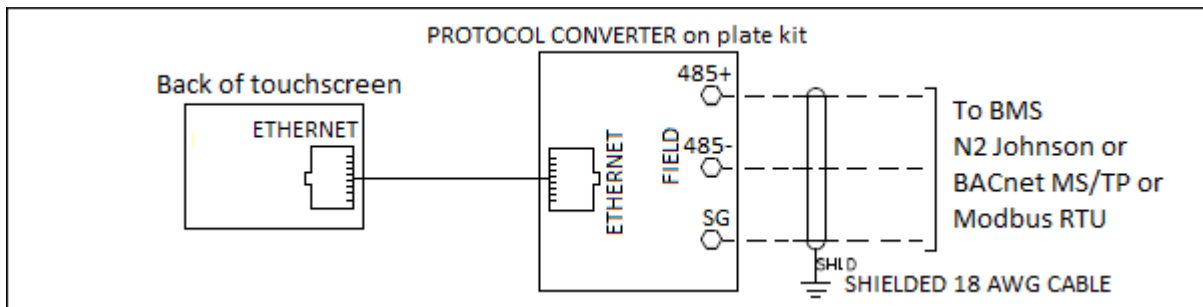

BMS Serial Connection RS232 without Touchscreen

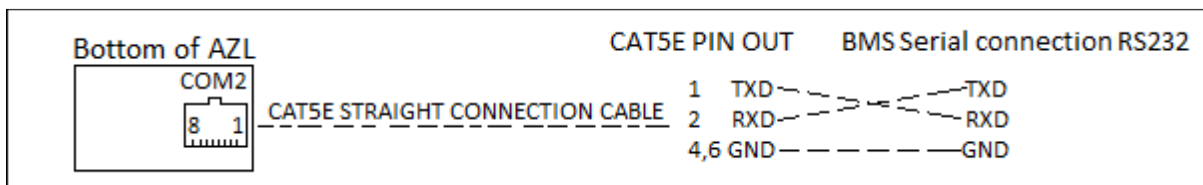

BMS Serial Connection RS485

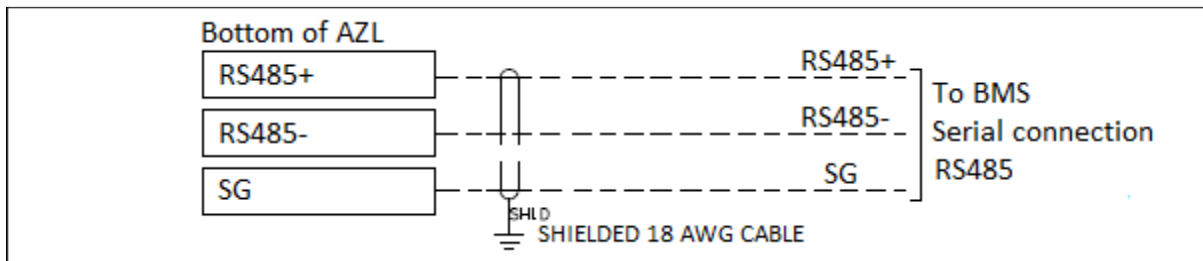

Internal Panel Parts Descriptions (continued)

24" x 24" x 10" Combustion Enclosure

TS-CE22X-x-XXB-Xx2-XXXX

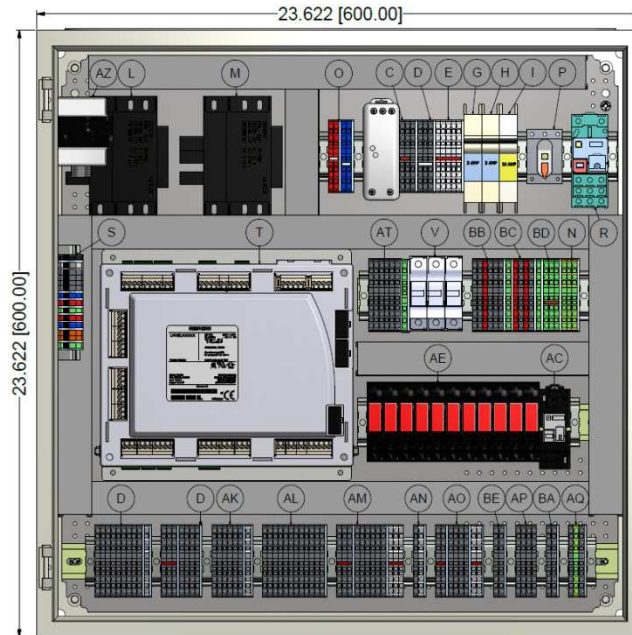

A- N/A	AB- RWF55 load controller LMV51 only(optional)
B- N/A	AC- LMV Lockout Relay
C- 120 VAC H1 power distribution terminals	AD- N/A
D- 120 VAC H2 power distribution Terminals	AE- LMV5 output relays
E- Neutral N1 distribution terminals	AF- N/A
F- N/A	AG- N/A
G- RWF55 water level circuit protection	AH- N/A
H- DC power supply circuit protection	AI- Safety limits field terminals
I- Main power circuit protection	AJ- Running interlocks field terminals
J- N/A	AK- Recycle Limits Field Terminals
K- N/A	AL- Auxiliary devices output terminals
L- AGG5.210 120 VAC to 24 VAC LMV5 transformer	AM- Pilot and gas train field terminals
M- AGG5.210 120 VAC to 24 VAC LMV5 transformer (Optional)	AN- Ignition transformer field terminals
N- Ground GND distribution terminals	AO- Oil train field terminals (Optional)
O- 24 VDC +/- distribution terminals	AP- Flame scanner field Terminals
P- Main disconnect single phase 120VAC 16A/40A	AQ- CANBUS 2 actuators field terminals (optional)
Q- 65W 24 VDC power supply	AR- N/A
R- Power fail relay	AS- N/A
S- RWF55 water level terminals	AT- RS232/RS485 devices connection terminals
T- LMV linkage control and flame safe guard controller	AU- N/A
U- N/A	AV- N/A
V- LMV second transformer fuses and fuse holders	AW- N/A
W- N/A	AX- N/A
X- N/A	AY- N/A
Y- N/A	AZ- Water level SKD actuator 24 VAC transformer (Optional)
Z- N/A	BA- HVAC LMV start command output terminals
AA- BMS Interface Module (BACnet, LON, N2) (Optional)	BB- LMV analog input terminals
	BC- LMV analog Input terminals
	BD- Signal ground terminals
	N- Ground terminals

Internal Panel Parts Descriptions (continued)

32" x 32" x 10" Combustion Enclosure

TS-CE22X-x-E8B-x22-XXXX

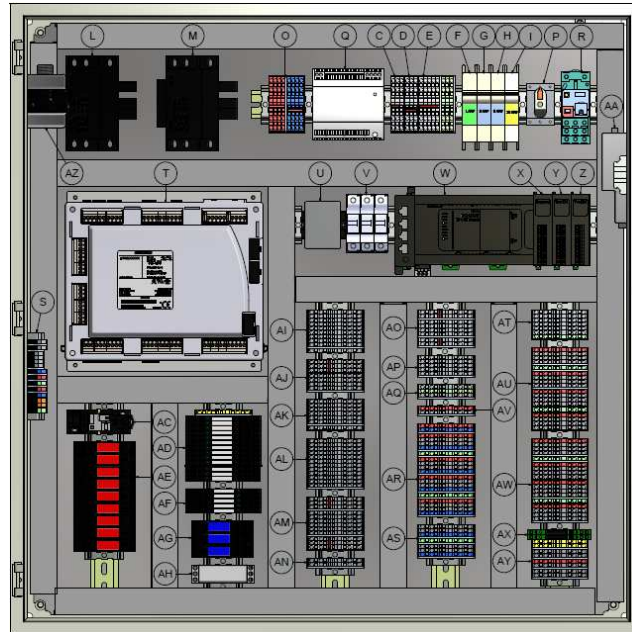

A-	N/A	AB-	RWF55 load controller LMV51 only
B-	N/A	AC-	LMV Lockout Relay
C-	120 VAC H1 power distribution terminals	AD-	Expanded annunciation 13 Relays 120VAC
D-	120 VAC H2 power distribution Terminals	AE-	LMV5 output relays
E-	Neutral N1 distribution terminals	AF-	Circulating pump hot water boilers only, General alarm, PLC health, and monitored digital value output relays
F-	Draft control circuit protection	AG-	Draft control relays (Optional)
G-	RWF55 water level circuit protection	AH-	Draft control high pressure trip time delay timer (Optional)
H-	DC power supply circuit protection	AI-	Safety limits field terminals
I-	Main power circuit protection	AJ-	Running interlocks field terminals
J-	Blower motor, oil pump and compressor motor starters (Optional)	AK-	Recycle Limits Field Terminals
K-	N/A	AL-	Auxiliary devices output terminals
L-	AGG5.210 120 VAC to 24 VAC LMV5 transformer	AM-	Pilot and gas train field terminals
M-	AGG5.210 120 VAC to 24 VAC LMV5 transformer (Optional)	AN-	Ignition transformer field terminals
N-	Ground GND distribution terminals	AO-	Oil train field terminals (Optional)
O-	24 VDC +/- distribution terminals	AP-	Flame scanner field Terminals
P-	Main disconnect single phase 120VAC 16A/40A	AQ-	CANBUS 2 actuators field terminals (optional)
Q-	Up to 95W 24 VDC power supply	AR-	4 Analog Input Field Terminals (Optional)
R-	Power fail relay	AS-	2 Analog output field terminals (Optional)
S-	RWF55 water level terminals	AT-	RS232/RS485 devices connection terminals
T-	LMV linkage control and flame safe guard controller	AU-	4 RTD Inputs field terminals (Optional)
U-	Manual reset LWCO Warrick relay (Optional)	AV-	Circulating pump proven field terminals
V-	LMV second transformer fuses and fuse holders	AW-	4 RTD for economizer inputs field terminals (Optional)
W-	Programmable Logic Controller (PLC) (Optional)	AX-	Draft Damper open/close output relays and draft damper alarm dry contact (Optional)
X-	4 inputs analog input module (Optional)	AY-	Draft control to LMV permissive and shutdowns terminals (Optional)
Y-	4 Inputs RTD Input Module (Optional)	AZ-	Water level SKD actuator 24 VAC transformer (Optional)
Z-	4 Inputs RTD Input module (Optional)	BF-	HVAC LMV start command output terminals
AA-	BMS Interface Module (BACnet, LON, N2) (Optional)		

Internal Panel Parts Descriptions (continued)**42" x 32" x 10" Combustion Enclosure**

TS-CE22X-x-E8B-x22-TDG

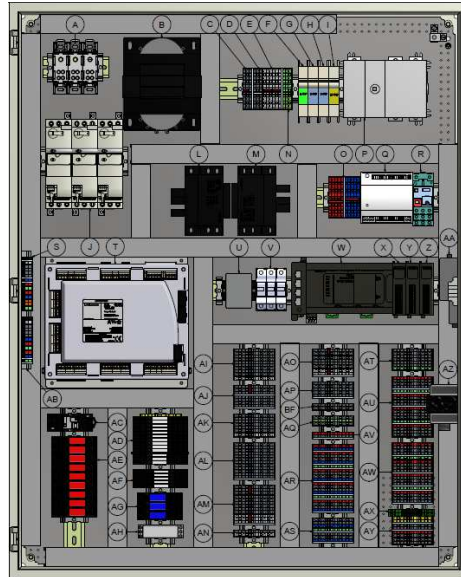

<p>A- Power distribution 3 phase blocks B- 750/1000 VA control transformer (480-120) C- 120 VAC H1 power distribution terminals D- 120 VAC H2 power distribution Terminals E- Neutral N1 distribution terminals F- Draft control circuit protection G- RWF55 water level circuit protection H- DC power supply circuit protection I- Main power circuit protection J- Blower motor, oil pump and compressor motor starters (Optional) K- N/A L- AGG5.210 120 VAC to 24 VAC LMV5 transformer M- AGG5.210 120 VAC to 24 VAC LMV5 transformer (Optional) N- Ground GND distribution terminals O- 24 VDC +/- distribution terminals P- Main three phase 480VAC fused disconnect 30 or 60A Q- Up to 95W 24 VDC power supply R- Power fail relay S- RWF55 water level terminals T- LMV linkage control and flame safe guard controller U- Manual reset LWCO Warrick relay (Optional) V- LMV second transformer fuses and fuse holders W- Programmable Logic Controller (PLC) (Optional) X- 4 inputs analog input module (Optional) Y- 4 Inputs RTD Input Module (Optional) Z- 4 Inputs RTD Input module (Optional) AA- BMS Interface Module (BACnet, LON, N2) (Optional)</p>	<p>AB- RWF55 load controller LMV51 only AC- LMV Lockout Relay AD- Expanded annunciation 13 Relays 120VAC AE- LMV5 output relays AF- Circulating pump hot water boilers only, General alarm, PLC health, and monitored digital value output relays AG- Draft control relays (Optional) AH- Draft control high pressure trip time delay timer (Optional) AI- Safety limits field terminals AJ- Running interlocks field terminals AK- Recycle Limits Field Terminals AL- Auxiliary devices output terminals AM- Pilot and gas train field terminals AN- Ignition transformer field terminals AO- Oil train field terminals (Optional) AP- Flame scanner field Terminals AQ- CANBUS 2 actuators field terminals (optional) AR- 4 Analog Input Field Terminals (Optional) AS- 2 Analog output field terminals (Optional) AT- RS232/RS485 devices connection terminals AU- 4 RTD Inputs field terminals (Optional) AV- Circulating pump proven field terminals AW- 4 RTD for economizer inputs field terminals (Optional) AX- Draft Damper open/close output relays and draft damper alarm dry contact (Optional) AY- Draft control to LMV permissive and shutdowns terminals (Optional) AZ- Water level SKD actuator 24 VAC transformer (Optional) BF- HVAC LMV start command output terminals</p>
--	---

Dimensions

Dimensions in inches; millimeters in brackets

24" x 24" x 10" Combustion Enclosure

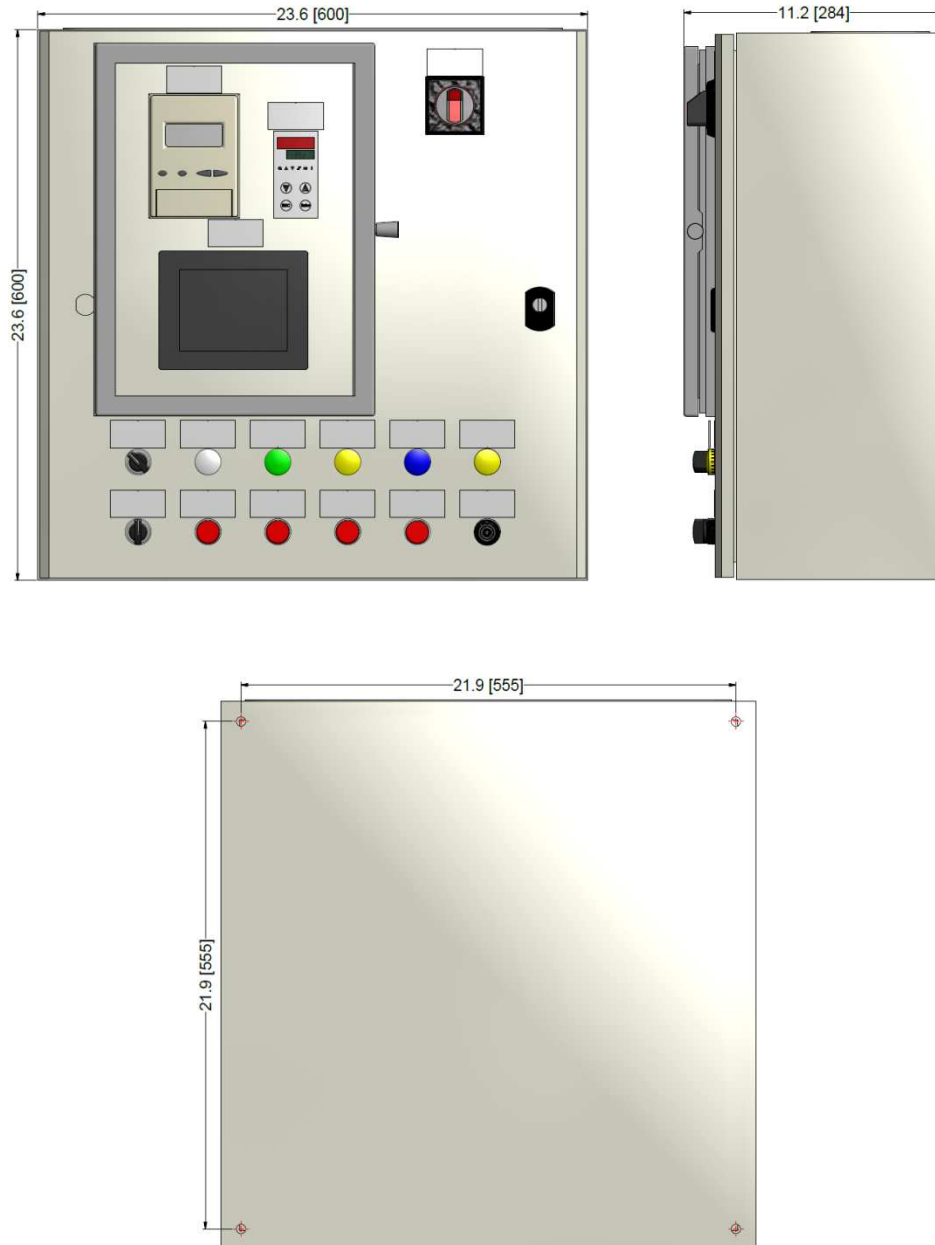

Dimensions (Continued)

Dimensions in inches; millimeters in brackets

32" x 32" x 10" Combustion Enclosure

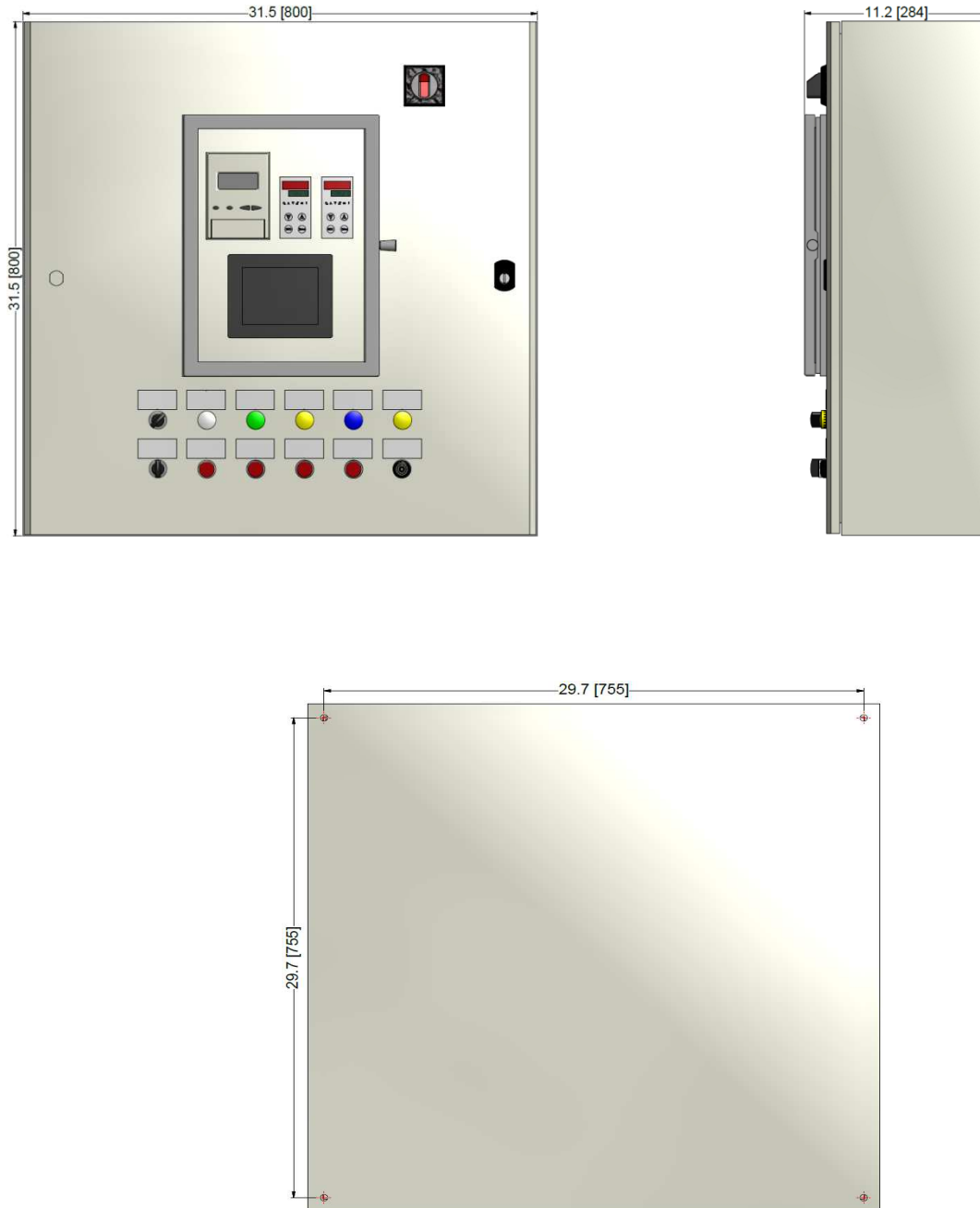

Dimensions (Continued)

Dimensions in inches; millimeters in brackets

40" x 32" x 10" Combustion Enclosure

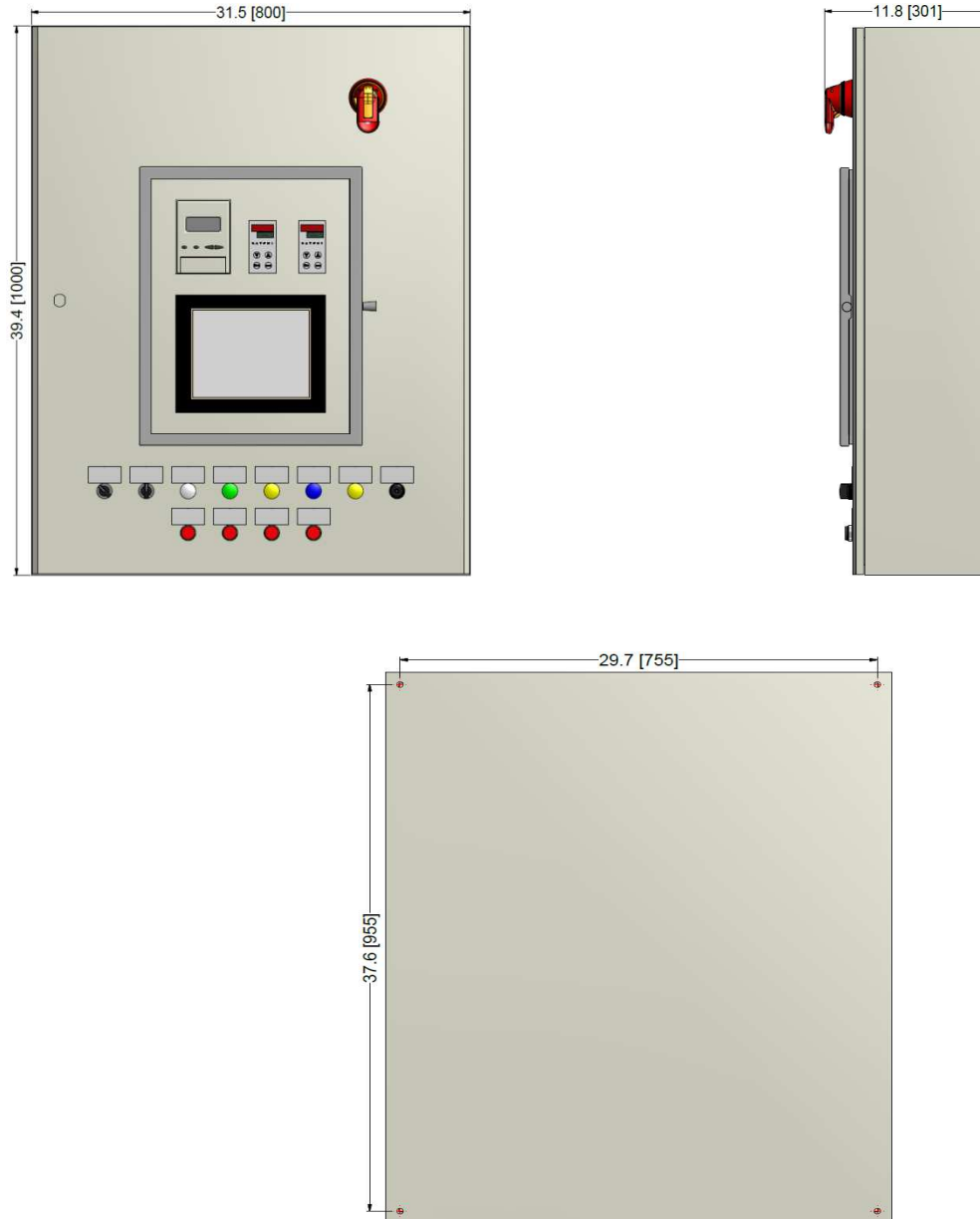

Information in this publication is based on current specifications. The company reserves the right to make changes in specifications and models as design improvements are introduced. Product or company names mentioned herein may be the trademarks of their respective owners. © 2009 SCC Inc.