

## TS Series

---

### TS-MS... Master Lead/Lag Panels for Boiler Management, and Building Management System Interface



---

### Description

A TS-MS... Series Master Lead/Lag Panel sequences and controls up to eight boilers equipped with TS... communication kits and/or TS... combustion enclosures. TS-MS... Master Panel options include communication to TS-D... Deaerator/Surge panel control systems.

A master panel controls hot water or steam boilers with Siemens LMV linkageless control systems with or without an RWF... controller for load or water level control. Each panel includes a 7.5", 10", or 12" touchscreen and Programmable Logic Controller.

Flexible communication interface options to the building management system (BMS) provide streamlined data collection, monitoring and control. Additional options include control of circulating pumps, isolation valves for hot water systems, or monitoring temperatures for steam boilers.

---

## **Standard Features**

- 7.5", 10" or 12" touchscreen
  - Programmable Logic Controller (PLC)
  - Manages up to eight (8) boilers with Siemens LMV... controllers
  - Lead/lag with automatic boiler rotation
  - Lead and lag boiler order selection
  - Parallel or sequential modulation
  - Remote enable and setpoint adjustment via BMS
  - Time/temperature based hot standby
  - Low temperature low fire hold
  - System steam flow or MBTU totalization based upon firing rate
  - Controlling systems with combination TS... touchscreen kits or TS... serial kits at each boiler to Siemens LMV linkageless systems
  - Controlling Systems with or without the RWF for load control or RWF55 for load control
  - Water level monitoring with RWF55 loop controllers
  - Forced lead boiler selection
  - Forced lead boiler to stop boilers rotation
  - Hand-OFF-Auto selection
  - Override setpoint mode via a digital input
  - Boiler firing based on predetermined daily schedule
  - Individual boiler alarms and status
  - Graphics for individual boiler overview screens automatically configure based on master panel selections
  - Individual boiler or master touchscreen picture capture to USB drive
  - Monitored analog outputs can be configured to take an action based upon the value in any of the Modbus registers
  - Monitored digital outputs can be configured to take an action based upon the value in any of the Modbus registers
  - Standard or Metric units display
  - English or Spanish language for display and text for alarms
  - Twelve (12) selectable data logging variables stored in CSV format on USB drive
  - Real time trending and data logging to a USB thumb drive
  - Six (6) selectable variables for trending up to 7 days
  - Alarm history stored for most recent 250 alarms
  - Screen saver with process variable (PV), setpoint and demand
  - Ethernet and Serial communications to local boilers
  - Standard Modbus TCP/IP or RTU to BMS communications
  - Additional BMS communication options available
-

- Email and text messaging for up to six (6) recipients including alarms and screen shots
- Screen shot viewer via USB
- Remote monitoring via mobile device (Such as Smart Phone, tablet, etc.)
- Interface to SCC deaerator/surge tank control panel
- Short cut navigation from the overview screen
- Multi-level, password protected screens
- Four (4) analog inputs with field configurable label, span and type (0-10V, 2-10V, 0-20mA or 4-20mA). Each with low and high alarm setpoints with auto or manual reset. Totalization available per minute or per hour. Optional for hot water boilers
- Two (2) analog outputs with field configurable span and type (0-10V, 2-10V, 0- 20mA or 4-20mA). Each with low and high alarm setpoints with auto or manual reset. Totalization available per minute or per hour. Optional with the analog input module selection for hot water boilers
- Four (4) Pt1000 (or Pt100) RTD temperature inputs with field configurable label. Each with low and high alarm setpoints with auto or manual reset. Optional for steam boilers
- Four (4) digital outputs with field configurable logic, including on and off delays. Manual or automatic reset
- Outside air reset for hot water boilers
- Individual circulating pump control outputs for hot water boilers

---

## Application

TS-MS Lead/Lag Panels are engineered for hot water boilers, steam boilers or other applications utilizing LMV3 or LMV5 linkageless control systems with or without RWF for load or water level controls.

---

## Components

All TS-MS... Master Panels include the following components:

- 7.5", 10" or 12" touchscreen
  - Programmable Logic Controller (PLC)
  - Power supply and branch circuit protection
  - Digital, analog, and RTD input modules
  - Analog and digital inputs and outputs
  - Interconnect terminals for field wiring
-

## Product Part Numbers

For Master Lead/Lag Panel part number identification.

	TS	-	MS	8	1	0	S	-	S	X	X
Touchscreen											
Master Lead/Lag											
Number Of Boilers											
4 = Up to four boilers and SCC DA/Surge Panel											
5 = Up to five boilers											
7 = Up to seven boilers and SCC DA/Surge Panel											
8 = Up to eight boilers											
9 = Up to eight boilers and SCC DA/Surge Panel											
Enclosure											
1 = NEMA 1 / NEMA 4X standard											
2 = NEMA 12 includes touchscreen window cover											
3 = NEMA 1 with fan cooling											
4 = NEMA 12 with fan cooling includes touchscreen and fan cover											
5 = NEMA 4/4X with fan cooling includes fan cover											
Touchscreen Size											
7 = 7.5" touchscreen											
0 = 10" touchscreen											
2 = 12" touchscreen											
BMS Communication											
S = Modbus TCP/IP and Modbus RTU 485											
B = BACnet IP,											
L = LONWORKS											
M = BACnet MS/TP, or Johnson Metasys N2											
N = ProfiNet											
P = Profibuss											
Application											
S = Steam boilers with touchscreen kits at each boiler											
H = Hot water boilers with touchscreen kits at each boiler											
R = Steam boilers with serial kits at each boiler											
W = Hot water with serial kits at each boiler											
U = Universal steam boilers with touchscreen kits and serial kits at each boiler											
Z = Universal hot water boilers with touchscreen kits and serial kits at each boiler											
Temperature Measurement for Steam Boilers or Analog Measurement for Hot Water Boilers											
T = 4 Platinum 100/1000 Ohms RTD inputs (only for selection S, R, or U application above)											
A = 4 analog inputs module (only for selection H, W, or Z application above)											
X = None											
Circulating Pump Controls (Hot water applications H,W, or Z only)											
Y = Circulating pump controls (based on number of boilers selected above up to 8 outputs)											
X = None											

## Specifications

		<b>7.5"</b> <b>Touchscreen</b>	<b>10"</b> <b>Touchscreen</b>	<b>12"</b> <b>Touchscreen</b>
Electrical characteristics	Operating Voltage	110- 120 VAC	110-120 VAC	110-120 VAC
	Operating Frequency	50-60 HZ	50-60 HZ	50-60 HZ
	Touchscreen power	24 VDC	24 VDC	24 VDC
	Power consumption	≤ 6.8 W	≤ 17 W	≤ 19 W
	Dry contacts	2 Amps	2 Amps	2 Amps
Operating environment	Operating temperature	32 to 122 °F [0 to 50 °C]	32 to 131 °F [0 to 55 °C]	32 to 131 °F [0 to 55 °C]
	Humidity	Max. 80% with no condensation	Max. 85% with no condensation	Max. 85% with no condensation
	NEMA rating (Standard) NEMA rating (Optional)	1, 4, 4X (indoor only) NEMA 12	1, 4, 4X (indoor only) NEMA 12	1, 4, 4X (indoor only) NEMA 12
Field cables (By others)	Between master and boiler touchscreens Between master and serial kits (no touchscreens)	CAT5e-CAT6-CAT6e-CAT7  Belden 3106A recommended		
BMS cable length	Modbus RTU RS-232 connection Modbus RTU RS-485 connection  All Other Protocols	Up to 15 feet  Up to 1500 feet  Adhere to BMS protocol wiring specifications		

---

## Specifications (continued)

**Note:** For all RS-485 connections, use Belden cable 3106A (multi-conductor cable with twisted pair, EIA Industrial RS-485 PLTC/COM) or equivalent.

**Table 1: Belden Cable 3106A Wire Color Designation**

<b>Electrical Diagram</b>	<b>Belden Cable 3106A</b>
Red (RS485+)	Orange (RS485+)
Black (RS485-)	White (RS485-)
White (SG)	Blue (SG)

## Connections

### Power Connections

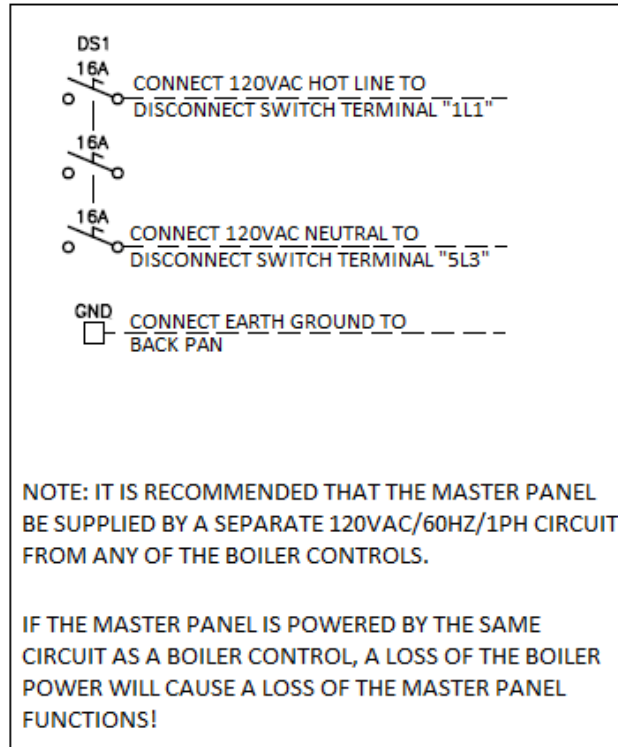

### Digital Input Remote Control Terminals

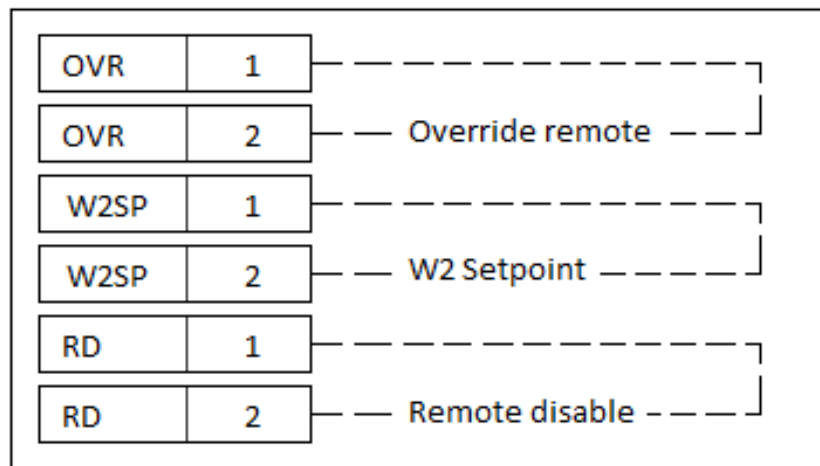

## Connections (continued)

### Outputs Monitored Value and Circulating Pump Terminals

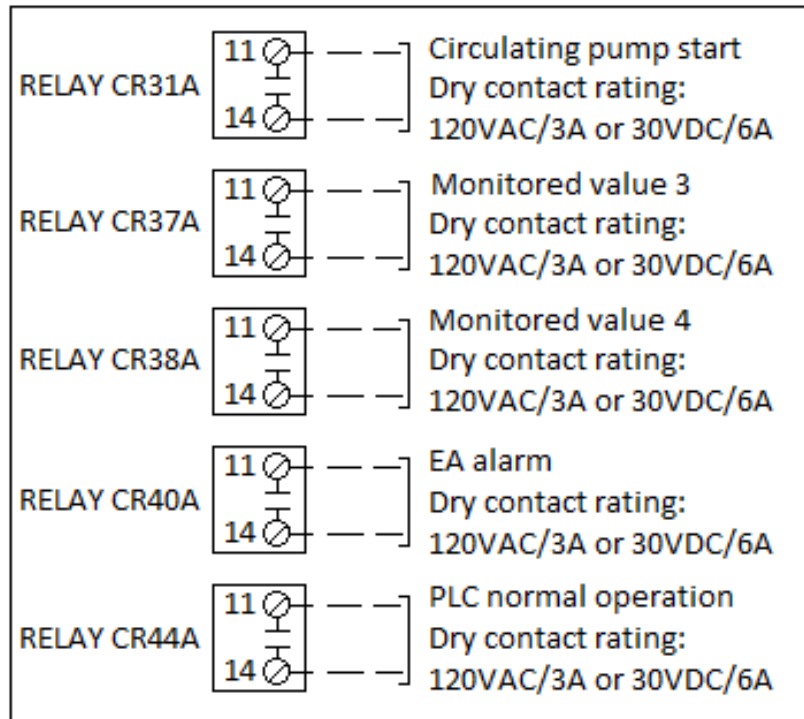

## Connections (continued)

### Hot Water Boilers Only (Application H, W or Z): Digital Input Pump Proven Terminals

**Note:** Number of boilers in the part number corresponds to the number of wired digital inputs for pump proven terminals

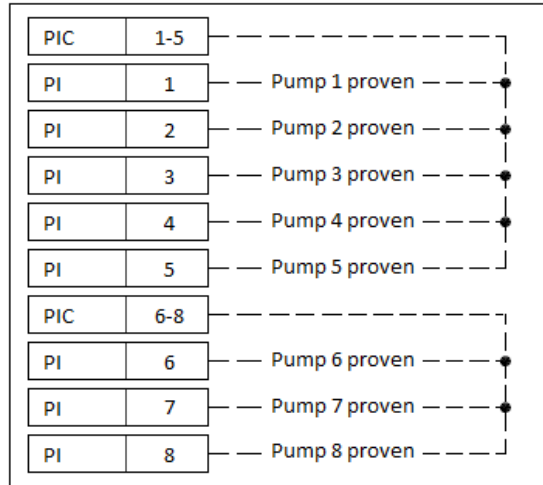

### Hot Water Boilers Only (Application H, W, or Z): Digital Output Pump Control Terminals

**Note:** Number of boilers in the part number corresponds to the number of wired digital outputs for pump control terminals

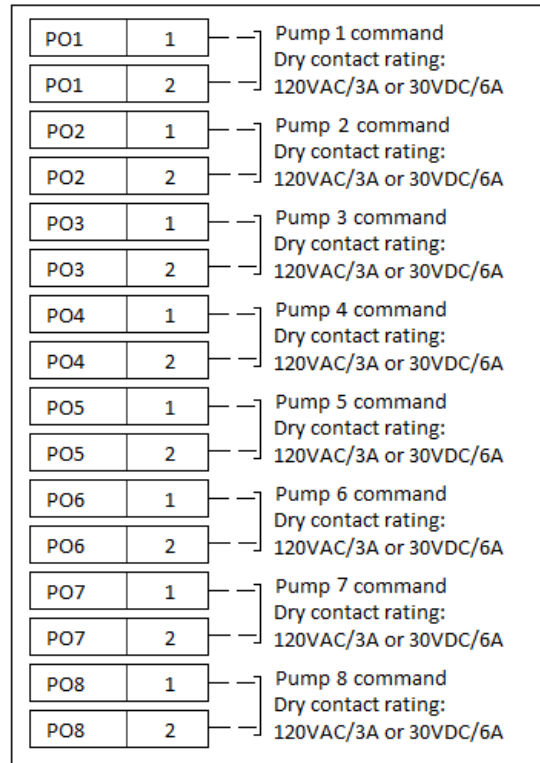

## Connections (continued)

### Analog Input and Output Terminals (one module)

Standard for Steam Boilers (Application S, R, or U)

Optional for Hot Water Boilers (Application H, W or Z)

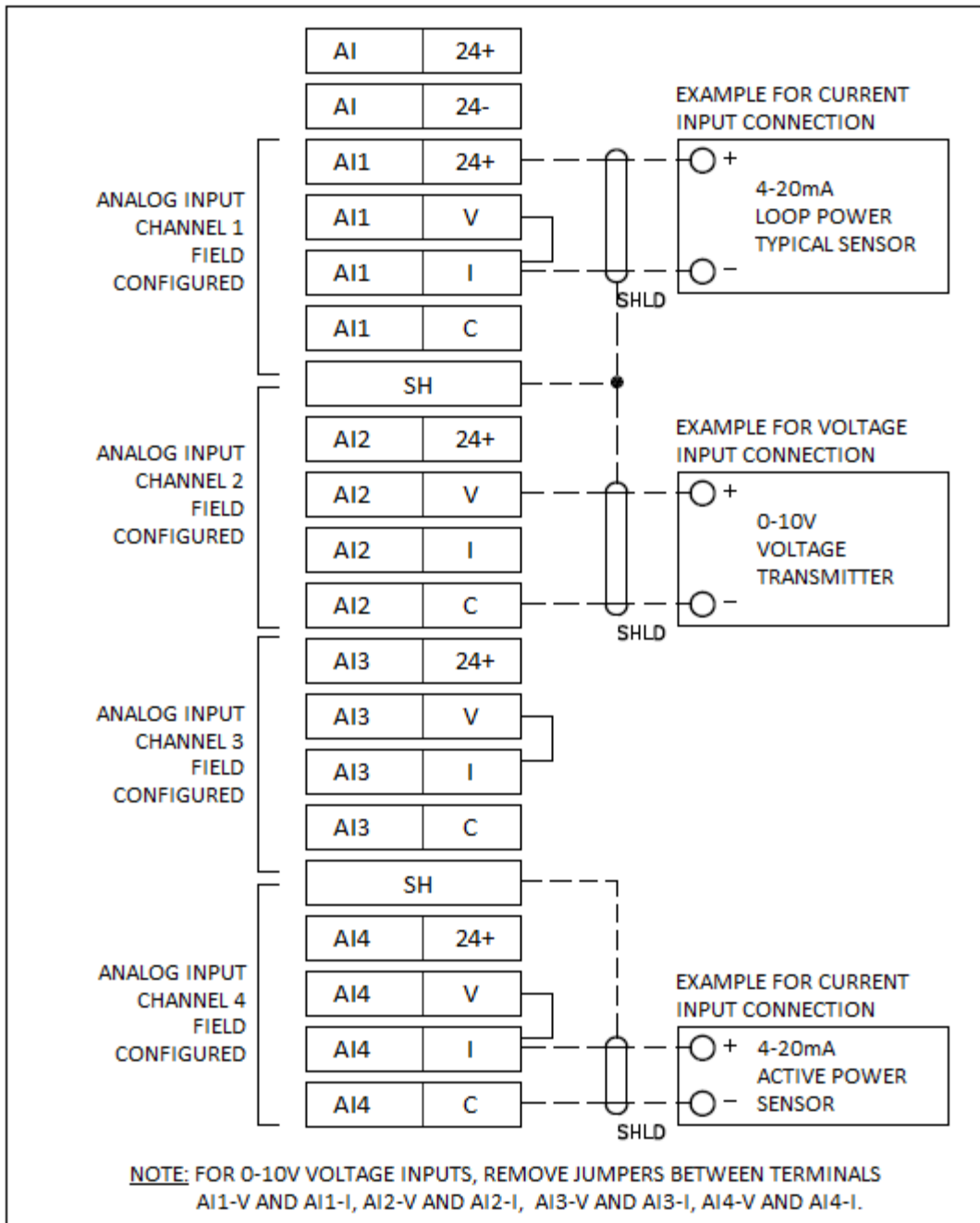

## Connections (continued)

### Analog Inputs and Outputs Terminals (one module) Continued

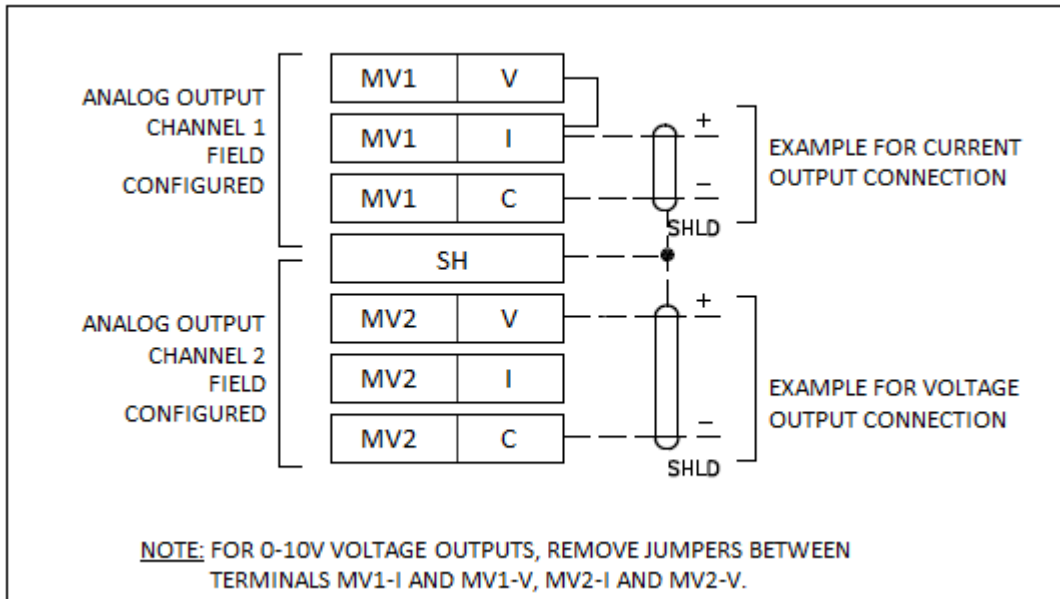

## Connections (continued)

### RTD Input Terminals

Standard for Hot Water Boilers (Application H, W or Z)

Optional for Steam Boilers (Application S, R, or U)

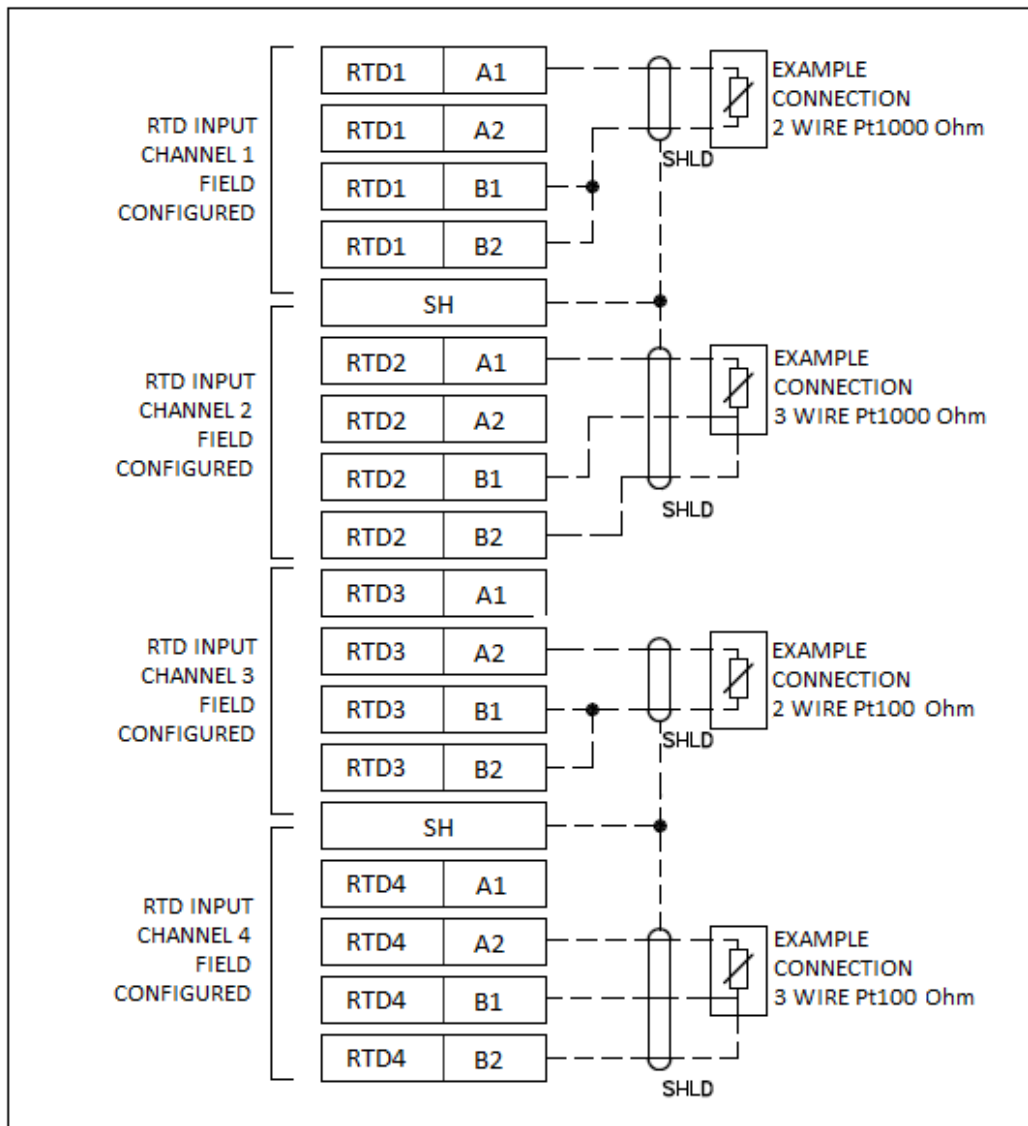

## Connections (continued)

### Ethernet Connection with TS Kits at Each Boiler and Deaerator/Surge (if applicable)

**NOTE: Wire all the cat5e cable separately from AC power wires.**

**Ethernet connection with up to 5 TS kits or up to 4 TS kits and DA/SRG. Ethernet Cable not included.**

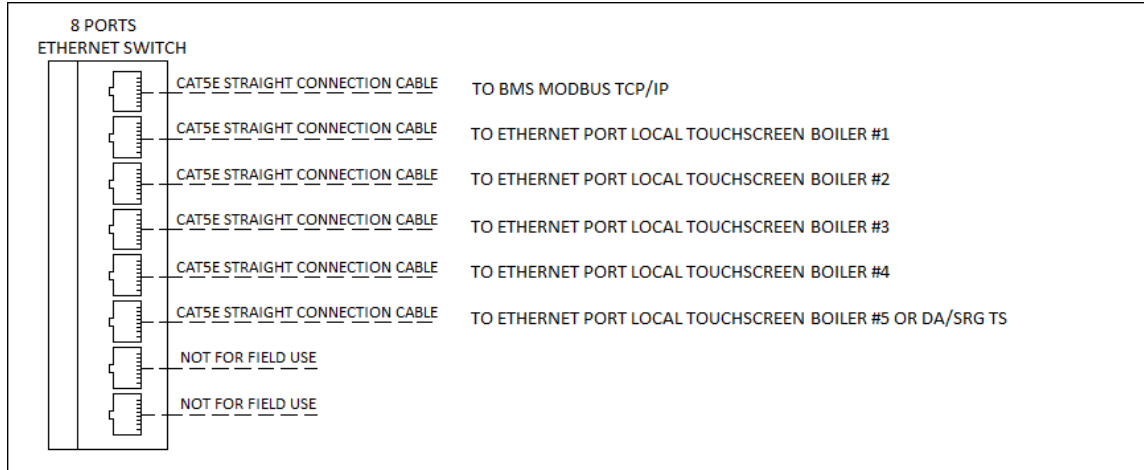

### Ethernet connection with up to 8 TS kits or up to 7 TS kits and DA/SRG

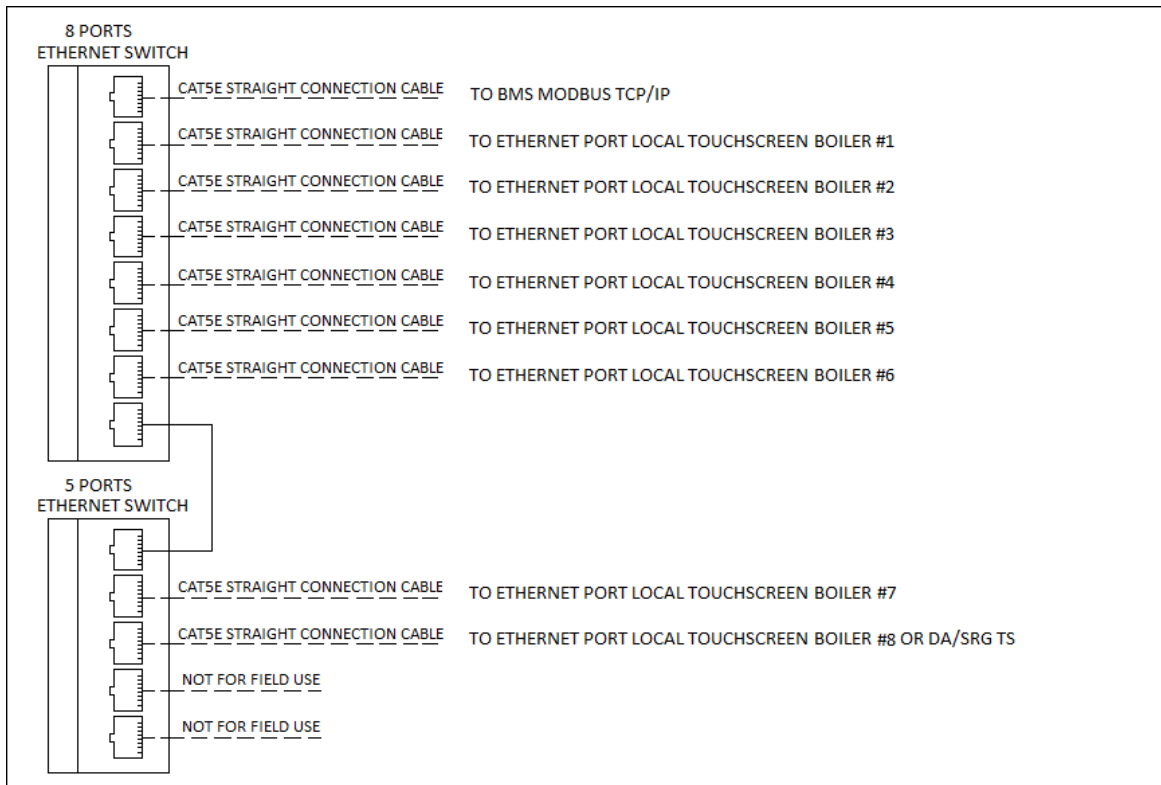

## Connections (continued)

### Ethernet connection with up to 8 TS kits and DA/SRG

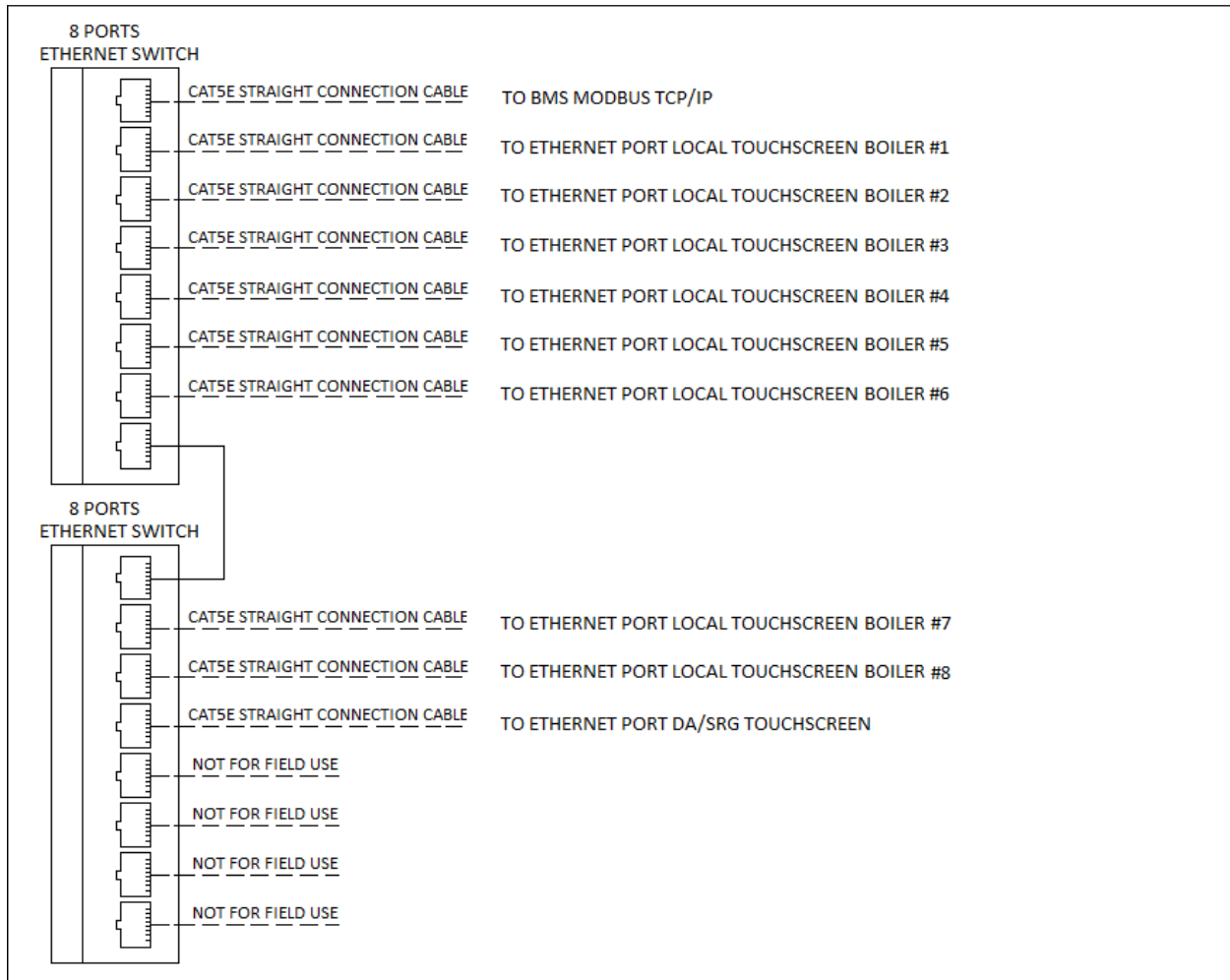

## Connections (continued)

### Modbus RS-485 Serial Connection with LMV52 Serial Kits (no touchscreen at each boiler)

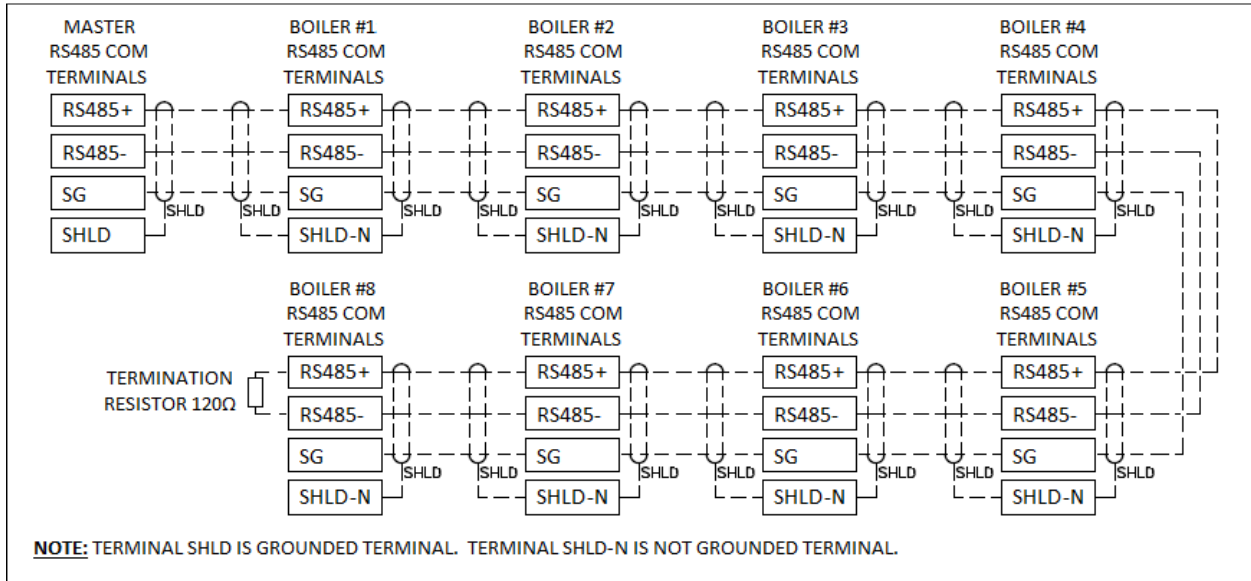

## Connections (continued)

**Modbus RS-485 Serial Connection with LMV51 Serial Kits (no touchscreen at each boiler) and with RWF55 as Load Controller (LC)**

Or

**Modbus RS-485 Serial Connection with LMV52/51 Serial Kits (no touchscreen at each boiler) and with RWF55 as Water Level Controller (WL)**

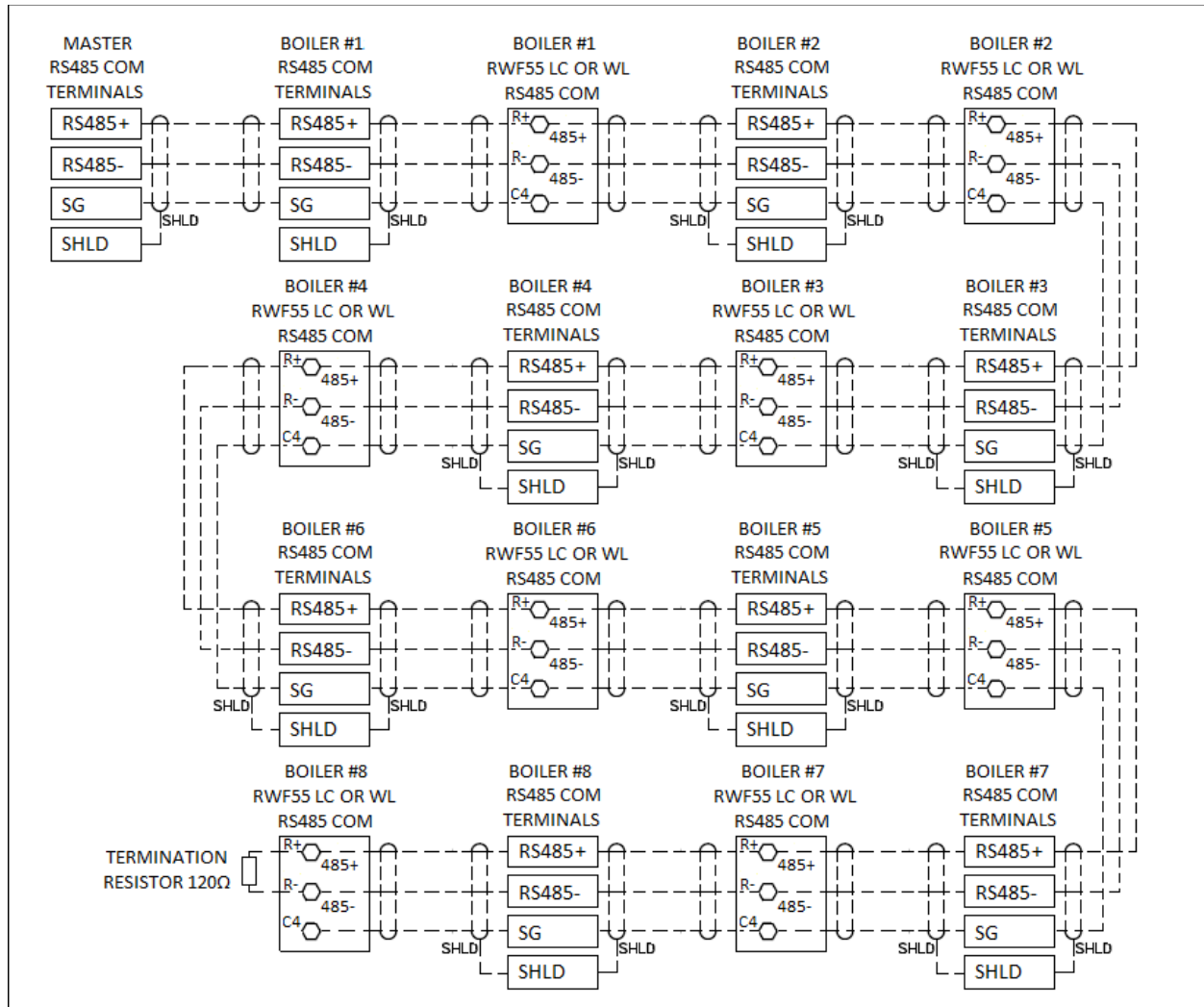

## Connections (continued)

**Modbus RS-485 Serial Connection with LMV3x Serial Kits (no touchscreen at each boiler) and with RWF55 as Load Controller (LC)**

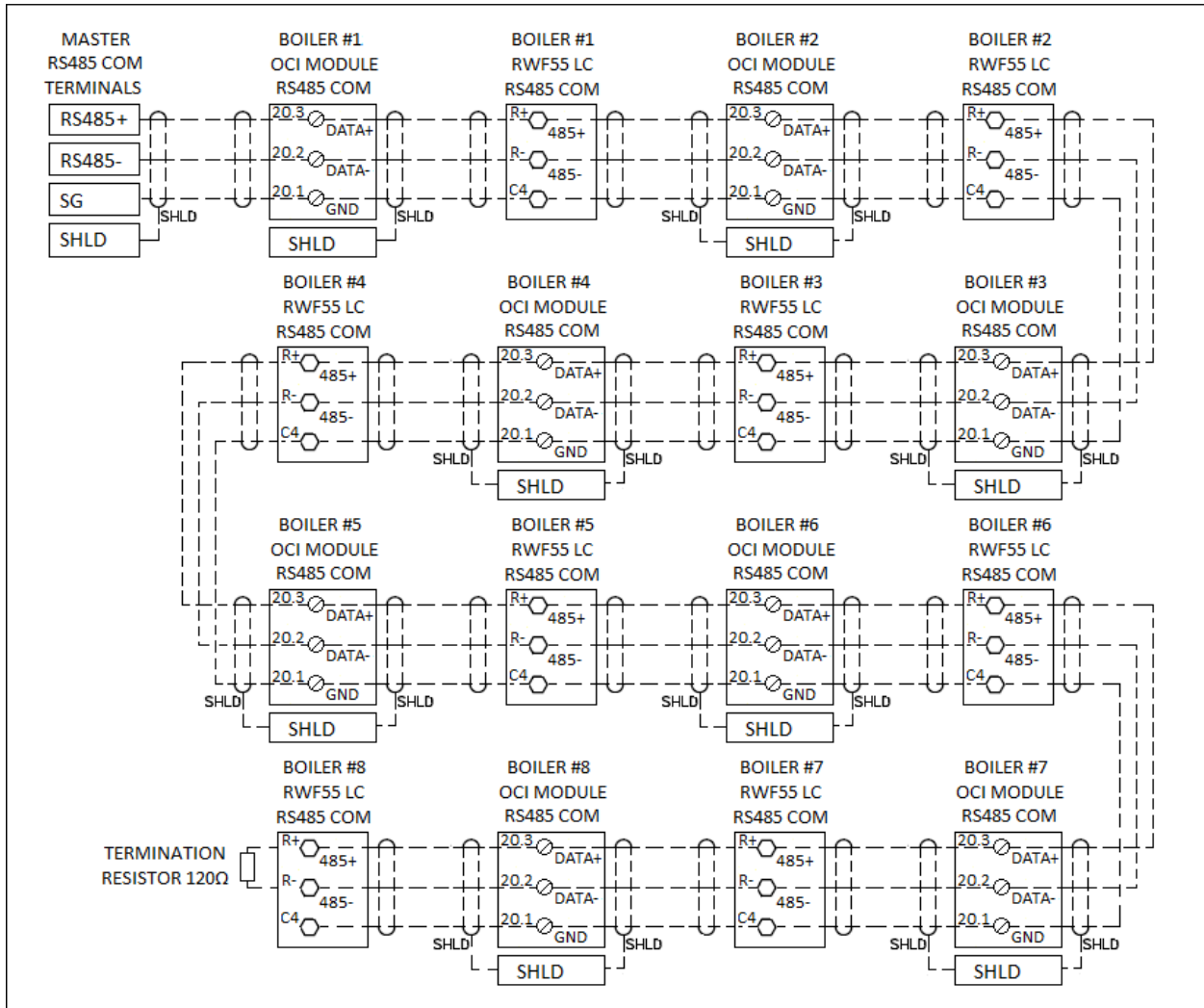

## Connections (continued)

Modbus RS-485 Serial Connection with LMV3x Serial Kits (no touchscreen at each boiler) and with RWF55 as Load Controller (LC), and RWF55 as Water Level Controller (WL)

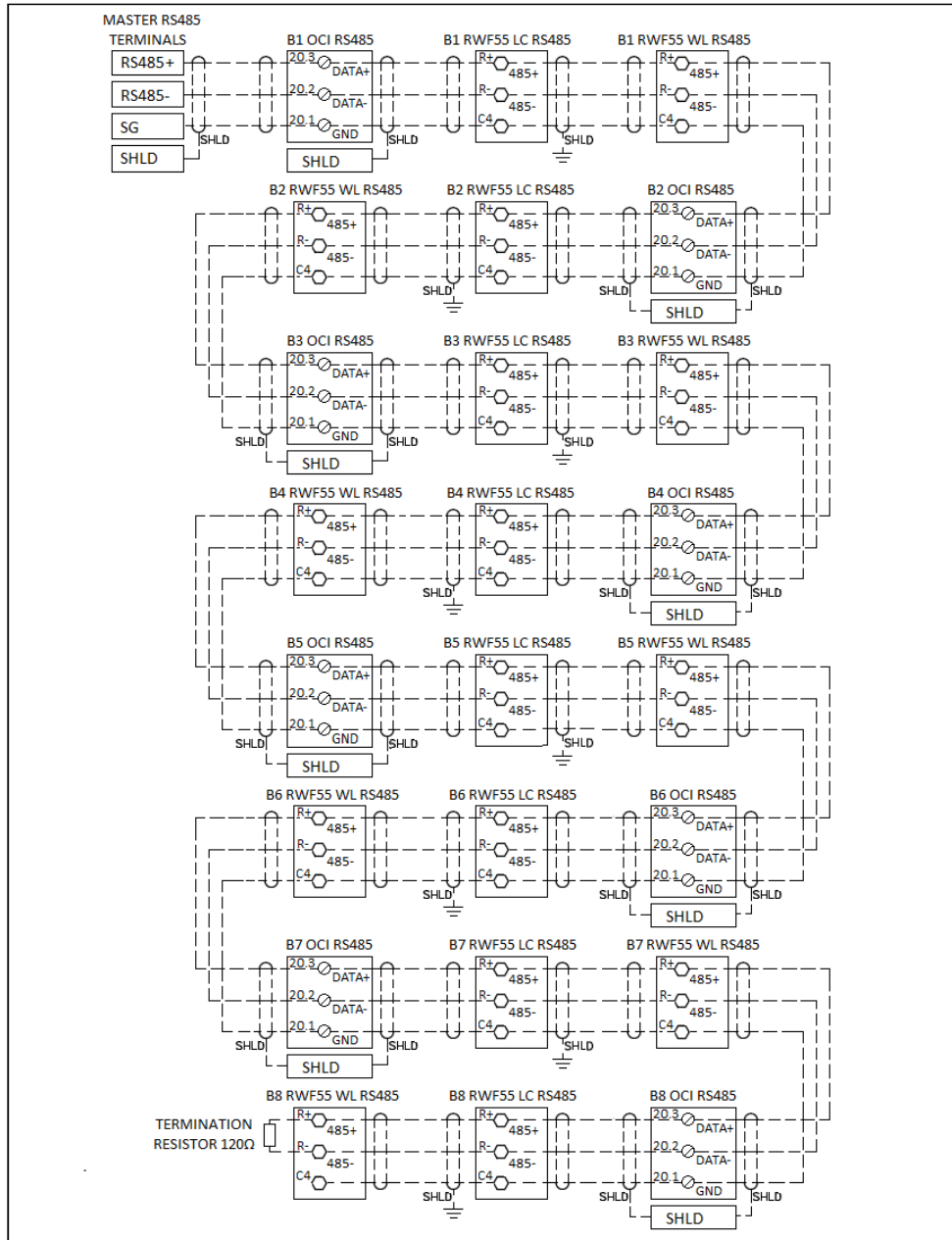

## Connections (continued)

**Modbus RS-485 Serial Connection with LMV3x Serial Kits (no touchscreen at each boiler) and with RWF10 as Load Controller (LC)**

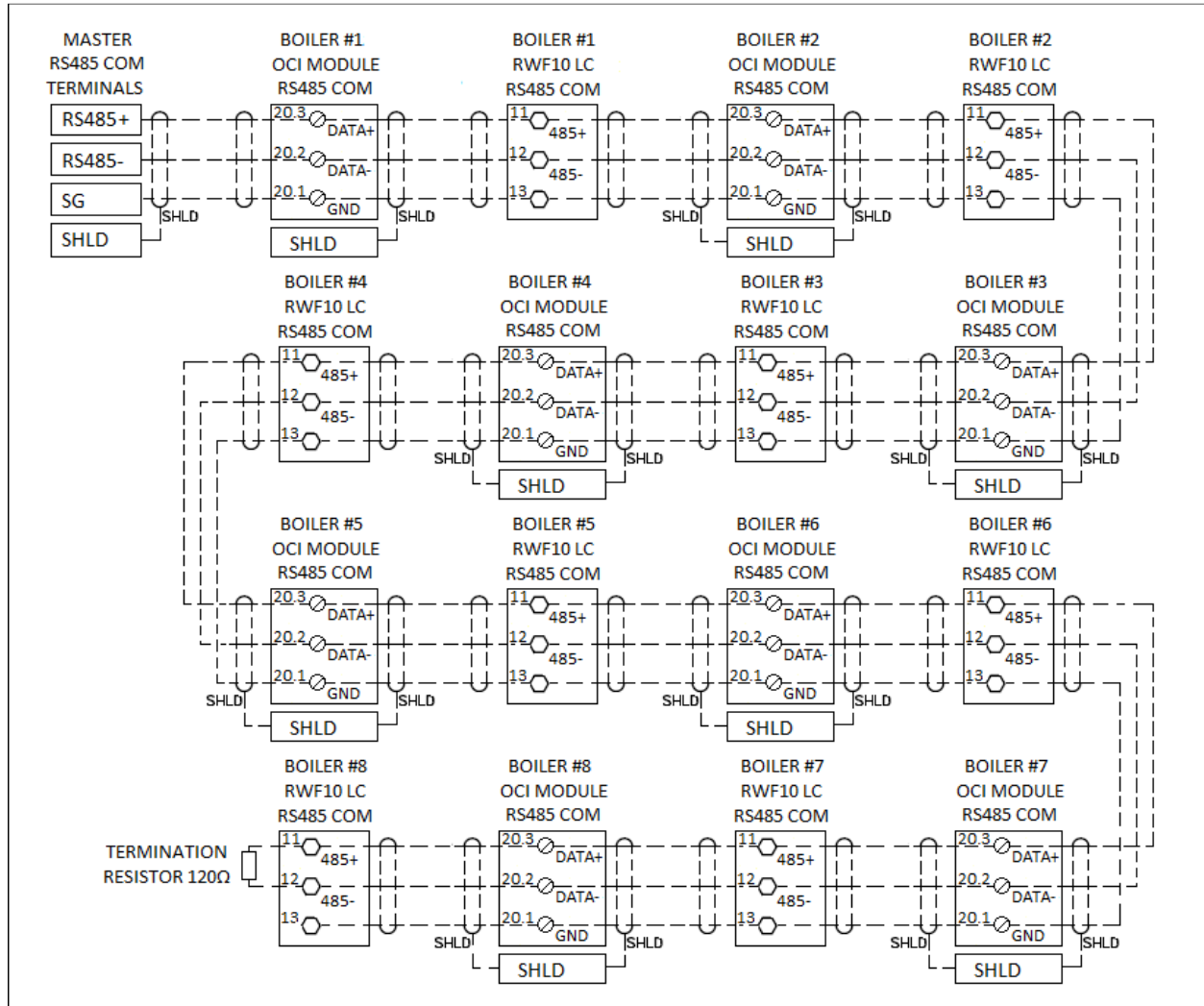

## Connections (continued)

Modbus RS-485 Serial Connection with LMV3x Serial Kits (no touchscreen at each boiler), and with RWF10 as Load Controller (LC), and RWF55 as Water Level Controller (WL)

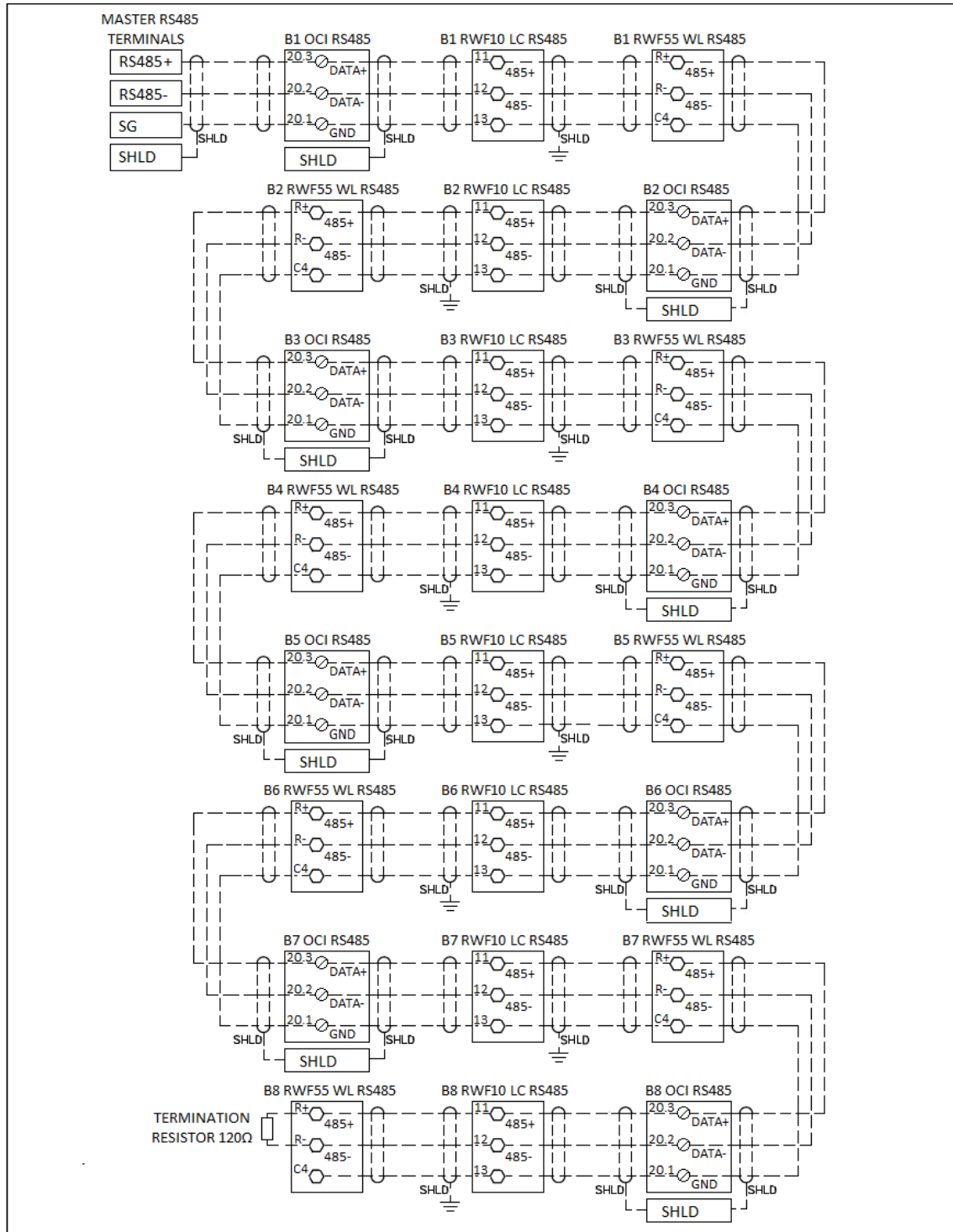

## Connections (continued)

### BMS Communications Connections

Standard Modbus TCP/IP



Standard Modbus RTU RS232

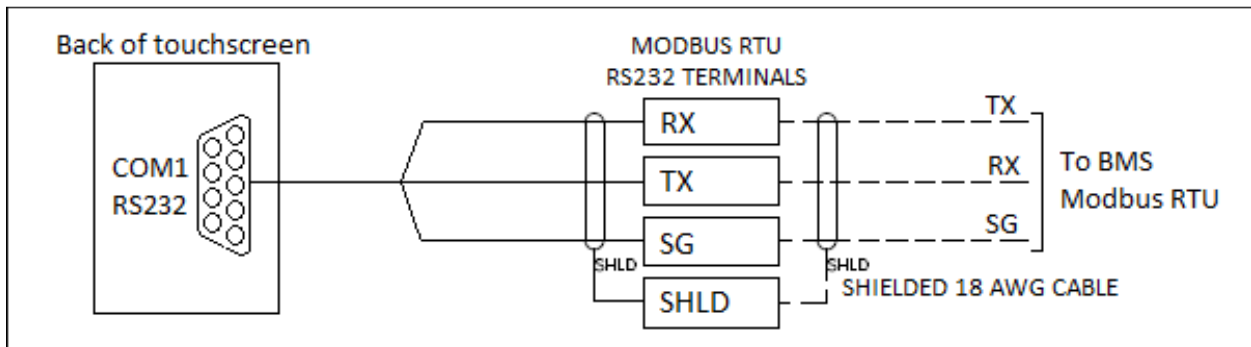

Standard Modbus RTU RS485

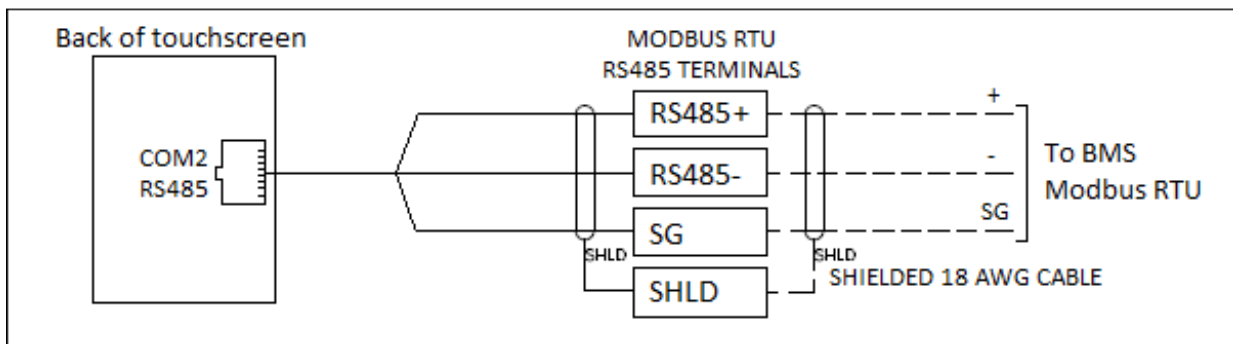

## Connections (continued)

### BMS Communications Connections

N2 Johnson, BACnet MS/TP, BACnet/IP, or Modbus TCP/IP

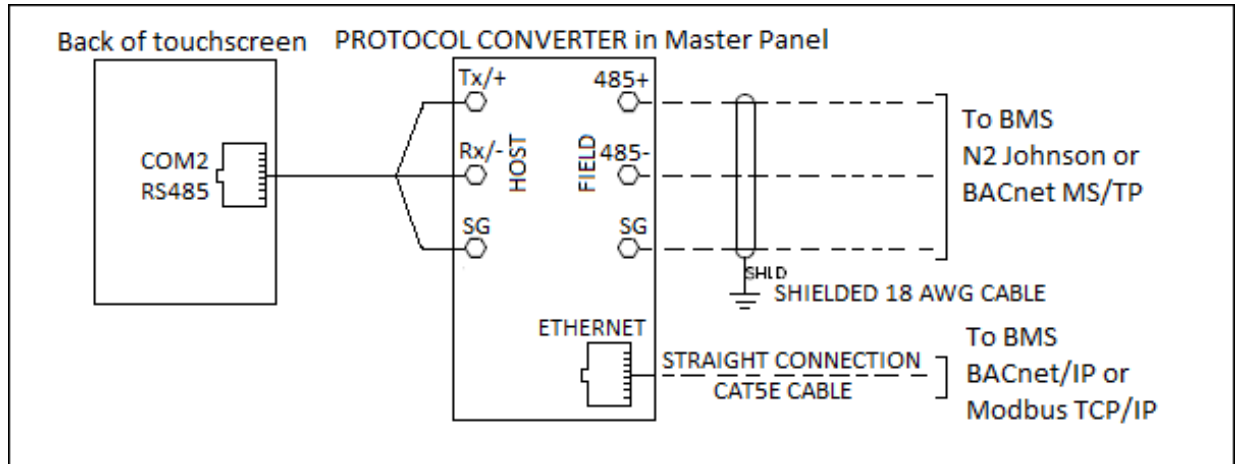

Lonworks

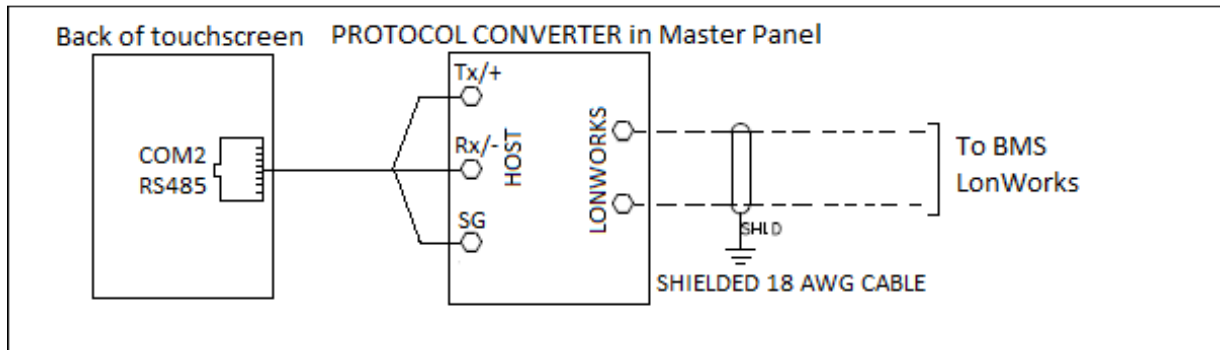

## Enclosure Parts Description

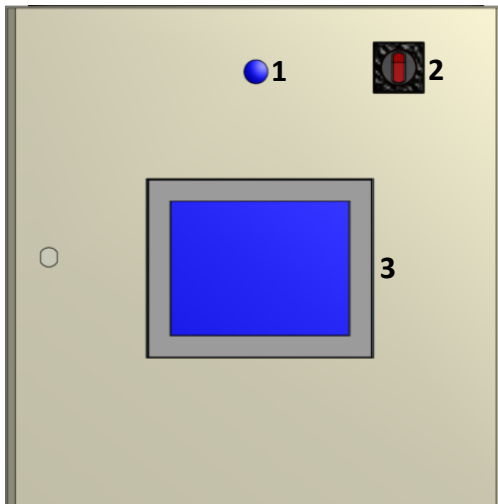

**Front**

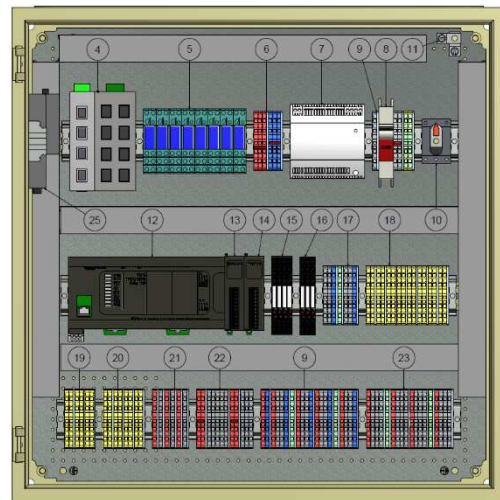

**Back Pan**

- 1- 24 VDC PLC normal indicator light
- 2- Main 120 VAC lockable disconnect handle
- 3- 7.5", 10" or 12" Schneider touchscreen
- 4- Ethernet switch, number of ports dependent upon product part number
- 5- Circulating pump and isolation valves output relays, only if circulating pump controls option (Y) is selected for hot water boilers (Application H, W, or Z)
- 6- 24 VDC enclosure terminals
- 7- 24 VDC power supply
- 8- Circuit breaker
- 9- 120 VAC power terminals
- 10- 120 VAC main disconnect with UL lock
- 11- Ground lugs
- 12- Schneider Programmable Logic Controller (PLC)
- 13- Analog input module
- 14- RTD input module - standard for hot water boilers (Application H, W, or Z); included if RTD option (T) is selected for steam boilers (Application S, R, or U)
- 15- Monitored value discrete output Relays
- 16- General and analog high/low alarm relays
- 17- Analog output field terminals
- 18- Circulating pumps control field terminals, standard for water boilers only (Application H, W, or Z)
- 19- General, PLC normal, high and low analog inputs alarm field terminals
- 20- Monitored value discrete output field terminals
- 21- Override, remote set point, and remote disable field terminals
- 22- Circulating pump proven field terminals for hot water boilers only (Application H, W, or Z)
- 23- RTD input terminals - standard for hot water boilers (Application H, W, or Z), optional for steam boilers (Application S, R, or U)
- 24- Analog input field terminals
- 25- BMS interface module for communications other than Modbus (Options B, M, or L)

## Enclosure Dimensions

Dimensions in inches; millimeters in brackets

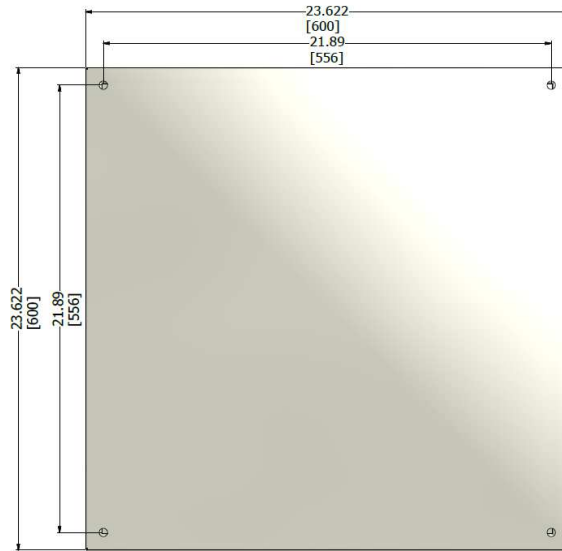

**Back**

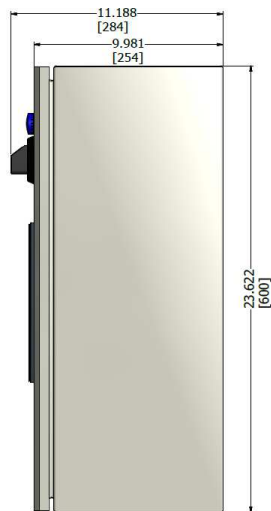

**Side (NEMA 1/NEMA 4X)**

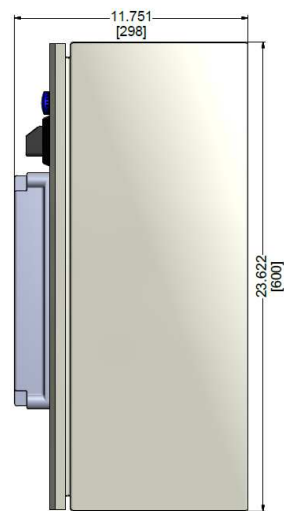

**Side (NEMA 12 with cover)**

Information in this publication is based on current specifications. The company reserves the right to make changes in specifications and models as design improvements are introduced. Product or company names mentioned herein may be the trademarks of their respective owners. © 2009 SCC Inc.