

Powermite 599

MT Series SAS Electronic Valve Actuator 24 Vac or 24 Vdc, Proportional Control



SAS61.03U



SAS61.33U

Description The Powermite 599 MT Series SAS Electronic Valve Actuator requires a 24 Vac or 24 Vdc supply and receives a 0 to 10 Vdc or a 4 to 20 mA control signal to proportionally control a valve. This actuator is designed to work with Powermite 599 MT Series terminal unit valve with a 7/32-inch (5.5 mm) stroke.

- Features**
- Maintenance-free with reversible motor.
 - Position indicator.
 - UL listed for plenum installations.
 - 0 to 10V or 4 to 20 mA.
 - LED status indicator.
 - Auto calibration
 - Position output signal 0 to 10 Vdc.
 - Manual positioning knob with stroke indication allows for repositioning.
 - Mechanical spring returns the valve to its normal (fail-safe) position in power-off conditions (SAS61.33U Actuator only).

Application For use in small to medium HVAC installations with Powermite 599 Series terminal unit valves with a 7/32-inch (5.5 mm) stroke requiring a minimum of 90 pounds force (400N). They can be used in liquid and low pressure steam service applications.

Table 1. Ordering Information.

Product Numbers	Product Number	Actuator type	Actuator Prefix Code
	SAS61.03U	Non-Spring Return (Fail-in-place)	364
	SAS61.33U	Spring Return (Fail-safe)	365

Ordering Information To order a complete valve plus actuator assembly from the factory, combine the actuator prefix code with the suffix of the valve product number. See TB 251 *Powermite 599 Series MT Series Terminal Unit Valve and Actuator Assembly Selections Technical Bulletin* (155-306P25) for selection procedures.

To order an actuator only, use the product number in Table 1.

Specifications			
Power Requirements	Operating voltage	24 Vac \pm 20%, 24 Vdc, + 20%, -15%	
	Frequency	45 to 65 Hz	
	Power supply	Earth ground isolating, Class 2, 24V transformer, 100 VA max.	
	Power consumption - running		
	SAS61.03U	5.3 VA	
	SAS61.33U	5.9 VA	
Control Characteristics			
	Terminal Designation		
	Y	Control Signal Current draw	0 to 10 Vdc, 4 to 20 mA \leq 0.1 mA for 0 to 10 Vdc control 4 to 20 mA \pm 1% for 4 to 20 mA control
		Input impedance	>100K ohms
	U	Position feedback	
		Voltage	0 to 10 Vdc \pm 1%
		Load impedance	>10K Ω res.
		Current load	1 mA max.
	Z	Forced control	
		Resistance	0 to 1000 Ω , stroke proportional to R
		Z connected to G	Max. stroke 100%
		Z connected to G0	Min. stroke 0%
		Voltage	Max. 24 Vac to 20%, Max 24 Vdc+20%,-15%
		Current draw	\leq 0.1 mA
Functional Operation			
	Running time		
	at 60 Hz		30 seconds
	Spring return (SAS61.33U only)		<14 seconds
	Nominal stroke		7/32-inch (5.5 mm)
	Nominal Force		90 lbs. (400N)
	Spring return (SAS61.33U only)		Mechanical spring
Agency Approvals			
	UL		UL873
	cUL		Certified to CSA C22.2 No. 24-93
Environmental Conditions			
	Ambient temperature		
	Operation		23°F to 131°F (-5°C to 55°C)
	Transport and storage		-13°F to 158°F (-25°C to 70°C)
	Humidity		<95% rh
	Max. permissible media temperature in valve		34°F to 248°F (1°C to 120°C)
Physical Characteristics			
	Conduit opening		Knockouts for standard 1/2-inch conduit connector
	Weight		
	SAS61.03U		0.9 lbs. (0.4 kg)
	SAS61.33U		1.5 lbs. (0.68 kg)
	Dimensions		See Figure 4 and Figure 5.

Accessory

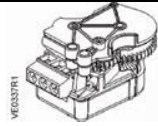

Auxiliary Switch ASC10.51 switches on or off when a certain position is reached. The switching point can lie between 0 to 100%.

Service Kit

If the actuator is inoperative, replace the unit.

Operation

A zero voltage control signal returns the valve to its normal position.

In the event of a power failure:

- SAS61.03U is non-spring return and holds its last position.
- SAS61.33U returns the valve to its normal spring return position.

The position output 0 to 10 Vdc signal “U” produces position feedback to the controller.

Mounting and Installation

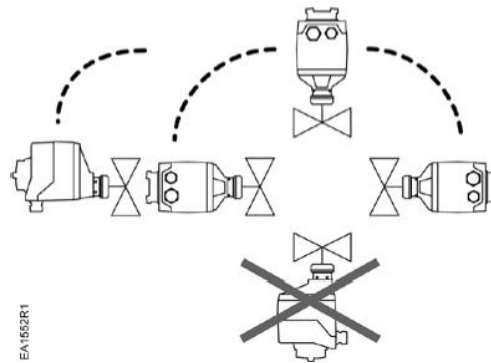

Figure 1. Acceptable Mounting Positions.

Mount the actuator in any position *except* with the actuator lower than the valve. Figure 1 shows acceptable actuator mounting positions for water applications. The recommended mounting position of the actuator for low pressure steam applications is between 45° and horizontal.

Wiring

- All units using the same control signal must utilize the same neutral reference (G0).
- Use earth ground isolating, step-down Class 2 transformers. Do *not* use auto transformers.
- Determine supply transformer minimum rating by summing the total equipment on circuit. The maximum rating for Class 2 step-down transformers is 100 VA.
- Do *not* power more than 10 actuators with one transformer.



WARNING:

Housing rated for flex conduit only.

Wiring Diagrams

G0	Neutral (-)
G	Hot (+)
Y	Positioning signal for 0 to 10 Vdc/4 to 20 mA
M	Measuring neutral
U	Position feedback 0 to 10 Vdc
Z	Positioning signal forced control AC/DC $\leq 24V$, 0 to 1000 Ω

Figure 2. Terminal Connections.



WARNING:

Terminal connection G is 24 Vac HOT, not ground.



CAUTION:

G0 and G must be properly wired for correct function and full life of the actuator.

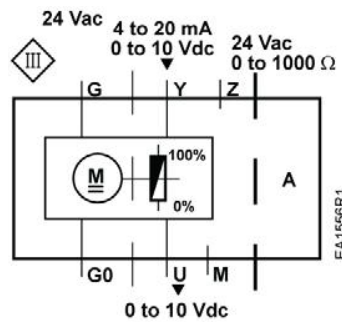

Figure 3. Wiring Diagram.

The diagram shows all possible connections. The application determines which connections are used.

Start-up

The valve body (normally open or normally closed) determines the action of the complete valve/actuator assembly.

Troubleshooting

- Check wiring for proper connections and secure attachments.
- Check for adequate power supply.

Dimensions

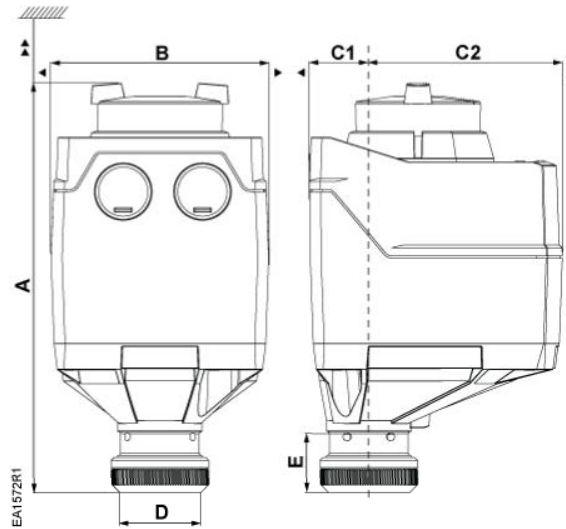

	A	B	C1	C2	D	E	▶	▶▶
Inches	5.9	3.1	0.9	2.8	1.2	0.9	4	8
mm	151	80	21.9	71.1	29.9	21.8	100	200

Figure 4. SAS61.03U Actuator Dimensions.

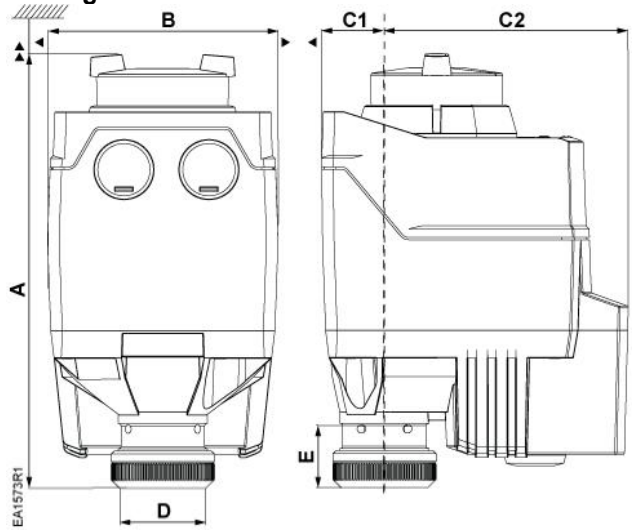

	A	B	C1	C2	D	E	▶	▶▶
Inches	5.9	3.1	0.9	3.3	1.2	0.9	4	8
mm	151	80	21.9	84.6	29.9	21.8	100	200

Figure 5. SAS61.33U Actuator Dimensions.

Information in this publication is based on current specifications. The company reserves the right to make changes in specifications and models as design improvements are introduced. Product or company names mentioned herein may be the trademarks of their respective owners.
 © 2016 Siemens Industry, Inc.