



RWF40

Hints Manual

This RWF40 Hints Manual is intended for use by OEMs which integrate the controller into their products!

This page is intentionally left blank...

Contents

1.	Introduction to hints manual.....	3
1.1.1	How to use this manual	3
1.1.2	Symbols used in this manual	3
2.	Hints.	4
2.1	Getting started with the RWF40 menu	4
2.1.1	Start with the Basic Display	4
2.1.2	User level	4
2.1.3	Parameter level	4
2.1.1	Configuration level	4
2.2	How to configure your RWF40	5
2.3	How to adjust parameters	6
2.4	How to change a setpoint (SP1, SP2, or dSP)	7
2.5	How to display the software version and units	8
2.6	Manual operation	9
2.7	Auto Tune (self setting function	10
2.8	Setting up a standard temperature application	11
2.9	Setting up a standard pressure application	12
2.10	How to unlock an RWF40 controller	13
3.	Notes.	14
3.1	Logic summary	14
3.2	List of values for User settings, Parameters, and Configurations	15

1. Introduction to hints manual

1.1.1 How to use this manual

This RWF40 hint manual is intended to *supplement* the RWF40 User Manual.

Please read the RFW40 User Manual before applying power to the controller.

1.1.2 Symbols used in this manual



These symbols represent the four buttons on the controller.
If a combination of keys is required an explanation will be given.



This symbol is used to draw your attention to a particular remark.



This symbol indicates a reference to the RWF40 user manual.

2. Hints

2.1 Getting started with the RWF40 menu

The RWF40 menu system has three Levels, beyond the **Basic Display**, the **User Level**, the **Parameter Level** and the **Configuration Level**.

⇒ [RWF40 user manual Section 6 Operation](#).

2.1.1 Start with the Basic Display

Shown at the right is the basic display.

The upper, larger, 4 digit **red** LEDs, (**180**) will be referred to as, the 'Actual value display'.

The lower, smaller, 4 digit **green** LEDs, (**180**) will be referred to as, the 'Setpoint display'.

☞ The current configuration of your specific controller will determine which levels you will be allowed to access.

C112 must be xxx0 to access the configuration level.

⚠ The C112 locking code can only be adjusted by the manufacturer.

☞ All controllers will return to the basic display automatically, if no key is pressed for 30 seconds.

The RWF40 configuration codes (C111, C112, and C113) are all four digits.

The x's used in the explanations in this manual represent a 'don't care' digit in the code, so, xxx0 could mean 1000, 2100, 5430, etc, and we are only concerned with the 'non-x' digits.

C112 code summary :

C112 code	xxx0	Locks nothing
C112 code	xxx1	Locks the Configuration Level
C112 code	xxx2	Locks the Parameter Level
C112 code	xxx3	Locks all levels and keys

2.1.2 User Level

From the basic display, you may advance to the user level, by pressing **PGM** and releasing it.

The actual value display, (**180**) shows the setpoint you are adjusting or viewing.

The setpoint display, (**SP 1**) shows the parameter you are adjusting or viewing.

You can adjust the values, within limits, for SP1, SP2, dSP, view tA, SP.E, depending on your specific configuration.

To adjust user level values, please see the "4 How to change a setpoint",

or ⇒ [RWF40 user manual Section 6.2.1](#).

RWF40 Basic display

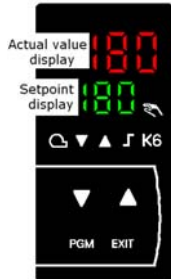

2.1.3 Parameter Level

From the user level you may advance to the parameter level, by pressing **PGM** and holding, for 3 seconds, and then releasing it.

☞ C112 must be xxx0 or xxx1, to access this level.

The actual value display, (**0**) shows the parameter's actual value.

The setpoint display, (**AL**) shows the parameter you are adjusting or viewing.

You can adjust the values for AL, Hyst, Pb.1, dt, rt, HYS.1, HYS.2, HYS.3, q, H, and P, depending on your specific configuration.

To adjust parameter values, please see "3 How to adjust parameters",

or ⇒ [RWF40 user manual Section 7](#).

2.1.4 Configuration Level

From the parameter level you may advance to the configuration level, by pressing **PGM** and holding, again for 3 seconds, and then releasing it.

☞ C112 must be xxx0 to access this level.

The actual value display, (**9030**) shows the configuration item's actual value.

The setpoint display, (**C111**) shows the configuration item you are adjusting.

You can adjust the values, within limits, for C111, C112, C113, SCL, SCH, SCL2, SCH2, SPL, SPH, OFF1, OFF2, OFF3, and dF1 depending on your specific configuration.

To adjust configuration values, please see the "2 How to configure our RWF40",

or ⇒ [RWF40 user manual Section 8](#).

Return to the Basic Display

You may exit any level, and return to the basic display at any time, in two ways.

First, to exit immediately, press **EXIT** and release it.

The second way is to simply wait 30 seconds, and the controller will automatically return to the basic display.



2. Hints

2.2 How to configure your RWF40

Shown at the right is the basic display.

The current configuration of your specific controller will determine which levels you will be allowed to access.

C112 must be xxx0 to access the configuration level.

⚠ The C112 locking code can only be adjusted by the manufacturer.

To reach the configuration level, you start from the basic display, (shown above), skip past the user level, and go first, to the parameter level, and then, finally, to the configuration level.

Press **PGM** and hold for 3 seconds, and then release it.

You are now at the parameter level.

From the parameter level you may now advance to the configuration level,

by pressing **PGM** again, holding, for 3 seconds, and then releasing it.

The actual value display, (9030) shows the current configuration value.

The setpoint display, (C111) shows the configuration item you are adjusting.

Configuration level items summary :

C111	Analog input 1 Analog input 2 Analog input 3 D2 function	sensors (14 types), standard signal none, external SP, analog SP Shift none, outdoor sensors ... none, SP chg/over, SP binary shift
C112	Limit comparator Controller type Setpoint SP1 Locking	none, input 1,2,3 ... 3-position, modulating 0-20mA, ... via buttons, with outside sensor none, configuration, parameters, buttons
C113	Unit address Unit address Decimal - Units Signal out-of-range	0-9 0-9 ° C or ° F and decimals limit comparator OFF/ON

SCL Scale Low Analog input 1
SCH Scale High Analog input 1

SCL2 Scale Low Analog input 2
SCH Scale High Analog input 2

SPL Set Point, Lower
SPH Set Point, Higher

OFF1 Actual value correction, OFFset, Analog input 1
OFF2 Actual value correction, OFFset, Analog input 2
OFF3 Actual value correction, OFFset, Analog input 3

Df1 Digital filter time constant for Analog input 1

RWF40 Basic display

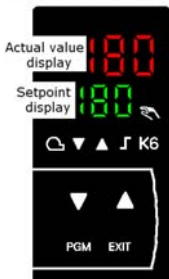

Example Re-configure (adjust) the value for C111

If no keys are pressed for 30 seconds, at anytime, the controller will automatically return to the basic display.

The current value of **C111**, (9030) is shown in the actual value display.

The current configuration item (C111) is shown in the setpoint display.

The display is steady, (not flashing) and by default, the 4th, (rightmost) digit is the one you may now adjust.

You can select the digit you want to adjust, by pressing **▼** once and releasing it.

The 3rd digit is now flashing, indicating that it is now, the adjustable digit.

(Each time you press and release **▼** you cycle, thru each digit, right-to-left and back again)

To change the value of the flashing digit, press **▲** and release it.

Each time you press **▲** and release, you cycle up thru the allowable values, and back again.

Once you have the desired value displayed and flashing, you may accept it by pressing **PGM** once and releasing it.

All four upper digits will flash once.

The controller displays the new configuration values, in 4 steady digits.

Your options at this point are:

Press **EXIT** and release, to immediately return to the basic display. or

press **PGM** and release it, to advance to C112,
press **PGM** again and release it, to advance to C113,
press **PGM** and release it, to advance to SCL,

... after the last configuration item Df1,

press **PGM** and release it, to advance to AL, (the 1st parameter),
... after the last parameter item P,

press **PGM** and release it, to advance to SP1, (the 1st user item),
... after the last user item it cycles back to the 1st user item.

Or simply wait 30 seconds and the controller will automatically return to the basic display.



2. Hints

2.3 How to adjust parameters

⇒ RWF40 user manual Section 6.3

Shown at the right is the basic display.

The current configuration of your specific controller will determine which levels you will be allowed to access.

C112 must be xxx1 or xxx0 to access the parameter level.

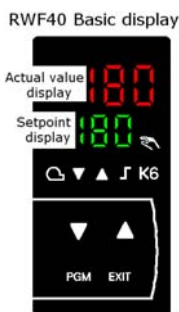

⚠ The C112 locking code can only be adjusted by the manufacturer.

From the basic display, you may skip the user level, to reach the parameter level.

Press **PGM** and hold, for 3 seconds, and release.

The actual value display, (0) shows the current parameter value.

The setpoint display, (AL) shows the parameter item you are adjusting.



Parameter level items summary:

AL	Alarm Limit value for comparator
HYS1	Switching differential, Hyst eresis 1, 2-stage burner
Pb.1	Proportional band 1
dt	derivative time
rt	Integral action time
db	* dead band , contact spacing
tt	* Actuator running time
HYS1	Switch-on threshold, Hyst eresis 1, 2-stage burner
HYS2	Switch-off threshold, Hyst eresis 2, 2-stage burner
HYS3	Switch-off threshold, Hyst eresis 3, upper
q	Response threshold
H	Heating curve slope
P	Parallel displacement

* Items are only displayed when controller is configured for a 3-position output.

Example Adjust the value for parameter AL.

If no keys are pressed for 30 seconds, at anytime, the controller will automatically return to the basic display.

The current value of AL, (0) is shown in the actual value display.

The current parameter item (AL) is shown in the setpoint display.

The display is steady, (nothing is flashing) and the value for AL can now be adjusted.



You can decrease the value by pressing **▼** and releasing it.



You can increase the value by pressing **▲** and releasing it.



You can accept the change by waiting 2 seconds.



The red LED's will blink once, and become the new value.

Or, you can advance to the Next parameter by pressing **PGM** once and releasing it.



HYS1 can be adjusted the same way you just did AL.

Your options at this point are:

Press **EXIT** and release, to immediately return to the basic display.

Press **PGM** and release it, to advance down to Pb.1, (the next parameter).

... after the last parameter item P, press **PGM** and release it, to advance down to SP1, (the 1st user item).

... after the last user item, the menu cycles back to the 1st user item.

Or simply wait 30 seconds and the controller will automatically return to the basic display.

2. Hints

2.4 How to change a setpoint

(SP1, SP2, or dSP)

⇒ RWF40 user manual Section 6.2

Shown at the right is the basic display.

The current configuration of your specific controller will determine which levels you will be allowed to access.

C112 must be xxx2, xxx1, or xxx0 to access the parameter level.

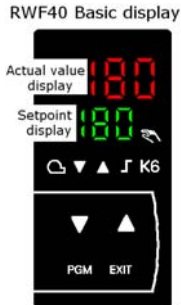

⚠ The C112 locking code can only be adjusted by the manufacturer.

From the basic display, you may skip the user level, to reach the parameter level.

Press **PGM** and hold, for 3 seconds, and release.

The actual value display, (0) shows the current parameter value.

The setpoint display, (AL) shows the parameter item you are adjusting.



Parameter level items summary:

AL	Alarm Limit value for comparator
HYS1	Switching differential, Hysteresis for limit comparator
Pb.1	Proportional band 1
dt	derivative time
rt	Integral action time
db	* dead band, contact spacing
tt	* Actuator running time
HYS1	Switch-on threshold, Hysteresis 1, 2-stage burner
HYS2	Switch-off threshold, Hysteresis 2, 2-stage burner
HYS3	Switch-off threshold, Hysteresis 3, upper
q	Response threshold
H	Heating curve slope
P	Parallel displacement

* items are only displayed when controller is configured for 3-pos output.

Example Adjust the value for parameter AL.

If no keys are pressed for 30 seconds, at anytime, the controller will automatically return to the basic display.

The current value of **AL**, (0) is shown in the actual value display.

The current parameter item (**AL**) is shown in the setpoint display.

The display is steady, (nothing is flashing) and the value for AL can now be adjusted.



You can decrease the value by pressing **▼** and releasing it.



You can increase the value by pressing **▲** and releasing it.



You can accept the change by waiting 2 seconds.



The red LED's will blink once, and become the new value.

Or, you can advance to the next parameter by pressing **PGM** once and releasing it.



HYS1 can be adjusted the same way you just did AL

Your options at this point are:

Press **EXIT** and release, to immediately return to the basic display.

Press **PGM** and release it, to advance down to Pb.1, (the next parameter).

... after the last parameter item P, press **PGM** and release it, to advance down to SP1, (the 1st user item).

... after the last user item, the menu cycles back to the 1st user item.

Or simply wait 30 seconds and the controller will automatically return to the basic display.

2. Hints

2.5 How to display the software version and units

⇒ RWF40 user manual Section 6.2 .5

Shown at the right is the basic display.

☞ The current configuration of your specific controller will determine which levels you will be allowed to access.

A C112 of xxx3 will prevent use of the keys.

RWF40 Basic display

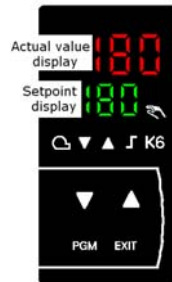

⚠ **The C112 locking code can only be adjusted by the manufacturer.**

You can display the software version, and units, of your controller, at any time, by pressing the **PGM + ▲** at the same time, and holding them...

You will see one, of the three displays shown below.



The software version of your controller, (Version 102 in this example.) is shown in the actual value display.

The current units configuration (°C, °F, or %) is shown in the setpoint display.

☞ The display will return, to the where it was, *if you release the keys at the same time*, if not, you will return back to the basic display.

Configure Codes \ Units summary:

°C will be displayed if your controller is configured with:

C111	0xxx .. dxxx	Analog input 1	Sensor (Pt100, Ni100, ..)
C113	xx0x	No decimals	°C
C113	xx1x	One decimal	°C

°F will be displayed if your controller is configured with

C111	0xxx .. dxxx	Analog input 1	Sensor (Pt100, Ni100, ..)
C113	xx2x	No decimals	°F
C113	xx3x	One decimal	°F

% w will be displayed if your controller is configured with:

C111	Exxx .. Hxxx	Analog input 1	Standard input (4-20mA, ..)
C113	xx0x .. xx3x		Doesn't matter

2.6 Manual operation

⇒ RWF40 user manual Section 6.2 .2 and 6.2.3.

Shown at the right is the basic display.

☞ The current configuration of your specific controller will determine which levels you will be allowed to access.

A C112 of xxx3 will prevent use of the keys.

RWF40 Basic display

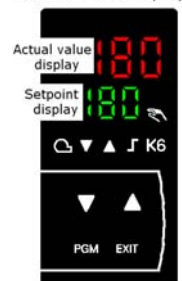

⚠ **The C112 locking code can only be adjusted by the manufacturer.**

☞ Manual operation can *only* be performed when the thermostat function is active and burner is released to modulation.

The **green** burner LED must be on, relay 1 is energized, and the contact, Q13 N.O. - Q14 Com, is closed.

If at any time the burner LED turns off, the controller will exit the manual operation function.



2. Hints

2.6 Manual operation continued...

Modulating burner, 3-Position output

Press **EXIT** and hold for 5 seconds, and release.

The red LED above the manual icon turns on to indicate that the controller is now in the manual mode.

Relay 2 and relay 3 will hold their current state, (energized or de-energized) that they were in until another key is pressed.



When the **▼** is **pressed**:

- Relay 3 is energized
- Decrease icon turns on
- N.O. contact Q-Y2 closes, to drive the modulating device down, which decreases the firing rate of the burner.



When the **▼** is **released**:

- Relay 3 is de-energized
- Decrease icon turns off
- N.O. contact Q-Y2 opens, to hold the modulating device where it is, which holds the firing rate of the burner.



When the **▲** is **pressed**:

- Relay 2 is energized
- Increase icon turns on
- N.O. contact Q-Y1 closes, to drive the modulating device up, which increases the firing rate of the burner.



When the **▲** is **released**:

- Relay 2 is de-energized
- Increase icon turns off
- N.O. contact Q-Y1 opens, to hold the modulating device where it is, which holds the firing rate of the burner.

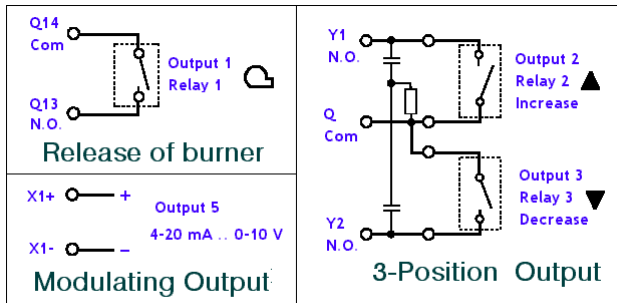

Figure 1 Connection diagrams

Modulating burner, Modulating output

Press **EXIT** and hold for 5 seconds, and release.

The red LED above the manual icon turns on to indicate that the controller is now in the manual mode.

Relay 2 and relay 3 will hold their current state, (energized or de-energized) that they were in until another key is pressed.



By design, the 0 output starts driving the modulating device to low fire, but if you promptly press the **▲** after the red LED above the hand icon turns on, you can prevent the from going all the way.

When the **▼** is **pressed**,

- the output value starts increasing,
- and the output, to terminals X1+ and X1- starts increasing, the same amount, and increases the firing rate of the burner.



When the **▼** is **released**,

- output value, stops increasing,
- and the output, to terminals X1+ and X1- also stops increasing, and holds the current firing rate of the burner.



When the **▲** is **pressed**,

- the output value starts decreasing,
- and the output, to terminals X1+ and X1- starts decreasing, the same amount, and decreases the firing rate of the burner.



When the **▲** is **released**,

- output value, stops decreasing,
- and the output, to terminals X1+ and X1- also stops decreasing, and holds the current firing rate of the burner.



To exit manual operation

Press **EXIT** for 5 seconds, and release.

The red LED above the hand symbol turns off, and the controller returns to the automatic mode.

On Modulating burners, with modulating output, the output to terminals X1 and X2, also returns to automatic operation.

On Modulating burners, with 3-position output, the output to relay 2 and relay 3, also returns to automatic operation.



2. Hints

2.7 Auto-tune (self-setting function)

⇒ RWF40 user manual section 6.2.4 and 9.1

The RWF40 User manual refers to a 'self-setting-function' that for the purposes of this manual will be referred to as 'Auto-tune'.

Technical Explanation

Auto-tune is a self-setting software function, that is integrated into the RWF40 controller, and can be repeated as often as desired.

Auto-tune tests the reaction, in the modulating mode of operation, of the process-control loop, to steps in the actuator position, according to a special procedure.

The data, during the forced oscillations, is then recorded, and used to calculate new values, that are optimized for your specific controlled system.

Auto-tune items summary:

Items at the user level that will affect **Auto tune**

- SP 1** Set Point 1
- HYS1** Switch-on threshold, **HYS**teresis 1
- HYS3** Switch-off threshold, **HYS**teresis 3,

Items at the Parameter level that **Auto-tune** will adjust

- Pb.1** Proportional **b**and 1 (Factory setting 10)
- dt** derivative **t**ime (Factory setting 80)
- rt** Integral action **t**ime (Factory setting 350)

Item at the configuration level that **Auto-tune** will adjust

- df1** Time constant for **d**igital **F**ilter, analog 1

Values for **Pb.1**, **dt**, **rt** and **df1**, can always be changed.

Auto-tune uses **two different methods** to force oscillations, and will **automatically select and use**, a method, based on, at the start of **Auto-tune**, what the **difference** is, between the **setpoint (w)**, and the **process value**.

When **Auto-tune** is started with a **large difference**, (typically *before* the process-control loop has stabilized) **Auto-tune** performs a forced oscillation around a **switching level**.

When **Auto-tune** is started with a **small difference**, (typically *after* the process-control loop has stabilized) **Auto-tune** performs a forced oscillation, around the **setpoint (w)**.

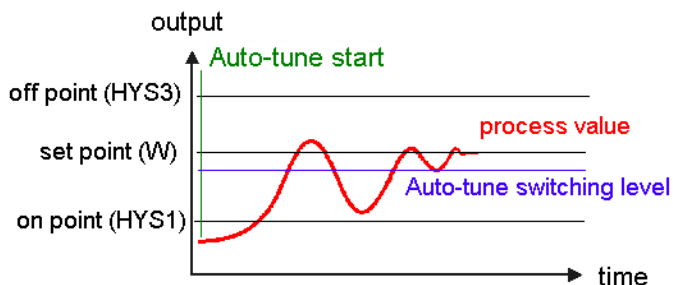

If for any reason the controller exceeds the switch off threshold (HYS3) **Auto-tune** will be cancelled.

Conditions

The controller must be :

- in the modulating output mode (D1 is open and the step icon is off)
- burner is released (green LED above is on, relay 1, is activated, contact between terminals Q14 and Q13 is closed)
- controller is not in manual mode (red LED above is off)

Procedure

Start **Auto-tune** by pressing **PGM**+ and release.

The current temperature value, (175) is shown in the actual value display.

The current function item (**tunE**) is flashing in the setpoint display.

You can cancel **Auto-tune** while it is flashing pressing and releasing.



When **tunE** stops flashing on it's own **Auto-tune** is complete.

You can save the new values for **Pb.1**, **dt**, **rt** and **df1**, by pressing , and holding for at least 2 seconds.



Possible results, and their correction. A favorable value for dt is rt/4.

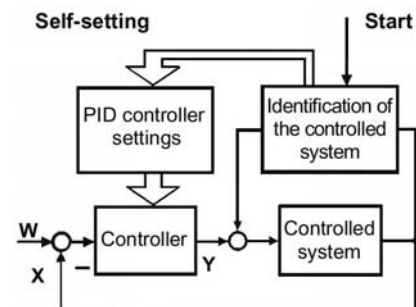
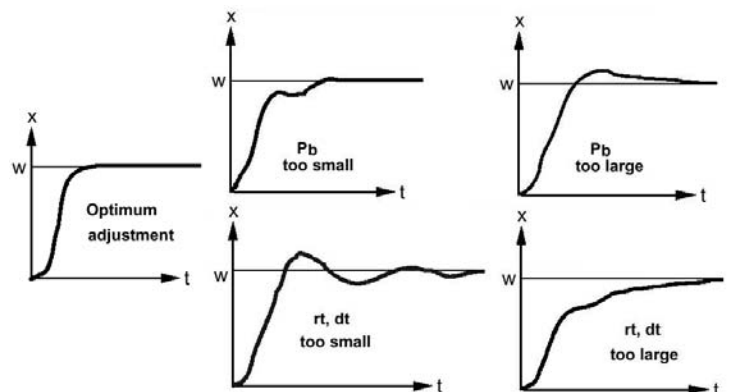

Block diagram of Auto-tune.

2. Hints

2.8 Setting up a standard temperature application

Using a 1000 ohm Ni RTD,
L & S # 556-541 -13 °F to +203 °F

Configure

If no keys are pressed for 20 seconds, the controller will exit this mode, and return to the basic display.

See Hint section 2.2, 'How to configuration your RWF40'.

(From the basic display, or user level,

press **PGM** and hold, for 3 seconds,
and then release, and again,

press **PGM** and hold, for 3 seconds,
and then release)



The actual value display, (9030)
shows the current configuration item *value*.

The setpoint display, (C111)
shows the configuration *item* you are adjusting.

The display is steady, (not flashing) and by default,
the 4th, (rightmost) digit may now be adjusted.

You can select which digit you wish to adjust, by
pressing **▼** once and releasing it. The 3rd digit is now
flashing, indicating that it is now, the adjustable digit.



Cycle thru each digit of C111 and configure as charted
below, then accept by pressing **PGM** and releasing.

All four upper digits will flash once, and the new
configuration value, is displayed in 4 steady digits.

Press **PGM** and release, to configure C112, C113, ... thru Df1.

Configuration level values:

Item	Description	Value	* Sec
C111		9000	
	Analog input 1	9	Landis & Staefa Ni 1000 8.1
	Analog input 2	0	None 8.1
	Analog input 3	0	None 8.1
	D2 function	0	None 8.1
C112		8200	8.1
	Limit comparator	8	input 1 8.1
	Controller type	2	modulating 4-20mA 8.1
	Setpoint SP1	0	via buttons 8.2
	Locking	0	None 8.2
C113		0220	
	Unit address	02	Modbus address 8.2
	Decimal - Units	2	(%) no decimals 8.2
	Out-of-range Signal	0	limit comparator OFF 8.2
SCL	SCale Low	0	Analog input 1 8.3.1
SCH	SCale High	100	Analog input 1 8.3.2
SCL2	SCale Low	0	Analog input 2 8.3.3
SCH2	SCale High	100	Analog input 2 8.3.4
SPL	SetPoint Low	160	limits low setpoint to 160 °F 8.3.5
SPH	SetPoint High	205	limits high setpoint to 205 °F 8.3.6
OFF1	Actual value correction	0	Analog input 1 8.3.7
OFF2	Actual value correction	0	Analog input 2 8.3.8
OFF2	Actual value correction	0	Analog input 3 8.3.9
Df1	Digital filter time constant	0	Analog input 1 8.3.10

Set parameters

See Hint section 2.3, 'How to adjust parameters'

The actual value display, (0)
shows the current parameter *value*.

The setpoint display, (AL)
shows the parameter *item* you are adjusting.

Increase **▲** or decrease **▼** the value,
accept it by waiting 2 seconds.

Once it flashes, proceed to the next parameter
(HYSt) by pressing **PGM** and releasing.

Adjust all of the parameters as shown below.



Parameter level values:

Value	Item	Description	* Sec
160	AL	Limit value for comparator	8.2
5	HYSt	Switching differential for limit comparator	8.2
10	Pb.1	SPE setpoint external	9.2
80	dt	Derivative time	9.2
350	rt	Integral action time	9.2
-5	HYS1	Burner-on 5 °F below setpoint	5.5.1
3	HYS2	Burner-off, 2-stage	5.2.3
5	HYS3	Burner-off 5 °F above setpoint	5.5.1
0	q	Response threshold	5.6
1	H	Heating curve slope	5.5.1
0	P	Parallel displacement	5.5

Set user level values

See Hint section 3.4, 'How to change a setpoint'.

You may enter the user level, directly from
the basic display.

Press **PGM** and release.

The actual value display, (180)
shows the current user level item *value*.

The setpoint display, (SP 1)
shows the user level *item* you are adjusting.



Increase **▲** or decrease **▼** the value, accept it by
waiting 2 seconds. Once it flashes,
press **PGM** and release.

Adjust SP1 as shown below.

User level values:

Value	Item	Description	* Sec
180	SP 1	Set point 1	5.5.1

Setup is complete!

* Sec Refers to the RWF40 user manual section.

2. Hints

2.9 Setting up a standard pressure application

Using a QBE sensor,
Siemens part # QBE620-P10 [P10 is 150PSI]

Configure

If no keys are pressed for 20 seconds, the controller will exit this mode, and return to the basic display.

See Hint section 2.2, 'How to configuration your RWF40'.

(From the basic display, or user level,

press **PGM** and hold, for 3 seconds,
and then release, and again,
press **PGM** and hold, for 3 seconds,
and then release)

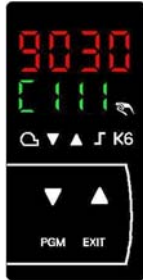

The actual value display, (9030)
shows the current configuration item value.

The setpoint display, (C111)
shows the configuration item you are adjusting.

The display is steady, (not flashing) and by default,
the 4th, (rightmost) digit may now be adjusted.

You can select which digit you wish to adjust, by
pressing **▼** once and releasing it. The 3rd digit is now
flashing, indicating that it is now, the adjustable digit.

Cycle thru each digit of C111 and configure as charted
below, then accept by pressing **PGM** and releasing.



All four upper digits will flash once, and the new
configuration value, is displayed in 4 steady digits.

Press **PGM** and release, to configure C112, C113, ... thru Df1.

Configuration level values:

Item	Description	Value	* Sec
C111		G000	
	Analog input 1	9	Std Signal 0-1VDC 8.1
	Analog input 2	0	none 8.1
	Analog input 3	0	none 8.1
	D2 function	0	none 8.1
C112		8200	8.1
	Limit comparator	8	input 1 8.1
	Controller type	2	modulating 4-20mA 8.1
	Setpoint SP1	0	via buttons 8.2
	Locking	0	none 8.2
C113		0220	
	Unit address	02	Modbus address 8.2
	Decimal - Units	2	(%) no decimals 8.2
	Out-of-range Signal	0	limit comparator OFF 8.2
SCL	SCale Low	0	Analog input 1 8.3.1
SCH	SCale High	150	Analog input 1 8.3.2
SCL2	SCale Low	0	Analog input 2 8.3.3
SCH2	SCale High	100	Analog input 2 8.3.4
SPL	SetPoint Low	150	limits low setpoint to 160 °F 8.3.5
SPH	SetPoint High	15	limits high setpoint to 205 °F 8.3.6
OFF1	Actual value correction	0	Analog input 1 8.3.7
OFF2	Actual value correction	0	Analog input 2 8.3.8
OFF2	Actual value correction	0	Analog input 3 8.3.9
Df1	Digital filter time constant	0	Analog input 1 8.3.10

Set parameters

See Hint section 2.3, 'How to adjust parameters'

The actual value display, (0)
shows the current parameter value.

The setpoint display, (AL)
shows the parameter item you are adjusting.

Increase **▲** or decrease **▼** the value,
accept it by waiting 2 seconds.

Once it flashes, proceed to the next parameter
(HYS^t) by pressing **PGM** and releasing.

Adjust all of the parameters as shown below.



Parameter level values:

Value	Item	Description	* Sec
160	AL	Limit value for comparator	8.2
5	HYS ^t	Switching differential for limit comparator	8.2
10	Pb.1	SPE setpoint external	9.2
80	dt	Derivative time	9.2
350	rt	Integral action time	9.2
-5	HYS1	Burner-on 5 °F below setpoint	5.5.1
3	HYS2	Burner-off, 2-stage	5.2.3
5	HYS3	Burner-off 5 °F above setpoint	5.5.1
0	q	Response threshold	5.6
1	H	Heating curve slope	5.5.1
0	P	Parallel displacement	5.5

Set user level values

See Hint section 3.4, 'How to change a setpoint'.

You may enter the user level, directly from
the basic display.

Press **PGM** and release.
The actual value display, (180)
shows the current user level item value.

The setpoint display, (SP 1)
shows the user level item you are adjusting.



Increase **▲** or decrease **▼** the value, accept it by
waiting 2 seconds. Once it flashes,
press **PGM** and release.

Adjust SP1 as shown below.

User level values:

Value	Item	Description	* Sec
100	SP 1	Set point 1	5.5.1

Setup is complete!

* Sec Refers to the RWF40 user manual section.

3. Notes

3.1 Logic summary K6 AL function Terminals Q64 & Q65.. , Ik1 thru Ik8

Window Function
(setpoint)

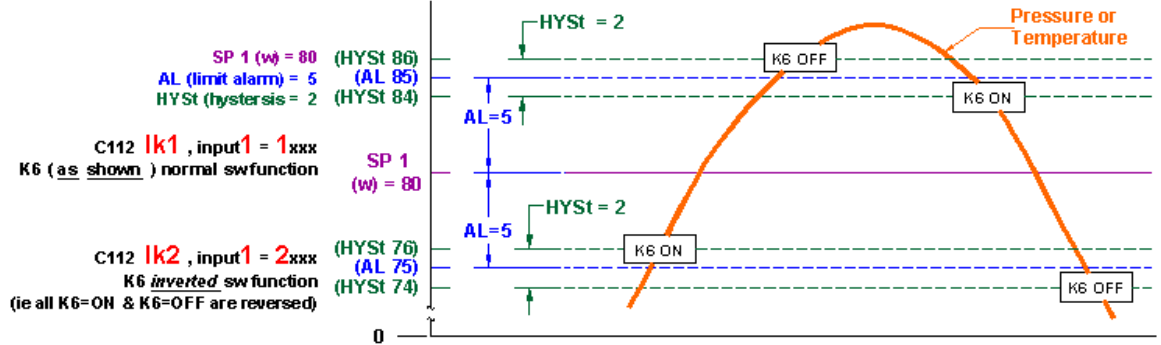

Lower Limit
(setpoint)

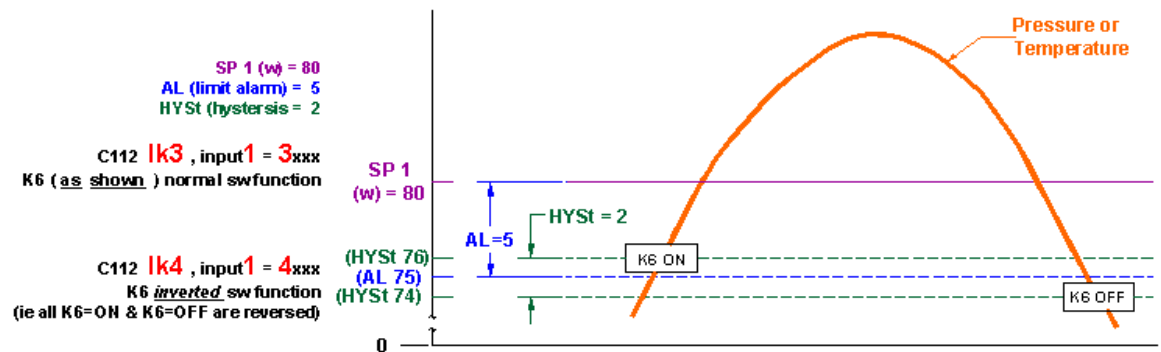

Upper Limit
(setpoint)

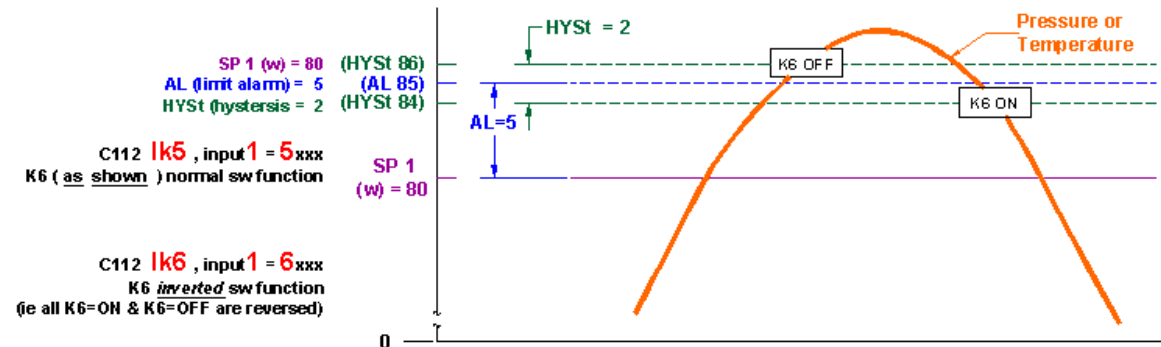

Absolute function
(NOT related to setpoint)

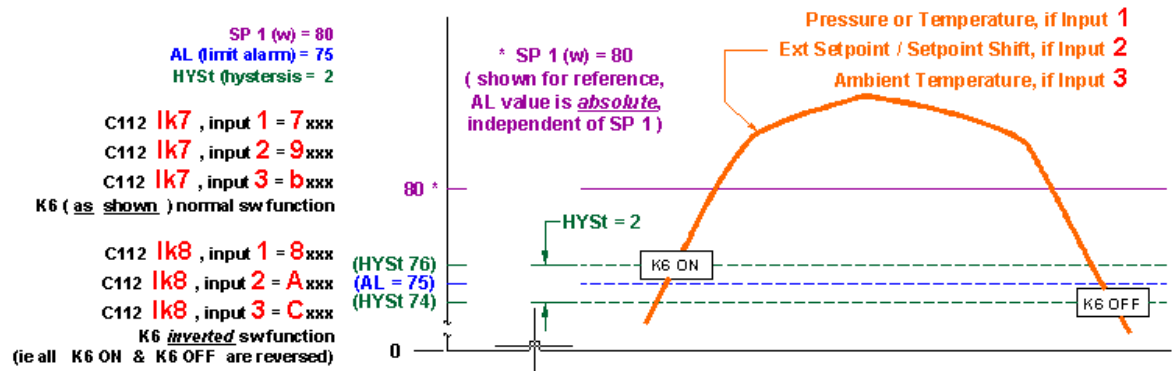

3. Notes

3.2 Your record of values

RWF40 Man. Ref.	Setpoint Display	Your Setting	Configuration level items (Sec 6.4)	Range	Factory
Sec 8.1	C111		Analog input 1, 2 and 3; D2 setpoint changeover / shift	N / A	9030
Sec 8.1 / 8.2	C112		Limit comparator; controller type; setpoint 1; locking	N / A	0010
Sec 8.1	C113		Unit address; decimal place / unit, signal for out-of-range	N / A	0110

Sec 8.3.1	SCL		SCale Low, analog input 1, measured value range	-1999 to +9999	0
Sec 8.3.2	SCH		SCale High, analog input 1, measured value range	-1999 to +9999	100
Sec 8.3.3	SCL2		SCale Low, analog input 2, measured value range	-1999 to +9999	0
Sec 8.3.4	SCH2		SCale High, analog input 2, measured value range	-1999 to +9999	100

Sec 8.3.5	SPL		Set Point Low limit	-1999 to +9999	0
Sec 8.3.6	SPH		Set Point High limit	-1999 to +9999	100

Sec 8.3.7	OFF1		OFFset analog input 1, Actual value correction	-1999 to +9999	0
Sec 8.3.8	OFF2		OFFset analog input 2, Actual value correction	-1999 to +9999	0
Sec 8.3.9	OFF3		OFFset analog input 3, Actual value correction	-1999 to +9999	0

Sec 8.3.10	dF1		digital Filter, analog input 1, 2 nd order, in seconds	0 to 100	1
------------	------------	--	---	----------	---

Setpoint Display	Your Setting	Configuration level items, Modbus option (only RWF40.0X2B97) (Sec 6.4)	Range	Factory	
Sec 8.3.11	dF3		Filter time constant, digital Filter, analog input 3 weather-dependent setpoint shift	0 to 1440	1278
Sec 8.3.12	oLLo		Working range, Limit Lower	1999 to +9999	-1999
Sec 8.3.13	oLHi		Working range, Limit High	1999 to +9999	9999
Sec 8.3.14	Dtt		Bus watchDog timer (in seconds)	0 to 7200	30

Setpoint Display	Your Setting	Parameter level items (Sec 6.3)	Range	Factory	
Sec 7 / 8.2	AL		Alarm value for K6 Limit comparator (alarm programmable relay)	-1999 to +9999	0
Sec 7 / 8.2	HYSst		Hysteresis, (switching differential) for K6 limit comparator	0 to 999.9	1
Sec 7 / 8.2	Pb.1		Proportional band 1 (affects P-response of controller)	0.1 to 999.9	10
Sec 7 / 8.2	dt		derivative time (in seconds) (affects D-response of controller)	0 to 9999	80
Sec 7 / 8.2	rt		Integral action time (in seconds) , (affects I-response of controller)	0 to 9999	350
Sec 7 / 8.2	db *		dead band, contact spacing, * visible when C112 is xxx0, 3-pos modulating	0 to 999.9	1
Sec 7 / 8.2	tt *		Actuator running time (in seconds) , * visible when C112 is xxx0, 3-pos modulating	10 to 3000	15
Sec 7 / 5.11	HYS1		Switch-on threshold, HYSteresis 1, 2-stage burner	0 to -199.9	-5
Sec 7 / 5.2	HYS2		Switch-off threshold, HYSteresis 2, 2-stage burner	0 to HYS3	3
Sec 7 / 5.2	HYS3		Switch-off threshold, HYSteresis 3, upper	0 to 999.9	5
Sec 7 / 5.6	q		Response threshold (Q)	0 to 999.9	0
Sec 7 / 5.51	H		Heating curve slope	0 to 4	1
Sec 7 / 5.5	P		Parallel displacement (weather dependent setpoint shift)	-90 to +90	0

Setpoint Display	Your Setting	User level items (Sec 6.2.1)	Range	Factory	
Sec 6.2.1	SP1		Set Point 1	SPL to SPH	0
Sec 6.2.1	SP2		Set Point 2, digital input 2, D2=0	SPL to SPH	0
Sec 6.2.1	dSP		digital Set Point shift, digital input 2, D2=1	SPL to SPH	0
Sec 11.1.3	tA		temperature, Ambient (outside) analog input 3, visible when C111 is xx1x, xx2x, xx3x		--
Sec 11.1.2	SP.E		Set Point External, predefinition, analog input 2, visible when C111 is xx1x, xx2x, xx3x	SPL to SPH	--

Siemens Building Technologies
Landis & Staefa Produktion GmbH

Berliner Ring 23

D - 76347 Rastatt

Tel. 0049 - 7222 - 598 - 0

Fax. 0049 - 7222 - 598 269

<http://www.landisstaefa.com>

© 2002 Siemens Building Technologies
Subject to change!