



QGO21.000D17



QGO21.000D27

## Oxygen Sensor QGO21...

### Basic Documentation

The QGO21 and this Basic Documentation are intended for use by OEMs which integrate the oxygen sensor in their products!



**Note!**

The QGO21 may only be operated with the following system components:

Type	from software version
AZL52...	04.90
LMV52.2...	05.00
LMV52.4...	10.10
PLL52...	01.50

QGO21 must be selected as the O2 sensor in the O2 module.

# Supplementary documentation

Basic Documentation LMV5..... P7550

User Manual LMV52 ..... A7552

Mounting Instruction QGO21. .... M7845 (4 319 0866 0)

# Contents

Supplementary documentation.....	2
1 Safety notes.....	4
1.1 Warning notes .....	4
1.2 Engineering notes.....	6
1.3 Installation and mounting notes.....	6
1.4 Electrical connection.....	7
1.5 Commissioning notes .....	8
1.6 Standards and certificates .....	10
1.7 Service notes.....	10
1.8 Disposal notes .....	10
2 Overview.....	11
3 Assortment connections .....	12
4 Technical data .....	13
5 Description of functions .....	14
5.1 Functioning principle of the measuring cell .....	14
5.2 Impact of the cell's temperature .....	16
5.3 Impact of the reference gas.....	17
5.4 Switching on and switching off .....	17
5.5 Aging .....	17
6 Mechanical design of the sensor .....	18
7 Mounting and connecting the sensor.....	19
7.1 Mounting.....	19
7.2 Connection .....	20
8 Connection diagram .....	21
9 Dimensions.....	22
10 Comparison table .....	24
11 List of figures .....	25
12 Index.....	26

# 1 Safety notes

## 1.1 Warning notes



To avoid injury to persons, damage to property or the environment, the following warning notes must be observed!

**It is not permitted to open the sensor incorrectly, interfere with or make changes to the sensor!**

- All activities (mounting, installation, service, etc.) must be performed by qualified staff
- Before making any wiring changes in the connection area, completely isolate the plant from mains supply (all-polar disconnection). Ensure that the plant cannot be inadvertently switched on again and that it is indeed dead. If not observed, there is a risk of electric shock hazard
- Ensure protection against electric shock hazard by providing adequate protection for the connection terminals
- During operation, the sensor's connecting head must be kept closed; all 3 screws must be securely tightened
- Each time work has been carried out (mounting, installation, service work, etc.); check to ensure that wiring of connected lines is in an orderly state and make the safety checks as described in *Commissioning notes*. Keep cables away from extremely hot plant equipment or sensor parts
- During burner operation, QGO21 must be kept on operating temperature via associated control unit (LMV52 with PLL52)
- Always keep the sinter filter free from dirt, this extended the response time of the sensor
- The maintenance timer of LMV52 must be used to ensure that the maintenance interval is complied with (see LMV52 User Documentation A7552)
- All setting instructions of the LMV52... must be observed (see User Documentation A7552, chapter O2 control). In particular, we wish to draw your attention to the manipulated variable limitation that is described there.
- The environment must be free from chemicals such as vapors from solvents
- Before cleaning the sinter filter, allow the QGO21 to cool down for at least 1 hour. When using compressed air for cooling (only after the sensor has completely cooled down), pressures up to 0.5 bar are permitted. If this is not observed, the sensor can be damaged in a way that inadmissibly high CO levels in the flue gases can occur



### Caution - risk of explosion!

**Check that the sintered filter is seated correctly, has been screwed tightly in place, and inspect the sensor for damage. If sensors are damaged or not tightly fitted, or if sintered filters are not present, this may lead to the loss of the flame arrester.**



### Warning!

**The QGO21 must be maintained regularly.**

**The OEM and the heating engineer are obliged to:**

- **set a maintenance interval suitable for the system and**
- **to carry out the maintenance outlined in the QGO21 Basic Documentation (P7845), chapter *Maintenance instructions*.**

- Fall or shock can adversely affect the safety functions and lead to dangerous conditions. Such sensors must not be put into operation, even if the measuring cell does not exhibit any damage
- Ensure that air cannot enter the space between burner and measuring parts. In particular, the mounting flange must be completely gas-tight

- The sensor must always be installed so that the connecting part (head to the flange) remains free and that unimpeded air exchange through the reference air slots is guaranteed. Otherwise, there is a risk of false measurements, which can lead to dangerous conditions
- Ensure that the hot QGO21 does not get into contact with explosive or inflammable gases
- QGO21 may only be used in conjunction with AGO21



**Caution - risk of burns!**

- There is a risk of burning since the measuring cell works at an operating temperature of 700 °C and other accessible parts can get very hot too (>60 °C)
- To prevent injury caused by the hot sensor tube, remove the QGO21 from the AGO21 mounting flange only after the equipment has cooled down

## 1.2 Engineering notes

---

- If the burner is shut down for no more than 1 or 2 days, do not switch off the QGO21 and the associated control unit (LMV52 with PLL52)
- To ensure a good response, always use the QGO21 together with the AGO21
- Flue gas temperatures at the QGO21 must not exceed 300 °C, since higher temperatures can destroy the sensor
- QGO21 may only be used with the approved fuels, as other fuels can destroy the sensor with their aggressive components (see Technical data)
- Heavy metals in the fuel, such as lead, cadmium etc., destroy the sensor element and therefore may not be contained
- Silicones and silicone vapors in the flue gas can damage the sensor element and therefore may not be contained
- Following element in the flue gas reduces the life cycle of the sensor elements and should not be contained:  
Silicon, sulfur, phosphor, boric, bismuth, copper and halogens (F, Cl, Br, I) and their compounds (e.g. FCKW)
- NO<sub>x</sub>, SO<sub>x</sub> and reducing atmospheres, such as CO by an incomplete burning, impair the life time of the sensor element depending on the concentration and the influence time

## 1.3 Installation and mounting notes

---

- Ensure that the relevant national safety regulations are complied with
- The flue gas flow passing the measuring point should be homogeneous. When mounted too close to air dampers or pipe bends, faulty measurements can occur
- The exchange of fresh air in the connection area of the sensor with the reference air slots must be ensured and may never be covered up (by insulation or similar)
- The sensor should not be exposed to aggressive gases (NO<sub>x</sub>, etc.). This applies to both the gas and air side since aggressive gases can drastically shorten the sensor's life
- Disturbances can distort the measurements (this can lead to dangerous conditions in connection with O<sub>2</sub> trim control):
  - If flueways are not tight, false air can join the flue gases. In that case, the oxygen content acquired by the sensor is above the real content
  - When flue gas velocities are low, the sensor will respond more slowly since the flue gases need more time to pass the measuring cell
  - The further the sensor is mounted from the flame, the longer the dead time
- For expected ambient temperatures between 50 °C and 70 °C, the connecting wires between the terminals Q4 or Q5 and the Pg screw connection must also be insulated with the high-temperature bushings provided



### Note

For detailed information on mounting, refer to Mounting Instructions M7845 (74 319 0866 0).

## 1.4 Electrical connection

---

It is important to achieve practically disturbance- and loss-free signal transmission:

- Never run the sensor cable together with other cables; use a separate cable
- Observe the permissible length of the sensor cables and the relevant specification (see Technical data)

## 1.5 Commissioning notes

---

- To prevent the collection of condensate inside the QGO21, do not put the burner into operation before the sensor's heating up phase is completed

During the sensor's heating up phase, temperature differences between the inner and outer electrode generate thermo-electric voltages which, in that phase, falsify the acquired oxygen value.

When commissioning the control system, the heating up times must therefore be observed.

It is also recommended to keep the sensor activated during short burner off periods (2 days).

Prior to commissioning, make the following mounting final checks:

- Check to ensure that the sensor is correctly fitted to the mounting flange
- Ensure that the signal and power supply lines are correctly connected

Electronic circuit

- Activate the electronic circuit (LMV52, PLL52)
- Wait until the sensor has reached its normal operating temperature, the residual oxygen content is displayed on the associated control unit (LMV52 with PLL52) and has stabilized. For more details, refer to the Basic Documentation of the associated control unit (LMV52 with PLL52)

After the final mounting check, a first functional check can be made:

## Functional check

Before commissioning for the first time or after replacing the QGO21, the QGO21 must be checked for temporary O<sub>2</sub> measured value distortion.

The QGO21 must measure the O<sub>2</sub> value with sufficient accuracy before an O<sub>2</sub> setpoint curve is set.

Humidity deposits in the QGO21 can lead to O<sub>2</sub> measured value distortion. In the first few hours after the QGO21 is switched on, the O<sub>2</sub> measured values may be distorted, resulting in the values being too low.

Example: 4.1% O<sub>2</sub> content may be shown instead of 5%.

The following measures must be implemented to prevent distorted O<sub>2</sub> measurements:

1. Operate the QGO21 continuously on the system under voltage for at least 8 hours with the sensor heating switched on.
2. Then operate the burner in pre-ventilation phase for 15 minutes and observe the O<sub>2</sub> measured value until a value between 19.5% and 21% is measured. If this has still not happened after 15 minutes in pre-ventilation phase, there is a temporary O<sub>2</sub> measured value distortion. The O<sub>2</sub> setpoint curve must not be set.  
New QGO21 devices must be pre-heated for up to 12 hours longer before no temporary O<sub>2</sub> measured value distortion occurs and a relevant O<sub>2</sub> value is achieved in the pre-ventilation phase.  
Older QGO21 devices must be replaced or cleaned if the relevant O<sub>2</sub> value is not achieved in the pre-ventilation phase within the specified time frame.



### Note!

Important point to remember for urea injection and other sources of humidity: Humidity reduces the O<sub>2</sub> value in the flue gas.

Example: If an O<sub>2</sub> setpoint curve is set when a humidity source is active, the O<sub>2</sub> control can reduce the air more than desired during normal operation if the humidity source stops working at a later stage. Sufficient oxygen reserves must be taken into account in the O<sub>2</sub> setpoint curve for this eventuality.

It is also possible to make a functional check of the QGO21 based on a comparative measurement.

Comparative measurement means that, during burner operation, the actual oxygen value is measured with a flue gas analyzer and will then be compared with the value acquired by the QGO21.



### Note

Flue gas analyzers measure «dry», the QGO21 measures *wet*.

The conversion is made with the help of the conversion table contained in the Addendum to this Basic Documentation.

## 1.6 Standards and certificates

---



Note!  
Only in connection with LMV52 with PLL52!



EAC Conformity mark (Eurasian Conformity mark)



ISO 9001:2008  
ISO 14001:2004  
OHSAS 18001:2007

## 1.7 Service notes

---

After no more than 3 months of operation following commissioning, check the sensor's internal resistance. If it exceeds 30  $\Omega$ , shorten the service interval to 3 months. Sensors having an internal resistance of >100  $\Omega$  should no longer be used for control tasks since their response is too slow. For this reason, to ensure proper functioning, sensors with a resistance of >100  $\Omega$  should be replaced.

- Make certain that the sensor's sinter filter is always kept free from dirt
- Regularly inspect the sintered filter of the QGO21 for contamination. The inspection intervals and the value for the LMV52 maintenance timer are based on the level of contamination observed.

The recommended value for the first maintenance timer setting is 3 months.

The final value can then be set at a later stage based on the level of contamination observed.

The following maintenance work must be carried out if contamination is identified:

- A cooling time of at least 2 hours must be observed.
- Clean the sintered filter using a brass wire brush or compressed air or replace the sintered filter (sintered filter for service AGO742870012).
- The sintered filter must not become damaged during cleaning. If the sintered filter becomes damaged or cannot be cleaned, it must be replaced. The replaced sintered filter must not be used again.
- The grid of the inlet and outlet orifices must not be damaged at cleaning. If grid is damaged or the sensor can not be cleaned completely, the sensor must be replaced. The replaced sensor must not be used again
- Check flange gasket on each service visit and replace if necessary
- After cleaning and heating up, check oxygen measurement in the burner's entire working range
- The QGO21 must not come into contact with water.
- The maintenance timer in the LMV52 must be reset once the maintenance work is complete

## 1.8 Disposal notes

---



The oxygen sensor contains electrical and electronic components and must not be disposed of together with household waste.

Local and currently valid legislation must be observed.

## 2 Overview

The QGO21 is an oxygen sensor that is used to acquire the residual oxygen content of flue gases in heat generating plants that heavy oil. The oxygen sensor works as a diffusion sensor with a sintered filter for the flue gas inlet. In connection with the control unit (LMV52 with PLL52), QGO21 monitors and controls the combustion process. For mounting the QGO21, AGO21 mounting flange are available. They can be welded directly into the chimney.

The QGO21 in connection with the AGO21 is suited for use on all types of heat generating plant which burn heavy oil with flue gas temperatures up to 300 °C at the test point.

When used in connection with burner controls type LMV52... for residual oxygen control, the efficiency of combustion will be improved and oxygen emissions minimized.

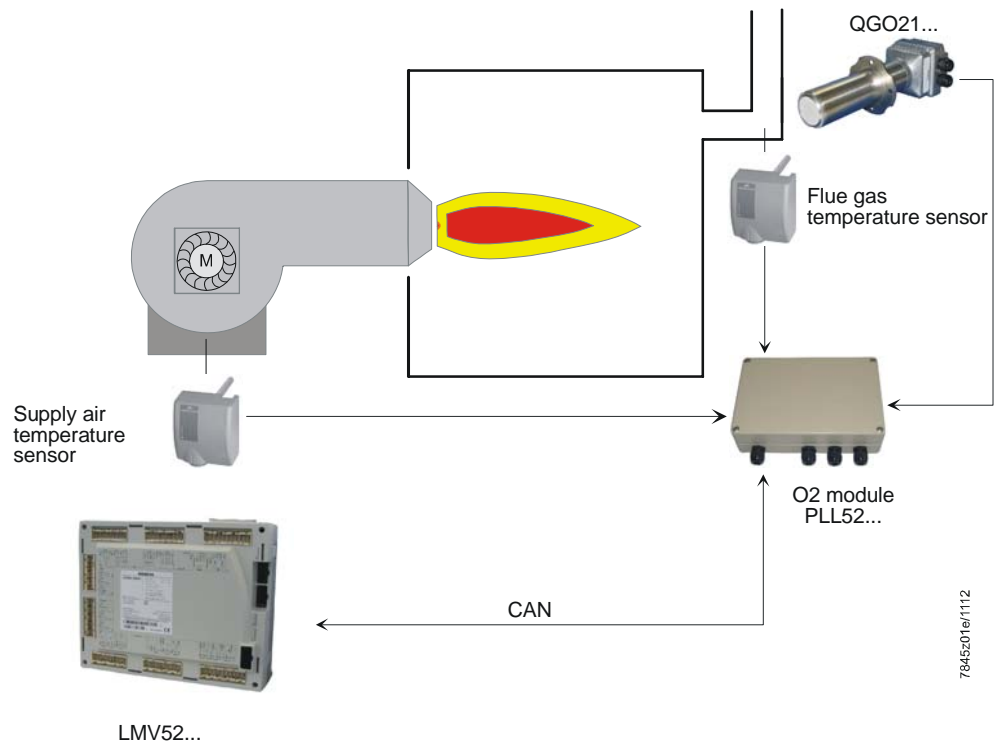

Figure 1: Example General overview

**QGO21** consists of

- a stainless steel sensor tube with mounting flange
- retaining ring screwed on the front with sintered filter
- a connecting head made from die-cast aluminum

**Sensor tube** surrounds and protects

- the measuring cell,
- the cell heating

The **connecting head** contains a circuit board with terminals for electrical connections. The cables are fed in via replaceable glands with Pg9 screw connection. These glands can be left on the cable, making installation and servicing easier.

The **mounting flange** AGO21 is an accessory for the QGO21.

- which is welded on to the point of measurement and
- acts as a mounting flange

### 3 Assortment connections

---

**Oxygen sensor**, complete with flange gasket

- AC 230 V

**QGO21.000D27**

- AC 120 V

**QGO21.000D17**

**Control unit** for measurement of the rest of oxygen

- See Basic Documentation P7550

**LMV52** with **PLL52**

**Mounting flange** for QGO21

**AGO21.000A**

**Flange gasket** for service

**5 769 2021 0**

**Sinter filter** for service

**AGO742870012**

- To be fixed to the QGO21 with screws with a width over flats of SW41

- Single packing

- See Mounting instruction M7845 (74 319 0877 0)



## 4 Technical data

### QGO21

Operating voltage of measuring cell's	
- QGO21.000D27	AC 230 V $\pm$ 15%
- QGO21.000D17	AC 120 V $\pm$ 15% (only with LMV52 and PLL52)
Mains frequency	50/60 Hz $\pm$ 6%
Power consumption	Max. 90 W, typically 45 W (controlled)
Perm. mounting position	Refer to Mounting Instructions M7845 (74 319 0866 0)
Degree of protection	IP40, to be ensured through installation
Protection class	I
Weight (net)	Approx. 1,2 kg
Signal lines	
- Shielded 6-core cable	Twisted pairs
- Shielding connected to terminal GND of the PLL52	
- Proposal for cable	LifYCY3x2x0.2 or LYCY3x2x0.2
Measuring system	Zirconium dioxide measuring cell as an oxygen ion conductor
Perm. flow rate of flue gas (only with AGO21)	1...10 m/s
Perm. types of fuel	Light oil (EL) or natural gas (H) Heavy oil to DIN 51603-3 and DIN 51603-5
Measuring range	0.2...20.9% O <sub>2</sub>
Perm. cable length between QGO21 and PLL52	Max. 10 m
Supply lines (mains cable)	Wire dia. min. 1 mm <sup>2</sup> (e.g. NYM3 x 1.5)
Required operating temperature of measuring cell	700 °C $\pm$ 50 °C
Tightening torque for sintered filters	Min. 6 Nm Max. 7 Nm
Measuring time	Approx. 12 min

### Environmental conditions

<b>Storage</b>	DIN EN 60721-3-1
Climatic conditions	Class 1K3
Mechanical conditions	Class 1M2
Temperature range	-20...+60 °C
Humidity	<95% r.h.
<b>Transport</b>	DIN EN 60721-3-2
Climatic conditions	Class 2K2
Mechanical conditions	Class 2M2
Temperature range	-25...+70 °C
Humidity	<95% r.h.
<b>Operation</b>	DIN EN 60721-3-3
Climatic conditions	Class 3K5
Mechanical conditions	Class 3M2
Temperature range	
- Flange	Max. 250 °C
- Connecting head	Max. 70 °C
- Flue gas	$\leq$ 300 °C
Humidity	<95% r.h.



**Attention!**  
Condensation, formation of ice and ingress of water are not permitted!

### AGO21

Tube	DN50, steel X5 CrNi 18 9
Tube length	48 mm
Flange	DN50, steel X5 CrNi 18 9

## 5 Description of functions

### 5.1 Functioning principle of the measuring cell

The measuring cell of the QGO21 is made of ceramics ( $ZrO_2$ ) stabilized with  $Y_2O_3$ . At temperatures above  $500\text{ }^\circ\text{C}$ , oxygen ions can diffuse through the ceramics material. It carries a porous platinum layer on both sides, which serve as electrodes.

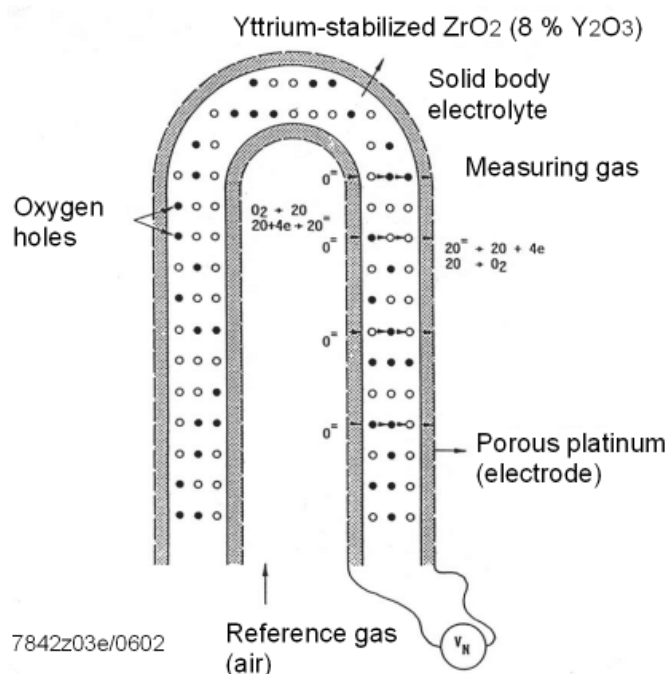

Figure 2: Functioning principle of the measuring cell

The diffusion of ions starts when concentrations on both sides of the cell differ. The diffusion of oxygen ions carries electrical charges that generate an electrical field across the platinum electrodes. When in equilibrium, the diffusion force compensates the force of the electrical field. On the one hand, the porous platinum electrodes serve for the catalytic conversion of the molecules into ions, and vice versa ( $O_2 \Leftrightarrow 2O + 2e$ ), on the other, for the acquisition of voltage. The voltage across the electrodes is the so-called Nernst voltage. The magnitude of this voltage is dependent on the difference in oxygen concentration and the cell's temperature.

$$V_N = \frac{R \times T}{4 \times F} \ln \frac{O_2\text{-Ref.}}{O_2} = (\text{mV})$$

where	$V_N$	=	Nernst voltage
	$R$	=	gas constant 8.3 J/K
	$F$	=	Faraday constant 96.486 As
	$T$	=	absolute cell temperature (K)
	$O_2\text{-Ref.}$	=	Oxygen content of reference gas (air: 20.9%)
	$O_2$	=	oxygen content of measured gas

that is  $= \frac{R}{4 \times F} = 21.5 \frac{\mu V}{K}$  or

$\frac{R \times T}{4 \times F} = 20.9 \text{ mV}$  at  $T = 700 \text{ }^\circ\text{C} = 973 \text{ K}$

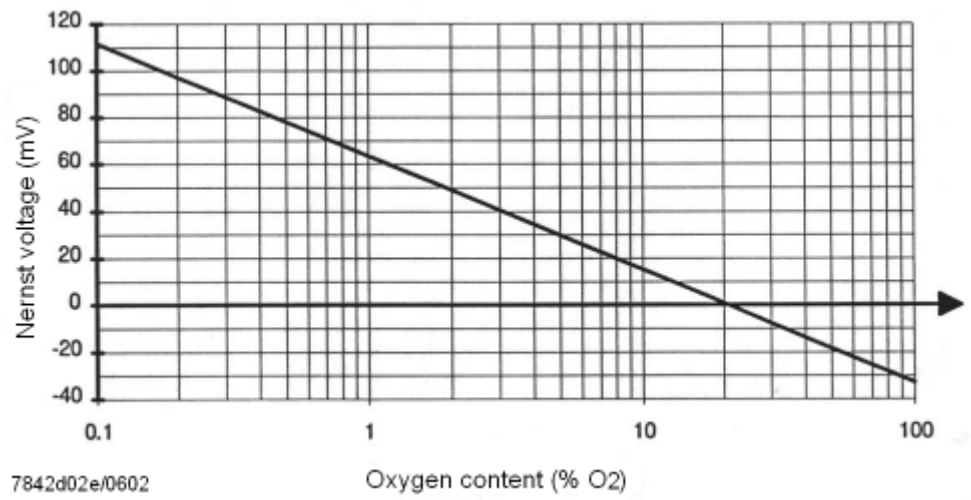

Figure 3: Nernst voltage as a function of the oxygen concentration at a cell temperature of 700 °C

## 5.2 Impact of the cell's temperature

The slope of the curve changes on a change of cell temperature.

The lower the temperature, the lower the Nernst voltage and the higher the displayed oxygen concentration.

The higher the temperature, the higher the Nernst voltage and the lower the displayed oxygen concentration.

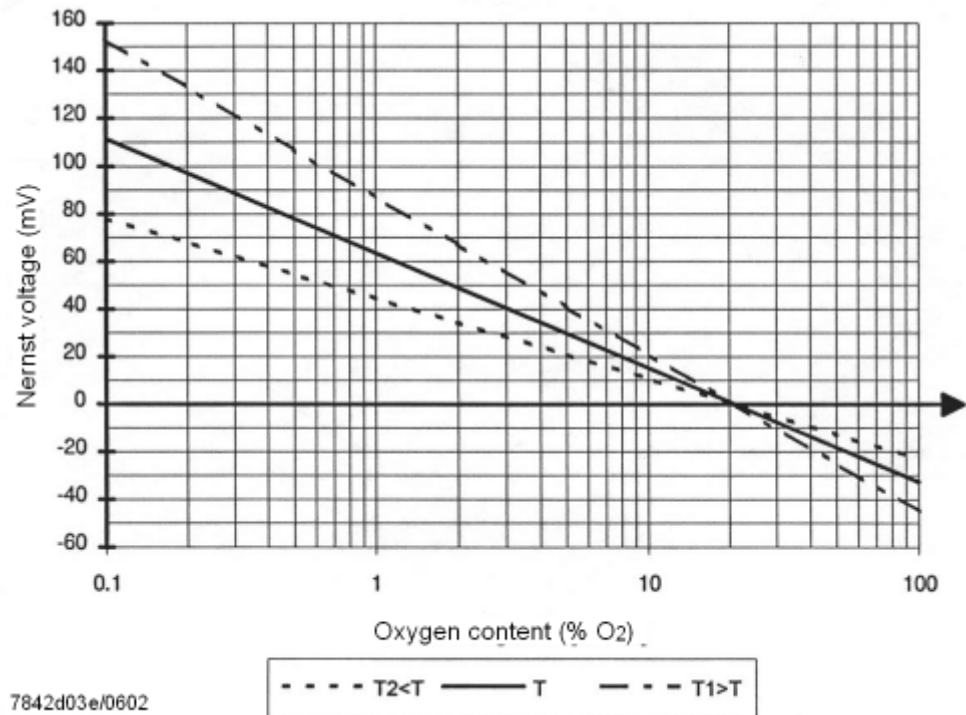

Figure 4: Impact of the cell's temperature on the oxygen value

To limit the error, the temperature in the PLL52 is also considered when calculating the oxygen value and monitored for a minimum temperature.

The actual temperature is continuously acquired and serves as an input variable for controlling the cell's temperature and for calculating the actual oxygen content.

## 5.3 Impact of the reference gas

When the oxygen concentration of the reference gas changes, the point of intersection of the straight line with the abscissa will change (20.9%).

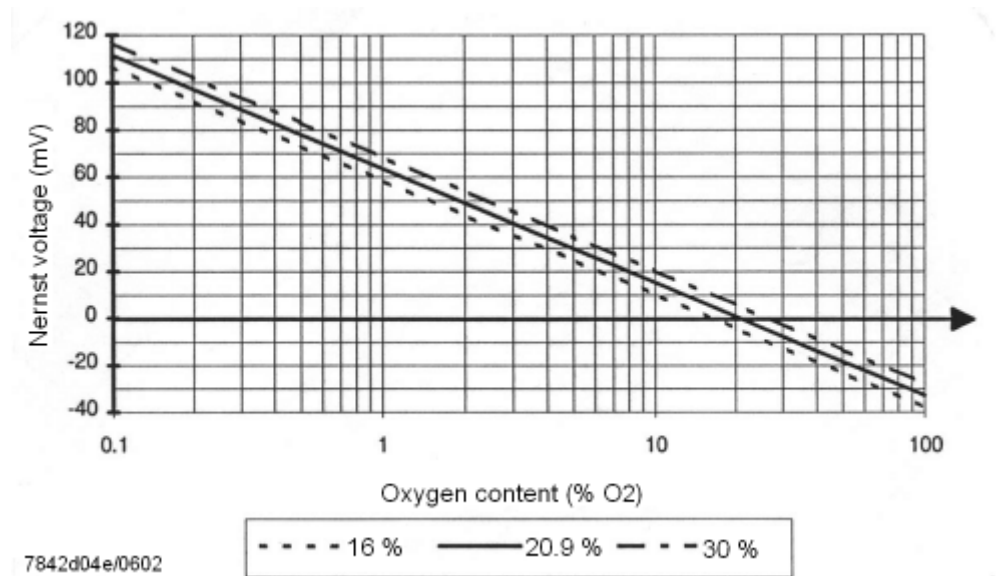

Figure 5: Nernst voltage as a function of the reference gas



### Note

The QGO21 is a device that does not measure the absolute but the relative oxygen value.

The result is calculated based solely on the ratio of the partial pressures of the reference gas (ambient air) and the measuring gas.

## 5.4 Switching on and switching off

When switching the sensor on or off, temperature differences generate thermo-electric voltages of up to 100 mV (both positive and negative).

These can produce erroneous measurements during the heating up phase.

It is recommended to observe the heating up times specified in *Engineering notes*.

## 5.5 Aging

Due to aging, the characteristics internal resistance and electrical response time can change.

The LMV52 with PLL52 measures these characteristics at regular intervals and triggers an alarm should programmable limits be exceeded.

Assessment of aging with the help of the LMV52 with PLL52 and AZL52

On the display, the following value can be checked:

- Internal resistance: Max. 150  $\Omega$

If these limit is exceeded, the QGO21 must be replaced.

## 6 Mechanical design of the sensor

The function of the oxygen sensor is ensured by the following components:

- 1) **Thermocouple**  
The thermocouple acquires the temperature in the cell and delivers a signal of about  $40 \mu\text{V/K}$ , which is used for temperature control.
- 2) **Flue gas guidance**  
Exchanges the measurement gases in the measuring cell area.
- 3) **Sinter filter**  
Protects the measuring cell, heating and flue gas guidance from contamination caused by flue gases.
- 4) **Heating**  
The heating maintains the cell's temperature at  $700 \text{ }^\circ\text{C}$ .
- 5) **Measuring cell**  
The measuring cell acquires differences in oxygen concentrations and delivers a Nernst voltage.
- 6) **Connecting head**  
The connecting head contains the sensor's connection terminals and the temperature compensation element. The compensation element delivers a current of about  $1 \mu\text{A/K}$  which represents the temperature inside the head. The sum of head temperature and thermocouple temperature gives the absolute temperature in the measuring zone (normally  $973 \text{ K}$ ).
- 7) **Reference air slots**  
The slots are used for exchanging the air with fresh ambient air and must remain free at all times to ensure unimpeded air exchange.

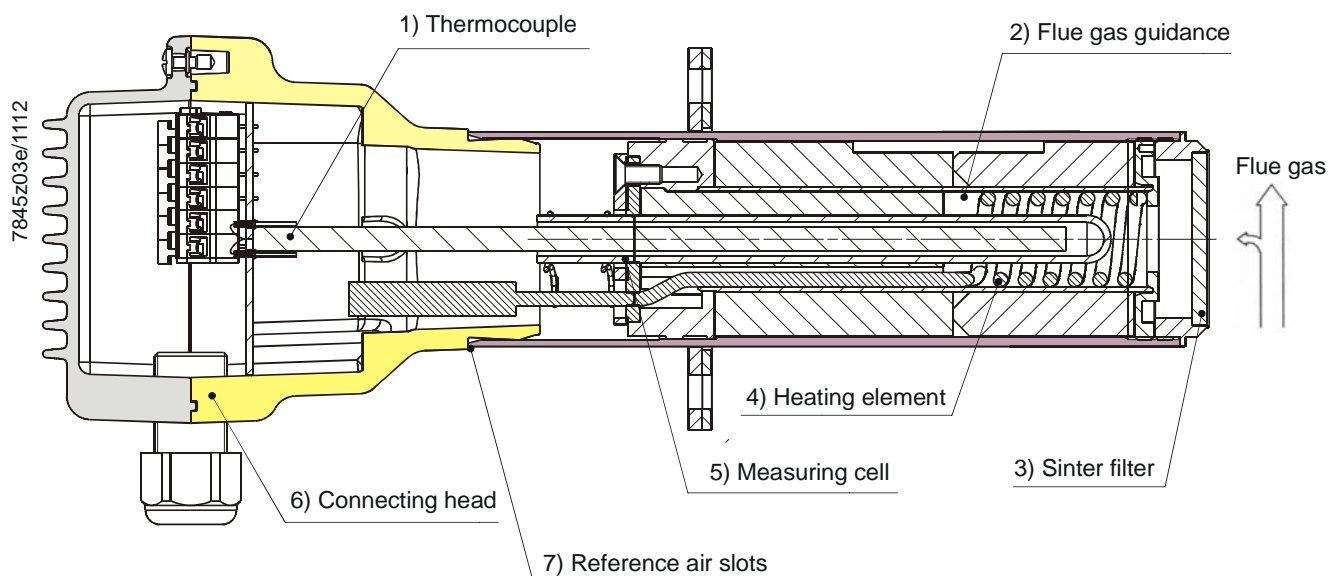

Figure 6: Mechanical design of the oxygen sensor

# 7 Mounting and connecting the sensor

## 7.1 Mounting

To simplify mounting in the chimney, AGO21 mounting flange is available.

For mounting position, refer to Mounting Instructions M7845 (74 319 0866 0).  
The AGO21... must only be installed horizontally (Figure 7).

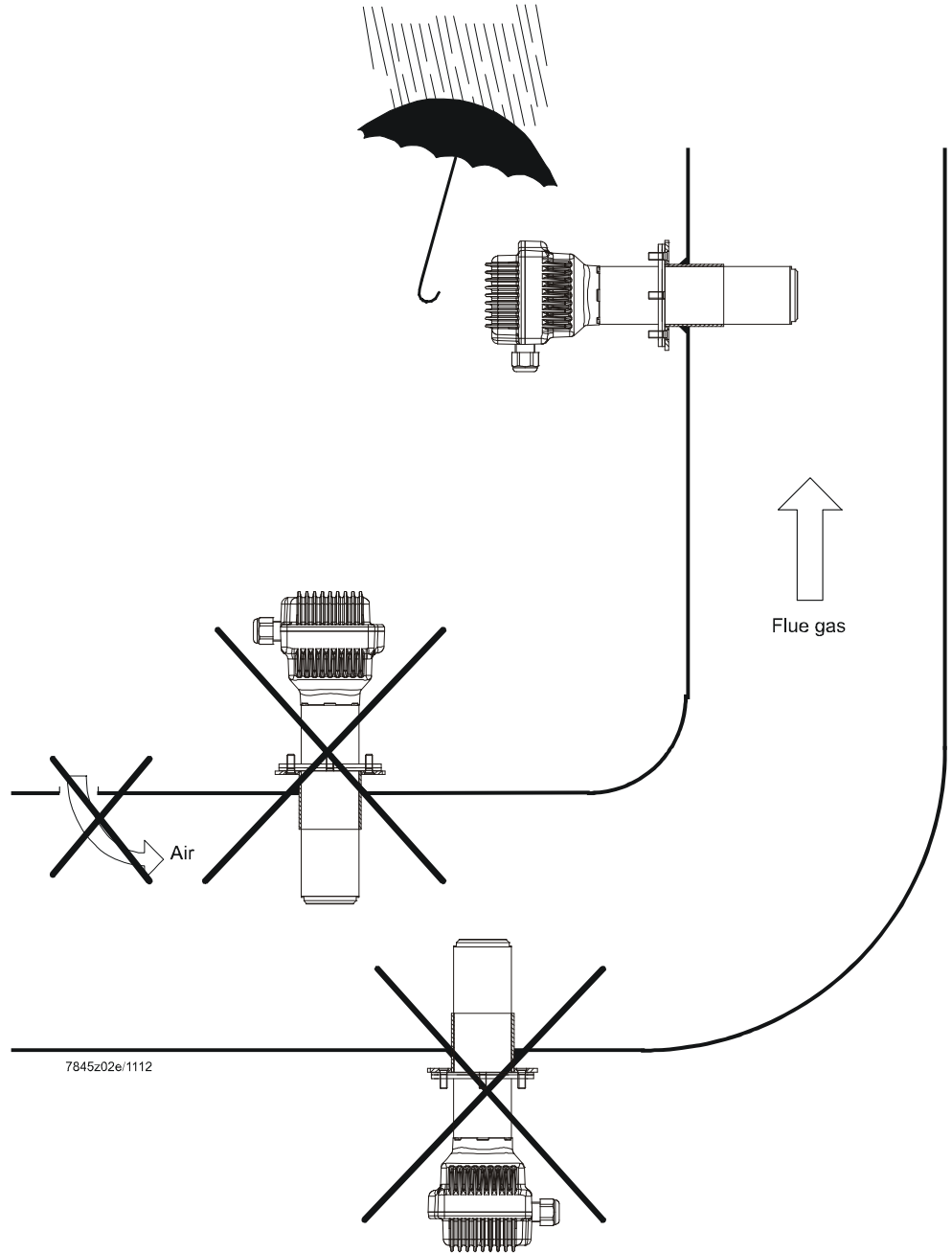

Figure 8: Mounting position of QGO21

## 7.2 Connection

Figure 8 shows the connection of the QGO21 to the PLL52



### Note

The signal lines require shielded 6-core cables with twisted pairs.  
The shielding is to be connected to terminal GND of the PLL52.

- Open the cover only when the main switch is off so that both live and neutral conductors are disconnected
- There is a risk of burning since the measuring cell works at an operating temperature of 700 °C

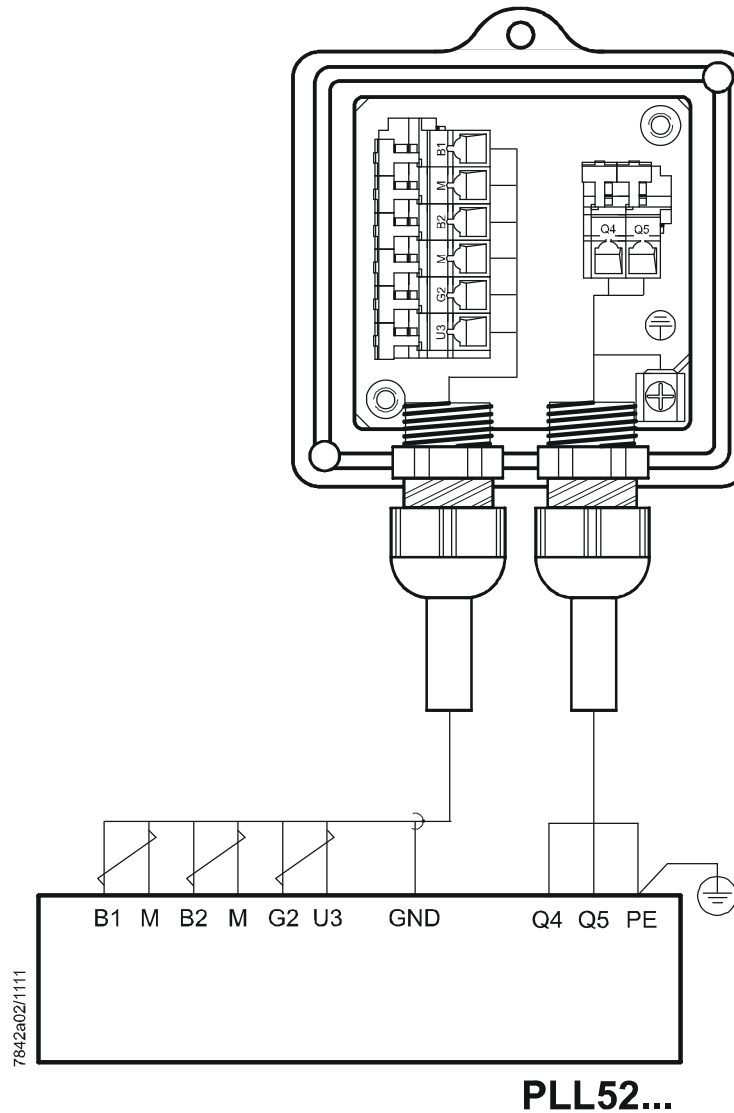

Figure 9: Connection QGO21

## 8 Connection diagram

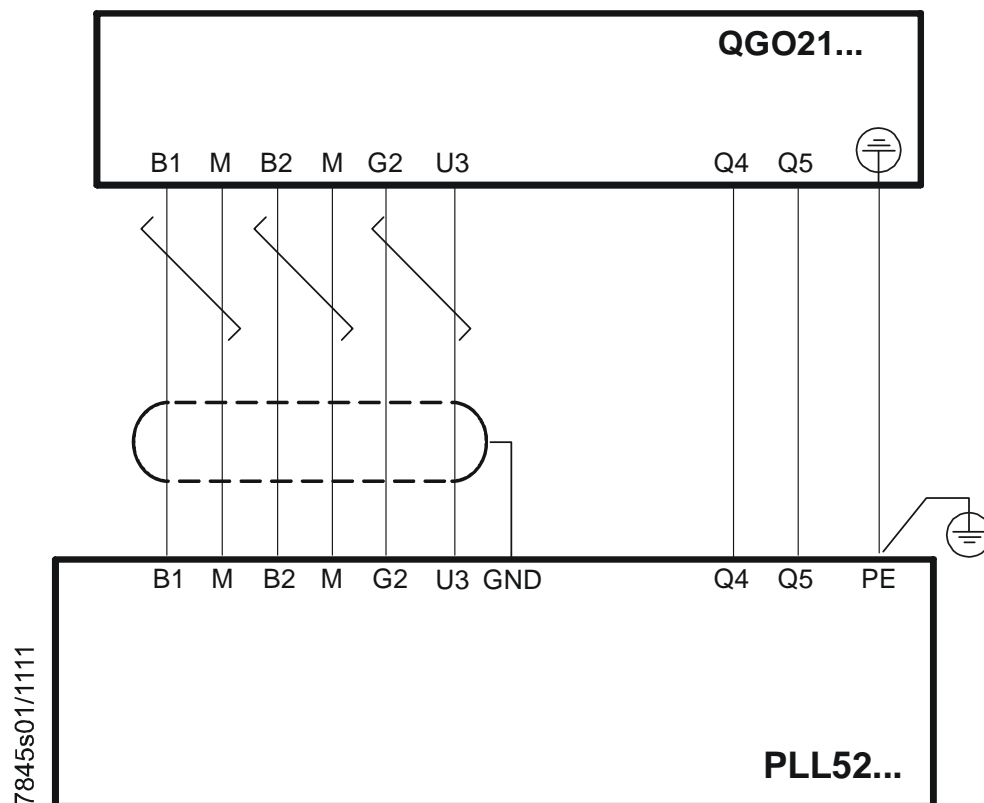



Figure 10: Connection diagram

### Legend

B1	(+)	Signal of oxygen measuring cell
B2	(+)	Thermocouple voltage
G2	(-)	Supply temperature compensation element
GND		Electrical ground for shielding
M	(-)	Electrical ground for signals <b>B1</b> and <b>B2</b>
M	(-)	
Q4		Sensor heating with mains connection
Q5		Sensor heating with mains connection
U3	(+)	Signal of temperature compensation element
		Protective earth (PE)

# 9 Dimensions

Dimensions in mm

QGO21.000D27

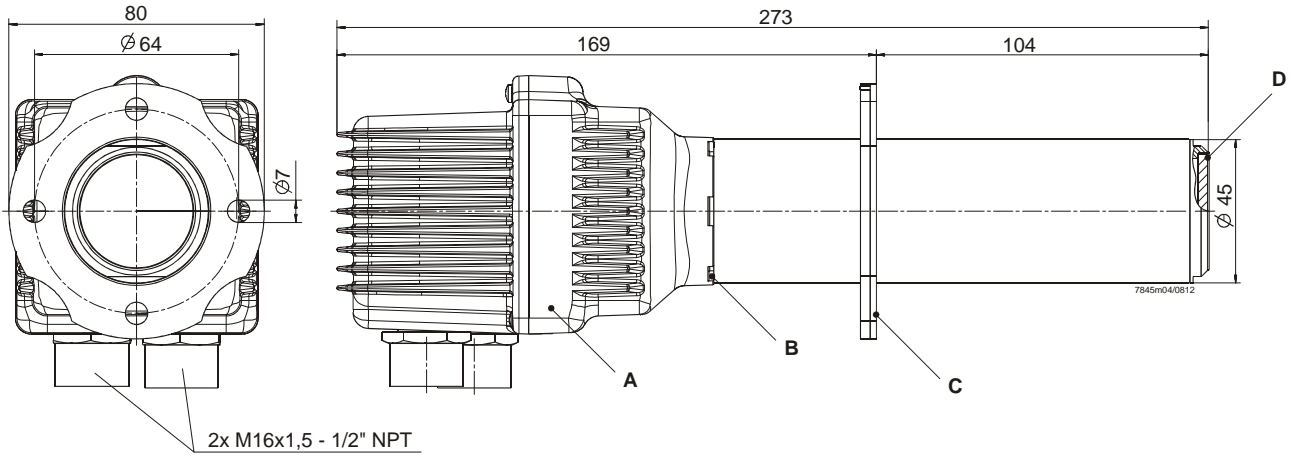

Figure 11: Dimension QGO21.000D27

QGO21.000D17

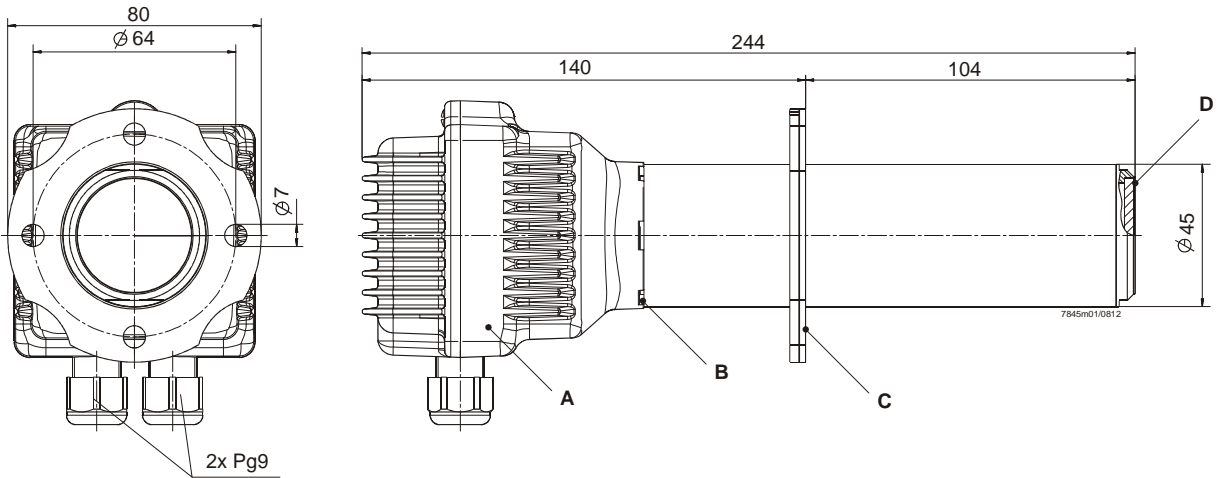

Figure 12: Dimension QGO21.000D17

Legend

- A Sensor head
- B Reference air slots
- C Flange gasket (included)
- D Sinter filter

AGO21...

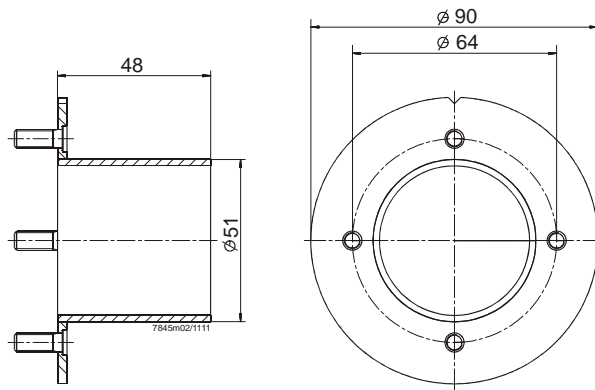

Figure 13: Dimension AGO21...

AGO742870012

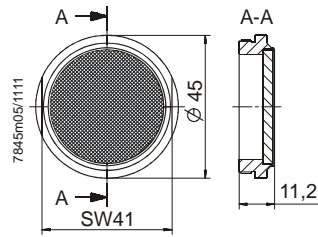

Figure 14: Dimension AGO7428700120

# 10 Comparison table

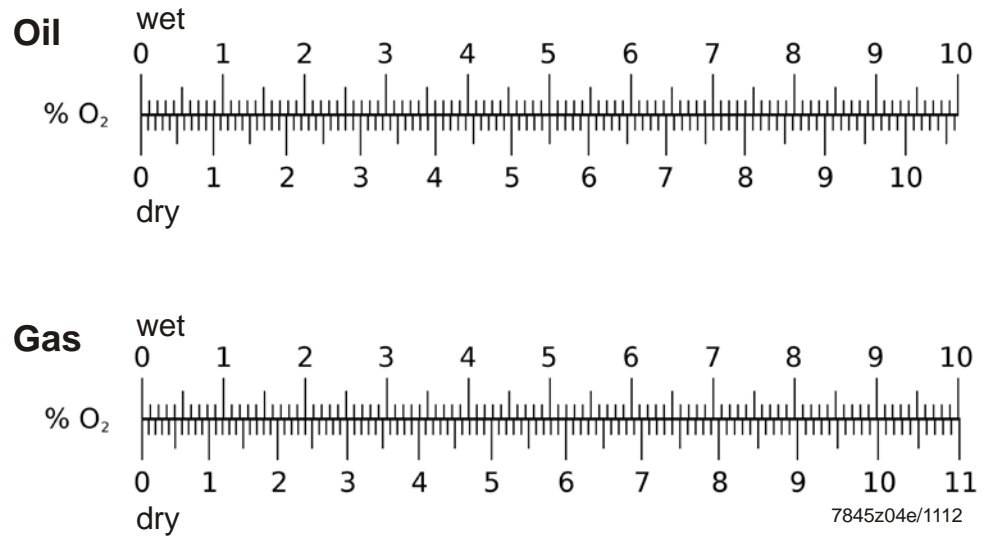

Figure 15: Comparison table for different flue gas analysis devices (in %!)



**Note!**

Additional humidity is not taken into account and may distort the measured value.  
Example: Urea injection.

# 11 List of figures

---

Figure 1: Example General overview .....	11
Figure 2: Functioning principle of the measuring cell .....	14
Figure 3: Nernst voltage as a function of the oxygen concentration at a cell temperature of 700 °C .....	15
Figure 4: Impact of the cell's temperature on the oxygen value .....	16
Figure 5: Nernst voltage as a function of the reference gas .....	17
Figure 6: Mechanical design of the oxygen sensor .....	18
The AGO21... must only be installed horizontally (Figure 7). .....	19
Figure 8: Mounting position of QGO21 .....	19
Figure 9: Connection QGO21 .....	20
Figure 10: Connection diagram .....	21
Figure 11: Dimension QGO21.000D27 .....	22
Figure 12: Dimension QGO21.000D17 .....	22
Figure 13: Dimension AGO21.....	23
Figure 14: Dimension AGO7428700120 .....	23
Figure 15: Comparison table for different flue gas analysis devices (in %)! .....	24

# 12 Index

<b>A</b>		
<b>Assortment connections</b> .....	13	
<b>C</b>		
<b>Comparison table</b> .....	25	
Connecting head .....	19	
<b>Connection diagram</b> .....	22	
<b>D</b>		
<b>Description of functions</b> .....	15	
<b>Aging</b> .....	18	
Assessment of aging with the help of the LMV52 with PLL52 and AZL52 .....	18	
<b>Functioning principle of the measuring cell</b> ...	15	
<b>Impact of the cell's temperature</b> .....	17	
<b>Impact of the reference gas</b> .....	18	
<b>Switching on and switching off</b> .....	18	
Dimension		
AGO21 .....	24	
AGO742870012 .....	24	
<b>Dimensions</b> .....	23	
QGO21.000D17 .....	23	
QGO21.000D27 .....	23	
<b>F</b>		
Flue gas guidance .....	19	
<b>H</b>		
Heating .....	19	
<b>M</b>		
Measuring .....	19	
		<b>Mechanical design of the sensor</b> .....
		19
		<b>Mounting and connecting the sensor</b> .....
		20
		<b>Connection</b> .....
		21
		<b>Mounting</b> .....
		20
		<b>O</b>
		<b>Overview</b> .....
		12
		<b>R</b>
		Reference air slots .....
		19
		<b>S</b>
		<b>Safety notes</b> .....
		4
		<b>Commissioning notes</b> .....
		8
		<b>Disposal notes</b> .....
		11
		<b>Electrical connection</b> .....
		7
		<b>Engineering notes</b> .....
		6
		Functional check .....
		9
		<b>Installation and mounting notes</b> .....
		6
		<b>Service notes</b> .....
		10
		<b>Standards and certificates</b> .....
		10
		<b>Warning notes</b> .....
		4
		Sinter filter .....
		19
		<b>T</b>
		<b>Technical data</b> .....
		14
		<b>AGO21</b> .....
		14
		<b>Environmental conditions</b> .....
		14
		<b>QGO21</b> .....
		14
		Thermocouple .....
		19

Siemens AG Building Technologies Division  
Berliner Ring 23  
D-76437 Rastatt  
Tel. +49 7222 598-279  
Fax +49 7222 598-269  
www.siemens.com

© 2016 Siemens AG Building Technologies Division  
Subject to change!