

## TS Series

---

### TS... Protocol Converter

For use with LMV3..., LMV5..., RWF..., and TS... Series Controls



---

### Description

A TS... series protocol converter provides a flexible communication interface to the building management system (BMS) for streamlined data collection and monitoring.

---

## Features

- Converts native Modbus/RTU to BACnet/IP, BACnet MS/TP, Ethernet/I/P Metasys N2, Modbus TCP/IP, or LonWorks
- Allows simultaneous connection of up to 64 devices via serial connections, and up to 12 devices via Ethernet Modbus TCP/IP connections
- Easily configured using web browser
- 61 data points per LMV3...
- 153 data points per LMV5...
- 13 data points per RWF10
- 57 data points per RWF40
- 73 data points per RWF55
- 364 data points per TS Series Touchscreen Kit
- 23 data points per TS Series Lead/Lag Master
- 85 data points per TS Series Lead/Lag Master (from each boiler)
- 52 data points per TS Series Deaerator/Surge Tank Master

---

## Application

TS... protocol converter kits are suited for applications with BMS protocol other than Modbus TCP/IP or RTU. All SCC products that communicate using Modbus/RTU are compatible.

---

## Components

All TS... protocol converter kits include the following components:

- Protocol converter module
- Plate kit including power supply and branch circuit protection
- Interconnect terminals for field wiring
- Field port for various protocols

The following options are available:

- Host port for Modbus RTU RS232
- Host port for Modbus RTU RS485
- Ethernet switch to support up to 12 TS... series TCP/IP devices via Ethernet to BMS

## Product Part Numbers

See Table 1 with available kits for protocol converter part number identification:

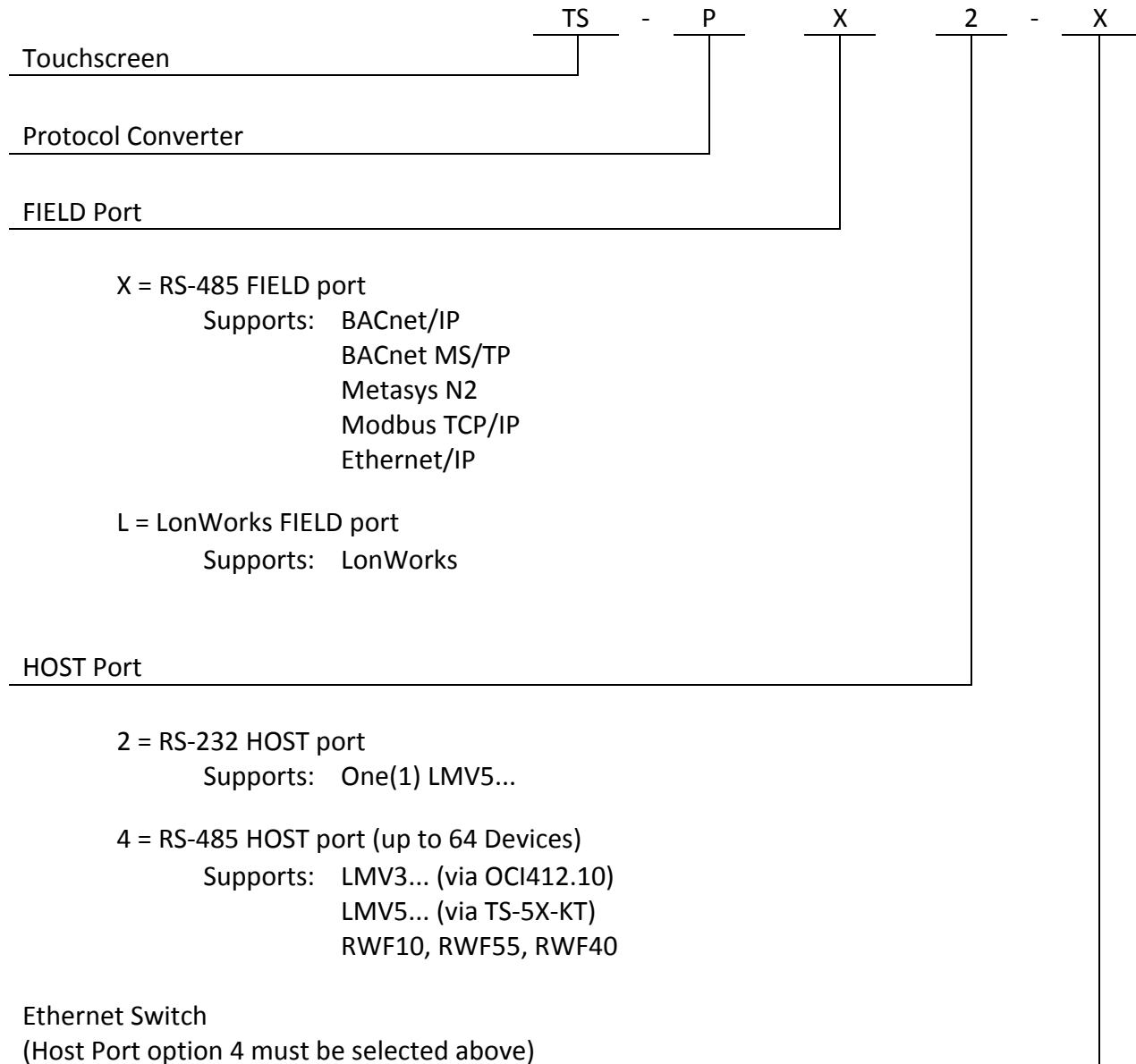

Supports all TS series...Lead/Lag Master Panel, Touchscreen Kits, Combustion Enclosures, and Deaerator/Surge Panels.

- X = None included
- 3 = 5-port switch (up to 3 TS series devices)
- 6 = 8-port switch (up to 6 TS series devices)
- 9 = 13-port switch (up to 9 TS series devices)
- 12 = 16-port switch (up to 12 TS series devices)

**Product Part Numbers (continued)**

**Table 1: TS... Protocol Converter Part Numbers**

Part Number	FIELD Port		HOST Port		Ethernet Switch				
	RS-485	LonWorks	RS-232	RS-485	None	5-port	8-port	13-port	16-port
TS-PX2-X	x		x		x				
TS-PX4-X	x			x	x				
TS-PX4-3	x			x		x			
TS-PX4-6	x			x			x		
TS-PX4-9	x			x				x	
TS-PX4-12	x			x					x
TS-PL2-X		x	x		x				
TS-PL4-X		x		x	x				
TS-PL4-3		x		x		x			
TS-PL4-6		x		x			x		
TS-PL4-9		x		x				x	
TS-PL4-12		x		x					x

---

**Specifications**

Physical characteristics	Operating voltage	110-120 VAC
	Operating frequency	50-60 Hz
	Processor power	24 VDC
	Power consumption	24 VA
Operating environment	Operating temperature	32 to 131 °F [0 to 55 °C]
	Humidity	Max. 85% with no condensation

---

## Dimensions

### TS-PX2-X

LMV5 Modbus RTU to: BACnet/IP, BACnet MS/TP, Ethernet/IP, Metasys N2, or Modbus TCP/IP

### TS-PL2-X

LMV5 Modbus RTU to: LonWorks

### TS-PX4-X

LMV3, LMV5, RWF10, RWF40, and/or RWF55 to: BACnet/IP, BACnet MS/TP, Ethernet/IP, Metasys N2, or Modbus TCP/IP

### TS-PL4-X

LMV3, LMV5, RWF10, RWF40, and/or RWF55 to: LonWorks

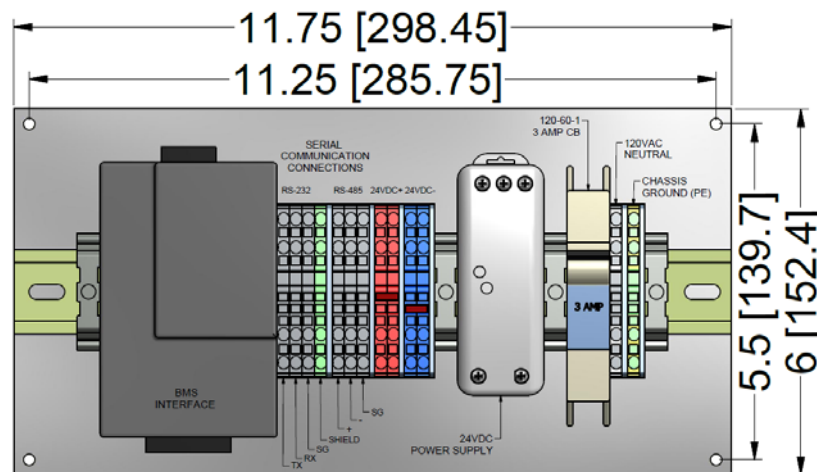

## Dimensions (continued)

### TS-PX4-3

Up to 3 TS...Series Modbus TCP/IP to: BACnet/IP, BACnet MS/TP, Ethernet/IP or Metasys N2

### TS-PL4-3

Up to 4 TS...Series Modbus TCP/IP to: LonWorks

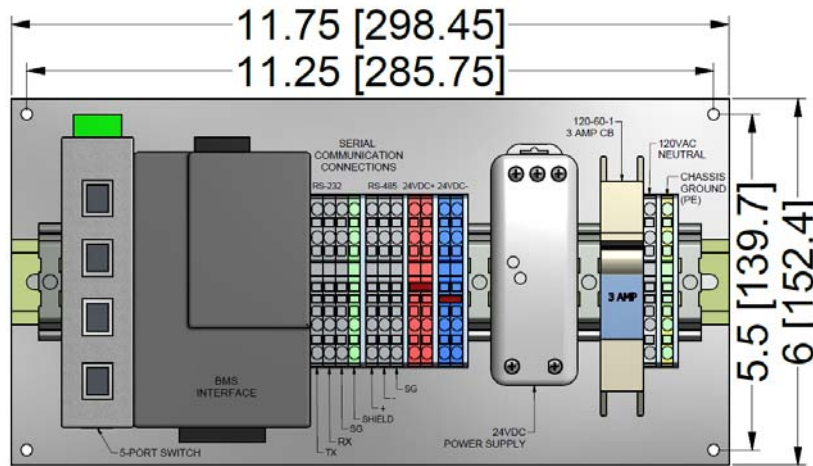

### TS-PX4-6

Up to 6 TS... Series Modbus TCP/IP to: BACnet/IP, BACnet MS/TP, Ethernet/IP, or Metasys N2

### TS-PL4-7

Up to 6 TS... Series Modbus TCP/IP to: LonWorks

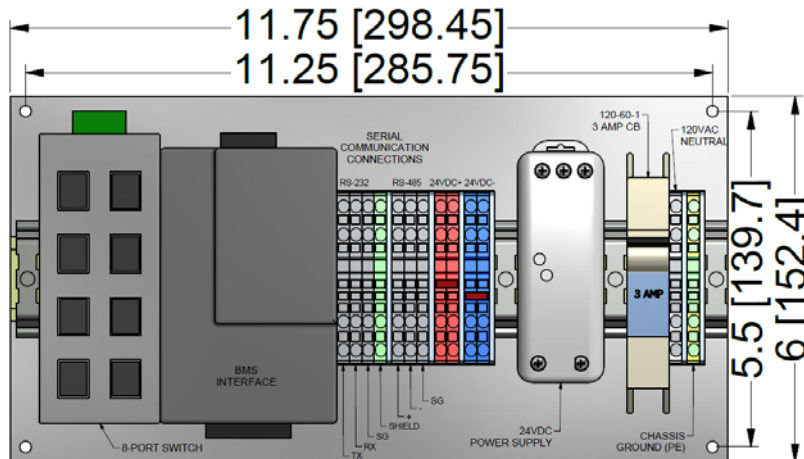

## Dimensions (continued)

### TS-PX4-9

Up to 9 TS... Series Modbus TCP/IP to: BACnet/IP, BACnet MS/TP, Ethernet/IP, or Metasys N2

### TS-PL4-10

Up to 9 TS... Series Modbus TCP/IP to: LonWorks

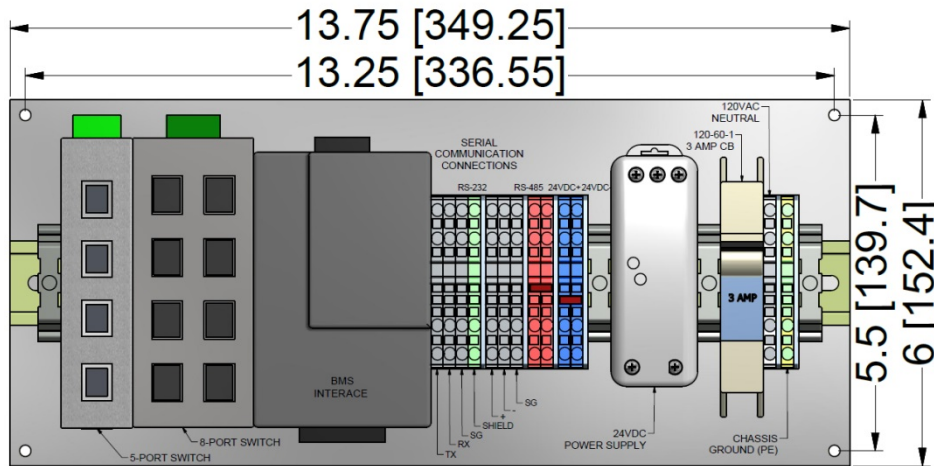

### TS-PX4-12

Up to 12 TS... Series Modbus TCP/IP to: BACnet/IP, BACnet MS/TP, Ethernet/IP, or Metasys N2

### TS-PL4-13

Up to 12 TS... Series Modbus TCP/IP to: LonWorks

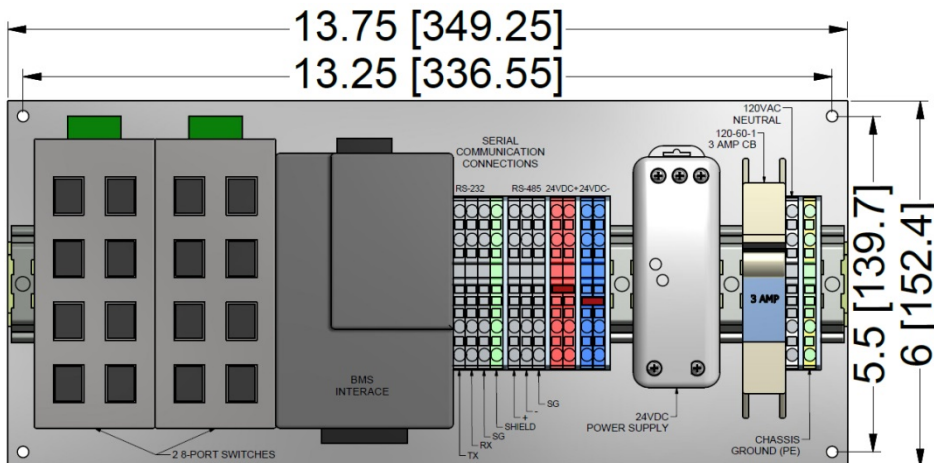

## Connections

### ProtoNode TS-PX2-X (BACnet/IP, BACnet MS/TP, Ethernet/IP, N2 Johnson, or Modbus RTU)

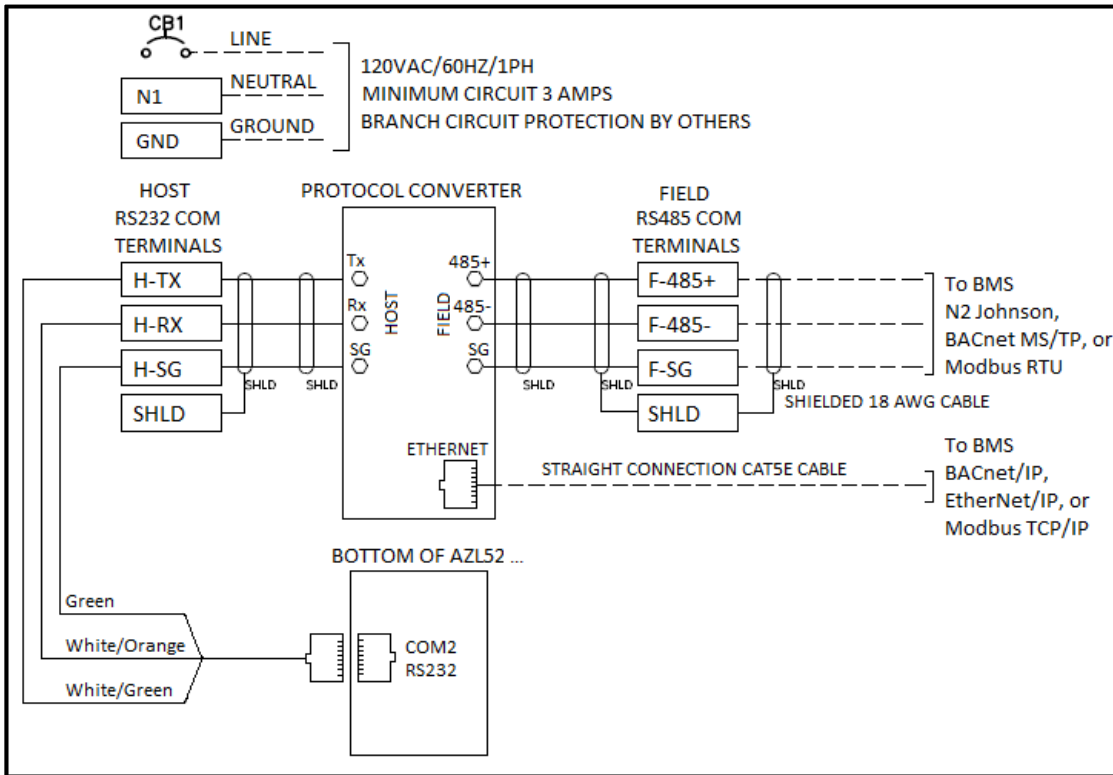

### ProtoAir TS-PX2-X (BACnet/IP, BACnet MS/TP, Ethernet/IP, N2 Johnson, or Modbus RTU)

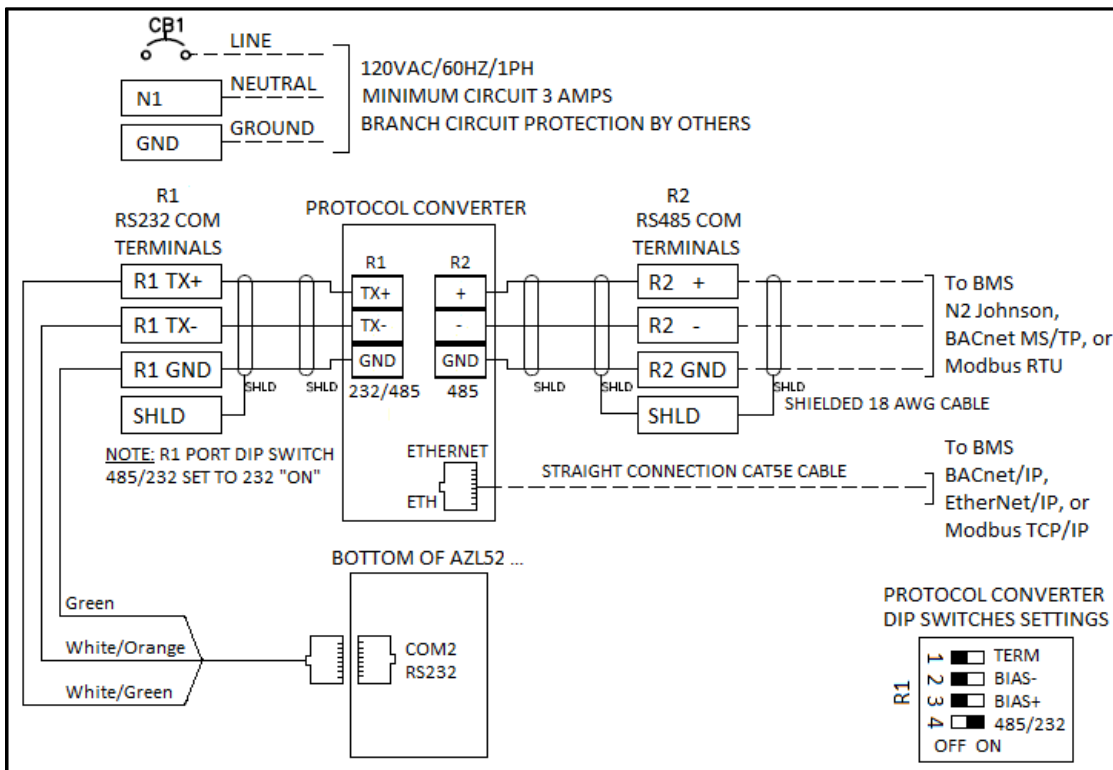

## Connections (continued)

### TS-PL2-X (LonWorks)

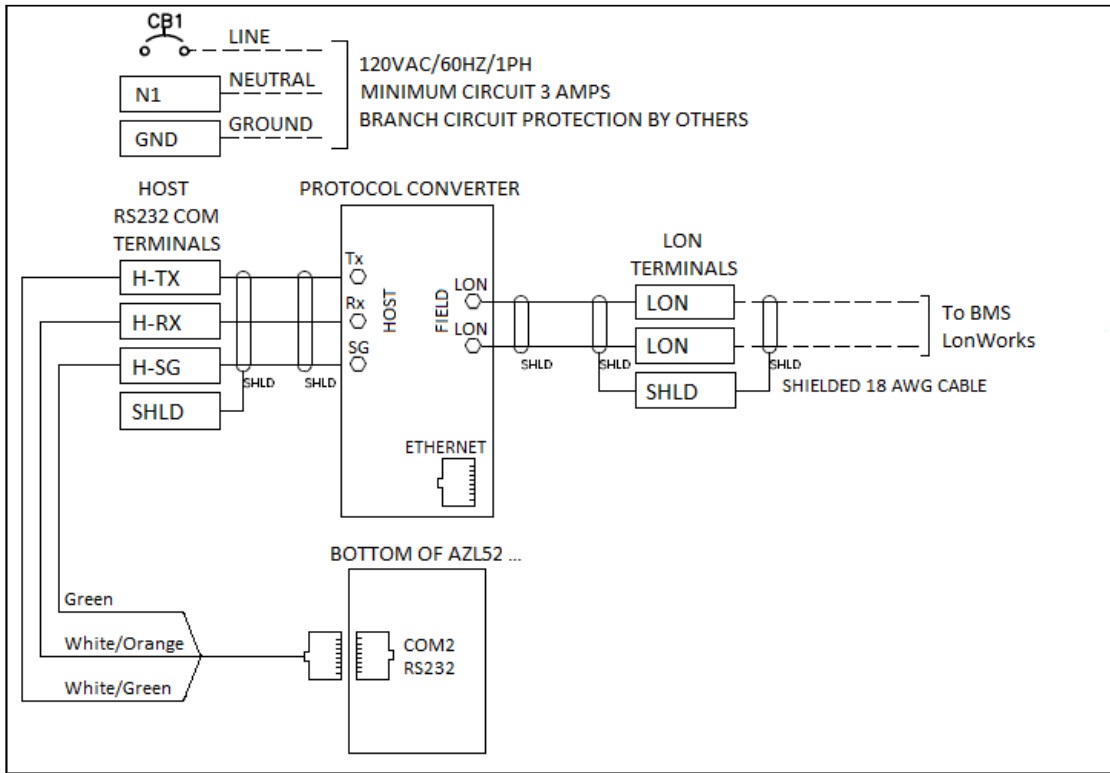

## Connections (continued)

### ProtoNode TS-PX4-X (BACnet/IP, BACnet MS/TP, Ethernet/IP, N2 Johnson, or Modbus RTU)

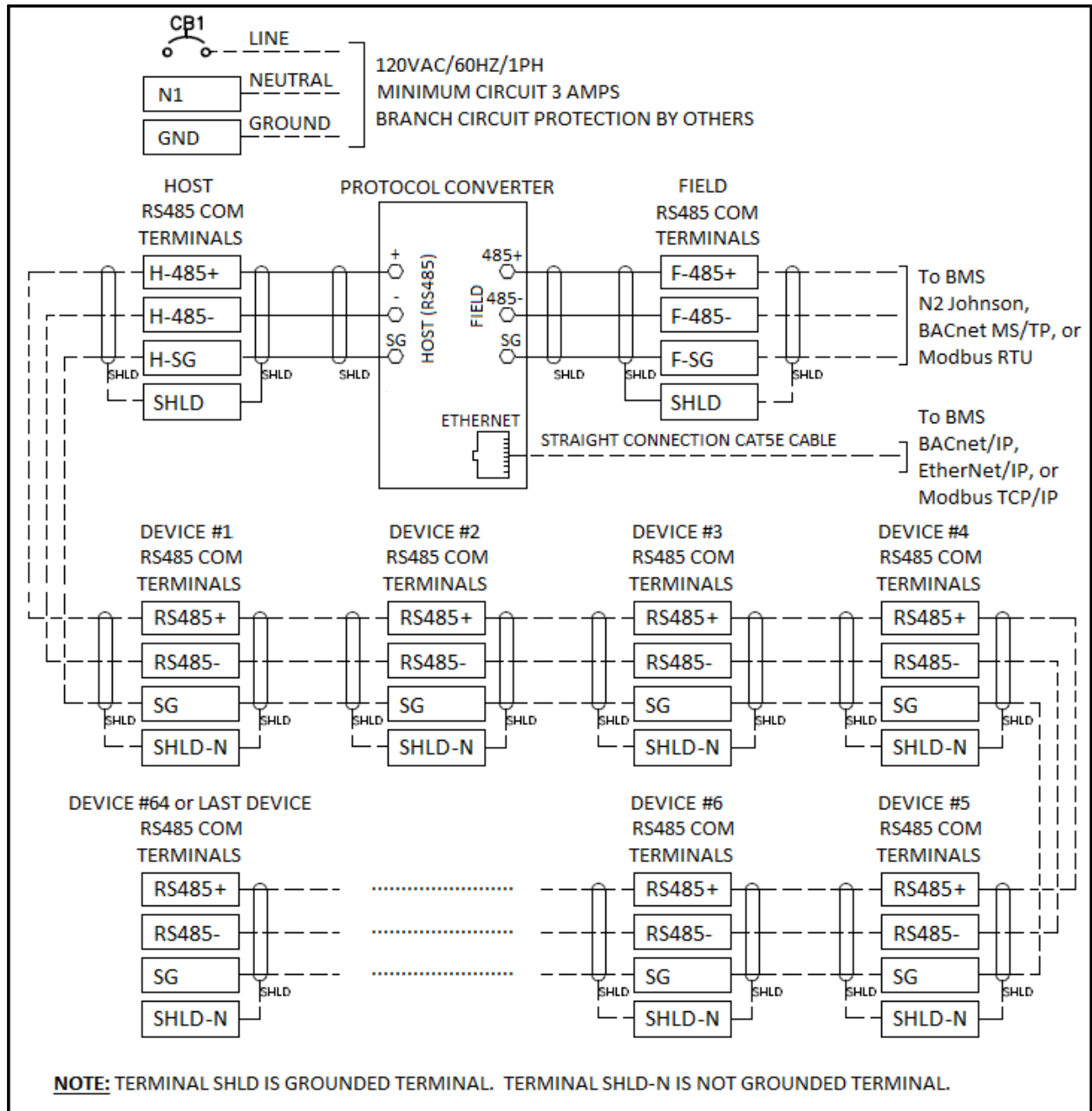

## Connections (continued)

ProtoAir TS-PX4-X (BACnet/IP, BACnet MS/TP, Ethernet/IP, N2 Johnson, or Modbus RTU)

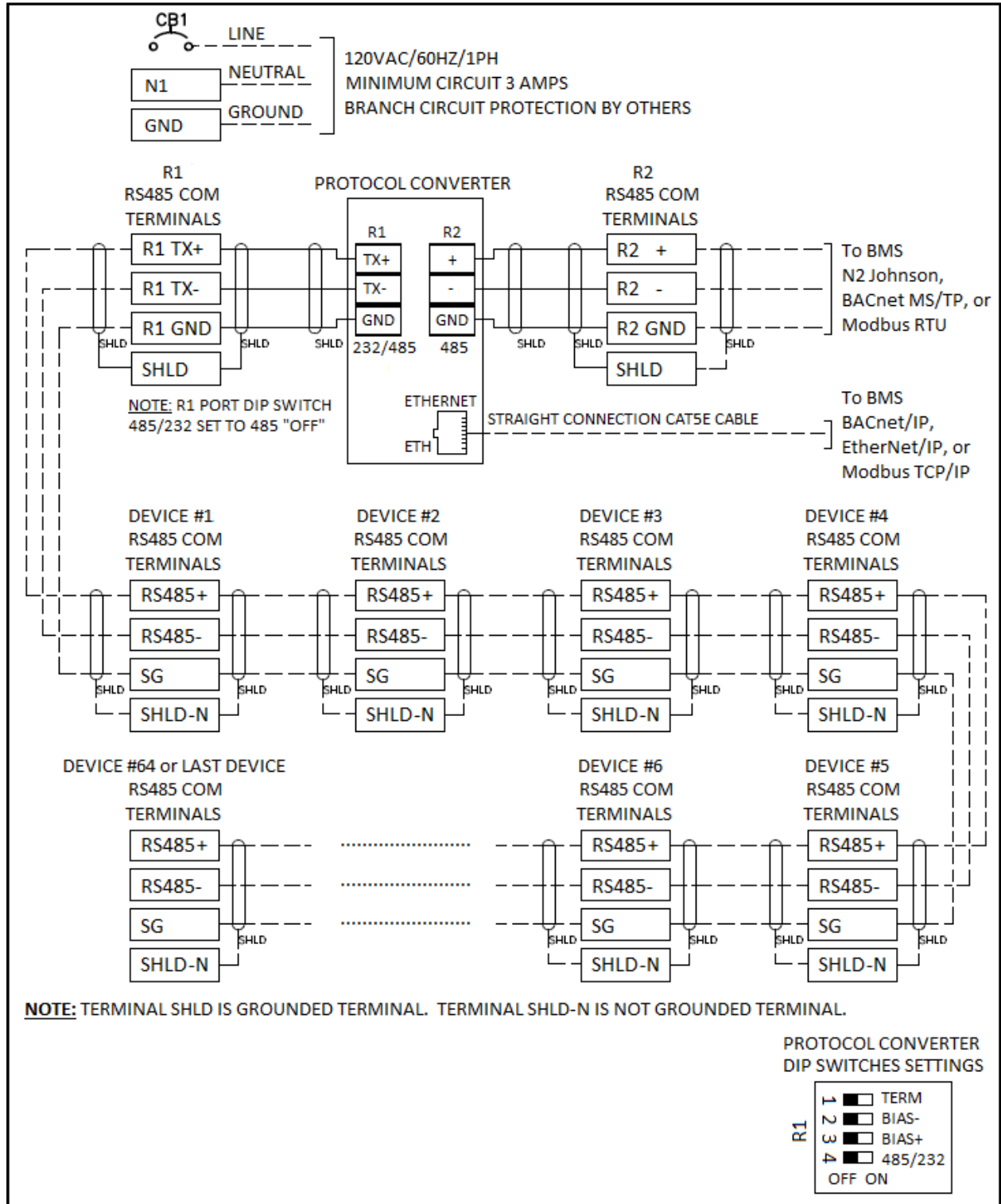

## Connections (continued)

### TS-PL4-X (LonWorks)

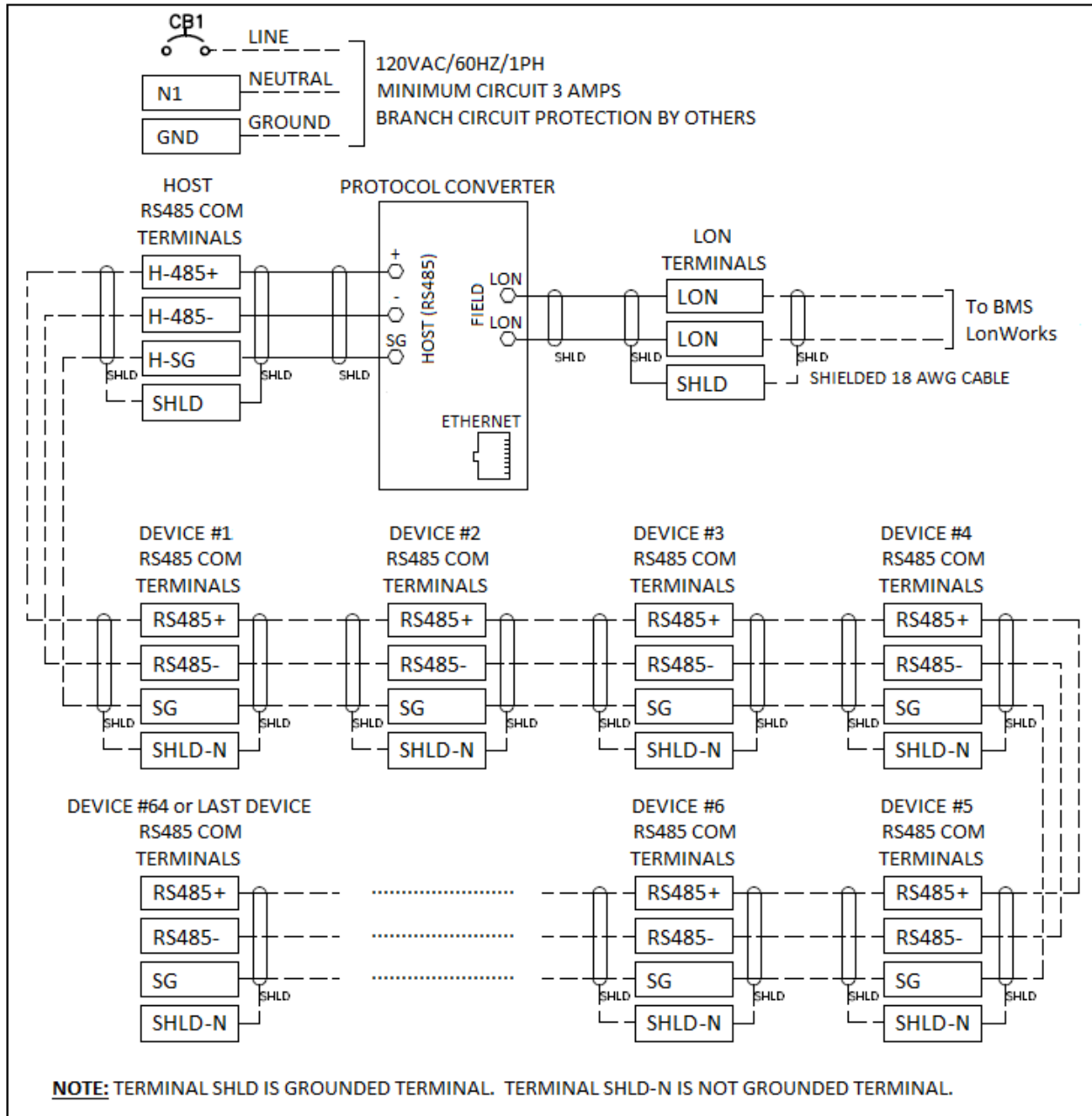

## Connections (continued)

(Host: Ethernet and Serial)

**ProtoNode TS-PX4-3-5 Port Ethernet Switch (BACnet/IP, BACnet MS/TP, Ethernet/IP, N2 Johnson, or Modbus RTU)**

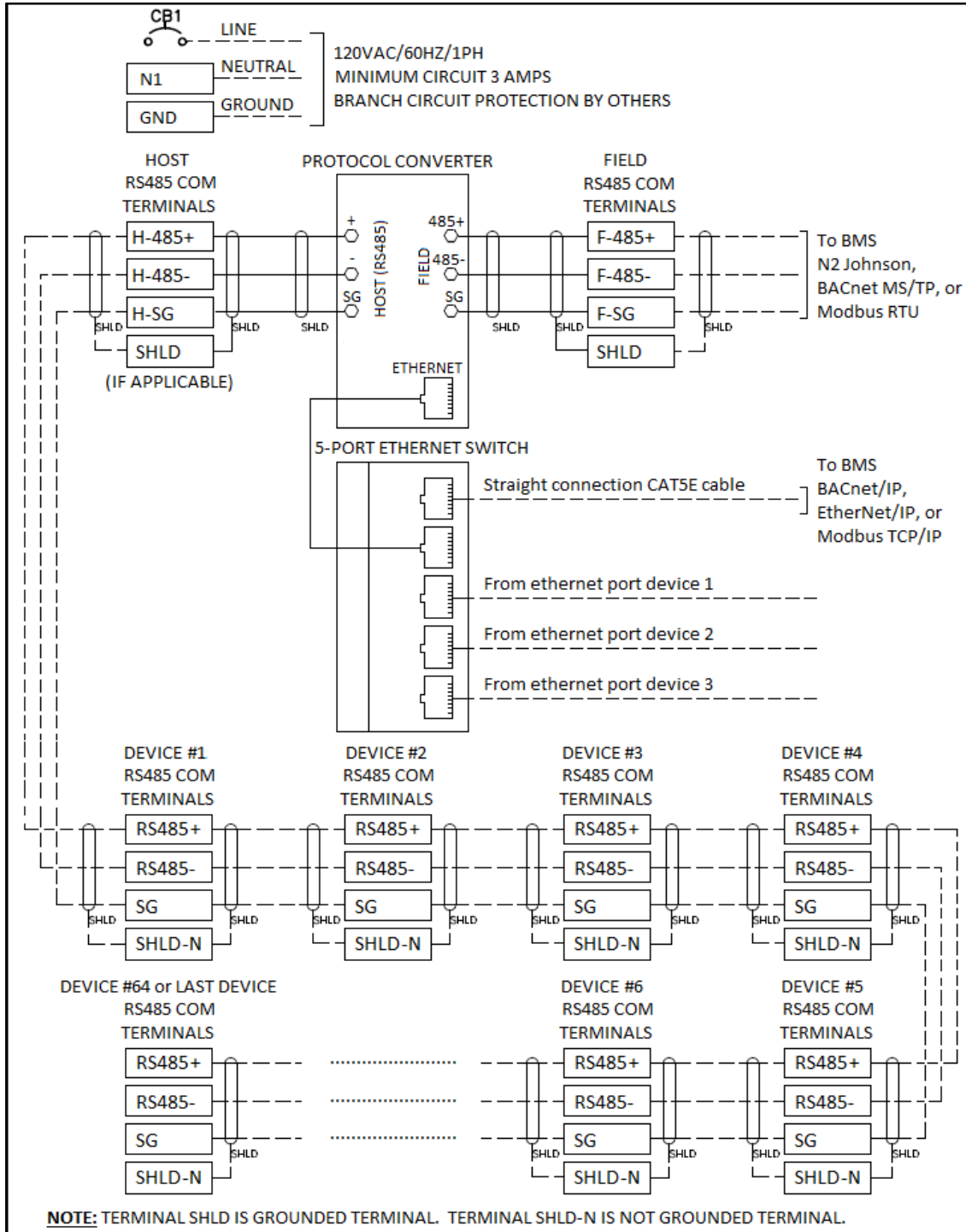

## Connections (continued)

ProtoNode TS-PX4-6-8 Port Ethernet Switch (BACnet/IP, BACnet MS/TP, Ethernet/IP, N2 Johnson, or Modbus RTU)

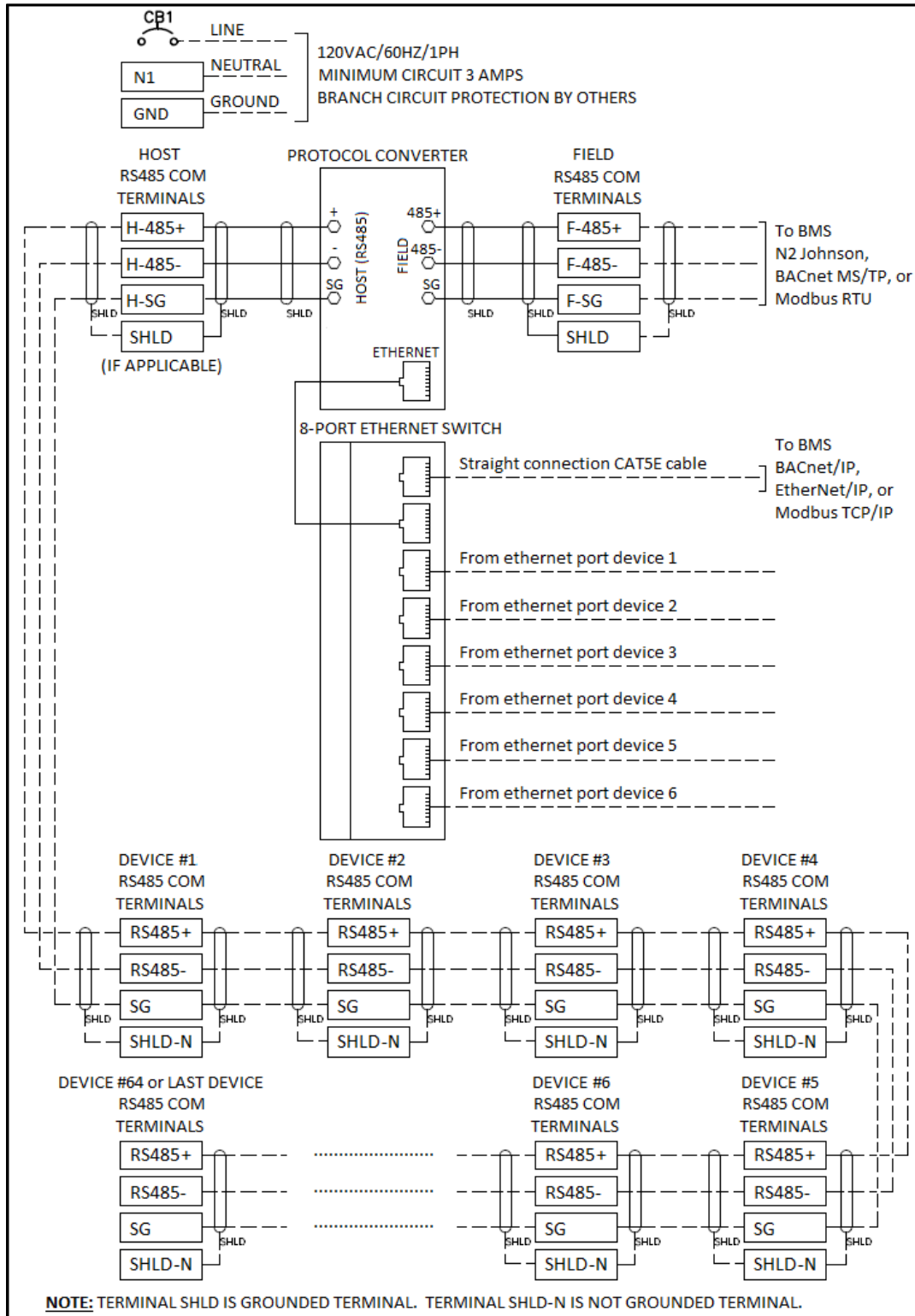

## Connections (continued)

ProtoNode TS-PX4-9-13 Port Ethernet Switch (BACnet/IP, BACnet MS/TP, Ethernet/IP, N2 Johnson, or Modbus RTU)

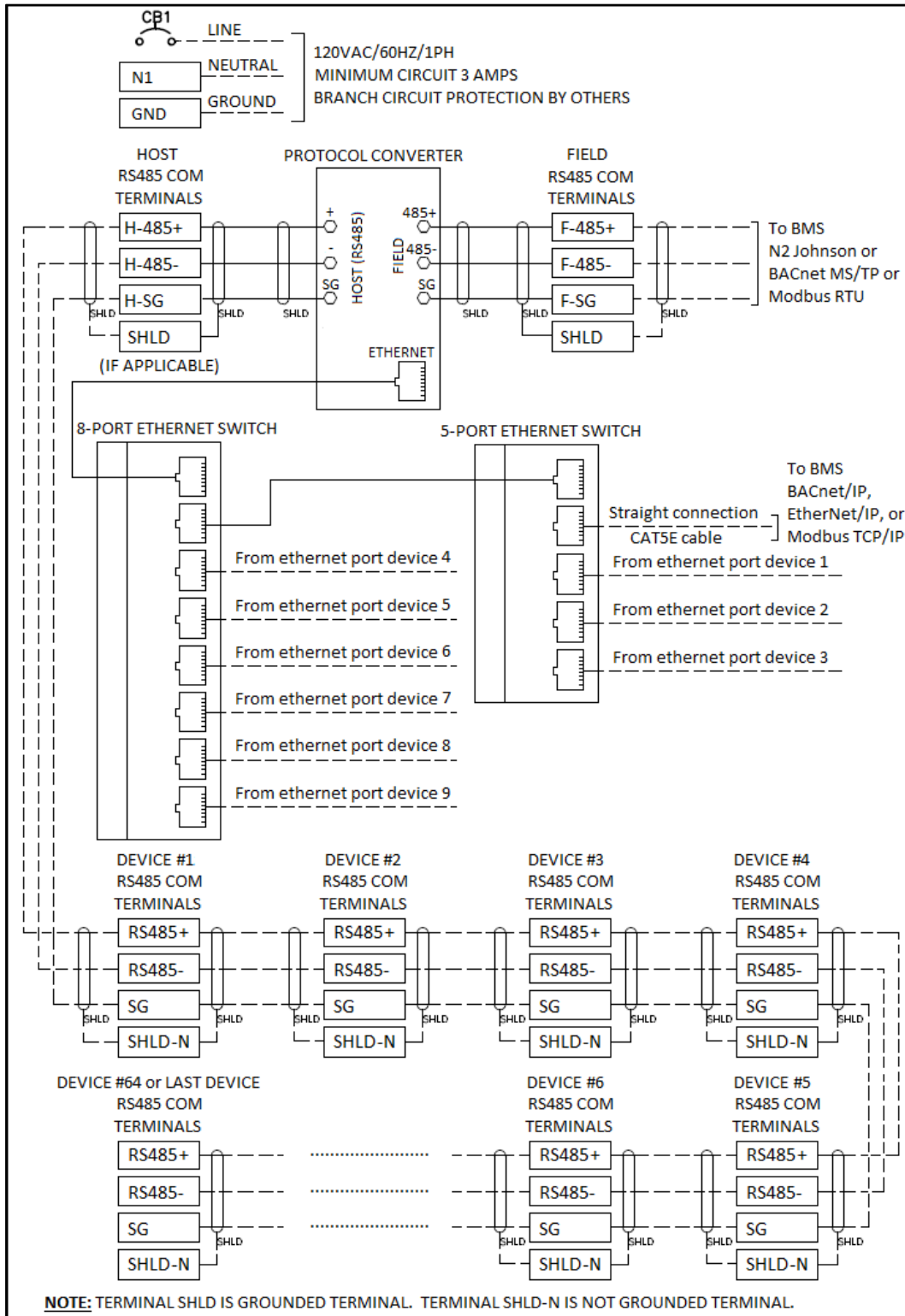

## Connections (continued)

ProtoNode TS-PX4-12-16 Port Ethernet Switch (BACnet/IP, BACnet MS/TP, Ethernet/IP, N2 Johnson, or Modbus RTU)

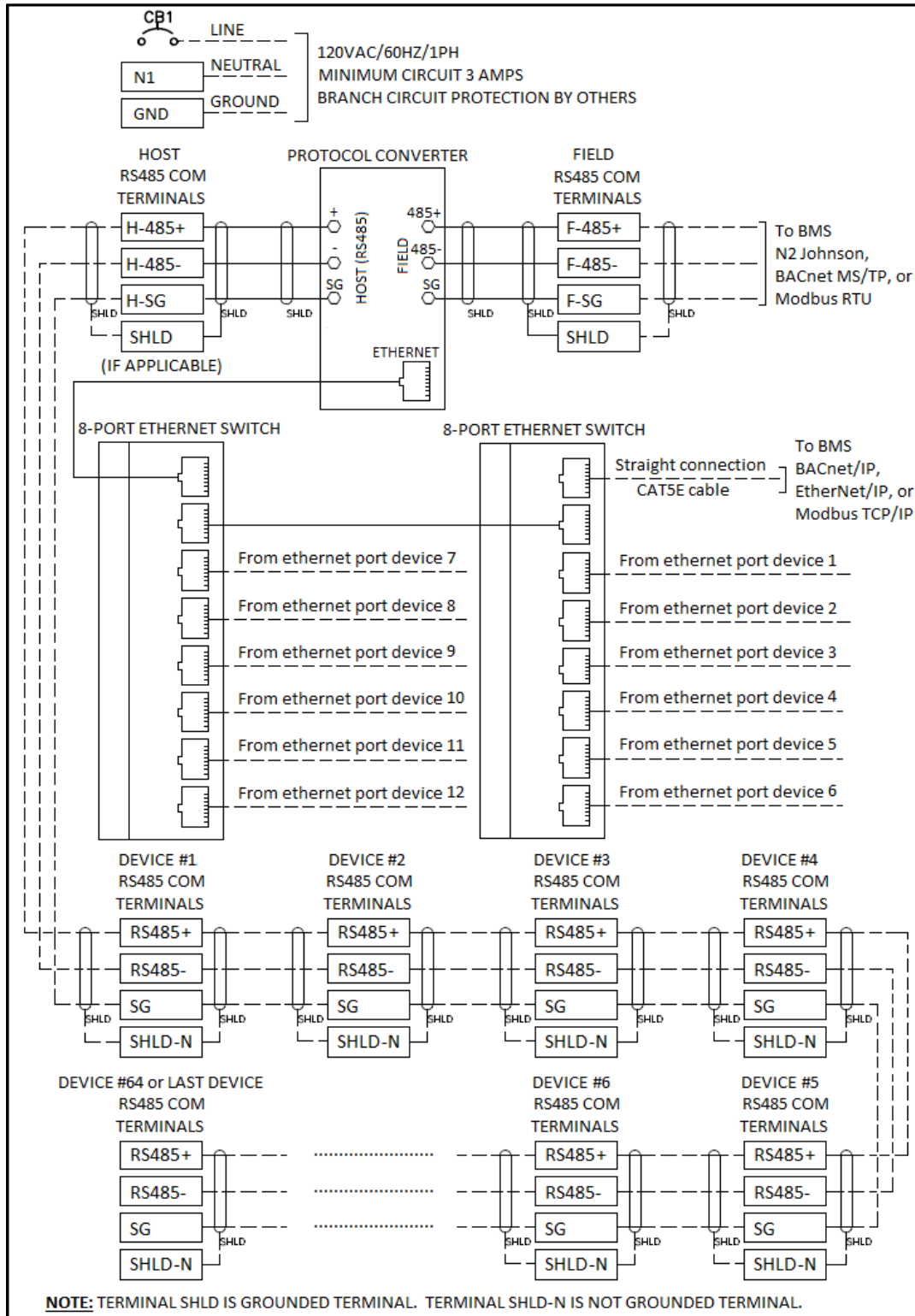

## Connections (continued)

(Host: Ethernet and Serial)

### ProtoAir TS-PX4-3-5 Port Ethernet Switch (BACnet/IP, BACnet MS/TP, Ethernet/IP, N2 Johnson, or Modbus RTU)

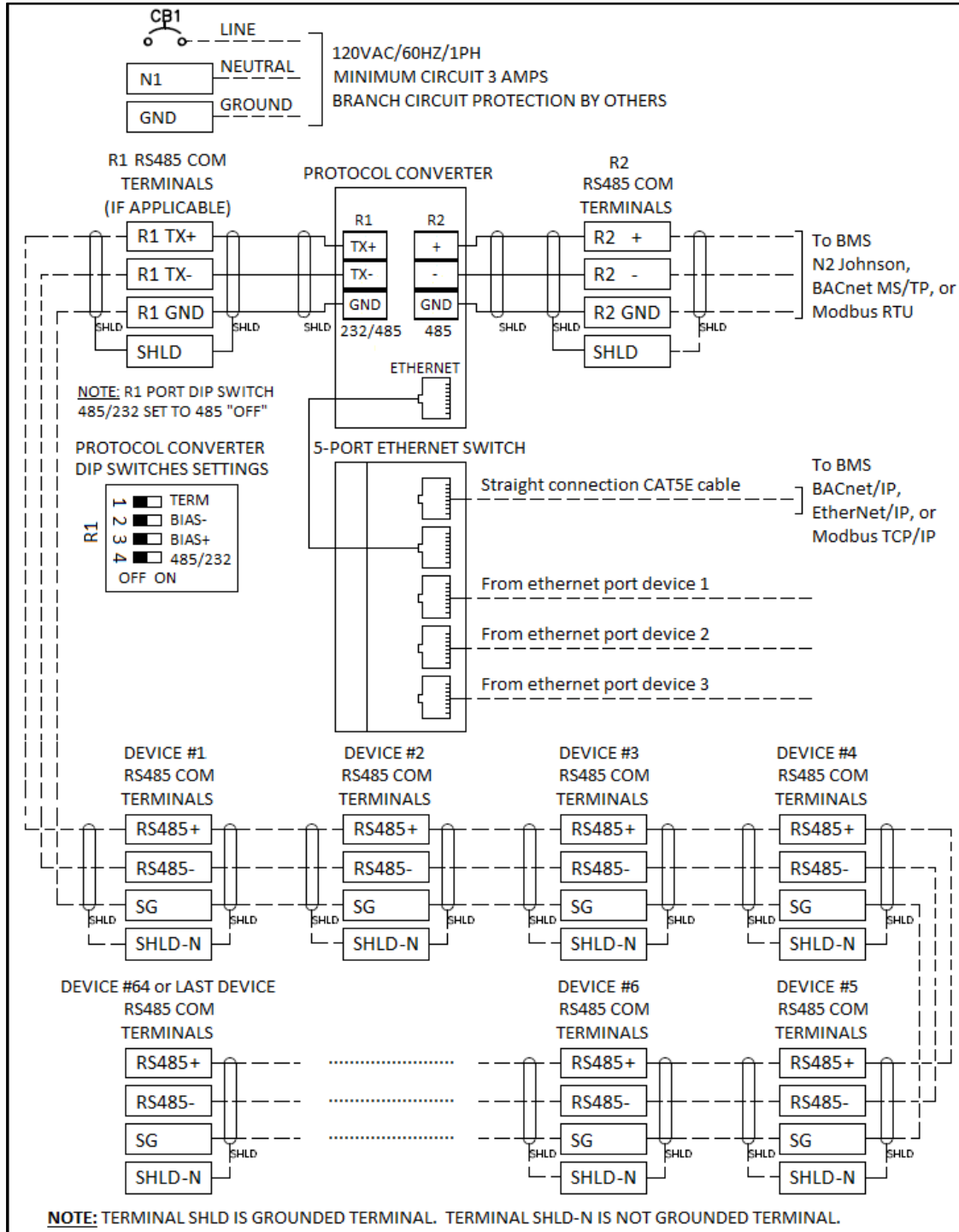

## Connections (continued)

ProtoAir TS-PX4-6-8 Port Ethernet Switch (BACnet/IP, BACnet MS/TP, Ethernet/IP, N2 Johnson, or Modbus RTU)

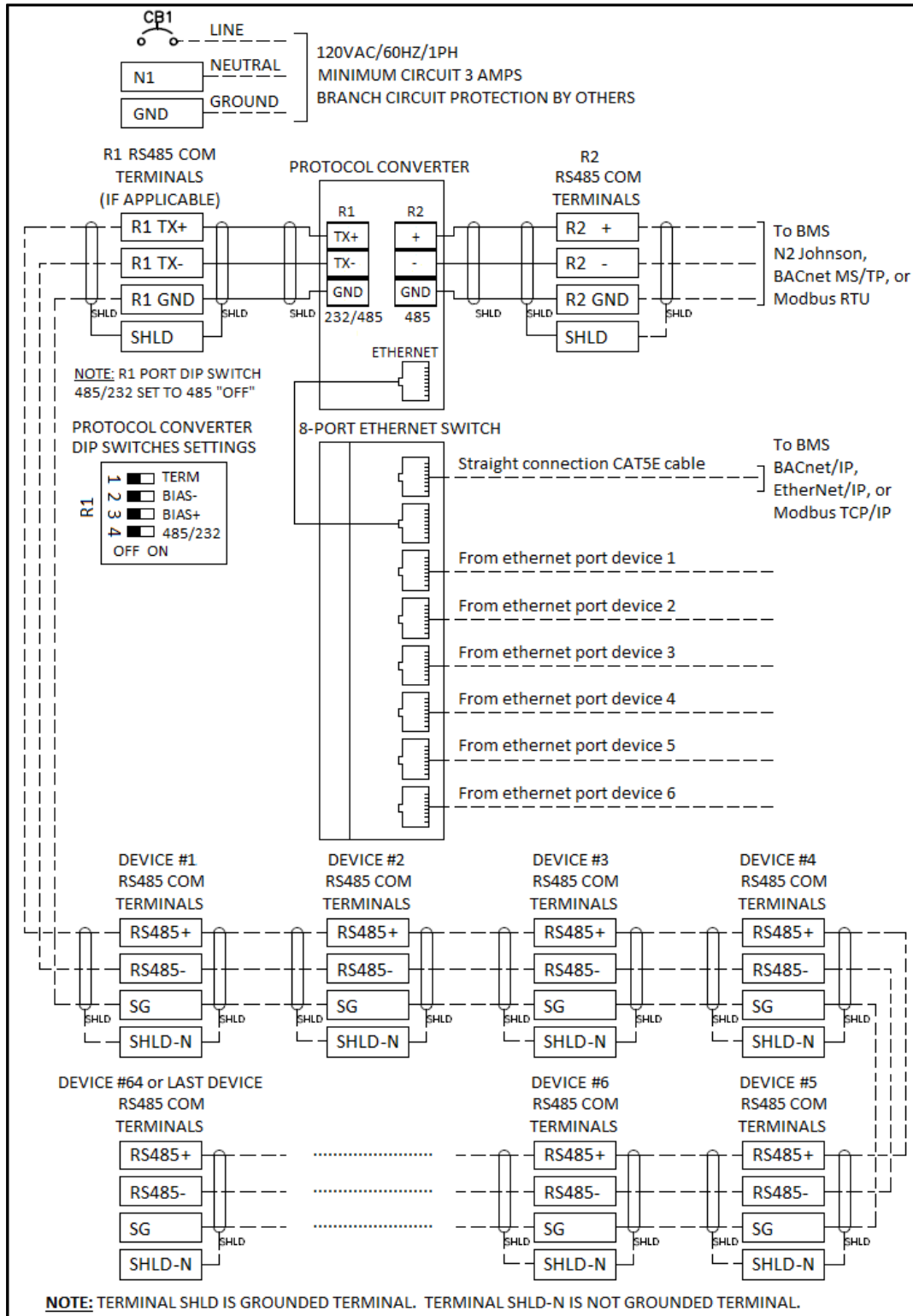

## Connections (continued)

ProtoAir TS-PX4-9-13 Port Ethernet Switch (BACnet/IP, BACnet MS/TP, Ethernet/IP, N2 Johnson, or Modbus RTU)

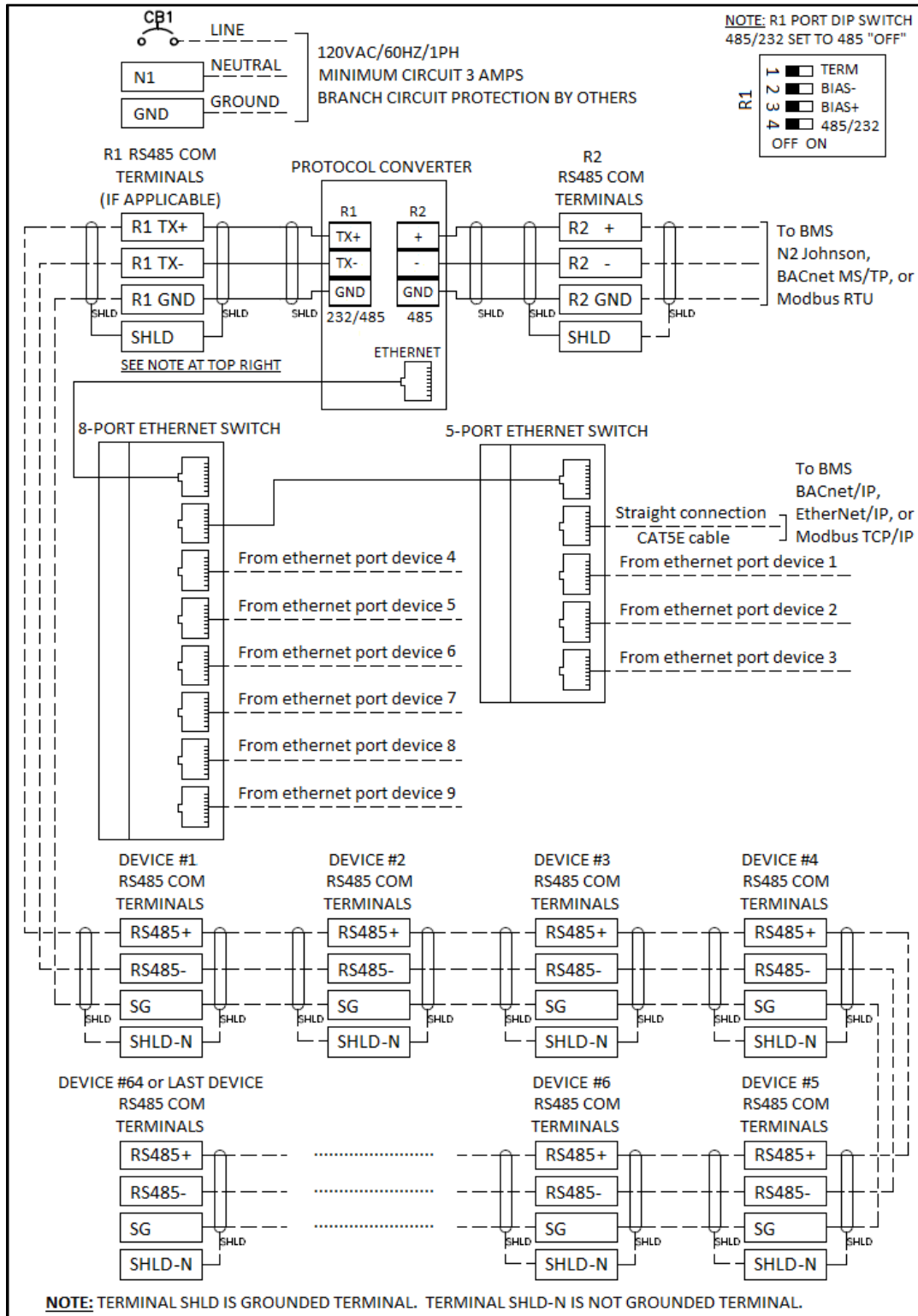

## Connections (continued)

ProtoAir TS-PX4-12-16 Port Ethernet Switch (BACnet/IP, BACnet MS/TP, Ethernet/IP, N2 Johnson, or Modbus RTU)

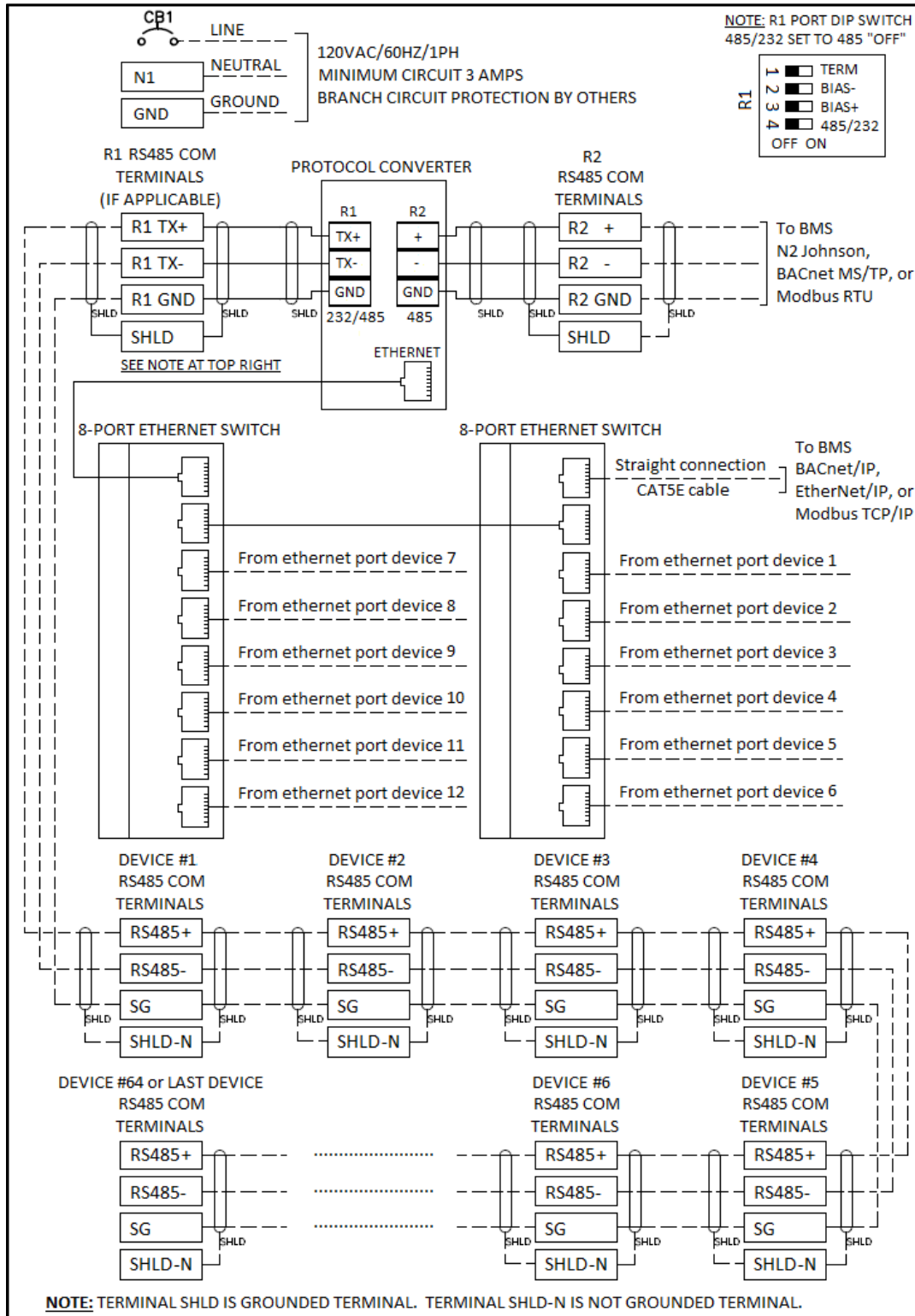

## Connections (continued)

### TS-PL4-3-5 Port Ethernet Switch (LonWorks)

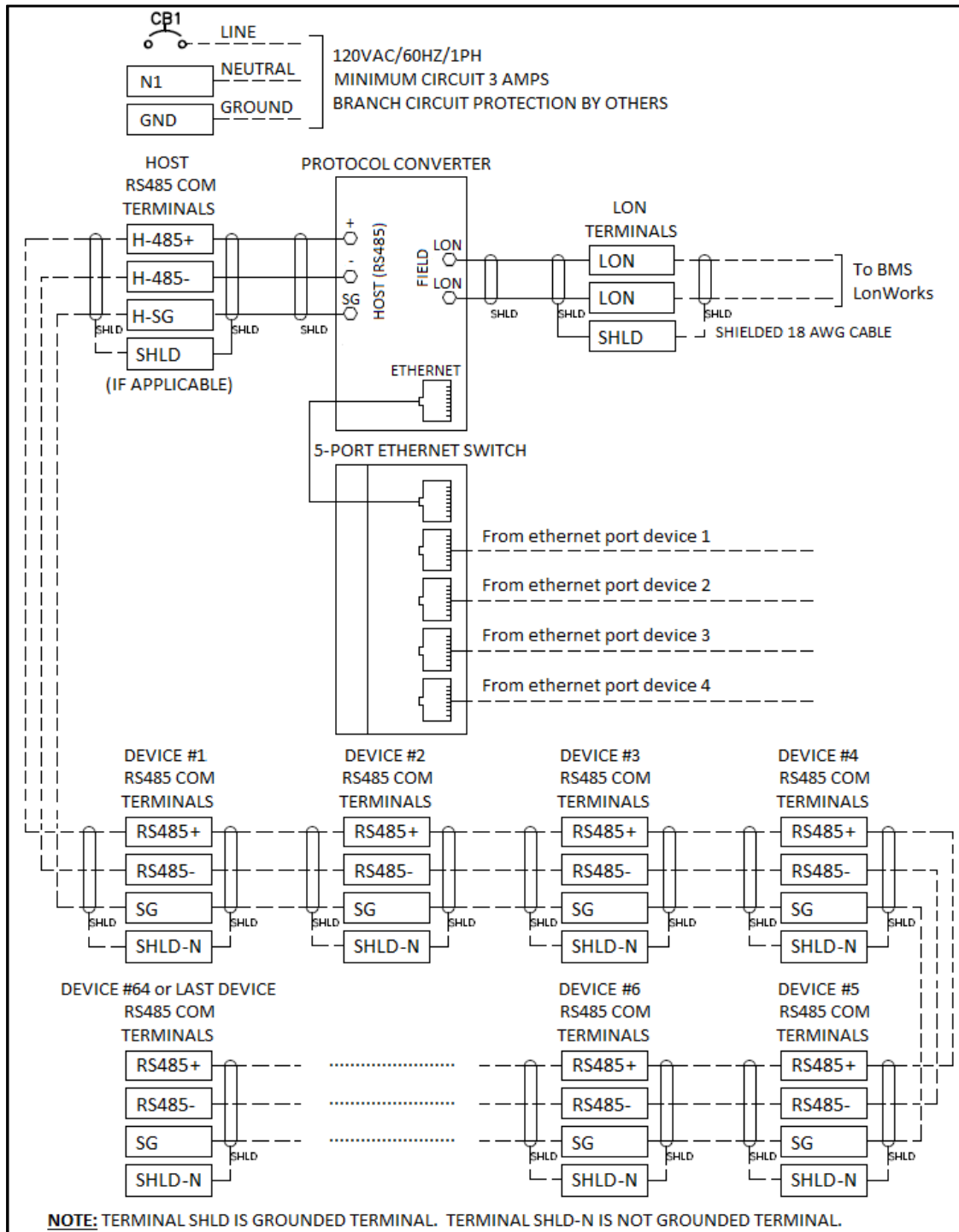

## Connections (continued)

### TS-PL4-6-8 Port Ethernet Switch (LonWorks)

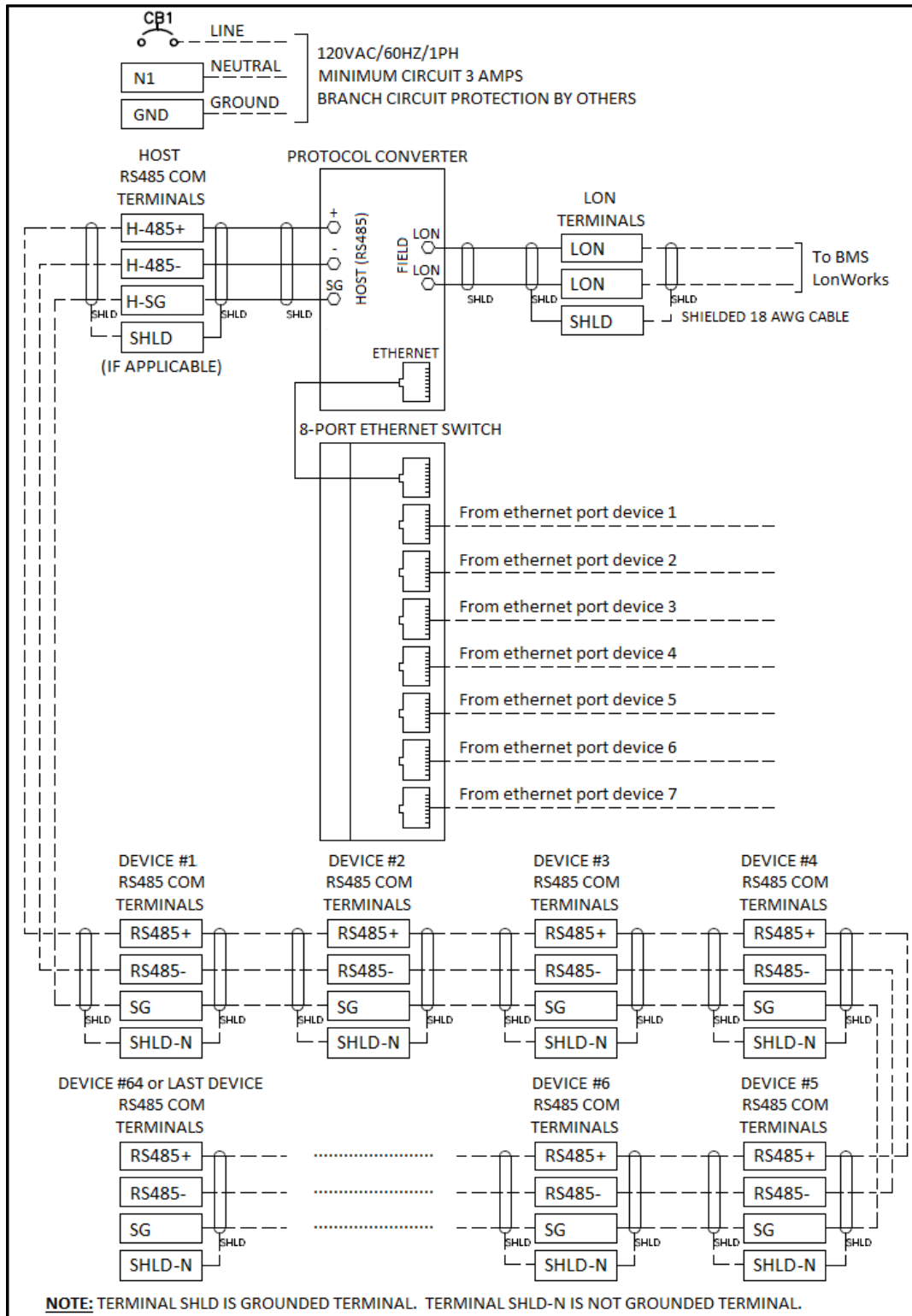

# Connections (continued)

## TS-PL4-9-13 Port Ethernet Switch (LonWorks)

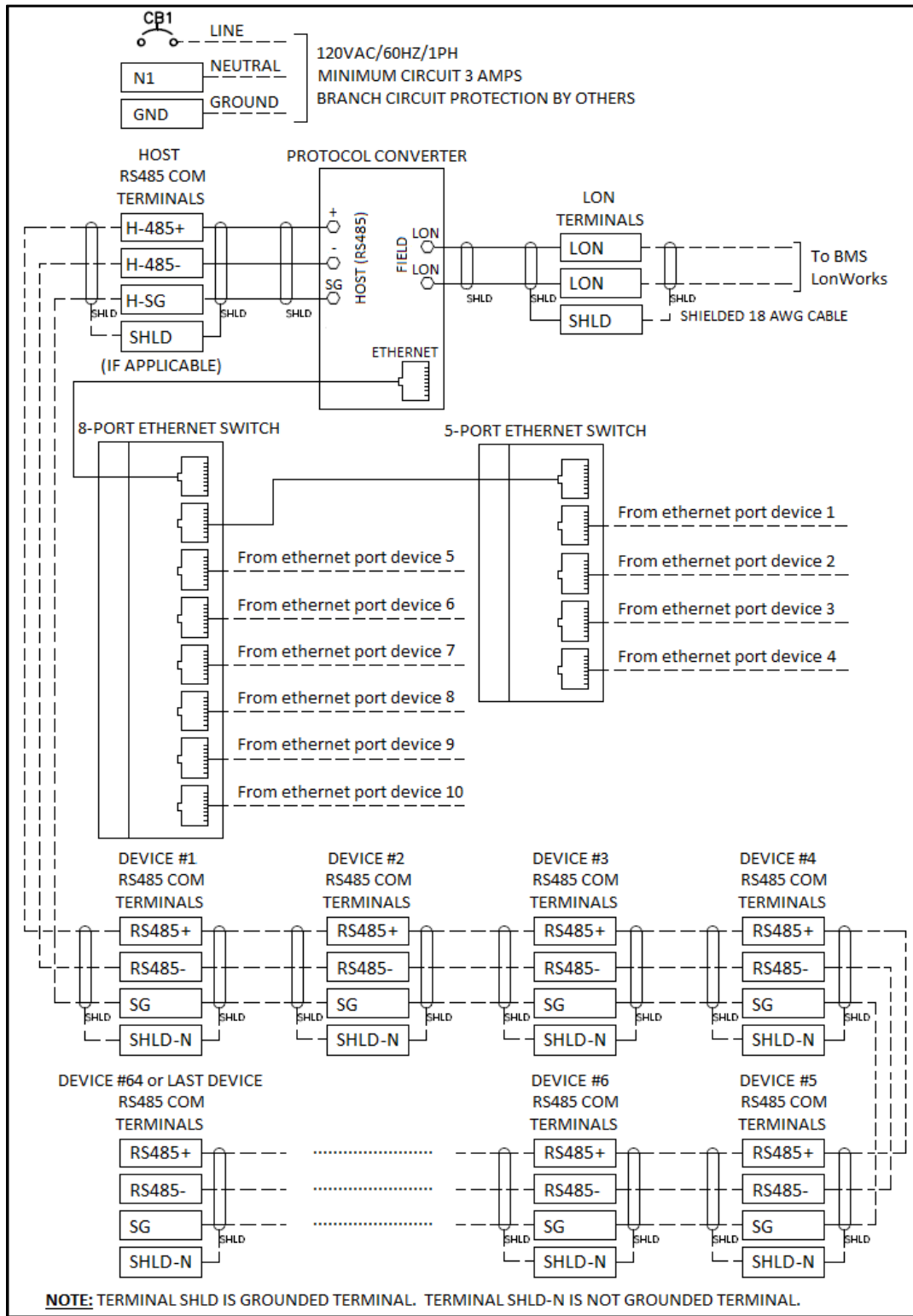

## Connections (continued)

### TS-PL4-12-16 Port Ethernet Switch (LonWorks)

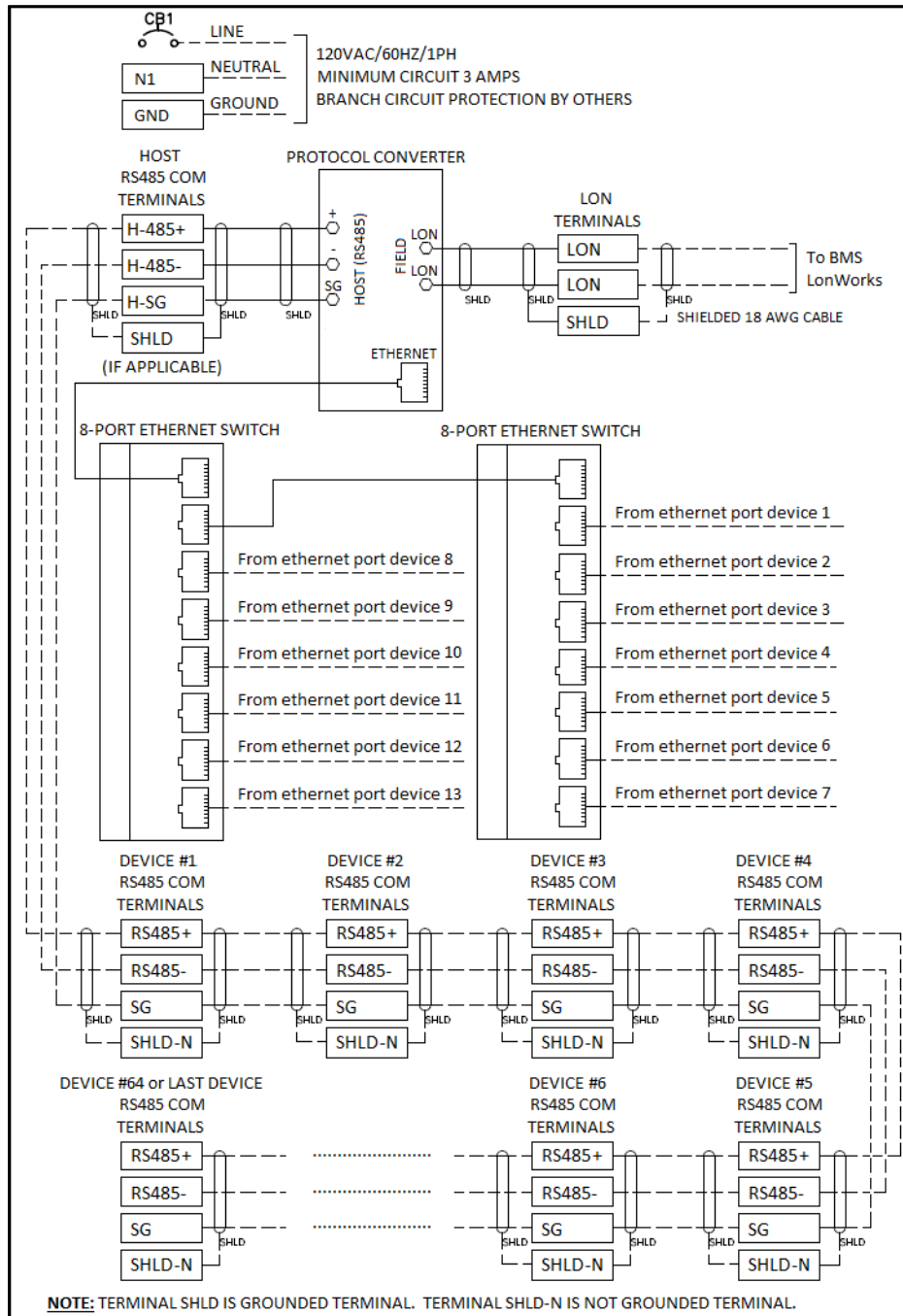

Information in this publication is based on current specifications. The company reserves the right to make changes in specifications and models as design improvements are introduced. Product or company names mentioned herein may be the trademarks of their respective owners. © 2009 SCC Inc.