

TS Series

TS-MS... Master Panels for Boiler Management, Lead/Lag, and Building Management System Interface

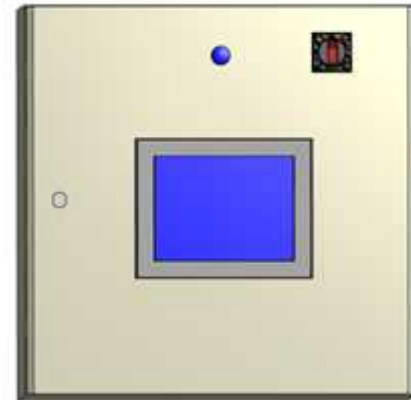

Description

A TS-MS... Series Master Lead/Lag Panel sequences and controls up to eight boilers equipped with TS... communication kits (see *Document No. TS-1000* or *Document No. TS-1050*) or TS... complete combustion control enclosures (see *Document No. TS-4000*).

A master panel controls hot water or steam boilers with Siemens LMV series linkageless control systems. Each panel includes a 7.5", 10", or 12" touchscreen with a programmable logic controller (PLC).

Flexible communication interface options to the building management system (BMS) provide streamlined data collection, monitoring, and controls. Additional options include pump controls and programmable analog and digital outputs.

Table of Contents

Compatible Controls and Accessories.....	6
Controls.....	6
Accessories.....	6
Physical Connections.....	7
External Devices.....	8
Connection to LMV3.....	8
Connection to LMV5.....	9
Sequence of Operation.....	10
Hydronic.....	10
Steam.....	11
Logging In.....	12
Activation.....	14
System Setup.....	15
General Setup.....	15
Hydronic Setup Options.....	20
Steam Setup Options.....	20
Expanded Annunciator Setup.....	21
Input/Output Configuration.....	22
Analog Input Configuration.....	23
Monitored Outputs (Analog).....	25
RTD Input Configuration.....	26
Monitored Outputs (Digital).....	27
Conditions.....	27
Logic.....	28
Loop Control Configuration.....	30
Loop Control Modbus Setup.....	32
Assigning Inputs To System Variables.....	35
Header Connection Notes.....	36
Loop Sensor Notes.....	37
Custom Tags.....	38
Boiler Tags.....	38
Fuel Tags.....	38
Email.....	39
Shortcuts/Special Characters.....	40
Text Messages.....	41
Other Options.....	42
More Options.....	43
Modbus Stats RWF.....	44
IP Addresses.....	45
Reset to Default IP.....	45
Default IP Addresses.....	46

Boiler Control Network.....	46
BMS Network.....	46
Saved Images.....	47
System Overview.....	48
System Local-Off-Remote Flowchart.....	51
Navigation Shortcuts from Overview.....	52
Boilers 5-8.....	53
Forcing Screen Saver.....	53
Loop Control Overview.....	54
Hysteresis Option.....	54
Two Pumps Option.....	55
Boiler Overview.....	56
Hand-Off-Auto.....	58
Hand-Off-Auto Flowchart (Serial Connection).....	59
Hand-Off-Auto Flowchart (Touchscreen Kit).....	60
Boiler Available Status.....	61
LMV3x/RWF55 Open Limits Option.....	61
LMV5x/RWF55 Load Controller Option.....	61
Setpoints.....	62
Dual-fuel With Staged Oil.....	63
System Setpoints.....	63
Boiler Protection.....	64
Demand (PID).....	65
Firing Rate Restrictions.....	66
Positive Low-Fire Forcing.....	66
Negative Low-Fire Forcing.....	67
PID Tuning Notes.....	68
Override Mode.....	68
Lead Selection.....	69
Lead By Alternation.....	70
Lead By LMV Startups or LMV Hours.....	71
Resetting RWF55 Startups/Hours.....	71
Count Offset.....	71
Forced Lead.....	72
Lead Skip (W1, W2).....	72
Lead Rotation (W1, W2).....	72
Lag Start/Stop.....	73
Parallel Modulation.....	74
Output.....	74
Enables.....	74
Firing Rates.....	75
Example.....	75
Parallel PV Modulation.....	76

Output.....	76
Enables.....	76
Firing Rates.....	77
Example.....	77
Sequential Modulation.....	78
Output.....	78
Enables.....	78
Firing Rates.....	79
Example.....	79
Force Setpoint Control LMV5.....	79
Deaerator.....	80
Pumps/Valves.....	81
Outside Air Reset.....	83
Outside Air Reset Curve Example.....	84
Analog Inputs.....	85
Datalog/Trends.....	86
Trends.....	87
Datalog.....	88
Register Lookup.....	89
Using the Clipboard.....	90
User Values.....	91
Loading User Value Scripts.....	91
Alarms.....	93
Date/Time/Defaults.....	94
Setting Date/Time.....	94
System Settings.....	94
Restore Factory Defaults.....	95
Email Settings.....	96
Enable Schedule.....	97
Using External USB Drive.....	98
Saving Screen Captures.....	99
Changing Passwords.....	101
Gateway/BMS.....	103
Additional Options.....	104
Disable Watchdog Timer.....	104
Outside Air Temperature from BMS.....	104
Direct Control of Lead Boiler.....	104
Direct Control of Load Demand.....	105
Setting Options via TS Series Protocol Converter.....	105
Changing Serial Port Parameters.....	106
Serial Port Wiring Interface.....	108
Modbus Mapping.....	109
Gateway/BMS – Mapping (Global System Data).....	110

Remote Control Strategies.....	113
Gateway/BMS – Mapping (Boiler Data).....	114
Gateway/BMS – Mapping (Deaerator/Surge Tank Data).....	118
LMV Phases.....	121
LMV5 Lockout/Error Codes.....	122
LMV3 Error Codes.....	125
Sample Monitored Value Applications.....	128
Domestic Hot Water Priority.....	128
Procedure.....	128
Using Digital Input from Thermostat.....	128
Using Analog or RTD Input.....	128
Wiring.....	130
Time-Based Actions.....	131
Procedure.....	131
Wiring.....	132
Creating User Value Scripts.....	133
Purpose.....	133
Format.....	133
Syntax Summary.....	134
Example Scripts.....	140
LMV5 Configuration for Modbus (Serial Connection).....	141
LMV3 Configuration for Modbus (Serial Connection).....	142
RWF55 Configuration for Modbus (Serial Connection).....	143
RWF10 Configuration for Modbus (Serial Connection).....	144
Loading Software Updates.....	145
Preparing Media.....	145
Loading Files to Touchscreen.....	148
Loading Files to PLC.....	150
ACS800 Software.....	151
Device Control.....	152
Data Collection.....	153
System Configuration.....	155
Export Data.....	156
Starting From Command Line.....	157
Remote Monitoring via Android or iOS Devices.....	158
Change Log.....	159
Revision 18D1.....	159
Revision 18J1.....	160
Revision 18J2.....	160

Compatible Controls and Accessories

Controls

- LMV5... with internal load controller
- LMV5... with RWF55 external load controller
- LMV3... with RWF10 or RWF55 external load controller
- RWF55 as standalone load controller

Accessories

- Feedwater control via RWF55 (steam boilers only)
- Connection to certain variable speed drives (combustion air fan)

Physical Connections

The Lead/Lag Master connects to individual Touchscreen Kits via Ethernet.

The Lead/Lag Master can also communicate with the connected equipment directly via Modbus. Connect any RS-485 devices in a daisy-chain with termination at the end of the chain (typically a 120-Ohm resistor). The following addresses are required for the connected equipment:

Table 1: Required Addressing of Controllers (x = Boiler Number)

Device	Required Address	Communication Type
LMV3x (via OCI412.10 or OCI413.20)	x1	Modbus RTU (RS-485)
LMV5x	x1	Modbus RTU (RS-232)
RWF10 (for load control)	x2	Modbus RTU (RS-485)
RWF55 (for load control)	x2	Modbus RTU (RS-485)
RWF55 (for feedwater)	x3	Modbus RTU (RS-485)
Loop control pump 1	1	Modbus RTU (RS-485)
Loop control pump 2	2	Modbus RTU (RS-485)

For example, boiler 1 LMV would be address 11 and boiler 4 feedwater would be address 43.

Communication via Modbus must be set with the following values:

- 19200 baud
- 8 stop bits
- 1 data bit
- no parity

See the appendixes for Modbus configuration details for each device.

External Devices

Connection to LMV3...

External devices such as draft controls or combustion air dampers must be placed in the low gas pressure switch and/or high oil pressure switch limit.

Connect the signal to activate the external device to terminal X6-03.3.

For gas fuel trains, connect the proven limits in series with the low gas pressure switch to terminal X5-01.2.

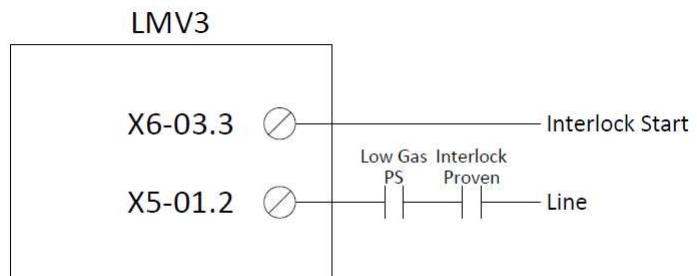

For oil fuel trains, connect the proven limits in series with the high oil pressure switch to terminal X5-02.2. For this feature to work, parameter 277 or 377 (High Oil PS) must be set to 1 (high oil pressure switch).

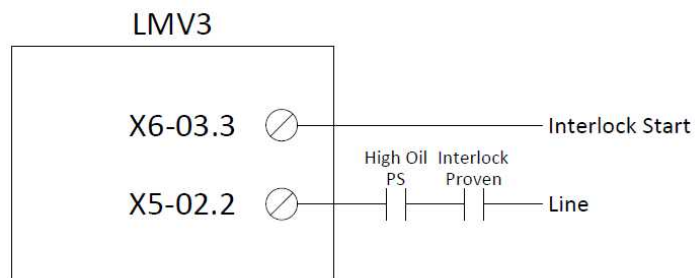

If the unit uses both fuels, wire relays to X5-03.2 (fuel 0 selected) and X5-03.3 (fuel 1 selected). These relays are necessary to prevent back feeding voltage and to bypass other gas options required to connect to X5-02.2 such as high gas pressure, POC or valve proving (shown as "Gas Option").

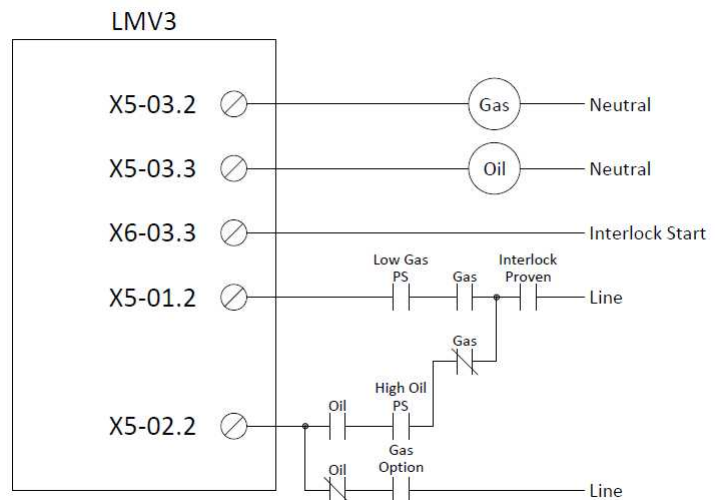

Set parameter 214 (Max Time Start Release) to a value long enough to ensure that the external device will prove open at every start. This parameter holds the LMV3... in phase 22 until terminal X5-01.2 or X5-02.2 has proven.

Note that using this method will result in lockout code 20 (low gas pressure switch) or 21 (high oil pressure switch) if the external device fails to prove.

External Devices (continued)

Connection to LMV5...

External devices such as draft controls or combustion air dampers must be placed in the start release circuit for gas and/or oil.

Connect the signal to activate the external device to terminal X4-03.3.

Connect line voltage through the proven limits to terminal X7-03.2 (gas) and/or terminal X6-01.1 (oil). Note that these terminals can both be connected simultaneously.

Set the start release time to a value long enough to ensure that the external device will prove open at every start. This parameter holds the LMV5... in phase 21 until the appropriate start release has proven.

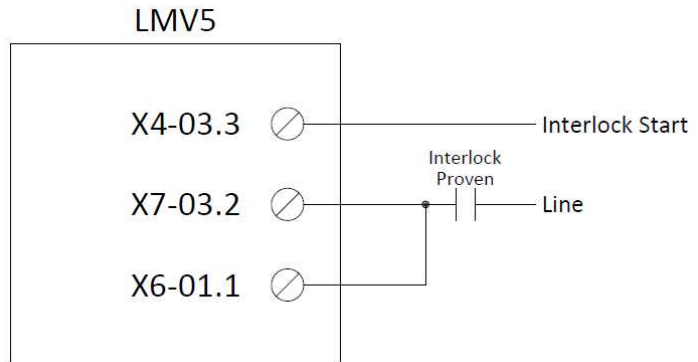

Set the following parameters:

- Params & Display > BurnerControl > Configuration > ConfigIn/Output > StartReleaseGas = **StartRelGas**
- Params & Display > BurnerControl > Configuration > ConfigIn/Output > StartReleaseOil = **activated**
- Params & Display > BurnerControl > Times > TimesGeneral > MaxTmeStartRel = **(allowable time for external limits to prove)**

Note that using this method will result in lockout code 47 (no start release gas) or lockout code 36 (no start release oil) if the external device fails to prove.

Sequence of Operation

Hydronic

When the system is enabled in Local or Remote mode, the PID will begin by comparing the setpoint against the controlling temperature sensor. This can be either the loop supply or loop return sensor. In Local the setpoint can be an Outside Air reset setpoint. The PID will generate a percentage demand. Once this demand is greater than zero, the lead boiler pump or valve will be commanded to run or open. Following the duration of the BOILER START DELAY parameter, the boiler will be commanded to fire. Once the lead boiler fires, it will hold at low fire for at least the duration of the MOD HOLD DELAY parameter. The firing rate is held at low fire until the temperature exceeds the LOW FIRE HOLD SP parameter, plus the duration of the MOD HOLD DELAY parameter. Once released to modulate, the lead boiler will fire at the PID demand percentage.

If the demand percentage exceeds the LAG START PERCENT completely for the duration of LAG START DELAY, the lag boiler pump or valve will be commanded to run or open. Following the duration of the BOILER START DELAY parameter, the lag boiler will be commanded to fire with the same low fire hold restrictions as described for the lead boiler. Once firing, the demand percentage will be divided among the firing boilers as prescribed by the selected modulation type. This procedure is repeated for each available lag boiler.

If the demand percentage drops below the LAG STOP PERCENT completely for the duration of LAG STOP DELAY, the lag boiler will be commanded off. The lag boiler pump or valve will continue to run or stay open for the duration of the PUMP OFF DELAY parameter. The demand percentage will then be redistributed equally among the remaining firing boilers.

If the criteria for the selected lead shutdown method are satisfied, the lead boiler will be commanded off. The lead boiler pump or valve will continue to run or stay open for the duration of the PUMP OFF DELAY parameter. The lead boiler and pump or valve will remain off or closed until the demand again is greater than zero.

If the temperature locally at any individual boiler exceeds the LOCAL SETPOINT parameter it will be tapered down for that individual boiler so that it does not trip the local limits. The rate of taper is linear based upon the LFH HIGH FORCE parameter.

When the lead boiler changes, the former lead will continue to follow the command intended for the lead boiler for an overlapping period. This is so that the new lead boiler has time to begin firing before the former lead boiler shuts down.

If the system is disabled by being placed in Off or remotely disabled while in Remote, the demand will drop to zero and the boilers will shut down in sequence. Once all the lag boilers have shut down the lead boiler will shut down as well.

Sequence of Operation (continued)

Steam

When the system is enabled in Local or Remote mode, the PID will begin by comparing the setpoint against the header pressure. The PID will generate a percentage demand. Once this demand is greater than zero, the lead boiler will be commanded to fire. Once the lead boiler fires, it will hold at low fire for at least the duration of the MOD HOLD DELAY parameter. If a shell temperature sensor is used, the firing rate is held at low fire until the temperature exceeds the LOW FIRE HOLD SP parameter, plus the duration of the MOD HOLD DELAY parameter. Once released to modulate, the lead boiler will fire at the PID demand percentage.

If the demand percentage exceeds the LAG START PERCENT completely for the duration of LAG START DELAY, the lag boiler pump will be commanded to run. Following the duration of the BOILER START DELAY parameter, the lag boiler will be commanded to fire with the same low fire hold restrictions as described for the lead boiler. Once firing, the demand percentage will be divided among the firing boilers as prescribed by the selected modulation type. This procedure is repeated for each available lag boiler.

If the demand percentage drops below the LAG STOP PERCENT completely for the duration of LAG STOP DELAY, the lag boiler will be commanded off. The lag boiler pump will continue to run for the duration of the PUMP OFF DELAY parameter. The demand percentage will then be redistributed equally among the remaining firing boilers.

If the criteria for the selected lead shutdown method are satisfied, the lead boiler will be commanded off. The lead boiler pump will continue to run for the duration of the PUMP OFF DELAY parameter. The lead boiler and pump will remain off until the demand again is greater than zero.

If the pressure locally at any individual boiler exceeds the LOCAL SETPOINT parameter it will be tapered down for that individual boiler so that it does not trip the local limits. The rate of taper is linear based upon the LFH HIGH FORCE parameter.

When the lead boiler changes, the former lead will continue to follow the command intended for the lead boiler for an overlapping period. This is so that the new lead boiler has time to begin firing before the former lead boiler shuts down.

If the system is disabled by being placed in Off or remotely disabled while in Remote, the demand will drop to zero and the boilers will shut down in sequence. Once all the lag boilers have shut down the lead boiler will shut down as well.

Logging In

When the Lead/Lag Master is powered up, the OVERVIEW screen will appear.

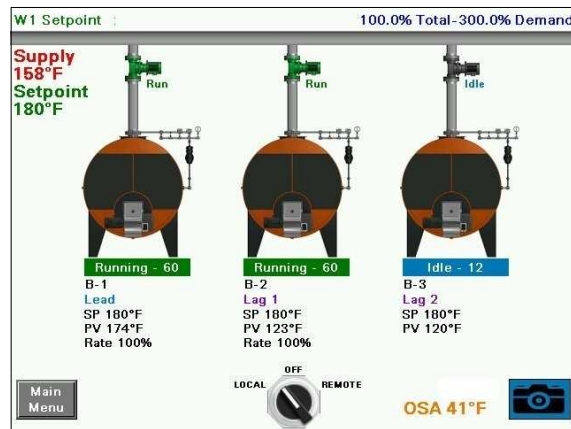

Press **MAIN MENU** in the lower left corner to go to the MAIN MENU screen.

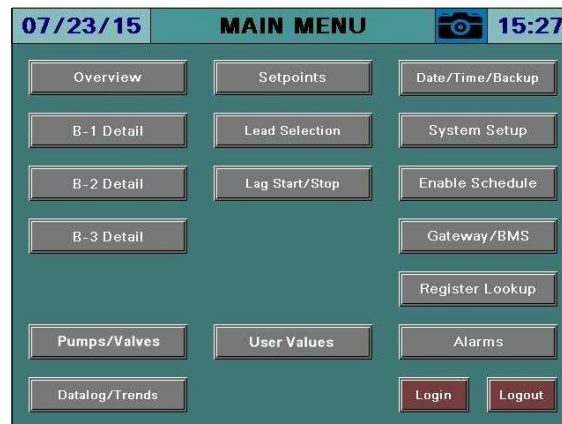

From here, different screens can be accessed depending on the access level. There are three access levels available:

- **USER:** Allows access to viewing data, changing setpoints, and manual operation. No username or password required.
- **TECH:** Same access as USER level as well as access to changing operational parameters. Username and password required. The username is TECH. The default password is 9876.
- **SETUP:** Same access as TECH level as well as access to programming touchscreen configuration settings. Username and password required. The username is SETUP. The default password is START.

The ACTIVATION screen may appear instead of the OVERVIEW screen following a software update.

Logging In (continued)

In order to log in at the desired access level, press **LOGIN**. The LOGIN screen will appear.

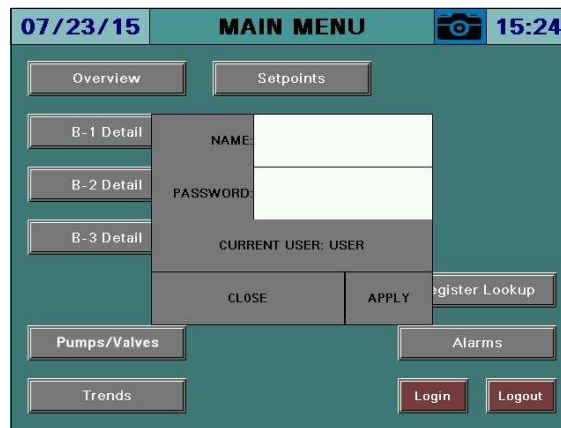

Tap the area next to NAME and a keypad will appear.

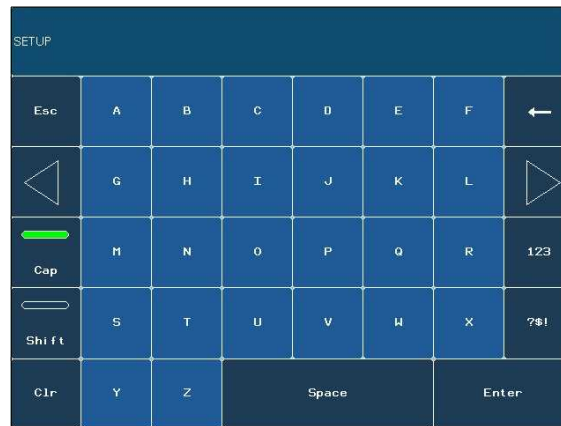

Use the keypad to enter the username for the desired access level. When finished, press **ENTER**.

Next, tap the area next to PASSWORD and the same keypad will appear again. Enter the password and then press **ENTER**.

When both the username and password have been entered, press **APPLY**. If successful, the CURRENT USER will change from USER to TECH or SETUP depending on the username and password that were entered. Press **CLOSE** to leave the login screen.

Activation

Software upgrades may require that an activation code is entered following the download. If the touchscreen is started without activation, the activation screen will appear. The touchscreen will automatically proceed to the SYSTEM SETUP screen for configuration once activated (see *System Setup* section for additional detail).

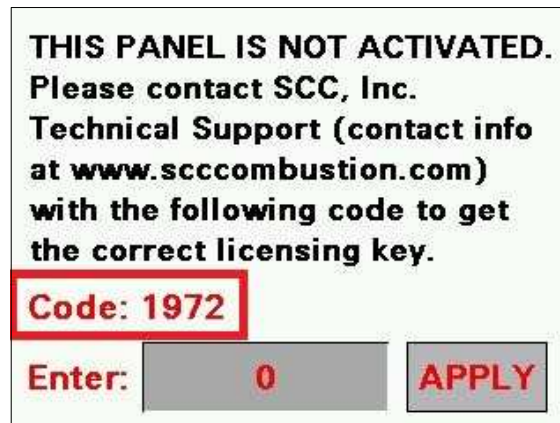

If the lead/lag controller is not activated, 'MASTER NOT ACTIVATED' will appear on the SYSTEM SETUP screen. Press **Master Activation** to enter the activation code.

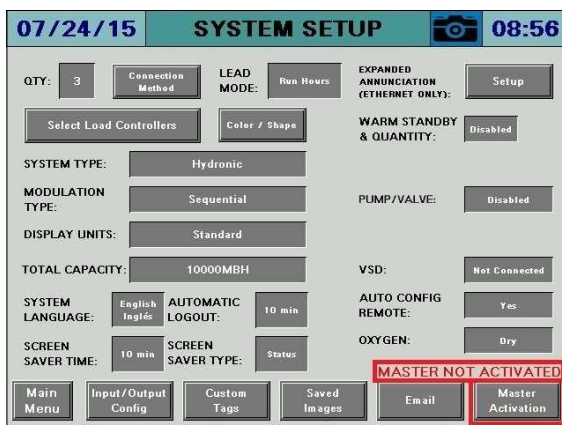

Contact SCC Inc. technical support with the code listed and an activation key will be provided. Once it is entered, press **APPLY**.

System Setup

Access level: **SETUP**

The Lead/Lag Master needs to be configured for the connected equipment. Press **SYSTEM SETUP** to display the SYSTEM SETUP screen.

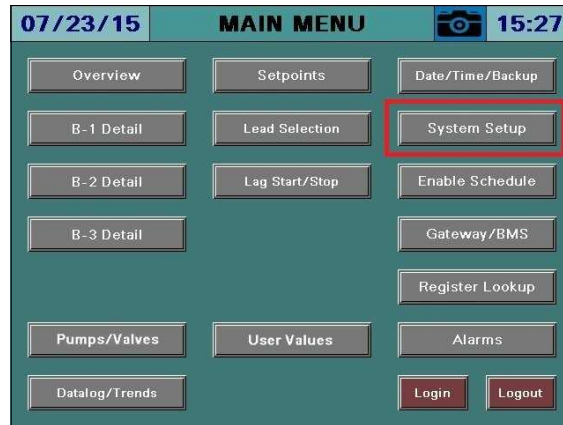

HYDRONIC

02/15/17		SYSTEM SETUP		02:56	
QTY: 3	Connection Method	LEAD MODE: Run Hours	EXPANDED ANNUNCIATION (ETHERNET ONLY): Setup		
Select Load Controllers	Color Shape	Burner	WARM STANDBY & QUANTITY: Disabled		
SYSTEM TYPE: Hydronic	MODULATION TYPE: Sequential		PUMP/VALVE: Disabled		
DISPLAY UNITS: Standard	TOTAL CAPACITY: 10000MBH		LMV3 ACTUATORS: None		
SYSTEM LANGUAGE: English	AUTOMATIC LOGOUT: 10 min	VSD: Not Connected	AUTO CONFIG REMOTE: Yes		
SCREEN SAVER TIME: 10 min	SCREEN SAVER TYPE: Status	OXYGEN: Dry			
Main Menu	Input/Output Config	Custom Tags	Email	Master Activation	>>>>

STEAM

02/15/17		SYSTEM SETUP		02:57	
QTY: 3	Connection Method	LEAD MODE: Run Hours	EXPANDED ANNUNCIATION (ETHERNET ONLY): Setup		
Select Load Controllers	Color Shape	Burner	WARM STANDBY & QUANTITY: Use Shell Temp 1		
SYSTEM TYPE: Steam	MODULATION TYPE: Parallel		FEEDWATER TYPE: RWFSG		
DISPLAY UNITS: Standard	TOTAL CAPACITY: 10000PPH		DEAERATOR: One		
SYSTEM LANGUAGE: English	AUTOMATIC LOGOUT: 10 min	VSD: Yaskawa	AUTO CONFIG REMOTE: Yes		
SCREEN SAVER TIME: 10 min	SCREEN SAVER TYPE: Status	OXYGEN: Dry			
Main Menu	Input/Output Config	Custom Tags	Email	Master Activation	>>>>

General Setup

QTY – Sets the total number of boilers connected to the system (1 to 8).

System Setup (continued)

CONNECTION METHOD – Displays a window used to select the connection method of each boiler.

- **Via Serial:** Select this option if the boiler is connected using serial communication.
- **Via Serial/Ethernet:** Select this option if the boiler is connected using serial communication through an Ethernet adapter.
- **Via Ethernet:** Select this option if the boiler has a Touchscreen Kit.

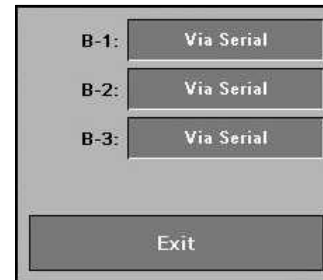

LEAD MODE – Selects the desired lead rotation method.

- **Run Hours** – Choose this option to alternate the lead boiler by elapsed run hours as counted by the Lead/Lag Master.
- **By LMV Startups** – Choose this option to alternate the lead boiler to obtain even LMV accumulated startup cycles. This is the best option when there is greater than one startup per hour and the desired outcome is to balance the LMV run time.
- **By LMV Hours** – Choose this option to alternate the lead boiler to obtain even LMV accumulated run hours. This is the best option when there is fewer than one startup per hour and the desired outcome is to balance the LMV run time.
- **Force Lead** – Choose this option to disable alternation.

System Setup (continued)

SELECT LOAD CONTROLLERS – Displays a window used to select which Siemens controller(s) are connected to the Lead/Lag Master. *Note that if an RWF... controller is mounted on the boiler or burner that it may actually be a feedwater controller. Do not select the RWF... as part of the load controller combination if it is a feedwater controller.*

- **LMV5x Only:** Select this option to connect a LMV5... and its internal load controller.
- **LMV5x/RWF55:** Select this option to connect a LMV5... with an RWF55 as an external load controller.
- **LMV3x Only:** Select this option to connect a LMV3... with no load controller.
- **LMV3x/RWF10:** Select this option to connect a LMV3... with an RWF10 as an external load controller.
- **LMV3x/RWF55:** Select this option to connect a LMV3... with an RWF55 as an external load controller.
- **RWF55 Only:** Select this option to connect an RWF55 load controller with no LMV... present (serial connections only).

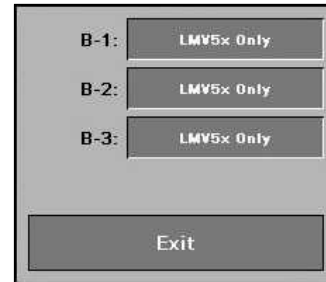

COLOR/SHAPE – Displays a window used to select the graphical image for each boiler.

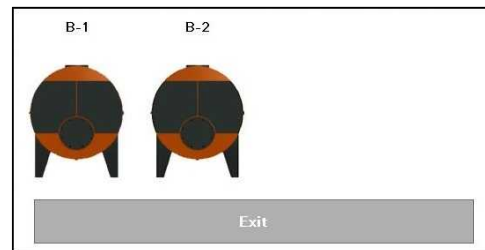

BURNER – Displays a window used to select the graphical image for each burner.

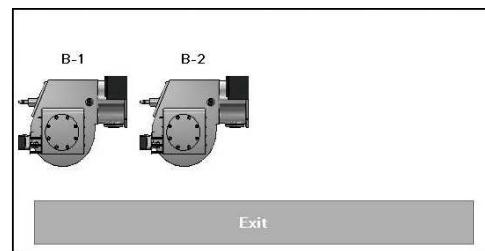

System Setup (continued)

SYSTEM TYPE – Selects the type of system that the Lead/Lag Master is controlling.

- **Steam**
- **Hydronic**

MODULATION TYPE – Selects the type of modulation that the Lead/Lag Master will use.

- **Parallel:** The firing rates of the boilers are based upon one central load demand and each running boiler will fire to that load demand. The start and stop points are based upon a percentage of this demand.
- **Sequential:** The firing rates of each boiler are based upon one central load demand and each new running boiler will begin modulating when the previous boiler has reached the base firing rate.
- **Parallel PV:** The firing rates of the boilers are based upon one central load demand and each running boiler will fire to that load demand. The start and stop points are based upon the process variable.

DISPLAY UNITS – Selects the type of units that the Lead/Lag Master will use. For steam boilers, the main unit will remain PSI but the temperature displays will follow this setting.

- **Metric**
- **Standard**

TOTAL CAPACITY – Sets the total MBH or PPH of the system. If a value is entered, a scaled estimate of the current output will be displayed based upon the load demand.

MASTER LANGUAGE – Selects the display language that the Lead/Lag Master will use.

- **English**
- **Spanish**

SCREEN SAVER – Select between off (no screen saver), 1m, 2m, 5m, 10m, 30m or 60m.

System Setup (continued)

SAVER TYPE – Select the screen saver type.

- **Status:** Shows the process variable, setpoint, and current status in a large font.
- **Blank:** Screen saver is a blank screen.

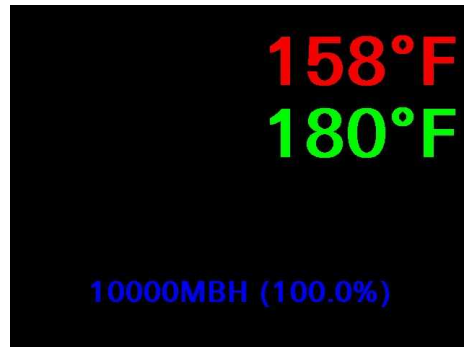

AUTO LOG OUT – Sets how long a user remains logged in. Select between 5m, 10m, 30m, 60m or 120m.

VSD – Select whether a compatible VSD system is installed on the combustion air fan. *The VSD must also be connected via Modbus to the connected Touchscreen Kits.*

- **Disabled**
- **Yaskawa:** Tested models are A1000 and V1000.
- **Danfoss:** Tested models are the FC Series.
- **PowerFlex:** Tested models are the PowerFlex 40 and PowerFlex 400.
- **ABB:** Tested models are the ACS550 and ACH550.
- **Delta:** Tested models are the C2000.

AUTO CONFIG REMOTE – Select whether configuration parameters are pushed to connected Touchscreen Kits. This does not apply to serial connected devices.

- **Yes:** Configuration at the Touchscreen Kits is locked out (use when universal configuration is present).
- **No:** Configuration must take place at the Touchscreen Kits individually (use when different configurations are desired by boiler).

O₂ – Select whether the O₂ and efficiency are calculated using the dry or wet method (only shows when LMV5 selected).

- **Dry:** The dry basis O₂ trim data (efficiency, O₂) is calculated from the wet basis O₂ trim data supplied by the LMV52. CO₂ and excess air are also calculated.
- **Wet:** The wet basis O₂ trim data (efficiency, O₂) is supplied by the LMV52.
- **Off:** The O₂ trim data display is disabled.

WARM STANDBY AND QUANTITY – Select whether warm standby is active, and for how many lag boilers to apply warm standby to.

- **Disabled**
- **Enabled**

System Setup (continued)

Hydronic Setup Options

PUMP/VALVE – Select how the boiler circulating pump or isolation valve is controlled.

- **Disabled**
- **Pump**
 - **Enabled:** The pump will be commanded on when the boiler is commanded on. The pump will remain on after the boiler command is removed for the duration of the off delay period.
 - **Lead Run Continuous:** The pump will be commanded on as long as the HAND-OFF-AUTO switch is not in OFF on the REMOTE OPERATION screen.
 - **Locally:** Select this option to command the pump from the Expanded Annunciator.
- **Valve**
 - **Enabled:** The valve will be commanded open when the boiler is commanded on. The valve will remain open after the boiler command is removed for the duration of the off delay period.
 - **Lead Run Continuous:** The valve will be commanded open as long as the HAND-OFF-AUTO switch is not in OFF on the REMOTE OPERATION screen.
 - **Locally:** Select this option to command the valve from the Expanded Annunciator.

Steam Setup Options

FEEDWATER – Choose whether a feedwater system is installed with a Siemens controller.

- **Disabled**
- **RWF55:** Select this option if the feedwater is being controlled by an RWF55.

DEAERATOR – Choose if a compatible SCC deaerator control panel is connected.

- **None**
- **One:** Select this option if a single panel is connected.
- **Two:** Select this option if two panels are connected.

System Setup (continued)

Expanded Annunciator Setup

EXPANDED ANNUNCIATOR SETUP – Displays a window used to enable the Expanded Annunciator and options in connected Touchscreen Kits.

- **EXPANDED ANNUNCIATOR:** Select whether the Expanded Annunciator option is present.
- **RTD CARD** – Select whether the RTD input option is enabled in the Expanded Annunciator (only shows up when EA optioned, requires RTD input option).
 - **Disabled**
 - **Enabled**
- **ANALOG CARD** – Select whether the analog input option is enabled in the Expanded Annunciator (only shows up when EA optioned, requires analog input option).
 - **Disabled**
 - **Enabled**
- **ECONOMIZER** – Select whether the economizer option is enabled in the Expanded Annunciator (only shows up when EA optioned, requires RTD input option or economizer RTD input option).
 - **Disabled**
 - **Enabled:** Uses economizer RTD input option for temperature sensors. The LMV5... stack temperature sensor may be used for one of the inputs.
 - **Use RTD:** Same as above, but uses the regular RTD input option for the economizer. Setting this option will automatically set the **RTD CARD option** to **Enabled**.
- **DRAFT CONTROL** – Select whether the draft control option is enabled in the Expanded Annunciator (only shows up when EA optioned, requires analog input option and RTD input option).
 - **Disabled**
 - **Enabled:** Uses three EA digital inputs for status.
- **EXTRA RWF** – Select whether additional RWF55 controls are connected serially via RS-485 to the Expanded Annunciator (only shows up when EA optioned, standard EA feature).
 - **None**
 - **1x RWF55:** Use Modbus address 1, 19200 baud, 8 stop bits, 1 data bit, no parity.
 - **2x RWF55:** Use Modbus addresses 1 & 2, 19200 baud, 8 stop bits, 1 data bit, no parity.

The screenshot shows a software window titled "Expanded Annunciator Setup". It contains several rows, each with a label on the left and a button on the right. The labels and their corresponding button states are: "EXPANDED ANNUNCIATOR:" with a "Connected" button; "RTD CARD:" with an "Enabled" button; "ANALOG CARD:" with an "Enabled" button; "ECONOMIZER:" with an "Enabled" button; "DRAFT CONTROL:" with an "Enabled" button; and "EXTRA RWF:" with a "Disabled" button. At the bottom of the window is a large "Exit" button.

Input/Output Configuration

Press **INPUT/OUTPUT CONFIG** to configure analog and digital inputs and outputs.

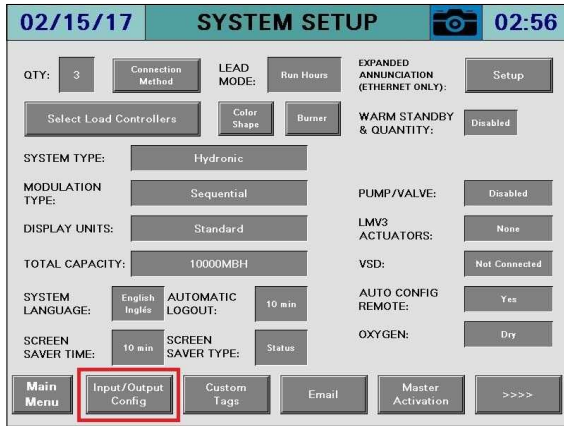

Input/Output Configuration (continued)

Analog Input Configuration

The screenshot shows a configuration screen for 'ANALOG INPUT 1'. The background is blue. At the top, the title 'ANALOG INPUT 1' is centered. Below it, there are several rows of configuration options, each with a label and a text box or button. The options are: NAME: Gas Flow (with a 'RESET TAG' button to its right), UNIT: CFH, TYPE: 4-20mA, FILTER: 0, MIN: 0, MAX: 10000, TOTALS: None, LOW: 0, HIGH: 0, and ALARM: None. At the bottom of the screen is a large 'Exit' button.

NAME – Sets the user-configured name for each input. The name may be up to 20 characters long. Press **RESET TAG** to clear the name and reset input configuration (requires > 1s press).

Once a name is entered, the input is activated and the remaining configuration information will appear.

UNIT – Sets the user-configured unit tag. The name may be up to 4 characters long.

TYPE – Select between 0-10V, 2-10V, 0-20mA, or 4-20mA.

FILTER – Sets the filter time used to average the incoming signal. This is useful when the signal is not steady (such as a draft sensor).

MIN, MAX – Sets the range of the input.

TOTALS – Sets the totalization for the input.

- **None**
- **Minute:** Totalization is calculated by the minute (such as gallons per minute).
- **Hour:** Totalization is calculated by the hour (such as gallons per hour).

Input/Output Configuration (continued)

LOW, HIGH – Sets the alarm setpoints for the input. When the input is below the low setpoint it generates a low alarm and when the input is above the high setpoint it generates a high alarm.

ALARM – Select the alarms generated by the input. Manual reset alarms may be reset by pressing **ALARM RESET** on the ALARMS page.

- **None**
- **Low Only:** Only an auto reset low alarm is generated.
- **LowMR:** Only a manual reset low alarm is generated.
- **High Only:** Only an auto reset high alarm is generated.
- **HighMR:** Only a manual reset high alarm is generated.
- **Low High:** Both an auto reset low alarm and auto reset high alarm are generated.
- **LowMR High:** Both a manual reset low alarm and auto reset high alarm are generated.
- **Low HighMR:** Both an auto reset low alarm and manual reset high alarm are generated.
- **LowMR HighMR:** Both a manual reset low alarm and manual reset high alarm are generated.

Input/Output Configuration (continued)

Monitored Outputs (Analog)

The monitored analog outputs can be configured to take an action based upon the value in any of the Modbus registers.

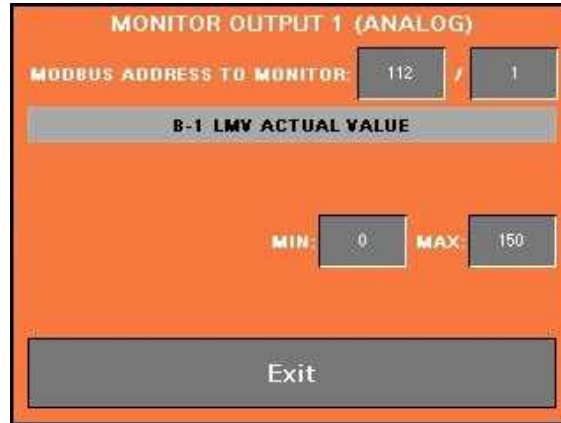

MODBUS ADDRESS TO MONITOR – Sets the Modbus register index to monitor and the divider to apply to it. The name of the chosen address will then be displayed.

MIN, MAX – Sets the scale for the analog output. If the actual value falls outside of the scaled range, the minimum or maximum value will be the output. For example, if address 112, 'B-1 LMV ACTUAL VALUE' is being monitored with a range of 0-150 (psi) and the actual is 160PSI, the output would be 100%. If it were 75PSI, the output would be 50%.

Input/Output Configuration (continued)

RTD Input Configuration

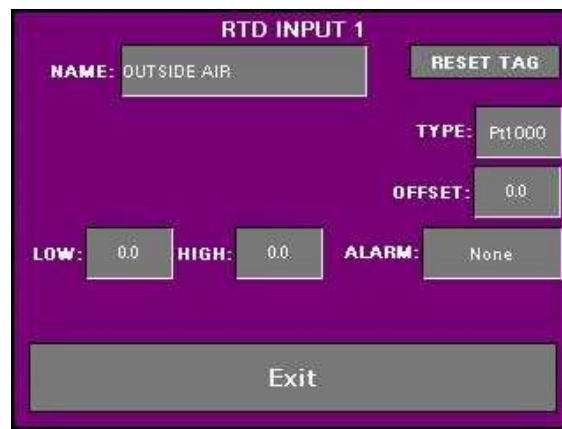

The screenshot shows a configuration screen for 'RTD INPUT 1'. The background is purple. At the top, the title 'RTD INPUT 1' is centered. Below the title, there are several fields and buttons: 'NAME: OUTSIDE AIR' (text input), 'RESET TAG' (button), 'TYPE: Pt1000' (text input), 'OFFSET: 0.0' (text input), 'LOW: 0.0' (text input), 'HIGH: 0.0' (text input), and 'ALARM: None' (text input). At the bottom, there is a large 'Exit' button.

NAME – Sets the user-configured name for each input. The name may be up to 20 characters long. Press **RESET TAG** to clear the name and reset input configuration (requires > 1s press).

Once a name is entered, the input is activated and the remaining configuration information will appear.

TYPE – Select between Pt1000 or LG-Ni1000.

OFFSET – Sets the offset in degrees applied to the input. This may be used to compensate for errors introduced by long wire runs.

LOW, HIGH – Sets the alarm setpoints for the input. When the input is below the low setpoint it generates a low alarm and when the input is above the high setpoint it generates a high alarm.

ALARM – Select the alarms generated by the input. Manual reset alarms may be reset by pressing **ALARM RESET** on the ALARMS page.

- **None**
- **Low Only:** Only an auto reset low alarm is generated.
- **LowMR:** Only a manual reset low alarm is generated.
- **High Only:** Only an auto reset high alarm is generated.
- **HighMR:** Only a manual reset high alarm is generated.
- **Low High:** Both an auto reset low alarm and auto reset high alarm are generated.
- **LowMR High:** Both a manual reset low alarm and auto reset high alarm are generated.
- **Low HighMR:** Both an auto reset low alarm and manual reset high alarm are generated.
- **LowMR HighMR:** Both a manual reset low alarm and manual reset high alarm are generated.

Input/Output Configuration (continued)

Monitored Outputs (Digital)

The monitored digital outputs can be configured to take an action based upon the value in any of the Modbus registers. Each monitored digital output can consider two conditions using a logical function. To enable or disable the second condition, touch the slider switch. See *Sample Monitored Value Applications* for additional detail.

Each monitored digital output can consider two conditions using a logical function.

Conditions

MODBUS ADDRESS TO MONITOR – Sets the Modbus register index to monitor and the divider to apply to it. The name of the chosen address will then be displayed.

WHEN – Select the logic applied to the value. Can be <, <=, >, >=, =, or a BIT comparison.

SETPOINT – Select the setpoint that the logic will be used to compare against. For bit comparisons, setpoint must be the specific bit of the word (0-15) for the result to be accurate.

Input/Output Configuration (continued)

Logic

CONDITION – Select whether the condition is normal or inverted.

- **CONDITION:** Will apply the result of the condition.
- **INVERTED CONDITION:** Will apply the opposite of the result of the condition.

LOGIC – Select the logic applied between the conditions.

- **AND:** Will apply AND gate (and) logic.



CONDITION 1	CONDITION 2	RESULT
FALSE	FALSE	FALSE
FALSE	TRUE	FALSE
TRUE	FALSE	FALSE
TRUE	TRUE	TRUE

- **OR:** Will apply OR gate (or) logic.



CONDITION 1	CONDITION 2	RESULT
FALSE	FALSE	FALSE
FALSE	TRUE	TRUE
TRUE	FALSE	TRUE
TRUE	TRUE	TRUE

- **NAND:** Will apply NAND gate (negative and) logic.



CONDITION 1	CONDITION 2	RESULT
FALSE	FALSE	TRUE
FALSE	TRUE	TRUE
TRUE	FALSE	TRUE
TRUE	TRUE	FALSE

- **NOR:** Will apply NOR gate (negative or) logic.



CONDITION 1	CONDITION 2	RESULT
FALSE	FALSE	TRUE
FALSE	TRUE	FALSE
TRUE	FALSE	FALSE
TRUE	TRUE	FALSE

- **XOR:** Will apply XOR gate (exclusive or) logic.



CONDITION 1	CONDITION 2	RESULT
FALSE	FALSE	FALSE
FALSE	TRUE	TRUE
TRUE	FALSE	TRUE
TRUE	TRUE	FALSE

- **XNOR:** Will apply XNOR gate (negative exclusive or) logic.



CONDITION 1	CONDITION 2	RESULT
FALSE	FALSE	TRUE
FALSE	TRUE	FALSE
TRUE	FALSE	FALSE
TRUE	TRUE	TRUE

Input/Output Configuration (continued)

APPLY – Select whether any delay is applied to the output.

- **NO DELAY:** Will turn the output on or off immediately.
- **DELAY ON:** Will turn the output on only after the specified delay.
- **DELAY OFF:** Will turn the output off only after the specified delay.

(DELAY TIME) OF – Sets the delay setpoint in seconds.

OPTIONS – Select the additional output options. Latched outputs may be reset by pressing **ALARM RESET** on the ALARMS page.

- **LATCH = NO, ALARM = NO:** Will not latch the output or generate an alarm with the output.
- **LATCH = YES, ALARM = NO:** Will latch the output but will not generate an alarm with the output.
- **LATCH = NO, ALARM = YES:** Will not latch the output but will generate an alarm with the output.
- **LATCH = YES, ALARM = YES:** Will latch the output and will generate an alarm with the output.

The current state of the logic is also displayed with true in green and false in red.

Input/Output Configuration (continued)

Loop Control Configuration

A loop control that can be used for controlling a valve, an auxiliary device or a set of two pumps can be activated. Depending upon the option chosen, different amounts of digital inputs and monitored outputs will be used as there are no dedicated outputs for these features. Setting one of the analog or RTD inputs as the loop control process variable by adding the text "E1" in the name will activate the loop control function (see *Assigning Inputs to System Variables* section for additional detail).

09/07/18 LOOP CONTROL SETUP 10:54

LOOP TYPE: Hysteresis

OUTPUT TYPE: Normal

LOOP NAME: Bldg. Pumps

PROPORTIONAL BAND: 5.0

INTEGRAL TIME: 320s

DERIVATIVE TIME: 0s

MINIMUM OUTPUT: 0

MAXIMUM OUTPUT: 100

HYSTERESIS ON: -5.0

HYSTERESIS OFF: 5.0

I/O Config

09/07/18 LOOP CONTROL SETUP 10:54

LOOP TYPE: Two Pumps Modbus

OUTPUT TYPE: Normal

LOOP NAME: Bldg. Pumps

PROPORTIONAL BAND: 5.0

INTEGRAL TIME: 320s

DERIVATIVE TIME: 0s

MINIMUM OUTPUT: 0

MAXIMUM OUTPUT: 100

SYSTEM OFF DELAY: 600s

PUMP ALARM: Enabled

PUMP ALARM DELAY: 30s

I/O Config

Modbus Setup

LOOP TYPE – Selects the type of loop control.

- **Disabled**
- **Valve:** The loop control will always modulate an analog output to control a setpoint. Uses monitored output 1 (analog) for the output signal.
- **Hysteresis:** Same as the valve option, but also controls a digital output to enable an auxiliary device. The output has an on and off hysteresis setpoint. Uses monitored output 1 (analog) and monitored output 3 (digital).
- **Two Pumps Wired:** The loop control will control two pumps with alternation and failure backup using wired connections. For steam applications, there is also a permissive that can be used for a limit such as a deaerator tank low water cut-off. Uses monitored output 1 (analog), monitored output 2 (analog), monitored output 3 (digital) and monitored output 4 (digital). It also uses digital inputs 1-5 for run status, alarm status and system permissive.
- **Two Pumps Modbus:** The loop control will control two pumps with alternation and failure backup using Modbus connections. For steam applications, there is also a permissive that can be used for a limit such as a deaerator tank low water cut-off. It also uses digital input 5 for system permissive.

Input/Output Configuration (continued)

OUTPUT TYPE – Selects how the output represents the loop output.

- **Normal:** The output matches the percent loop output.
- **Reversed:** The output reverses the percent loop output (0% loop output = 100% analog output and vice-versa).

LOOP NAME – Select the loop name to be shown on the overview screen and on alarm annunciations (up to 12 characters).

PROPORTIONAL BAND – Sets the proportional band for the loop control (see *Demand (PID)* section for additional detail).

INTEGRAL TIME – Sets the integral time for the loop control (see *Demand (PID)* section for additional detail).

DERIVATIVE TIME – Sets the derivative time for the loop control (see *Demand (PID)* section for additional detail).

MINIMUM OUTPUT – Sets the minimum PID output from 0% to 100%.

MAXIMUM OUTPUT – Sets the maximum PID output from 0% to 100%.

HYSTERESIS ON – Sets the on hysteresis for the loop control when the type is set for hysteresis control. For example, if the setpoint is 100 and the on hysteresis is -5, the on point would be 95. This applies when the output is off and the process variable is lowering. This can be a negative or positive number (hysteresis control mode only).

HYSTERESIS OFF – Sets the off hysteresis for the loop control when the type is set for hysteresis control. For example, if the setpoint is 100 and the off hysteresis is 5, the off point would be 105. This applies when the output is on and the process variable is rising. This can be a negative or positive number (hysteresis control mode only).

SYSTEM OFF DELAY – Sets the off delay time for the pumps to shut off when the system is disabled. If the lead boiler is set up to run continuously, the pumps will also stay enabled continuously (two pump control mode only).

PUMP ALARM – Selects whether timed pump alarms are generated when the pump does not prove operation (two pump control mode only).

- **Disabled**
- **Enabled**

PUMP ALARM DELAY – Sets the duration that the pumps have to prove before an alarm is generated (two pump control mode only).

Modbus Setup – Displays the Modbus setup screen.

Input/Output Configuration (continued)

Loop Control Modbus Setup

To use Modbus as the control method, the model of VSD used must support Modbus via RS-485 at 19200 baud, 8 data bits, 1 stop bit and no parity. The connections will be in a serial string (daisy-chain) with any other serial connected devices. The addresses used will be 1 for P-1 and 2 for P-2. The Modbus addresses for the status word, current (amps) and operating frequency (hertz) must be determined for reading, and the Modbus addresses for the control word and operating reference (hertz) must be determined for writing.

09/07/18		LOOP MODBUS SETUP				11:05	
READ BLOCKS:		1		WRITE BLOCKS:		2	
R1 ADDRESS:	0	R1 LENGTH:	16	W1 ADDRESS:	3	W1 LENGTH:	1
				W2 ADDRESS:	4	W2 LENGTH:	1
P1 NO COMMUNICATION P2 NO COMMUNICATION							
RUNNING	BLOCK:	R1	INDEX:	0	BIT:	0	CURRENT ON: 0.5 P1 IDLE P2 IDLE
ALARM	BLOCK:	R1	INDEX:	0	BIT:	1	P1 OK P2 OK
CURRENT	BLOCK:	R1	INDEX:	2	DIV:	/100	P1: 0.000A P2: 0.000A
FREQUENCY	BLOCK:	R1	INDEX:	15	DIV:	/10	P1: 0.000Hz P2: 0.000Hz
COMMAND	BLOCK:	W1	INDEX:	0	ON:	1151	OFF: 1150 P1: 1150 P2: 1151
REFERENCE	BLOCK:	W2	INDEX:	0	MIN:	0	MAX: 20000 6600
Previous							

READ BLOCKS – Selects how many read blocks are required to read the status word, current (amps) and operating frequency (hertz). The maximum allowed is three.

WRITE BLOCKS – Selects how many write blocks are required to write the control word and operating reference (hertz). The maximum allowed is two.

R1/R2/R3/W1/W2 ADDRESS – Selects the Modbus address for the selected block. This is zero-based (40001 = 0).

R1/R2/R3/W1/W2 LENGTH – Selects the length to read or write for the selected block. The maximum is 70.

P1/P2 COMMUNICATION – Displays the current status of Modbus communication to the specified device.

Input/Output Configuration (continued)

RUNNING – The specific source of data for the running condition is specified. This is normally part of the status word for the VSD.

- **BLOCK** – Specifies which read block the data is located in.
- **INDEX** – Specifies which index of the read the data is located in. For example, if the length of the block is 10, the valid indexes are 0-9. If the start was 0 (40001), this would mean index 0 is address 0 (40001), index 1 is address 1 (40002), ..., index 9 is address 9 (40010).
- **BIT** – Specifies which bit of the status word contains the running status. If **Current** is chosen, a setpoint based on the current (amps) will be used to determine the running condition.
- **CURRENT ON** – Specifies the setpoint used to determine the running condition. If the current (amps) indicated by the VSD exceeds this setpoint, the running condition is true.

ALARM – The specific source of data for the alarm condition is specified. This is normally part of the status word for the VSD.

- **BLOCK** – Specifies which read block the data is located in.
- **INDEX** – Specifies which index of the read the data is located in. For example, if the length of the block is 10, the valid indexes are 0-9. If the start was 0 (40001), this would mean index 0 is address 0 (40001), index 1 is address 1 (40002), ..., index 9 is address 9 (40010).
- **BIT** – Specifies which bit of the status word contains the alarm status. If **Timed Only** is chosen, only the timed alarm will be used.

CURRENT/FREQUENCY – The specific source of data for the current (amps) or operating frequency (hertz) is specified.

- **BLOCK** – Specifies which read block the data is located in.
- **INDEX** – Specifies which index of the read the data is located in. For example, if the length of the block is 10, the valid indexes are 0-9. If the start was 0 (40001), this would mean index 0 is address 0 (40001), index 1 is address 1 (40002), ..., index 9 is address 9 (40010).
- **DIV** – Specifies how the data read is divided to determine the actual value. For example, if 1.23 amps is represented in Modbus as "123", choose **/100** for the divider.

Input/Output Configuration (continued)

COMMAND – The specific location to send the control command is specified. This is normally part of the control word for the VSD.

- **BLOCK** – Specifies which write block the data is located in.
- **INDEX** – Specifies which index of the write the data is located in. For example, if the length of the block is 10, the valid indexes are 0-9. If the start was 0 (40001), this would mean index 0 is address 0 (40001), index 1 is address 1 (40002), ..., index 9 is address 9 (40010).
- **ON** – Specifies what word to write to operate the drive. This is determined by choosing the necessary bits to set. For example, if the control word bits to set for operation are "0000010001111111", "1151" is entered (the equivalent decimal value).
- **OFF** – Specifies what word to write to turn the drive while staying ready to run (idle). This is determined by choosing the necessary bits to set. For example, if the control word bits to set for idle are "0000010001111110", "1151" is entered (the equivalent decimal value). This will normally be one bit different than the **ON** word.

REFERENCE – The specific location to send the reference command (hertz) is specified.

- **BLOCK** – Specifies which write block the data is located in.
- **INDEX** – Specifies which index of the write the data is located in. For example, if the length of the block is 10, the valid indexes are 0-9. If the start was 0 (40001), this would mean index 0 is address 0 (40001), index 1 is address 1 (40002), ..., index 9 is address 9 (40010).
- **MIN** – Specifies the value to send for the minimum reference. For example, if the reference is required to be in the format 0-20000 for 0-60Hz, "0" is entered.
- **MAX** – Specifies the value to send for the maximum reference. For example, if the reference is required to be in the format 0-20000 for 0-60Hz, "20000" is entered.

Input/Output Configuration (continued)

Assigning Inputs To System Variables

Any of the analog inputs or RTD inputs can be assigned to the required system variables by assigning the proper name. The list of names (case-sensitive) and permitted inputs are shown in **Table 2**. When 'HEADERM' is entered for steam pressure in metric units, the unit used is millibars. This is abbreviated as 'mb'. The local process variable and setpoint of any connected LMV5... will be converted from bars with single-decimal accuracy to millibars for display on the overview and detail screens. The local process variable and setpoint of any connected RWF... should be configured for bars with single-decimal accuracy and will display as such on the overview and detail screens.

Table 2: System Variables

Name	Description	Inputs Allowed
REMOTE SETPOINT REMOTE SP	Remote analog setpoint.	AI1-4
HEADER	Steam system header pressure in standard units (process variable).	AI1-4
HEADERM	Steam system header pressure in metric units (process variable).	AI1-4
LOOP SUPPLY	Hydronic system loop supply temperature (default process variable).	AI1-4, RTD1-4
LOOP RETURN	Hydronic system loop return temperature.	AI1-4, RTD1-4
LOOP RETURN PV	Hydronic system loop return temperature (use as process variable).	AI1-4, RTD1-4
OUTSIDE AIR	Hydronic system outside air temperature, used for setpoint reset.	AI1-4, RTD1-4
E1 (includes)	Uses this input for the loop control process variable. Example: LOOP SUPPLY E1	AI1-4, RTD1-4
DT (includes)	Subtracts this input from the loop control process variable to create a delta variable. Example: LOOP RETURN DT (subtracts the loop return from the loop supply chosen above as E1)	AI1-4, RTD1-4

Input/Output Configuration (continued)

Header Connection Notes

Use a siphon (also known as a "pigtail") when connecting the header transmitter to the steam header. This reduces the temperature on the transmitter by introducing a water barrier between the live steam and the transmitter. Fill the siphon with water before connecting the transmitter.

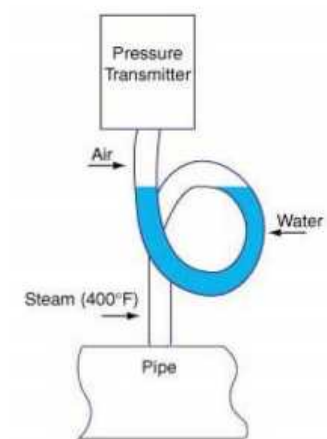

Input/Output Configuration (continued)

Loop Sensor Notes

The loop supply and loop return sensors should be placed in the building loop on both sides of the closely-spaced tees that connect the boiler loop. This is known as a "primary-secondary" arrangement. If there is only one loop, connect the sensors on both sides of where the boilers feed the loop.

If the sensors have been installed in the boiler loop, there is a setting to run the lead boiler pump continuously that must be used. This is important because there must always be flow across the sensors.

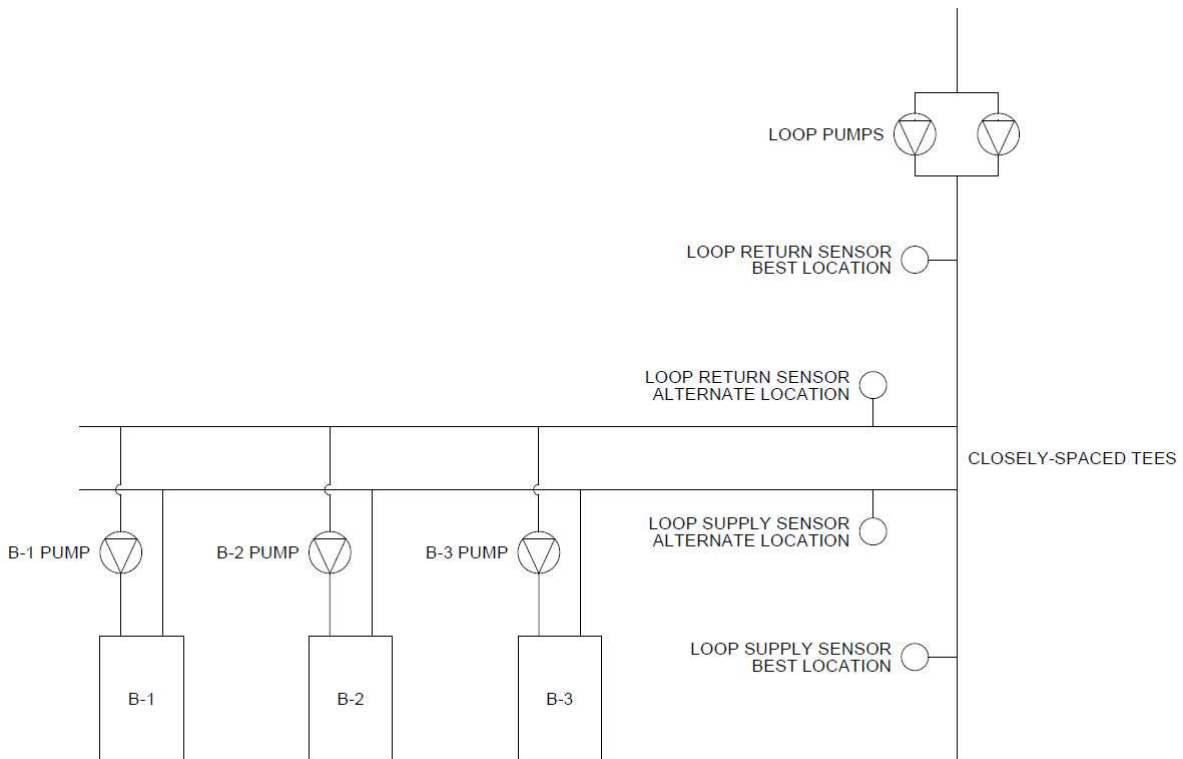

Custom Tags

Press **CUSTOM TAGS** to configure custom tags for the boilers and the fuels.

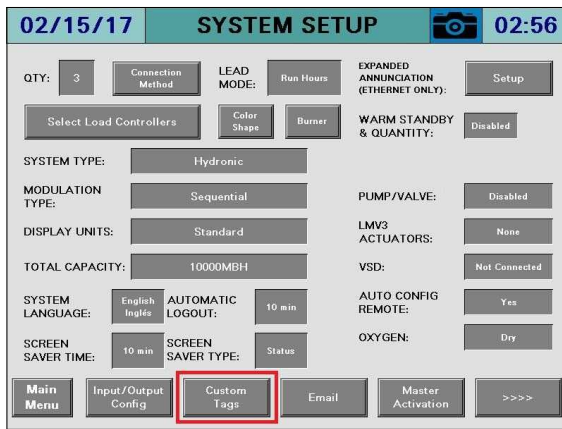

Boiler Tags

USE CUSTOM TAGS – Select whether to use custom or default tags.

BOILER x TAG – Sets the custom tag name for the boiler (up to six characters).

Fuel Tags

USE CUSTOM TAGS – Select whether to use custom or default tags.

FUEL x TAG – Sets the tag name for the fuel (up to six characters) and selects whether the fuel should represent a blue or an orange flame.

Email

Press **EMAIL** to configure email settings.

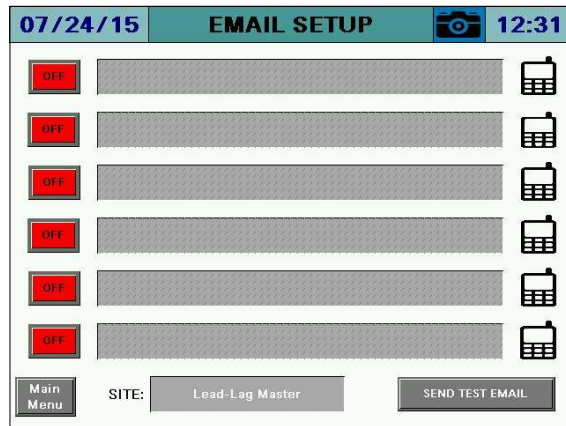
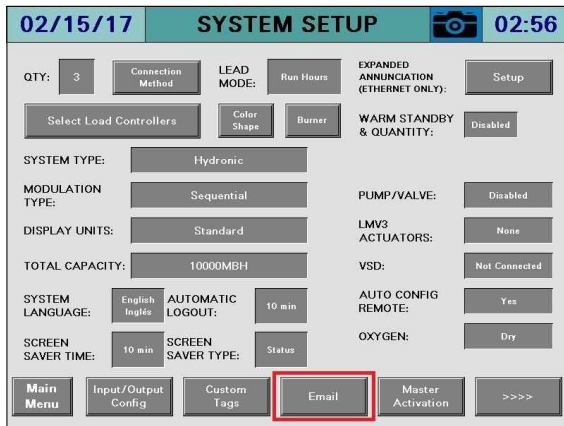

The touchscreen can be configured to send email to up to six addresses. This requires that the touchscreen is connected to a network with Internet access. Emails are sent automatically when alarms occur and may be sent manually to send screen captures and other data from the touchscreen. To configure an email address, press the **ON/OFF** button to the left of the address line, then enter the address.



Email (continued)

Shortcuts/Special Characters

Special character sequences can be used to generate commonly-used strings or characters that don't exist on the keyboard (such as an underscore). To use these, start with a space (" "), denoted in the example as **<sp>** or a backslash ("\") followed by one of the shortcut commands. End the shortcut with an additional space or backslash (unless it is the last command, then it is optional). The following shortcut commands are available:

- u = underscore (" _")
- d = dot (".")
- a = at (" @")
- h = hyphen (" -")
- c = .com
- e = .edu
- g = .gov
- o = .org
- on = 1
- tw = 2
- th = 3
- fo = 4
- fi = 5
- si = 6
- se = 7
- ei = 8
- ni = 9
- ze = 0
- gm = @gmail.com
- hm = @hotmail.com
- y = @yahoo.com
- ol = @outlook.com
- aol = @aol.com

The case of the text is not important. Uppercase characters will also work but the whole shortcut must be in one case (all lower or upper). Using these shortcuts makes it possible to type an entire email address without having to switch pages on the keyboard. For example, to type in example123@gmail.com using shortcuts, you'd type "example<sp>on<sp><sp>tw<sp><sp>th<sp><sp>gm". Notice that since each command requires a space both before and after, there are two spaces between each command. The space at the end is also omitted since it is the last command.

After the short version is entered the correct version will automatically replace it so it can be checked for accuracy.

Email (continued)

Text Messages

A template is provided to allow text messages to be sent via email. Press the phone icon on the right to bring up the template.

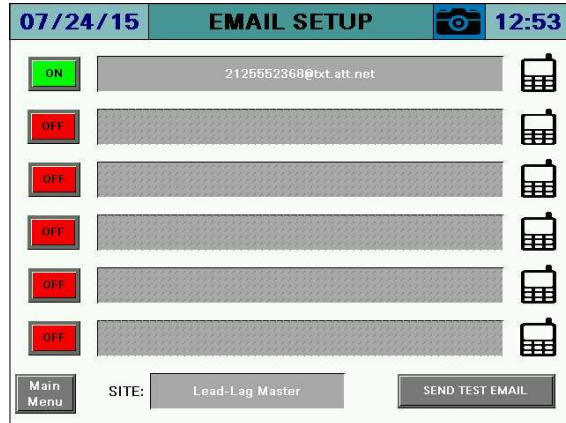
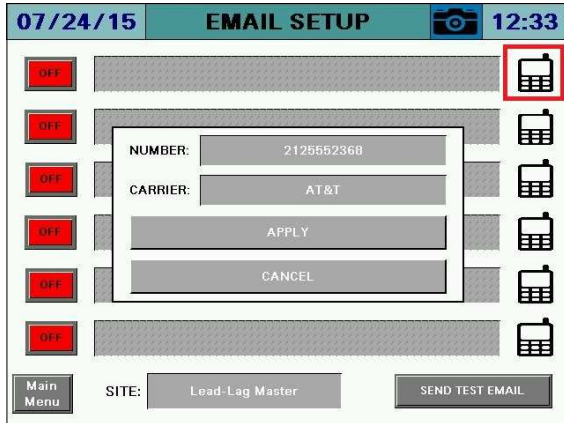

To check that the email addresses are valid and were entered correctly, press **SEND TEST EMAIL**.

Email (continued)

Other Options

Additional email options are available by pressing **EMAIL SETUP** for > 5s (hold down). This displays the EMAIL MANUAL screen.

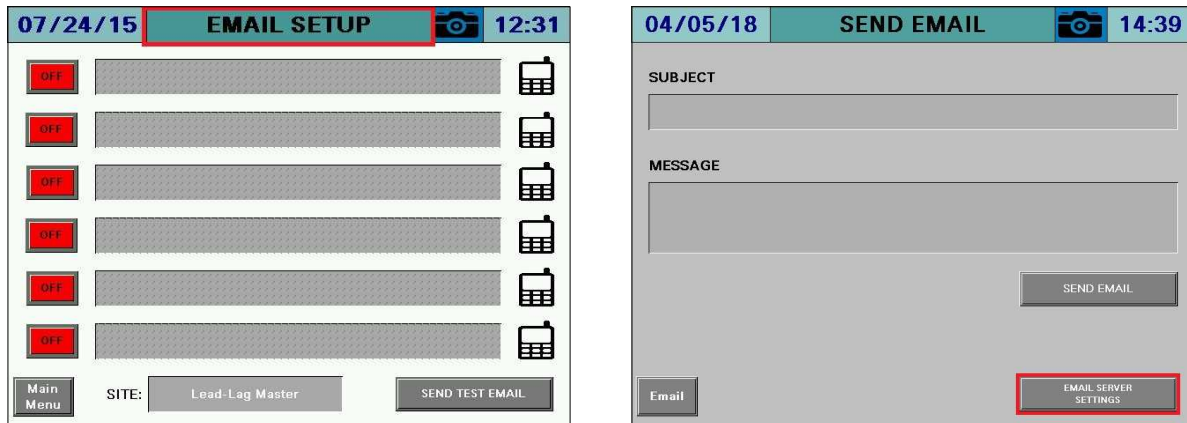

A custom email message can be sent from this screen. Enter a subject and a message (100 characters or less). Press **SEND EMAIL** to send the message.

Press **EMAIL SERVER SETTINGS** to display the EMAIL SERVER screen. The default email server settings can be changed if necessary. Press **RESTORE SCC DEFAULTS** to restore the server settings to the factory defaults. Note that if using the default settings, the return address cannot be changed or the mail server will reject the message.

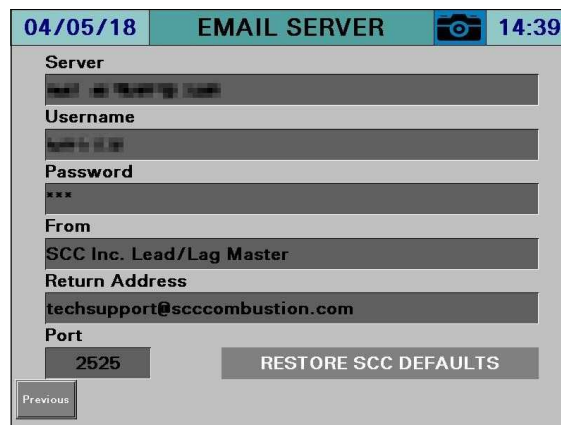

More Options

Press >>>> to display additional setup options and <<<< to return to initial options.

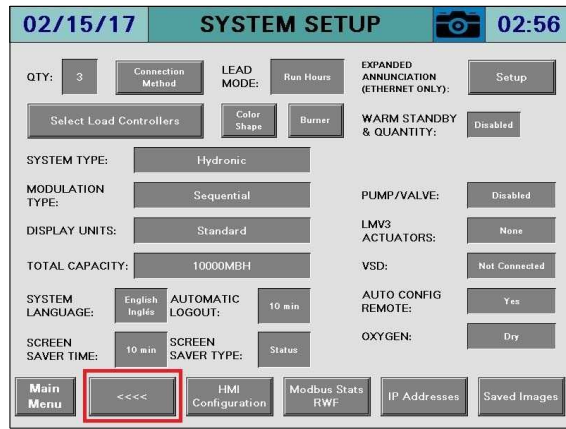
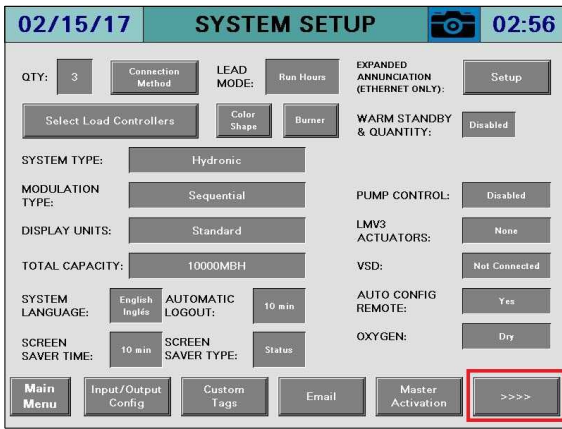

Modbus Stats RWF

Press **MODBUS STATS RWF** to display Modbus master settings and LMV5.../RWF55 load controller settings.

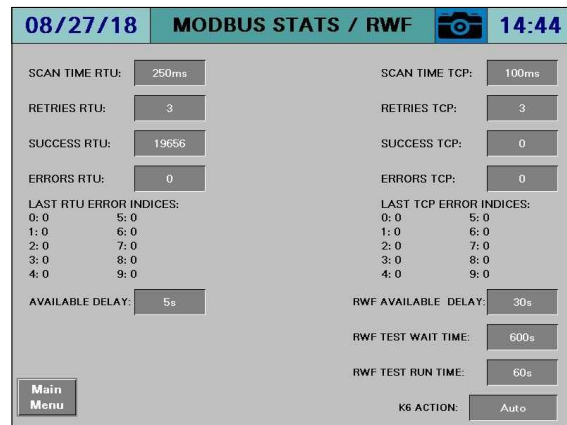
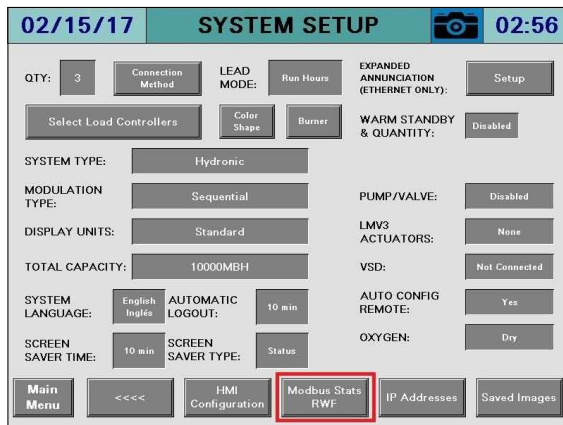

This allows adjustment to the Modbus master parameters for RTU and TCP as well as monitoring of the current communication statistics.

SCAN TIME RTU/TCP – Sets the delay between polls.

RETRIES RTU/TCP – Sets the number of retries when there is no response.

SUCCESS RTU/TCP – Displays successful communication statistics.

ERRORS RTU/TCP – Displays total communication error statistics. Touch to reset to zero (requires > 1s press).

LAST RTU/TCP ERROR INDICES – Diagnostic information on errors (internal SCC use).

AVAILABLE DELAY – Sets the delay before applying available status, used to filter any small interruptions to the signal.

RWF AVAILABLE DELAY – Sets the delay that the RWF must be enabled without the LMV5... showing the control switch input before the boiler is marked as unavailable.

RWF TEST WAIT TIME – When the boiler is marked as unavailable, it must be enabled periodically to update the available status. This parameter sets the interval between these enable cycles.

RWF TEST RUN TIME – When the boiler is marked as unavailable, it must be enabled periodically to update the available status. This parameter sets how long the boiler is enabled upon each test.

K6 ACTION – Sets the action of the K6 relay in auto.

- **Off**
- **On**
- **Auto** – The K6 relay command follows the enable command.

IP Addresses

Press **IP ADDRESSES** to display IP address settings.

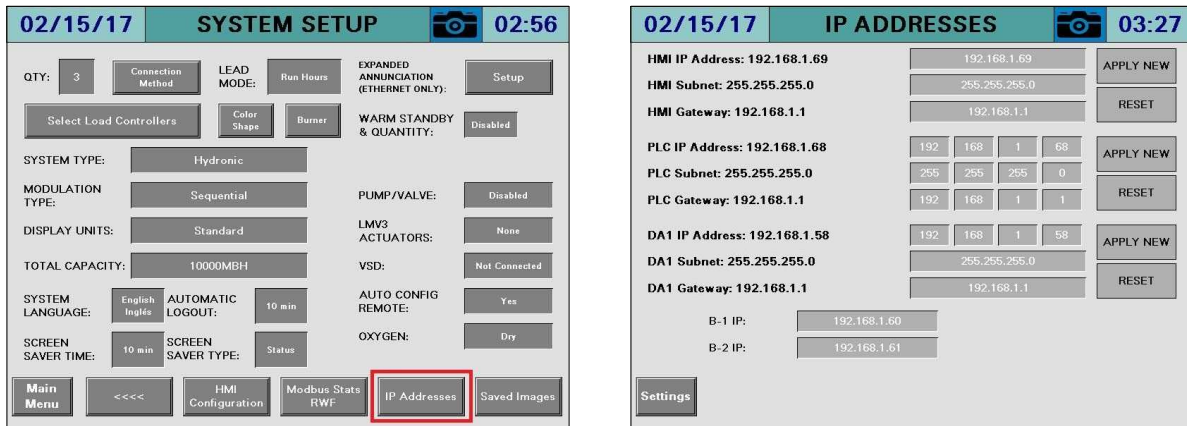

To toggle between the HMI (ETHERNET1) and BMS (ETHERNET2) IP addresses, touch the area marked **1** for > 1s (hold down). To toggle between the connected DA1 and DA2 IP addresses, touch the area marked **2** for > 1s.

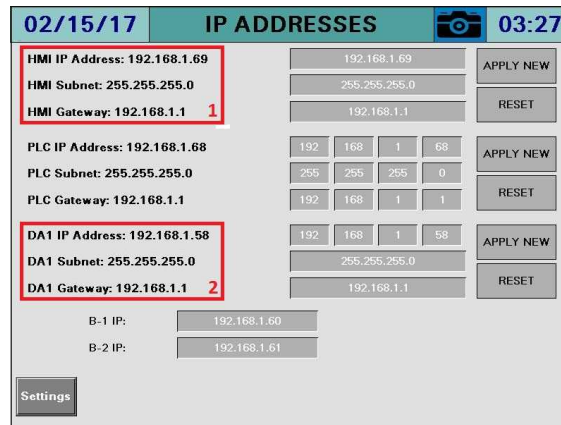

When changing the IP address for the HMI, BMS, PLC or either connected DA, touch **APPLY NEW** for > 1s (hold down) to apply the entered setting. Touch **RESET** for > 1s to return to the default IP address for that device. Changing the IP address for any touchscreen kit will take effect upon entry.

Reset to Default IP

If communication with the PLC cannot be established due to the IP address being unknown, it can be reset by applying 24VDC power to input **I20** for > 5s. This must be applied directly to the PLC terminal as this terminal is not connected to the terminal strip. The PLC will erase any stored IP (returning to the default), followed with a reboot. It may then be necessary to go to the IO Manager (see *Gateway/BMS* section for additional detail) to change the IP address of device **Master_PLC**.

Default IP Addresses

Boiler Control Network

The network between the Lead/Lag Master and the connected equipment requires specific static IP addresses to work properly. IP addresses on a network cannot be duplicated. These IP addresses should not be changed. A separate Ethernet port exists for BMS communication which can be programmed with a different IP address.

Lead/Lag Master HMI: 192.168.1.69
Lead/Lag Master PLC: 192.168.1.68
Boiler 1 Touchscreen Kit: 192.168.1.60
Boiler 2 Touchscreen Kit: 192.168.1.61
Boiler 3 Touchscreen Kit: 192.168.1.62
Boiler 4 Touchscreen Kit: 192.168.1.63
Boiler 5 Touchscreen Kit: 192.168.1.64
Boiler 6 Touchscreen Kit: 192.168.1.65
Boiler 7 Touchscreen Kit: 192.168.1.66
Boiler 8 Touchscreen Kit: 192.168.1.67
Deaerator/Surge 1: 192.168.1.58
Deaerator/Surge 2: 192.168.1.57
Protocol Converter: 192.168.1.70
Default Expanded Annunciator: 192.168.1.59
Boiler 1 Expanded Annunciator: 192.168.1.50
Boiler 2 Expanded Annunciator: 192.168.1.51
Boiler 3 Expanded Annunciator: 192.168.1.52
Boiler 4 Expanded Annunciator: 192.168.1.53
Boiler 5 Expanded Annunciator: 192.168.1.54
Boiler 6 Expanded Annunciator: 192.168.1.55
Boiler 7 Expanded Annunciator: 192.168.1.56
Boiler 8 Expanded Annunciator: 192.168.1.57
Subnet: 255.255.255.0
Default Gateway: 192.168.1.1

BMS Network

The BMS IP address can be changed as desired without causing any communication issues for the boiler control network. This port can also be used for remote viewing and email.

Lead/Lag Master BMS: 192.168.2.1
Subnet: 255.255.255.0
Default Gateway: 192.168.2.1

Saved Images

Press **SAVED IMAGES** to view screen captures stored on the USB drive. Images can be viewed and deleted as desired.

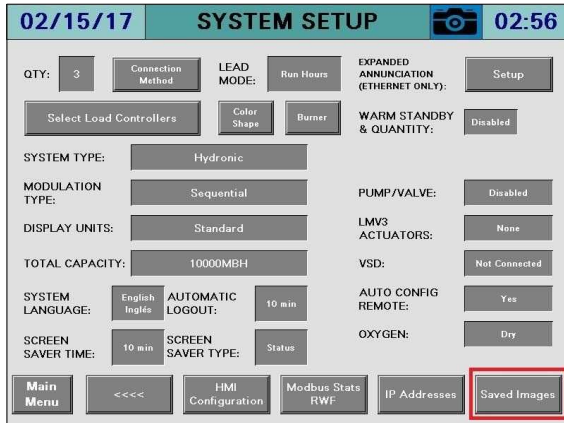

System Overview

Access level: **USER**

The system overview screen displays the real-time data for the boiler system. From the MAIN MENU screen, press **OVERVIEW**. The OVERVIEW screen will appear.



Only the parameters that are optioned and active are shown. Any others are hidden from the display for clarity. The following parameters may be shown on the overview screen (reference legend number for location on screen):

SETPOINT TYPE (1) – Displays the source of the current setpoint.

- **W1 Setpoint:** The system is using the W1 setpoint. Applies when the system is in LOCAL or is in REMOTE (with no remote setpoint present).
- **W2 Setpoint:** The system is using the W2 setpoint. Applies when the system is in LOCAL or is in REMOTE (system is not OFF). When activated, W2 overrides all other setpoints.
- **Remote Setpoint:** The system is using the remote setpoint. Applies when the system is in REMOTE (with a valid remote setpoint present).
- **OSA Setpoint:** The system is using the outside air reset setpoint (hydronic systems only). Applies when the system is in LOCAL and an outside air sensor is connected (with a valid signal).
- **W1 Setpoint (OSA Fault):** The system is using the W1 setpoint. Applies when the system is in LOCAL (with an invalid outside air sensor temperature).
- **System Disabled:** The system is commanded off. Applies when the system is in OFF or is in REMOTE (with a disable command).
- **Warm-Weather Shutdown:** The system is commanded off due to outside air temperature. Applies when the system is in LOCAL or is in REMOTE and an outside air temperature sensor is connected.

DEMAND (2) – Displays the capacity demand (0-100%), total throughput in MBH or PPH (if configured) as well as the system demand (0-100% per boiler additive, example three boilers = 300%).

System Overview (continued)

HEADER OR SUPPLY (3) – Displays the header pressure (steam systems) or loop supply temperature (hydronic systems).

RETURN (4) – Displays the loop return temperature, if equipped (hydronic systems).

SETPOINT (5) – Displays the current system setpoint as a pressure or temperature.

PUMP/VALVE STATUS (6) – Displays the pump status as running, fail or idle for the specific boiler when pump option is activated (hydronic systems only). If valve control is activated, the text "Valve Open" or "Valve Closed" (depending on the options) will display with no graphics.



STATUS BAR (7) – Displays the current phase description and number as well as the status (running, fail or idle) of the specific boiler.

- **RUNNING:** The status is displayed in green text, example **Running – 60**
- **FAIL:** The status is displayed in red text, example **Alarm – 0**
- **IDLE:** The status is displayed in blue text, example **Idle – 12**

BOILER TAG (8) – Displays the programmed boiler tag of the specific boiler.

LEAD/LAG STATUS (9) – Displays the current lead/lag status of the specific boiler.

- **Comm Fault:** The boiler is not communicating with the lead/lag master.
- **Lead:** The boiler is the lead boiler.
- **Lag 1-7:** The boiler is a lag boiler in the designated position.
- **Not Available:** The boiler is not available due to one of the following reasons (boiler control switch is off, boiler is not in automatic mode, boiler is in lockout, or boiler with LMV5... controller is not set for "IntLC Bus").

SP (10) – Displays the current setpoint of the specific boiler.

PV (11) – Displays the actual value of the specific boiler.

RATE (12) – Displays the firing rate in percent or number of stages active of the specific boiler.

OSA (13) – Displays the system outside air temperature, if equipped.

System Overview (continued)

SYSTEM LOCAL-OFF-REMOTE (14) – Sets the mode of the system.

- **LOCAL:** The system is enabled.
- **OFF:** The system is disabled.
- **REMOTE:** The system enable/disable is provided by remote system. Defaults to enabled if no remote system is connected.

There are two ways to change the position of the LOCAL-OFF-REMOTE switch. Touching the switch for > 1s (hold down) will toggle the switch to the next position. Touching the 'LOCAL', 'OFF' or 'REMOTE' text for > 1s will switch to that position directly.

LOOP CONTROL (15) – Changes to the loop control screen, if activated. The button will display the tag name of the loop control.

System Overview (continued)

System Local-Off-Remote Flowchart

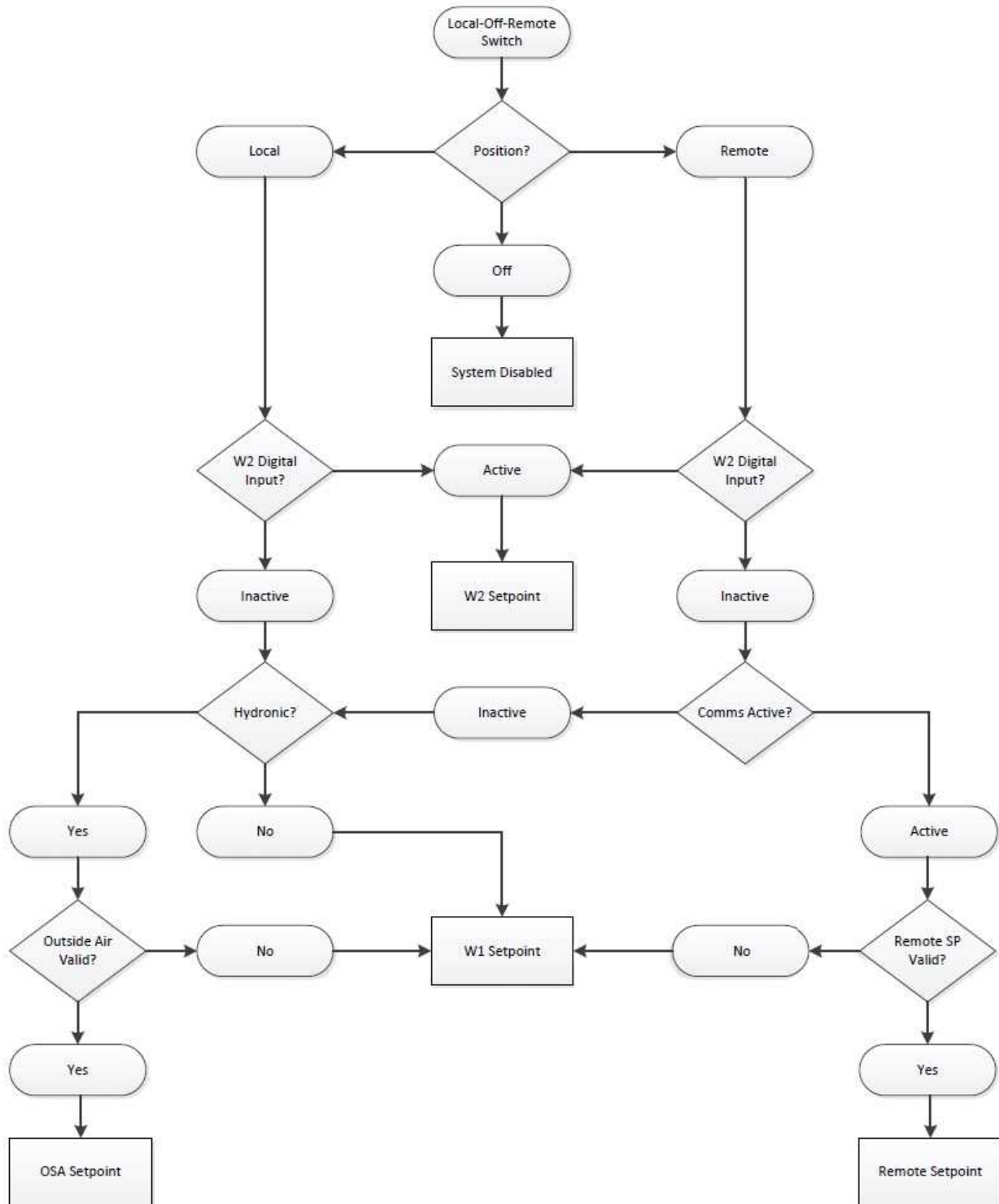

System Overview (continued)

Navigation Shortcuts from Overview

Touching the boiler image will navigate to the **BOILER OVERVIEW** screen (see *Boiler Overview* section for additional detail).

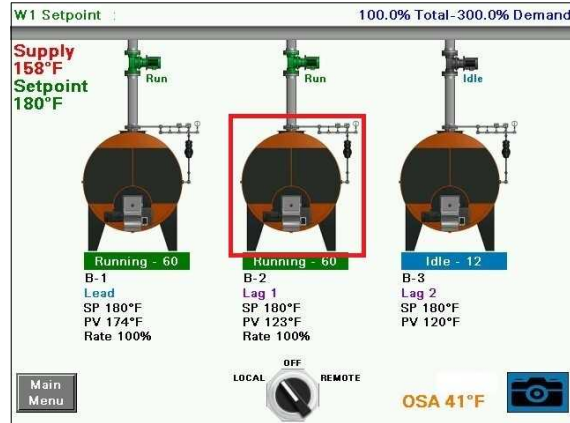

Touching the boiler information will display the boiler **HAND-OFF-AUTO** switch (see *Boiler Overview* → *Hand-Off-Auto* section for additional detail).

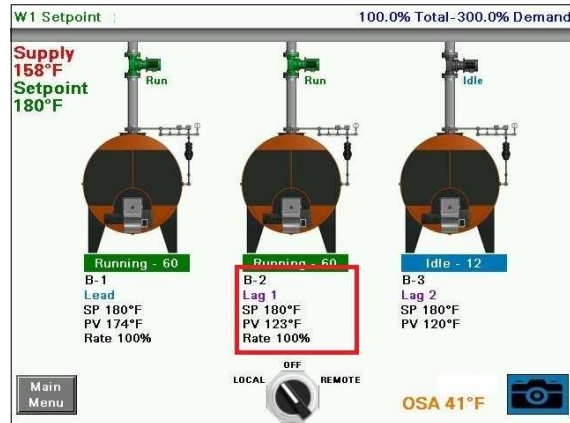

System Overview (continued)

Boilers 5-8

Systems with greater than four boilers connected will have a split overview screen. To see boilers 5-8, press **CONTINUE >>**. To return to boilers 1-4, press **<< BACK**.

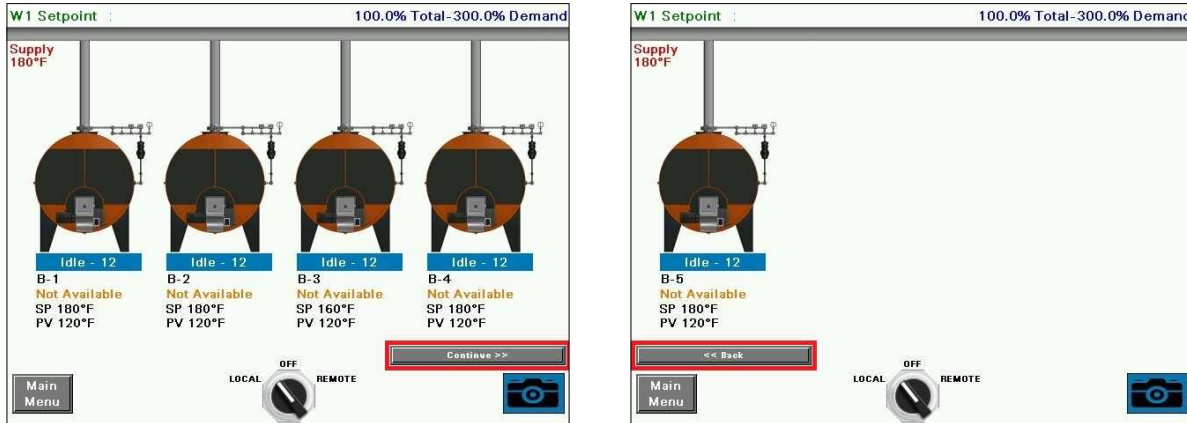

Forcing Screen Saver

To force the display of the screen saver, press one of the top corners from the SYSTEM OVERVIEW screen.

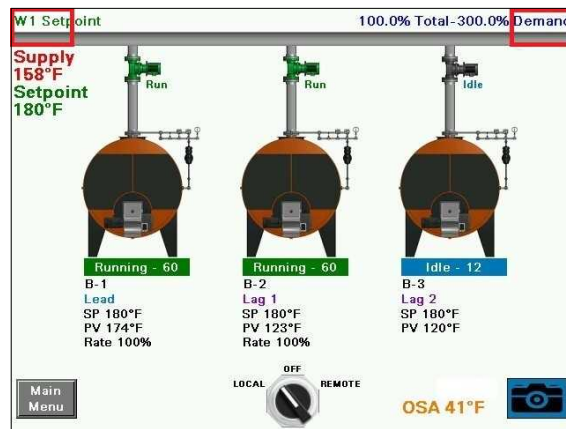

Loop Control Overview

Access level: **USER**

Touching the button on the overview screen that displays the tag name of the enabled loop control will display the loop control operating overview.

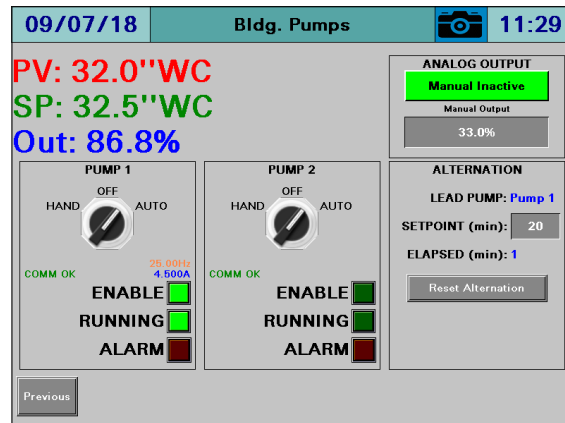

PV: Displays the loop process variable.

SP: Displays the loop setpoint. Touching the setpoint will allow it to be changed (TECH required).

Out: Displays the output in percent.

Manual Active/Inactive: Toggles between the output being automatic or manual.

Manual Output: Displays the commanded manual output in percent.

Hysteresis Option

Digital Output HAND-OFF-AUTO – Controls the digital output.

- **HAND:** The output is always enabled.
- **OFF:** The output is always disabled.
- **AUTO:** The output is automatically controlled using the hysteresis values.

Loop Control Overview (continued)

Two Pumps Option

PUMP 1/PUMP 2 HAND-OFF-AUTO – Controls the digital output to each pump.

- **HAND:** The output is always enabled.
- **OFF:** The output is always disabled.
- **AUTO:** The output is automatically controlled using the alternation.

COMM: Displays the communication status (Modbus only).

AMPS: Displays the operating current in amps (Modbus only).

HERTZ: Displays the operating frequency in hertz (Modbus only).

ENABLE: Displays the enable status of the output.

RUNNING: Displays the run status of the pump. This is connected to digital input 1 for pump 1 and digital input 2 for pump 2.

ALARM: Displays the alarm status of the pump. This may be connected to digital input 3 for pump 1 and digital input 4 for pump 2 if the pumps can generate their own alarms.

Alternatively, the timed alarms can be used. If the alarm is a timed alarm, a **Reset** push button will display when the alarm is present.

LEAD PUMP: Displays which pump is the lead pump.

SETPOINT (min): Displays pump alternation setpoint in minutes. This can be changed (TECH required).

ELAPSED (min): Displays pump alternation time elapsed in minutes.

Reset Alternation: Resets the alternation elapsed to zero and resets the lead pump to pump 1.

SYSTEM PERMISSIVE: Displays the enable status of the system permissive for steam applications (normally used for a low water cut-off).

Boiler Overview

Access level: **USER**

The boiler overview screen displays the real-time data for the specific boiler. From the MAIN MENU screen, press **B-x DETAIL**. The BOILER OVERVIEW screen will appear for the selected boiler.

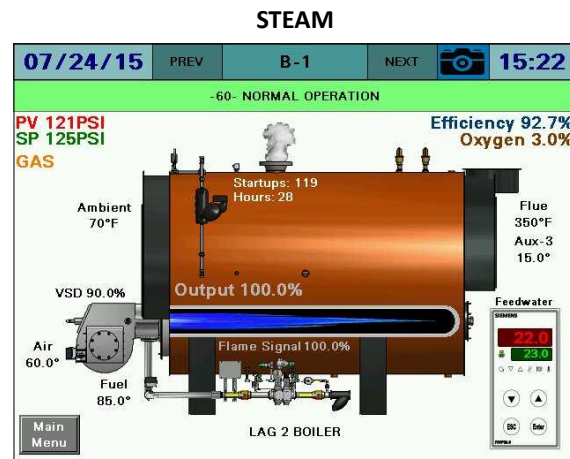
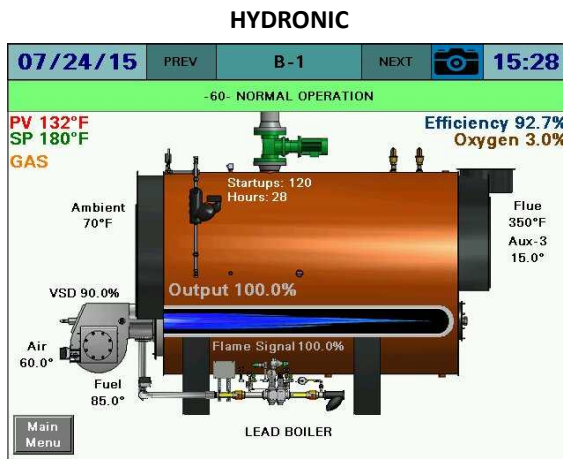

Use the **PREV** and **NEXT** buttons to navigate between boilers.

Boiler Overview (continued)

Phase: The phase of the boiler is always displayed in a horizontal bar at the top of the screen.

PV: Displays the actual value of the boiler.

SP: Displays the current setpoint of the boiler.

Fuel In Use: Displays the current fuel being used (uses fuel tags).

Firing Rate: Displays the firing rate of the boiler from 0-100%.

Manual Active: Displayed in red text if the boiler is in manual mode.

Air Actuator: Displays the position of the air actuator.

Fuel Actuator: Displays the position of the current fuel actuator.

Aux Actuators: Displays the position of the auxiliary actuators if equipped (LMV5... only).

VSD Output: Displays the speed of the VSD from 0-100%.

Shell Temp: Displays the current boiler shell temperature (steam systems only).

Inlet Temp: Displays the current boiler inlet temperature (hydronic systems only).

Startups: Displays the number of boiler startups on the selected fuel.

Hours: Displays the number of hours run on the selected fuel.

O₂: Displays the current O₂ percentage in the stack (LMV5... only).

Flue Temp: Displays the current flue gas temperature (LMV5... only).

Ambient: Displays the current ambient temperature (LMV5... only).

Efficiency: Displays the current combustion efficiency (LMV5... only).

Feedwater: Displays the current RWF data. The red display is the actual level and the green display is the setpoint (steam systems only).

Pump/Valve Status: Displays the current boiler pump or valve status. A green pump indicates running, a red pump indicates pump alarm, and a gray pump indicates idle, while valve positions are indicated by text with no graphic (hydronic systems only).

Lead/Lag Status: Displays the current lead/lag status. See **Table 3** for a full list of messages.

Table 3: Lead/Lag Status Messages

Message	Definition
LEAD/LAGx BOILER	The current boiler designation.
LEAD/LAGx BOILER – WSB ACTIVE ON TEMP	The current boiler designation, also indicates that warm standby is active due to temperature.
LEAD/LAGx BOILER – WSB MIN RUN	The current boiler designation, also indicates that warm standby is active due to unsatisfied minimum run timer after temperature satisfied.
FORMER LEAD – CHANGEOVER IN PROGRESS	The boiler is transitioning from a lead boiler to a lag boiler.
BOILER NOT AVAILABLE	The boiler is not available due to one of the following reasons (boiler control switch is off, boiler is not in automatic mode, boiler is in lockout, or boiler with LMV5... controller is not set for "IntLC Bus").
OVERRIDE MODE	The override input on the lead/lag master is activated and is the source of control.

Boiler Overview (continued)

Hand-Off-Auto

Touching the area below the boiler image on the **SYSTEM OVERVIEW** screen or touching the boiler image on the **B-x DETAIL** screen will display the HAND-OFF-AUTO switch.

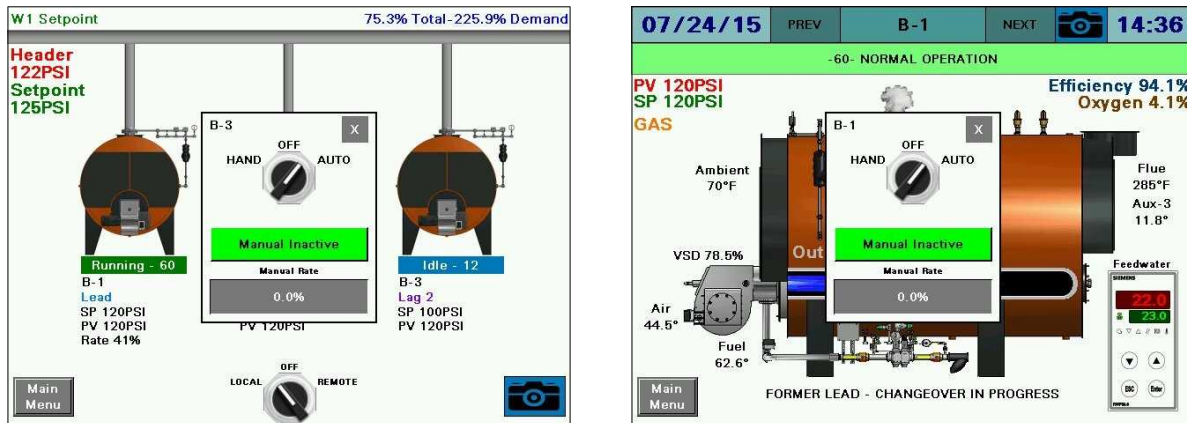

HAND-OFF-AUTO – Sets the mode of the boiler to manually on, manually off, or automatic. See **Table 4** for additional detail. The position will synchronize with the HAND-OFF-AUTO switch located on the touchscreen kit, if applicable.

- **HAND:** The boiler is commanded to run.
- **OFF:** The boiler is commanded to remain off.
- **AUTO:** The boiler is commanded to operate via the Lead/Lag Master commands.



Warning: If the LMV5 is in firing rate control mode, an external automatic reset temperature control must be present on the boiler since the internal load control thermostat function is not active in this mode.

MANUAL ACTIVE/INACTIVE – Select manual forced operation when in **HAND**.

- **INACTIVE**
- **ACTIVE**

MANUAL RATE – Sets the firing rate when manual operation is enabled.

Table 4: LMV Actions in HAND/OFF/AUTO

Position	Local/Remote	Remote Mode	Setpoint Used	Firing Rate Used
HAND (Manual Inactive)	Local	n/a	W1/W2	Internal LC
HAND (Manual Active)	Remote	Burner On	W3	Remote
OFF	Remote	Burner Off	W3	n/a
AUTO (Commanded On)	Remote	Burner On	W3	Remote
AUTO (Commanded Off)	Remote	Burner Off	W3	n/a

Boiler Overview (continued)

Hand-Off-Auto Flowchart (Serial Connection)

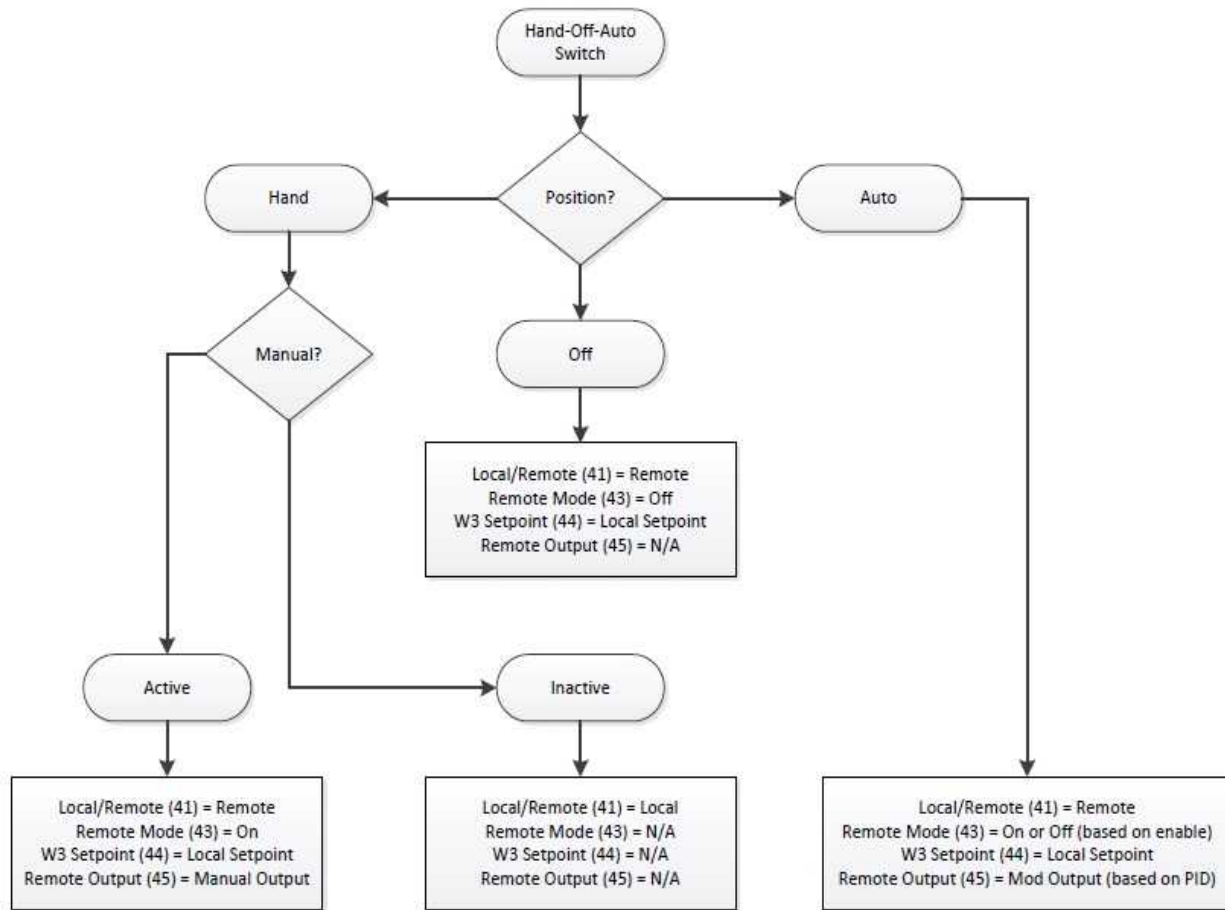

Boiler Overview (continued)

Hand-Off-Auto Flowchart (Touchscreen Kit)

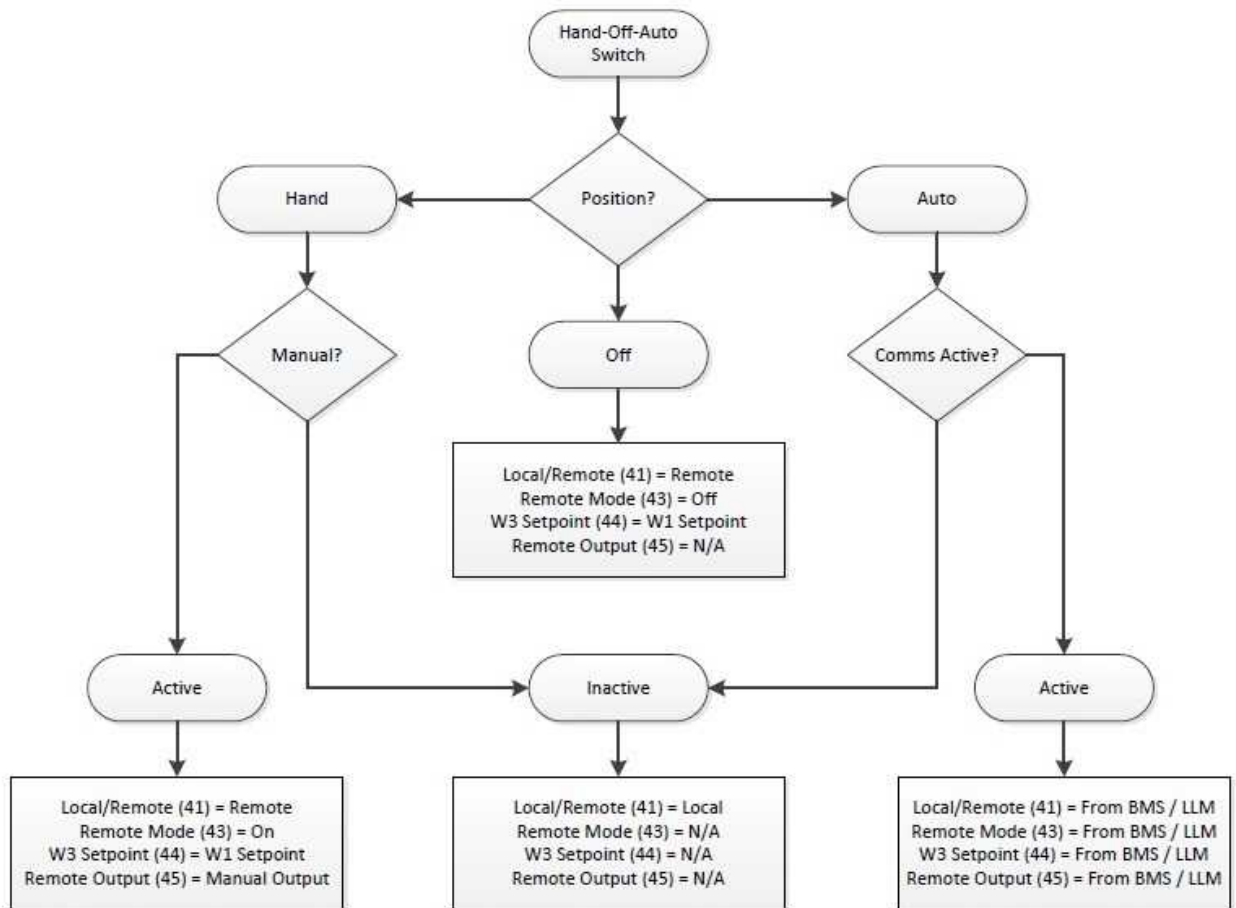

Boiler Overview (continued)

Boiler Available Status

Touching the lead/lag status message from the **B-x DETAIL** screen will display the BOILER AVAILABLE detail screen.

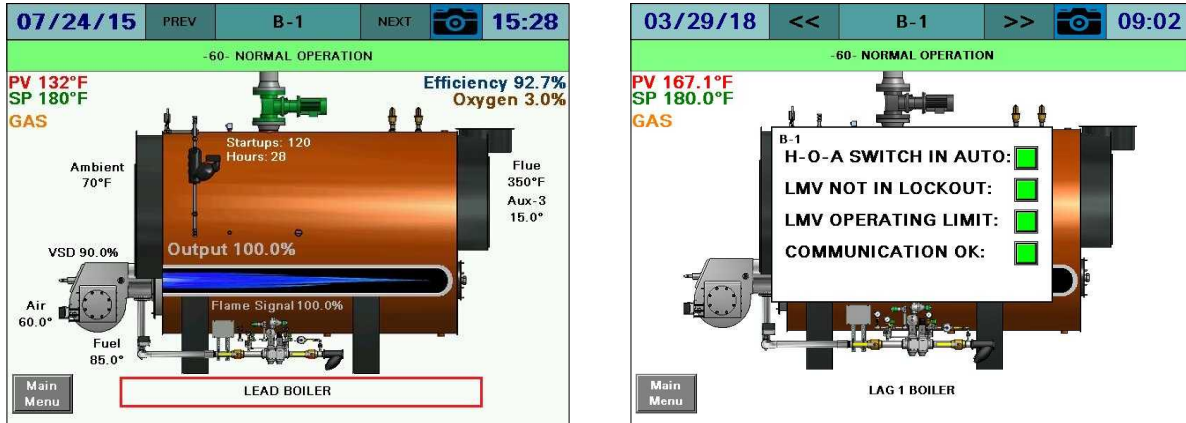

LMV3x/RWF55 Open Limits Option

When using the LMV3x/RWF55 load controller option, an option exists to open the 1N/1P limits of the RWF55 when the boiler is disabled. Normally this is not done so that the boiler available status can continue to be used. If this option is activated, the boiler will always be available regardless of the status of the control switch or operating limits. Other availability factors such as H-O-A in auto and not in lockout will still apply.

This option may be used if it is important to open the limit string for external devices such as a draft control or a combustion air damper.

To activate, set the RWF55 parameter **dt** for the particular boiler to any value ending in 7 (such as 27).

LMV5x/RWF55 Load Controller Option



When using the LMV5x/RWF55 load controller option, the available status is handled in a different way. If the RWF enable is present but the LMV5... control switch input is not made for the duration of the RWF AVAILABLE DELAY parameter (see *Modbus Stats RWF* section for additional detail), the boiler will be marked as unavailable. When it is unavailable, it will be enabled periodically to test if it is available. This can not be automatic since the boiler normally will not be enabled if it is not available. To force the available test, press the **Test Limits** button as shown on the BOILER AVAILABLE detail screen. This button will only display when the boiler is unavailable due to LMV5... control switch input as described above.

Setpoints

Access level: **USER/TECH/SETUP**

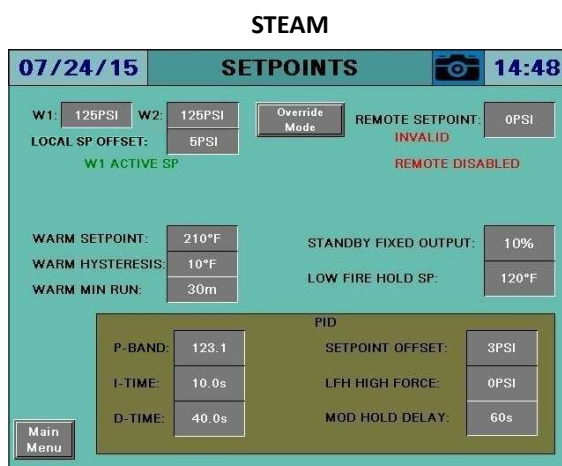
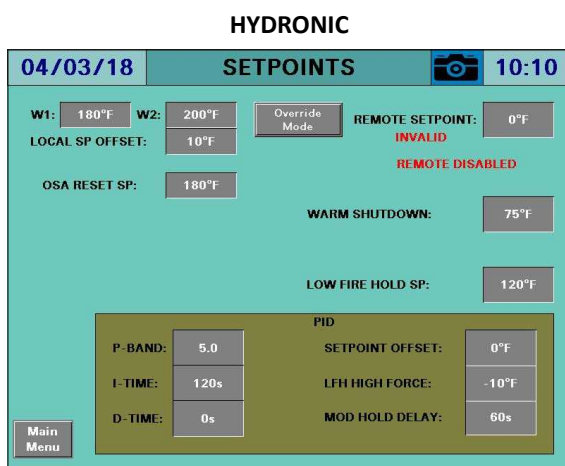
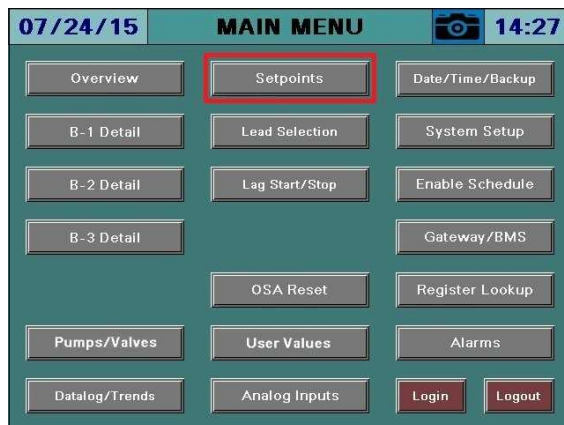
The setpoint setup screen displays system setpoint configuration. From the MAIN MENU screen, press **SETPOINTS**. The SETPOINTS screen will appear.



-  **Warning:** The connected LMV must be commissioned using accurate fuel flow metering. Failure to do so may result in poor performance since the required firing rate will not correspond to a linear burner output. It may not be possible to find suitable PID settings to control under this scenario since the feedback will not be representative.
-  **Warning:** If the LMV5 is in firing rate control mode, an external automatic reset temperature control must be present on the boiler since the internal load control thermostat function is not active in this mode.

Setpoints (continued)

Dual-fuel With Staged Oil

If the burner is dual-fuel with modulating gas and staged oil, the burner must be manually operated to the maximum number of stages while connected. Doing so sets staged mode for oil as well as the number of stages. This allows for the number of stages enabled to be proportional to the firing rate command as well as the manual fire output to display as stages.

System Setpoints

W1, W2 SETPOINT – Sets the W1 or W2 setpoint. In hydronic systems, W1 is used in the absence of a valid outside air setpoint. In steam systems W1 is the header setpoint. On all systems, W2 is the overriding setpoint when the 'W2' digital input is activated.

LOCAL SP OFFSET – Sets the desired local boiler setpoint offset (TECH required). The local boiler setpoint is determined by adding this offset to the current system setpoint. Note that when a LMV5... load controller is used, the AZL will display the current system setpoint but the local boiler setpoint will still be used to calculate firing rate restrictions. *For systems with an RWF load controller, this setpoint must be greater than zero to prevent local boiler cycling on limits and to ensure proper system operation.*

REMOTE SETPOINT – Displays the remote setpoint. Also displays the status of the remote setpoint. 'INVALID' indicates inactive communication, 'REM OK' indicates active communication, and 'DIGITAL' indicates a hardwired remote setpoint.

REMOTE STATUS – Displays the remote enable status. If the remote setpoint is 'REM OK' or 'DIGITAL', the remote status of 'REMOTE DISABLED' or 'REMOTE ENABLED' will be followed when the system is in remote control mode.

OSA RESET SP – Displays the calculated outside air reset setpoint when an outside air sensor is connected and outside air reset is enabled. Also indicates when the outside air reset setpoint is active.

W2 CHANGEOVER – Displays the W2 setpoint changeover temperature when an outside air sensor is connected (TECH required). This changeover applies whether the system is in local or remote. The changeover occurs if the system is at or above the setpoint for a period of one minute. This can be used for a summer/winter setpoint changeover. This is a parallel option to using contacts for switching to W2. If this function is not desired, set the value to a high temperature that will not be reached.

WARM SHUTDOWN – Displays the system shutdown temperature when an outside air sensor is connected (TECH required). This shutdown applies whether the system is in local or remote. The shutdown occurs if the system is at or above the setpoint for a period of five minutes. The system will enable immediately when the temperature drops below the shutdown setpoint. If this function is not desired, set the value to a high temperature that will not be reached.

Setpoints (continued)

Boiler Protection

WARM SETPOINT – Sets the warm standby setpoint (TECH required). This is the nominal temperature that the configured standby boilers will maintain while idle.

WARM HYSTERESIS – Sets the hysteresis band for the warm standby setpoint (TECH required). The off point will be (setpoint plus hysteresis) and the on point will be (setpoint less hysteresis).

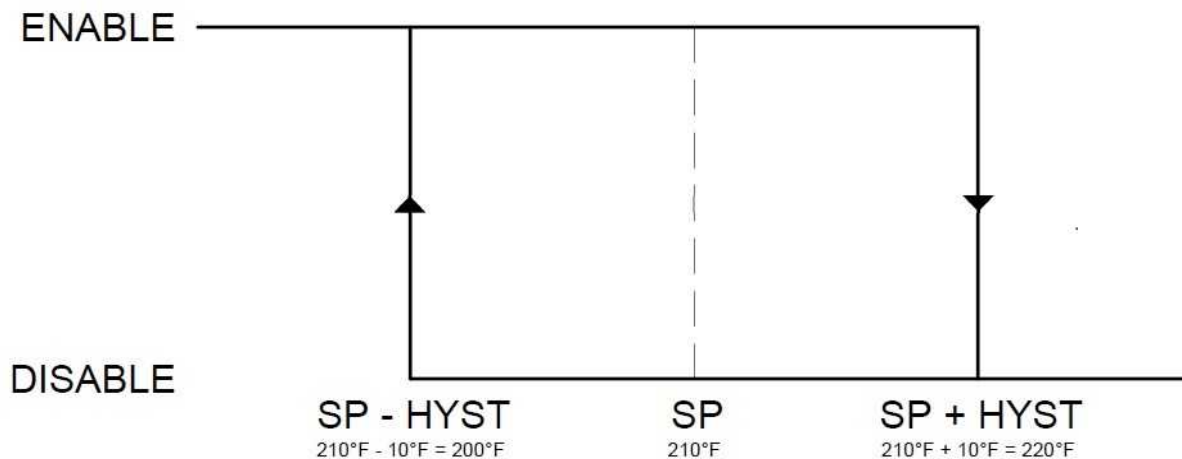

WARM MIN RUN – Sets the minimum run time for the warm standby enable (TECH required). Prevents short-cycling during warm standby operation.

STANDBY FIXED OUTPUT – Sets the firing rate used when warm standby is active (TECH required).

LOW FIRE HOLD SP – Sets the low fire hold setpoint (TECH required). Whenever the boiler shell (steam) or actual (hydronic) temperature is below this setpoint only low fire operation will be allowed.

Setpoints (continued)

Demand (PID)

PROPORTIONAL – Sets the proportional band for PID control (TECH required). The proportional portion of the control output is generated by the actual value relative to the setpoint less the proportional band. A smaller proportional band has a larger impact upon the process. For example, if the actual value is 95, the setpoint is 100 and the proportional band is 20, the control output will be 25% of the PID scale (setpoint minus actual, divided by the proportional band). The control output will modulate whenever the actual value is within the proportional band (80 to 100 in example). If the actual value is above or below the proportional band limits the control output will be the PID maximum or PID minimum. Setting the proportional band to 0 disables the PID control.

INTEGRAL – Sets the integral time for PID control (TECH required). The integral portion of the control output makes continuous adjustments based upon the error between the setpoint and the actual value. A shorter integral time has a larger impact upon the process. For example, if the output using the proportional band alone is 25% and the integral time is set to 15s, the control output will double to 50% in 15s if the control variables remain constant. This 'integral windup' will continue until the control output reaches the PID maximum or PID minimum. Setting the integral time to 0 disables the integral portion.

DERIVATIVE – Sets the derivative time for PID control (TECH required). The derivative portion of the control output makes periodic adjustments based upon the rate of change in the actual value. A larger derivative time has a larger impact upon the process. For example, if the output using the proportional band alone is 25%, the derivative time is set to 10s and the actual value decreases by 2, the control output will increase by 20% (10×2) in anticipation of how much the current rate of change would affect the process 10s into the future. Setting the derivative time to 0 disables the derivative portion. Derivative should be used with caution as it can create an unstable control loop. When used, it is recommended that derivative time not exceed 25% of the integral time.

SETPOINT OFFSET – Sets the setpoint offset for the PID control (TECH required). The setpoint offset is added to the desired setpoint to create the effective setpoint used by the PID control. For example, if the setpoint is 100 and the setpoint offset is 3, the setpoint used by the PID control would be 103.

LFH HIGH FORCE – Sets the setpoint for forcing modulation toward low fire at the individual boilers (TECH required). LFH high force is added to the local setpoint to create the effective high force setpoint. For example, if LFH high force is 3 and the local setpoint is 180, modulation toward low fire will be forced when the individual boiler pressure (steam) or temperature (hydronic) equals 180 and low fire will be achieved after 183. If LFH high force is -3 and the local setpoint is 180, modulation toward low fire will be forced when the individual boiler pressure (steam) or temperature (hydronic) equals 177 and low fire will be achieved after 180.

Setpoints (continued)

MOD HOLD DELAY – Sets the time that low fire operation will continue after being released to modulation (TECH required). This delay applies after any condition that calls for low fire (initial run, low fire hold on temperature, or LFH high force).

Firing Rate Restrictions

The chart below shows an example of how the firing rate is restricted using the different available settings. The bar graph represents the boiler temperature or pressure. The color of the bars indicates how the firing rate will be restricted. Normal firing rate refers to the firing rate that the system determines based upon the PID. Note that both LOCAL SP OFFSET and LFH HIGH FORCE may be either positive or negative values. Negative values will reverse the direction of the action.

Positive Low-Fire Forcing



* - Local SP is displayed on RWF load controllers, Current SP is displayed on LMV5x load controllers.

Setpoints (continued)

Negative Low-Fire Forcing

Local SP Offset = 5	Local SP = 185 (Current SP + 5)*
Current SP = 180	Current SP can be W1, W2, OSA or Remote
LFH High Force = -5	Scales From 180 (Local SP - 5) to 185 (Local SP)

Low Fire Hold SP = 120	Low fire hold is always temperature-based
------------------------	---



* - Local SP is displayed on RWF load controllers, Current SP is displayed on LMV5x load controllers.

Setpoints (continued)

PID Tuning Notes

Begin tuning by setting the **P-BAND** variable to something between 5%-10% of the desired setpoint. Set the **I-TIME** and **D-TIME** to 0s each. Normally using P only in a PID loop means that you will not be able to reach the setpoint. With a boiler, however, the output at low fire may be greater than the lowest load setting. This will allow the system to work without using I or D. In this case, also choosing settings that allow the process variable to exceed the setpoint by as much as can be tolerated will reduce the cycling of the boiler. If the low fire is not too large, introduce I by setting **I-TIME** to a large number such as 600s. If this is too slow gradually reduce this number until the results are as desired. Setting only P and I should be all that is needed for most applications since the process does not have a fast response. If D is still desired by an experienced user, it is not advised to have the D exceed 25% of the I setting.

Override Mode

An override mode is available that will force specific commands to each boiler when the 'Override' digital input is activated. This can be used for a manual warm-up or for a forced production output. In this mode, the PID will operate from 0% to 100% based on demand. From the SETPOINTS screen press **OVERRIDE MODE** to display the OVERRIDE MODE window (TECH required).

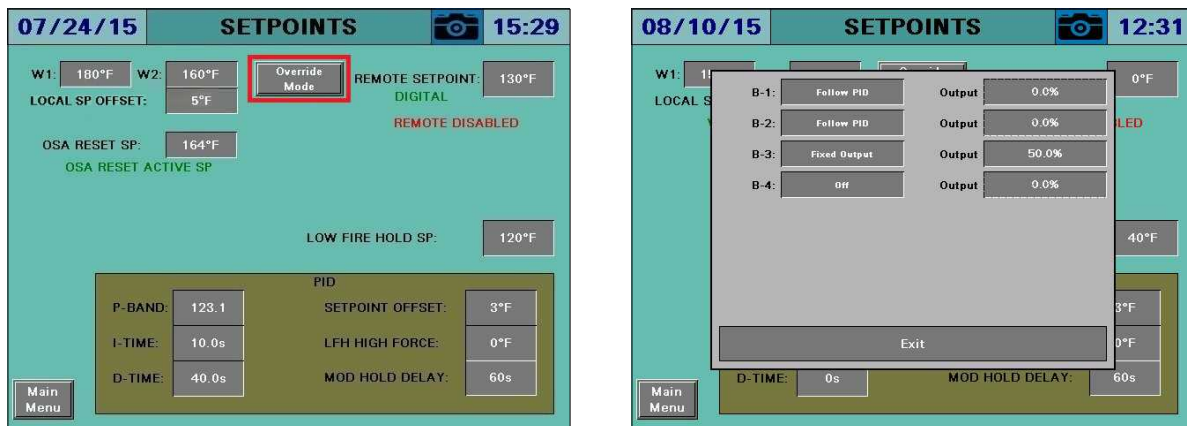

BOILER COMMAND – Selects the desired override action.

- **Local Operation:** The boiler will be commanded to run in local mode.
- **Fixed Output:** The boiler will be commanded to run using a fixed output. This is similar to manual operation (see *Boiler Overview* → *Hand-Off-Auto* section for additional detail).
- **Off:** The boiler will be commanded off.
- **Follow PID:** The boiler will be commanded to follow the PID output. There are no start/stop points in this mode, the boiler will always be commanded to run.

Lead Selection

Access level: **USER/TECH/SETUP**

The lead selection setup screen displays lead boiler configuration. From the MAIN MENU screen, press **LEAD SELECTION**. The LEAD SELECTION screen will appear.



LEAD BY ALTERNATION



LEAD BY LMV STARTUPS OR LMV HOURS



Lead Selection (continued)

Two methods of lead alternation are provided as well as an option to force a lead boiler without alternation. See *System Setup* for further information about selecting and configuring the lead mode. In any lead mode, the system will try to keep the assigned lead as lead whenever possible but will temporarily change lead as needed due to a boiler becoming unavailable.

Lead By Alternation

BOILERS AVAILABLE – Displays the number of boilers that are available to the system.

ALTERNATION SETPOINT (ALTERNATION) – Sets the desired alternation setpoint (TECH required).

HOURS, MINUTES REMAINING – Displays how many hours and minutes remain until automatic alternation occurs. Note that this time will elapse whether it is the assigned lead running or a temporary lead running.

LEAD CHANGE OVERLAP – Sets the desired lead change overlap time (TECH required). This determines how long that the former lead boiler will continue to follow the lead boiler commands following a change in the lead boiler, ensuring no interruption in the system.

MANUAL ALTERNATION TO NEXT LEAD (ALTERNATION) – Press to manually change to the next available lead boiler (TECH required).

RESET ALTERNATION COUNTER (ALTERNATION) – Press to reset the alternation counter (TECH required).

LEAD, LAG BOILERS – Displays the current assignments of the lead and lag boilers.

ASSIGNED LEAD – Displays the boiler that is assigned to be the lead boiler when it is available. The system will always return to the assigned lead whenever possible.

Lead Selection (continued)

Lead By LMV Startups or LMV Hours

BOILERS AVAILABLE – Displays the number of boilers that are available to the system.

STARTUPS, HOURS HYSTERESIS (STARTUPS, HOURS) – Sets the desired hysteresis setpoint (TECH required). Whenever a lag boiler counter (startups or hours as selected) trails the lead counter by more than the hysteresis setpoint, that lag boiler will become the new lead.

Example: B-1 has 100 hours, B-2 has 120 hours and B-3 has 130 hours. B-3 is lead and the hysteresis setpoint is 60 hours. B-3 will be lead until it has 160 hours, which is 60 more hours than B-1 has. B-1 will then be lead until it has 180 hours, which is 60 more hours than B-2 has. B-2 will then be lead until it has 220 hours, which is 60 more hours than B-3 has. This method of rotation will keep the startups or hours close over a long period of time.

LEAD CHANGE OVERLAP – Sets the desired lead change overlap time (TECH required). This determines how long that the former lead boiler will continue to follow the lead boiler commands following a change in the lead boiler, ensuring no interruption in the system.

LEAD, LAG BOILERS – Displays the current assignments of the lead and lag boilers.

ASSIGNED LEAD – Displays the boiler that is assigned to be the lead boiler when it is available. The system will always return to the assigned lead whenever possible.

BOILER STARTUPS, HOURS (STARTUPS, HOURS) – Displays the startups or hours of the boilers.

Resetting RWF55 Startups/Hours

When using the load controller "RWF55 Only", the internally counted startups and hours can be reset by setting the local RWF55 parameter **dt** to 1 temporarily until the startup and hours display zero. Restore **dt** to the original setting following this operation.

Count Offset

Positive or negative offsets can be added to the startups or hours for each boiler. This may be necessary when a device is replaced to keep the functional startups and hours relative to the other devices in the system.

B-1	10000
B-2	0
B-3	0
B-4	0
B-5	0
Exit	

Lead Selection (continued)

Forced Lead

BOILERS AVAILABLE – Displays the number of boilers that are available to the system.

FORCE LEAD – Choose the lead boiler desired (TECH required). This will always be the lead boiler when it is available.

LEAD CHANGE OVERLAP – Sets the desired lead change overlap time (TECH required). This determines how long that the former lead boiler will continue to follow the lead boiler commands following a change in the lead boiler, ensuring no interruption in the system.

MANUAL ALTERNATION TO NEXT LEAD (ALTERNATION) – Press to manually change to the next available lead boiler (TECH required).

RESET ALTERNATION COUNTER (ALTERNATION) – Press to reset the alternation counter (TECH required).

LEAD, LAG BOILERS – Displays the current assignments of the lead and lag boilers.

Lead Skip (W1, W2)

Boilers can be left out of the lead rotation if desired. A separate sequence is programmed for all setpoints other than W2 (**LEAD SKIP W1**) and for W2 (**LEAD SKIP W2**). Pressing either button will display the window allowing the rotation option to be selected.

- **In Rotation:** The boiler will rotate in as lead using the chosen method in a normal manner.
- **Skip:** When the chosen boiler is designated to be lead, the system will automatically advance to the next boiler.

Lead Rotation (W1, W2)

The initial rotation order can be set to allow for a custom sequence. A separate sequence is programmed for all setpoints other than W2 (**LEAD ROTATION W1**) and for W2 (**LEAD ROTATION W2**). Pressing either button will display the window allowing the rotation sequence to be set. For the system to operate correctly, each boiler must be accounted for (chosen only once) with no duplication or boilers left out.

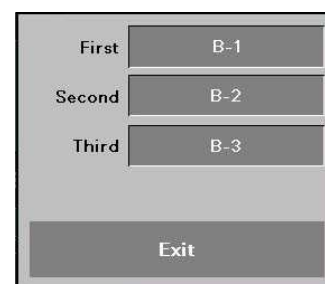
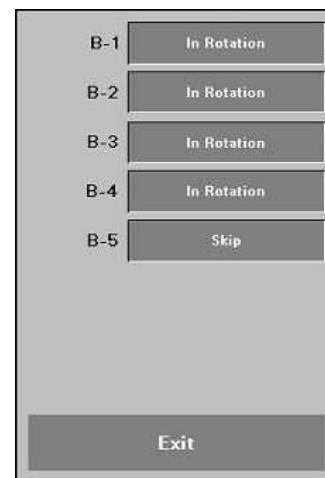

Lag Start/Stop

Access level: **USER/TECH/SETUP**

The lag start/stop setup screen displays lag boiler sequencing configuration. From the MAIN MENU screen, press **LAG START/STOP**. The LAG START/STOP screen will appear.

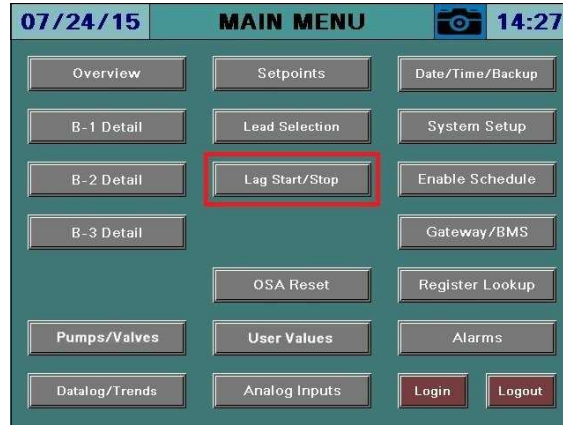

PARALLEL OR PARALLEL PV MODULATION

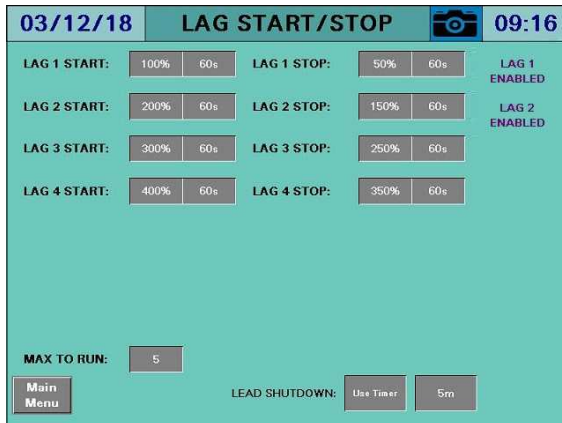

SEQUENTIAL MODULATION



Lag Start/Stop (continued)

Three methods of modulation are provided. See *System Setup* for further information about configuring the modulation mode.

Parallel Modulation

LAG STARTS (PERCENT AND TIME) – Sets the start point and delay time for each lag boiler (TECH required). When the load demand exceeds the start point for the time duration specified it will become enabled.

LAG STOPS (PERCENT AND TIME) – Sets the stop point and delay time for each lag boiler (TECH required). When the load demand falls below the stop point for the time duration specified it will become disabled.

LAG ENABLE STATUS – Displays 'LAG x ENABLED' whenever a lag boiler is enabled.

MAX TO RUN – This is the maximum number of boilers that can be enabled, including the lead (TECH required). A separate sequence is programmed for all setpoints other than W2 (**MAX TO RUN W1**) and for W2 (**MAX TO RUN W2**).

LEAD SHUTDOWN DELAY – Sets the required parameter for the lead boiler to become disabled.

- **Use Timer:** Sets the duration that the lead boiler must run at low fire (no demand) before being disabled.
- **Use PV:** Creates an off setpoint by adding the value of this parameter to the system setpoint. If the lead off setpoint is 2PSI and the system setpoint is 10PSI, the lead will become disabled when the header pressure is equal to or greater than 12PSI.
- **Disabled:** The lead boiler will never be disabled.

Output

PID output ranges from 0% to (100% x number of boilers available). An available boiler is one that can be operated by the Lead/Lag Master. For example, if there are 5 boilers in a system but only 3 are available, the max PID output will be 300%. If none are available, PID will be disabled to avoid wind-up and the screen will display 'NO BOILERS AVAILABLE' instead of a PID output percent.

Enables

The start and stop percentages will be based upon the total output percentage. If lag 1 has a start percentage of 100%, the start timer will begin when the PID output exceeds 100% and the lead boiler is running. The effect of this would be to start lag 1 when the lead boiler is at 100% firing rate. The stop percentage must be lower than the start percentage, so that it will take effect when the demand begins to drop. Each subsequent lag boiler should have a higher start and stop percentage than the previous lag boiler. It is advised to have a significant start delay to ensure that the demand is steady. The stop delay can be shorter. If parallel operation at lower firing rates is desired, use lower start percentages.

Lag Start/Stop (continued)

Firing Rates

The firing rates sent to the boilers will be the PID output divided by the number of boilers running, clipped at 100%. Each boiler is subject to a modulation delay once the fuel valve opens, and will hold at low fire until this is complete. Other situations that force low fire operation are when a boiler local actual value is greater than the local boiler setpoint plus the "low-fire hold force above setpoint" parameter ("software relief valve") or when the boiler actual (hydronic) or shell (steam) temperature is below the "low fire hold setpoint".

Example

A system is set up for 3 boilers and all 3 are available.

- Lag 1 is set to start at 80%, stop at 40%
- Lag 2 is set to start at 200%, stop at 150%

The lead starts when the load demand (output) exceeds 2% (a fixed value) and modulates directly to the output value. Once the output exceeds 80%, the lag 1 timer starts. By the time lag 1 begins running the output is 90%, so the lead and lag boiler each are sent a firing rate of 45%. This causes the lead boiler to modulate down from 90% to 45%. The output continues to increase due to demand, and once it exceeds 200% the process repeats for lag 2. The lead and lag 1 boilers modulate down from 100% each to 67% each, and lag 2 joins with a firing rate of 67% as well. If demand increases to the max of 300%, all three will be at 100% firing rate. If the output drops below 150% (each boiler firing rate at 50%), the lag 2 boiler turns off and the lead and lag 1 boilers will modulate at 75% each. Once the output drops below 40%, lag 1 is also shed and the lead boiler goes up to 40% from 20%. The lead boiler will then shut off if the parameters for lead shutdown are satisfied.

Lag Start/Stop (continued)

Parallel PV Modulation

LAG STARTS (PERCENT AND TIME) – Sets the start point and delay time for each lag boiler (TECH required). When the process variable falls below the start point for the time duration specified it will become enabled. The start percent is converted to a temperature or pressure for display to help with selecting a setpoint.

LAG STOPS (PERCENT AND TIME) – Sets the stop point and delay time for each lag boiler (TECH required). When the process variable exceeds the stop point for the time duration specified it will become disabled. The stop percent is converted to a temperature or pressure for display to help with selecting a setpoint.

LAG ENABLE STATUS – Displays 'LAG x ENABLED' whenever a lag boiler is enabled.

MAX TO RUN – This is the maximum number of boilers that can be enabled, including the lead (TECH required).

LEAD SHUTDOWN DELAY – Sets the required parameter for the lead boiler to become disabled.

- **Use Timer:** Sets the duration that the lead boiler must run at low fire (no demand) before being disabled.
- **Use PV:** Creates an off setpoint by adding the value of this parameter to the system setpoint. If the lead off setpoint is 2PSI and the system setpoint is 10PSI, the lead will become disabled when the header pressure is equal to or greater than 12PSI.
- **Disabled:** The lead boiler will never be disabled.

Output

PID output ranges from 0% to (100% x number of boilers available). An available boiler is one that can be operated by the Lead/Lag Master. For example, if there are 5 boilers in a system but only 3 are available, the max PID output will be 300%. If none are available, PID will be disabled to avoid wind-up and the screen will display 'NO BOILERS AVAILABLE' instead of a PID output percent.

Enables

The start and stop percentages will be based upon the process variable (PV). This can be either the loop supply, loop return or header pressure. The stop percentage must be higher than the start percentage, so that it will take effect when the PV begins to rise. Each lag boiler should have a lower start and stop percentage than the previous lag boiler so that they operate in a first on, last off sequence. For example, lag 1 may start at 98%, lag 2 at 96%, lag 3 at 94%, etc. and lag 1 may stop at 104%, lag 2 at 103%, lag 3 at 102%, etc.

Lag Start/Stop (continued)

Firing Rates

The firing rates sent to the boilers will be the PID output divided by the number of boilers running, clipped at 100%. Each boiler is subject to a modulation delay once the fuel valve opens, and will hold at low fire until this is complete. Other situations that force low fire operation are when a boiler local actual value is greater than the local boiler setpoint plus the "low-fire hold force above setpoint" parameter ("software relief valve") or when the boiler actual (hydronic) or shell (steam) temperature is below the "low fire hold setpoint".

Example

A system is set up for 3 boilers and all 3 are available, with a system setpoint of 100PSI.

- Lag 1 is set to start at 98% (98PSI), stop at 104% (104PSI)
- Lag 2 is set to start at 96% (96PSI), stop at 103% (103PSI)

The lead starts when the load demand (output) exceeds 2% (a fixed value) and modulates directly to the output value. Once the lead boiler is running, the lag 1 timer will start if the PV is below 98PSI. By the time lag 1 begins running the output is 90%, so the lead and lag boiler each are sent a firing rate of 45%. This causes the lead boiler to modulate down from 90% to 45%. Once lag 1 is running the lag 2 timer will start if the PV is below 96PSI. Once lag 2 is running, the lead and lag 1 boilers modulate down from 100% each to 67% each, and lag 2 joins with a firing rate of 67% as well. If demand increases to the max of 300%, all three will be at 100% firing rate. If the PV exceeds 103PSI, the lag 2 stop timer will be activated. If lag 2 has been disabled and the PV exceeds 104PSI, the lag 1 stop timer will be activated. As boilers turn off the firing rate will be redistributed among the remaining boilers equally. The lead boiler will then shut off if the parameters for lead shutdown are satisfied.

Lag Start/Stop (continued)

Sequential Modulation

LAG STARTS (PERCENT AND TIME) – Sets the start point and delay time for each lag boiler (TECH required). When the load demand exceeds the start point for the time duration specified it will become enabled.

LAG STOPS (PERCENT AND TIME) – Sets the stop point and delay time for each lag boiler (TECH required). When the load demand falls below the stop point for the time duration specified it will become disabled. The stop timer counts when the lag boiler is at low fire (stop percentage not used).

LAG ENABLE STATUS – Displays 'LAG x ENABLED' whenever a lag boiler is enabled.

MAX TO RUN – This is the maximum number of boilers that can be enabled, including the lead (TECH required).

LEAD SHUTDOWN DELAY – Sets the required parameter for the lead boiler to become disabled.

- **Use Timer:** Sets the duration that the lead boiler must run at low fire (no demand) before being disabled.
- **Use PV:** Creates an off setpoint by adding the value of this parameter to the system setpoint. If the lead off setpoint is 2PSI and the system setpoint is 10PSI, the lead will become disabled when the header pressure is equal to or greater than 12PSI.
- **Disabled:** The lead boiler will never be disabled.

Output

PID output ranges from 0% to (100% x number of boilers available). An available boiler is one that can be operated by the Lead/Lag Master. For example, if there are 5 boilers in a system but only 3 are available, the max PID output will be 300%. If none are available, PID will be disabled to avoid wind-up and the screen will display 'NO BOILERS AVAILABLE' instead of a PID output percent.

Enables

The start percentage for lag boilers is common to all and will be based upon a 100% individual firing rate. If the start percentage is 80%, the start timer will begin when the PID output of the previous boiler is at 80% and the previous boiler is running. The stop percentage in sequential mode is when the boiler is at low fire for the stop duration.

Lag Start/Stop (continued)

Firing Rates

The firing rates sent to the boilers will be an uneven distribution of the PID output. The lead and each subsequent lag boiler will modulate to a specified firing rate and hold there. The last lag boiler to start will modulate to trim the load.

Example

A system is set up for 3 boilers and all 3 are available.

- Start percentage of 80% (Lag 1 = 80%, Lag 2 = 160%)

The lead starts when the load demand (output) exceeds 2% (a fixed value) and modulates directly to the output value. Once the output exceeds 80%, the lag 1 timer starts. By the time lag 1 begins running the output is 90%, so the lead is sent a firing rate of 80% and lag 1 is sent a firing rate of 10%. The output continues to increase due to demand, and once it exceeds 160% the process repeats for lag 2. By the time lag 1 begins running the output is 190%. The lead and lag 1 boilers stay at 80% each, and lag 2 joins with a firing rate of 30%. If demand increases above 240% (80% times 3), all three will have an equal firing rate of 80% or greater. If the output drops below 160%, the lag 2 boiler turns off and the lead will remain at 80% and lag 1 will modulate down from 80%. Once the output drops below 80%, lag 1 is also shed and the lead boiler begins to modulate down from 80%. The lead boiler will then shut off if the parameters for lead shutdown are satisfied.

Force Setpoint Control LMV5...

An LMV5... can be forced to operate in setpoint mode by setting the following parameter:

- Params & Display > Access w-out PW > AZL > Modbus > Timeout = **99s**

In setpoint mode the LMV5... will control its own firing rate to maintain the system setpoint. Any firing rate sent to it will be ignored.

Deaerator

Access level: **USER/TECH/SETUP**

Up to two connected SCC Inc. Deaerator Control Panels may be connected. From the MAIN MENU screen, press the name of the connected deaerator (in this example **DA & SURGE TANK**). The associated deaerator overview screen will appear.

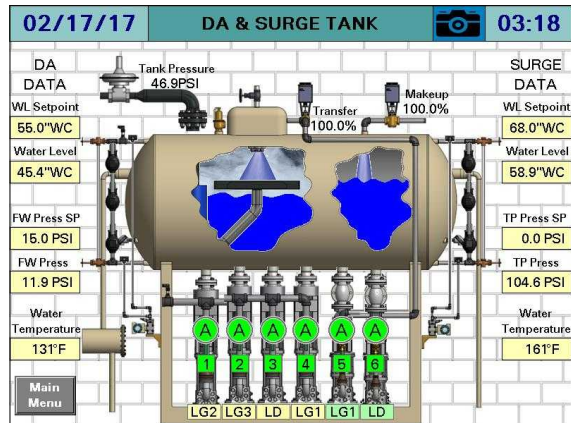
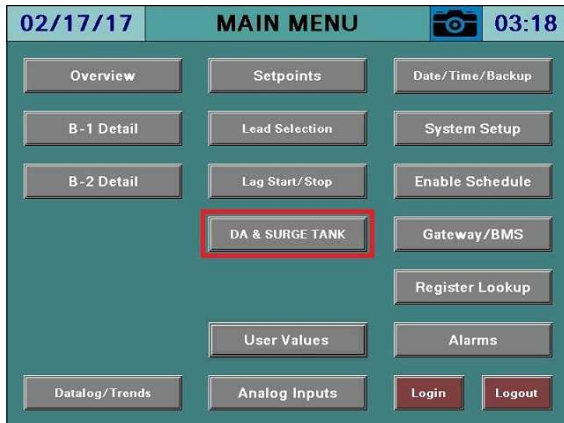

Pumps/Valves

Access level: **USER/TECH/SETUP**

The pumps/valves setup screen displays pumps/valves configuration. From the MAIN MENU screen, press **PUMPS/VALVES**. The PUMPS/VALVES screen will appear.

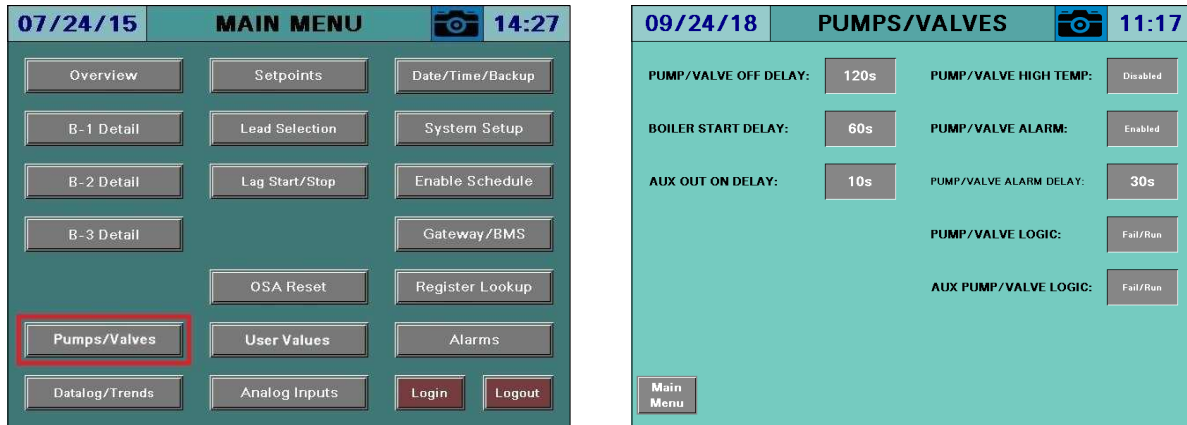

In a hydronic system, boiler circulating pumps or isolation valves can be cycled with the boiler. If there are four or fewer connected boilers, an auxiliary output with a separate on-delay timer is available.

PUMP/VALVE OFF DELAY – Sets the duration that the pump or valve will continue to be enabled after the boiler has been disabled (TECH required). This is used to remove latent heat from the vessel.

BOILER START DELAY – Sets the duration that the pump or valve will be enabled prior to the boiler being enabled (TECH required). This is used to promote flow in the boiler and equalize the internal temperatures.

AUX OUT ON DELAY – Sets the duration that the auxiliary pump or valve output will be enabled after the first pump output is enabled (TECH required). This can be used when a pump and isolation valve are used on the same boiler.

PUMP/VALVE HIGH TEMP – Select whether to run the boiler pump or open the valve when the boiler actual value is greater than the boiler local setpoint.

- Disabled
- Enabled

PUMP/VALVE ALARM – Select whether to generate an alarm if pump operation or valve open position is not proven.

- Disabled
- Enabled

PUMP/VALVE ALARM DELAY – Sets the duration that the pump operation or valve open position has to prove before an alarm is generated.

Pumps/Valves (continued)

PUMP/VALVE LOGIC – Select the logic used for the pump or valve outputs.

- **Fail/Run:** The output will be off when the pump or valve is enabled ("Fail to Heat" logic). This is intended to be used with an interposing relay connecting the normally closed contacts to a motor starter or valve. This results in all pumps operating or all valves opening upon a failure of the controller.
- **Fail/Off:** The output will be on when the pump or valve is enabled. This results in all pumps commanded off or all valves closing upon a failure of the controller.

AUX PUMP/VALVE LOGIC – Select the logic used for the auxiliary pump or valve outputs. The details of each mode are identical to the above parameter.

- **Fail/Run**
- **Fail/Off**

Outside Air Reset

Access level: **USER/TECH/SETUP**

The outside air temperature reset setup screen displays outside air temperature reset configuration. From the MAIN MENU screen, press **OSA RESET**. The OSA RESET screen will appear. If there are two Deaerator/Surge Tank Panels (DA/ST) connected (steam systems), the button to access the OSA RESET screen will be located on the SETPOINTS screen.

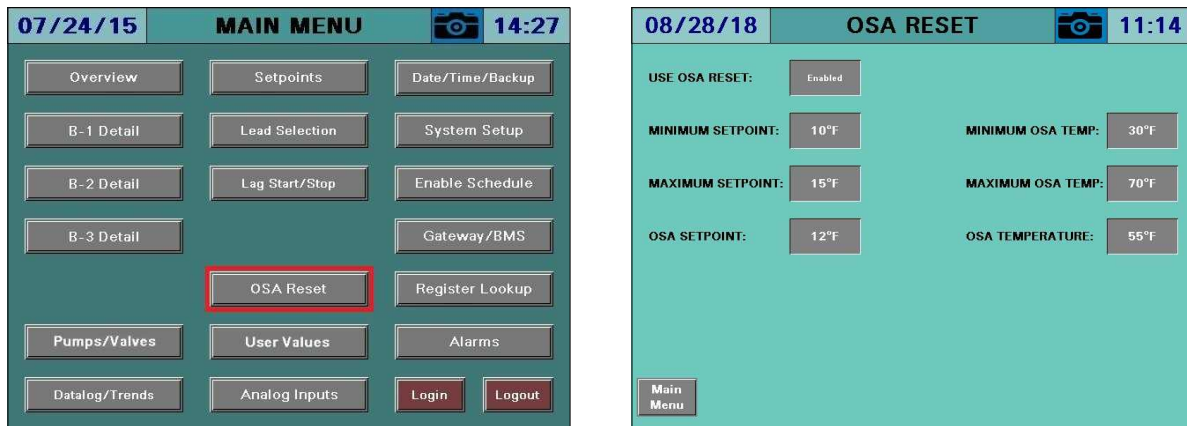

The setpoint can be generated based upon the outside air temperature. The outside air temperature sensor is polled once every five minutes to update the current setpoint (maximum 12 setpoint changes per hour). If the outside air temperature reading is invalid or the sensor becomes inoperative, the default setpoint will be used.

USE OSA RESET – Select whether to use the outside air reset functionality (TECH required).

- **Disabled**
- **Enabled**

MINIMUM, MAXIMUM SETPOINT – Sets the allowable range of the outside air reset setpoint (TECH required).

MINIMUM, MAXIMUM OSA TEMP – Sets the allowable range of the outside air temperatures used to calculate the outside air reset setpoint (TECH required).

OSA SETPOINT – Displays the calculated outside air setpoint. This is a linear calculation based upon the minimum and maximum setpoints and OSA temperatures entered. When the outside air temperature is outside of the minimum and maximum limits, the setpoint will stay at the minimum or maximum as applicable. It will never exceed the entered minimum or maximum.

OSA TEMPERATURE – Displays the current outside air temperature.

Outside Air Reset (continued)

Outside Air Reset Curve Example

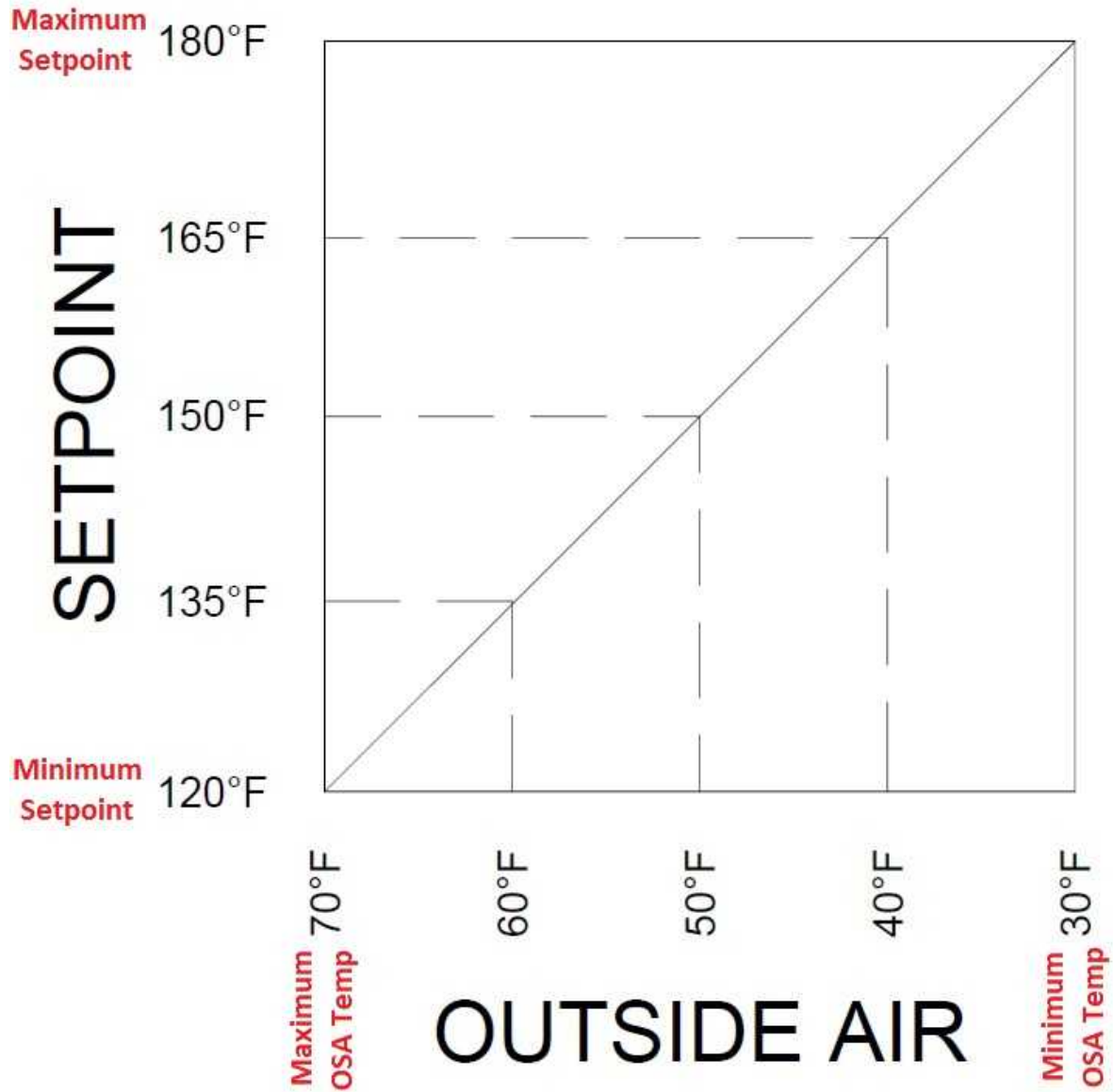

Analog Inputs

Access level: **USER**

The analog inputs screen displays analog input information. From the MAIN MENU screen, press **ANALOG INPUTS**. The ANALOG INPUTS screen will appear.



If totalization is enabled for any of the analog inputs, touching the totalized value > 1s (hold down) will reset the value to 0 (TECH required).

Datalog/Trends

Access level: **USER/TECH/SETUP**

Six trends are available that can record two variables at user-defined intervals. Datalogging up to twelve variables to a USB drive is also available. From the MAIN MENU screen, press **TRENDS** (USER) or **DATALOG/TRENDS** (TECH or SETUP). The TREND 1 or DATALOG screen will appear.



Datalog/Trends (continued)

Trends

Trending data is stored on the SD card, which is supplied as shipped. Data will be stored for the previous 7 days.

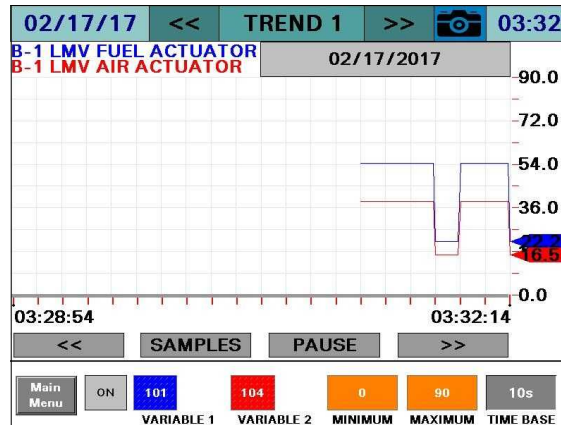

To scroll between the trends, press << and >> beside the title bar.

ON/OFF – Enables or disables the selected trend.

TREND NAVIGATION

- << – Scroll back to view previous trend data. The trend will scroll back by a sample, second, minute, hour, or day depending upon the setting of the **SAMPLES/SECONDS/MINUTES/HOURS/DAYS** button. This will pause the trend display automatically.
- **SAMPLES/SECONDS/MINUTES/HOURS/DAYS** – Sets the scroll range for viewing recorded trend data.
- **PAUSE** – This will pause or play the trend display. 'PAUSED' will display in red text when paused and touching again will restore the trend to the current display.
- >> – Scroll forward when viewing previous trend data. The trend will scroll back by a minute, hour, or day depending upon the setting of the **SAMPLES/SECONDS/MINUTES/HOURS/DAYS** button.

VARIABLES TO LOG (BLUE, RED) – Sets the Modbus register index to trend (TECH required).

MIN, MAX – Sets the range for the trend data (TECH required).

TIME BASE – Select a time base for trending. Choices are 10s, 20s, 30s, 1m, 2m, 5m, 10m, 15m, 30m, 60m (TECH required).

Datalog/Trends (continued)

Datalog

Data can be saved to a USB drive in a text format for viewing in a spreadsheet application. A USB drive must be inserted in order to use datalogging.



LOG VALUES – Sets the Modbus register index to log (TECH required).

ON/OFF – Enables or disables logging the selected value (TECH required).

TIME BASE – Select a time base for logging. Choices are 10s, 20s, 30s, 1m, 2m, 5m, 10m, 15m, 30m, 60m (TECH required).

START LOG/STOP LOG – Enables or disables all logging (TECH required).

RESET – Sets all log values to '0' (TECH required).

TRENDS – Navigates to the TREND 1 screen (TECH required).

The resulting file is in a tab-separated format (.csv) and can be viewed with any text editor or spreadsheet application. On the USB drive, data can be found at:

Path = \PUBLIC\PROJECTS\MASTERxx\DATA\TEXT, xx is 7W for 7", 10 for 10"/12"

Filename = DATALOG_mm_dd_yyyy.CSV (mmdyyy are date)

	A	B	C	D	E	F	G
1	SCC Inc. Lead/Lag Master Datalog						
2	LLM Model: TS-MS10S-U Rev. 15F1						
3	Site: Lead/Lag Master						
4							
5	Date	Time	B-1 LMV CURRENT OUTPUT	B-2 LMV CURRENT OUTPUT	B-3 LMV CURRENT OUTPUT	B-4 LMV CURRENT OUTPUT	B-5 LMV CURRENT OUTPUT
6	9/23/2015	11:02:21	57.9	57.9	57.9	57.9	57.9
7	9/23/2015	11:02:30	62.2	62.2	62.2	62.2	62.2

Register Lookup

Access level: **USER/TECH/SETUP**

Modbus register indices can be looked up using text strings.



Enter a string or register index to search, then press **LOOKUP**.

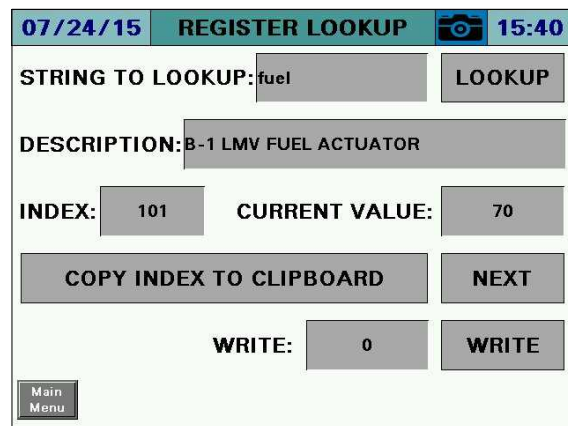
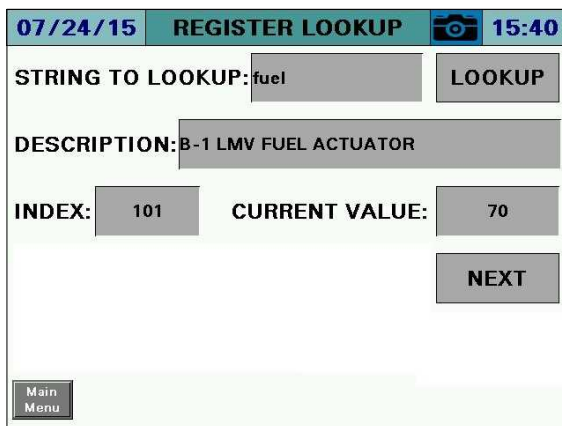

STRING TO LOOKUP – Input the string or register number to search for. Examples are 'FUEL' or '12' (would display the description of index 12).

DESCRIPTION – Displays the full name of the register containing the search string.

INDEX – Displays the index of the register that matches the description.

CURRENT VALUE – Displays the current value of the register. This is a raw value (not scaled).

COPY INDEX TO CLIPBOARD – Copies the register index and matching divider to the clipboard. This can be pasted into monitored output, trend, or datalog configuration (TECH required).

NEXT – Scroll to the next register index matching the description. 'END OF LIST REACHED' will display if there are no more matching descriptions.

WRITE – Sets the value to manually write to a register. This can be used to test functionality such as remote setpoint or enables. Press **WRITE** to apply value (TECH required).

Register Lookup (continued)

Using the Clipboard

If there is data in the clipboard, the configuration screens for the monitored outputs, trends and the datalog will have corresponding buttons that can be used to paste the data.

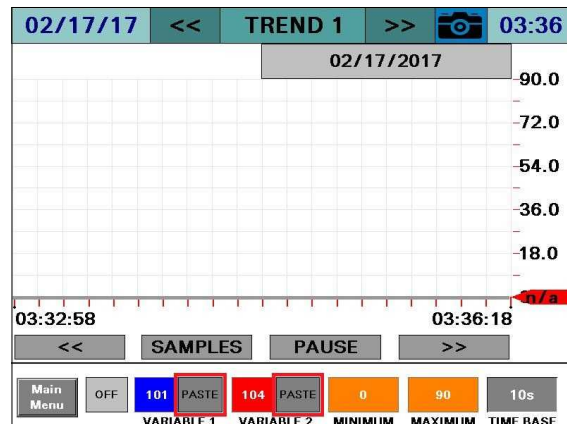
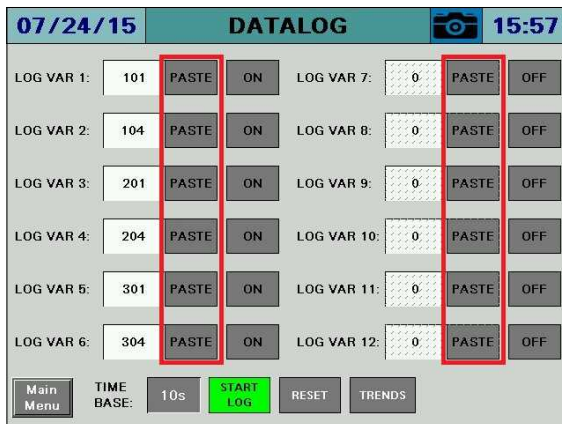
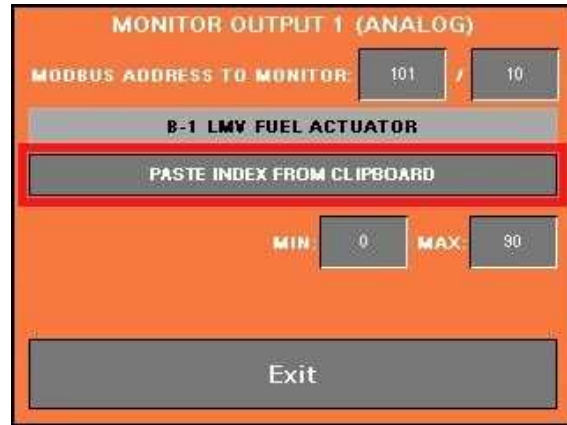
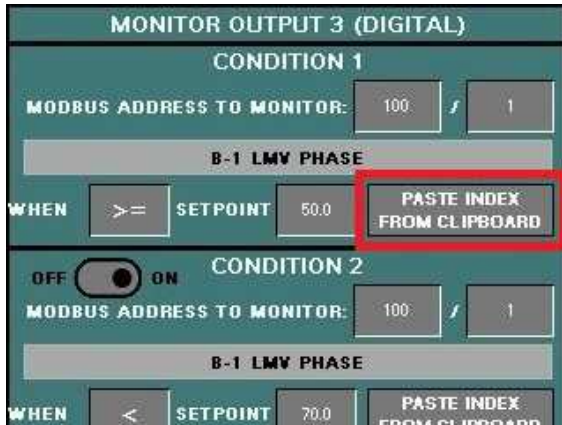

User Values

Access level: **SETUP**

There are 16 general-purpose Modbus registers available for assignment to any other Modbus value. These can be used to consolidate the Modbus data into a continuous block. An option also exists to run text scripts for custom data manipulation and display.



MODE – Selects the source of the user value data.

- **Modbus:** Enter the Modbus address of the desired data.
- **Script:** Runs the scripts present on the SD card. See *Creating User Value Scripts* for additional detail.

TIME BASE – Sets the duration that the user value data is updated.

Loading User Value Scripts

To load user value scripts, change the MODE variable to "Script". This will change the user values function to run scripts. This screen will also show the results of calculated user value scripts. Press **Manage** for > 2s (hold down) to display the management screen (OEM required).



User Values (continued)

If a USB drive is inserted with valid user value script files, press the USB icon for the corresponding value to load from the USB drive. The script will load and immediately begin running, displaying a green check mark to indicate success. Scripts are not loaded if a red "X" is displayed after the script name.

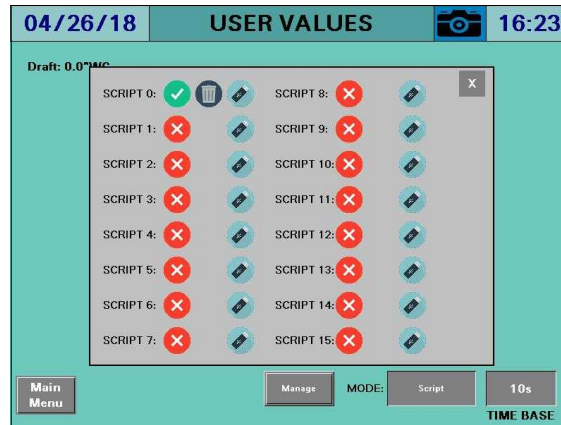

Loaded scripts can be deleted by pressing the trash icon.

Alarms

Access level: **USER**

Alarms are displayed on a dedicated alarm screen. The last 100 alarms are stored in memory and time stamped. When an alarm is present, a link to the alarm screen will flash over the title bar of the OVERVIEW screen. The ALARMS screen also displays the revision number of the PLC and the HMI.

To access the alarm screen from the main menu, press **ALARMS**. The ALARMS screen will appear.







The ALARMS screen lists current alarms as well as older alarms. The color of the alarm indicates the category of the alarm:

- **Red** – LMV lockouts. The text flashes when the alarm is currently active.
- **Orange** – LMV faults.
- **Yellow/Green** – Communication faults. The background is yellow when the alarm is currently active and green when communication is present.
- **Blue** – All other alarms such as analog alarms, pump alarms, and expanded annunciator alarms. The text flashes when the alarm is currently active.

Information about the most recent alarms will be displayed with the following information:

- **No.** – Number of the alarm in the list (1 is most recent).
- **Date** – Displays the date that the alarm occurred.
- **Active** – Displays the time when the alarm became active.
- **Cleared** – Displays the time when the alarm was cleared.

The icons at the top of the screen may be used to navigate through the list of alarms:

-  Move up one alarm on the list.
-  Move down one alarm on the list.
-  Navigate up one page on the list.
-  Navigate down one page on the list.

Date/Time/Defaults

Access level: **TECH/SETUP**

The Lead/Lag Master will automatically synchronize the date and time with any connected LMV5 controllers and/or Touchscreen Kits.

Setpoint, lead selection, lag start/stop and other operating data can be saved in profiles for backup or quick change purposes. For example, separate profiles for summer and winter could be created if needed.

To access the date/time/defaults screen from the main menu, press **DATE/TIME/DEFAULTS**. The DATE/TIME/DEFAULTS screen will appear.



Setting Date/Time

To change the date and time, enter the desired values and press **ENTER** to apply. The system will then update the date and time. Any datalogging or trending that is currently in operation will reset whenever the date and time are changed to maintain continuity.

System Settings

System settings can be saved to a file (.csv) for archiving and migrating settings. Up to 999 backup files can be saved. Choose between the internal SD card or an external USB drive in the **Backup Destination** field. To load a file, specify the file number in the **Backup File Number** field and then press **RESTORE**. If a valid backup file is present with that number, it will load all of the system settings. To save a file, assign a backup file number and a backup file name in the **Backup File Name** field and then press **SAVE**. The save process may take a few seconds to complete. If using an external USB drive it is best to leave that inserted for an additional five seconds after the operation has completed to ensure that everything is successfully saved. An error will appear if an external USB drive is specified but not inserted or if the specified file is not present.

If an implausible value is specified for any parameter, an error message will appear to indicate that one or more values were invalid. Any remaining valid parameters will continue to load.

Date/Time/Defaults (continued)

The resulting file is in a tab-separated format (.csv) and can be viewed with any text editor or spreadsheet application. On the USB drive, data can be found at:

Path = \PUBLIC\PROJECTS\MASTERxx\DATA\TEXT, xx is 7W for 7", 10 for 10"/12"

Filename = LLMSETUP_xxx.CSV (xxx is the backup file number)

	A	B
1	SCC Lead/Lag Master System Configuration	
2	//Setup	
3	NUMBER	1
4	NAME	Default
5	SITE	Lead/Lag Master
6	SSTYPE	0
7	SSTIME	60
8	LOGOUTTIME	60
9	QUANTITY	5
10	CONNMETB1	0
11	CONNMETB2	1

Restore Factory Defaults

System settings can be restored to the factory default settings. This is without site configuration (as the panel was shipped). Choose **Default** in the **Backup Destination** field, then press **RESTORE**.

Date/Time/Defaults (continued)

Email Settings

Email settings can be saved to a file (.txt) for archiving and migrating settings. Up to six email addresses can be entered. If an email address is not used, enter 'none'. Press **SAVE** to save the existing settings or press **RESTORE** to restore the saved settings. Email will be automatically enabled for any valid entries.

The resulting file is a text file (.txt) and can be viewed with any text editor. On the USB drive, data can be found at:

Path = \PUBLIC\PROJECTS\MASTERxx\DATA\TEXT, xx is 7W for 7", 10 for 10"/12"

Filename = EMAIL.TXT

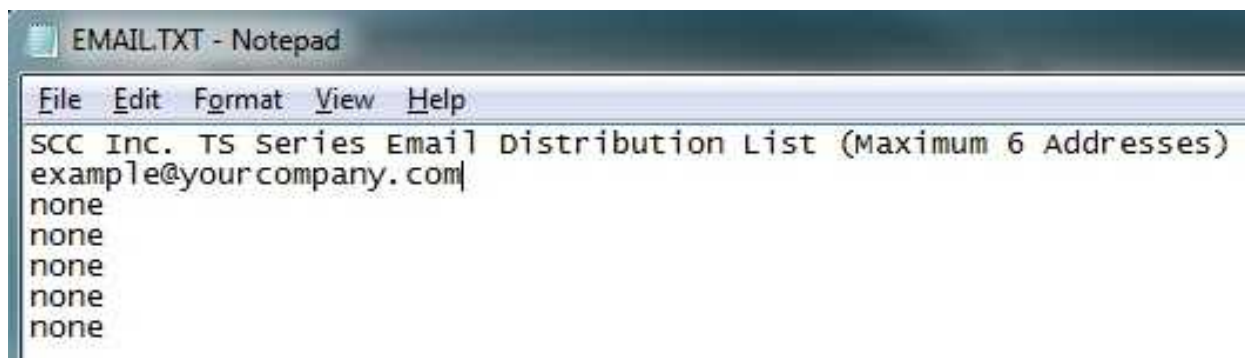

Enable Schedule

Access level: **TECH/SETUP**

The Lead/Lag Master can be programmed with a schedule to enable/disable the system or change setpoints as desired. When enabled, the system will use this schedule whenever the system is in remote mode. Note that when the enable schedule is used, no other source of remote setpoint and enable (such as BMS) can be used other than the digital REMOTE DISABLE input.

To access the enable schedule screen from the main menu, press **ENABLE SCHEDULE**. The ENABLE SCHEDULE screen will appear.

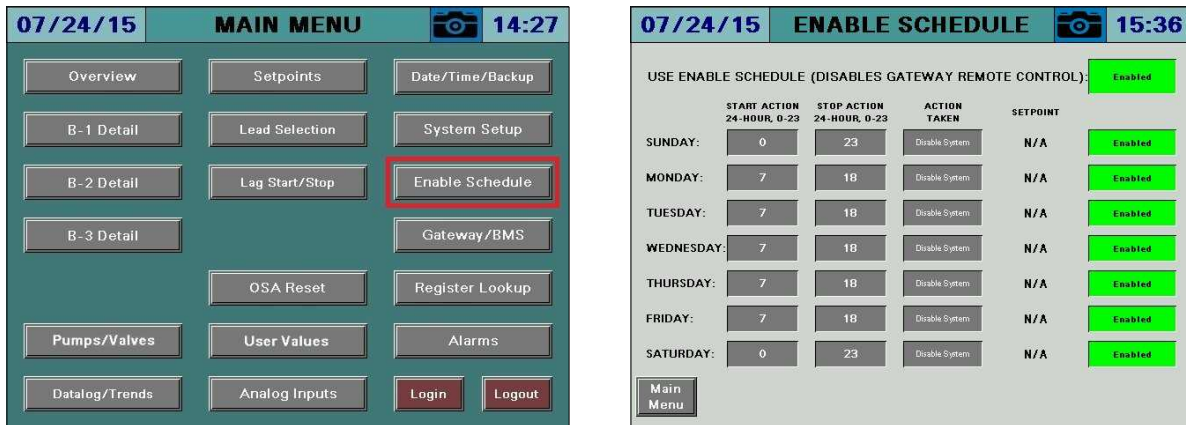

USE ENABLE SCHEDULE – Enables or disables the schedule function.

START ACTION BY DAY OF WEEK – Sets the starting hour for the action in 24-hour format.

STOP ACTION BY DAY OF WEEK – Sets the ending hour for the action in 24-hour format.

The action is active when the time is between the start (inclusive) and stop (inclusive). For example, if the start hour is 7 and the stop hour is 18, the action is active from 07:00 until 18:59.

ACTION TAKEN – Selects which action to take when active.

- **DISABLE SYSTEM** – Sets the system from enabled to disabled.
- **ENABLE SYSTEM** – Sets the system from disabled to enabled.
- **CHANGE SP DURING ACTION** – Sets the system to use the entered setpoint.
- **CHANGE SP OUTSIDE ACTION** – Sets the system to use the entered setpoint only when the action is not active.

SETPOINT – Sets the desired remote setpoint to use when a change setpoint action is selected.

ENABLE DAILY ACTION – Enables or disables the schedule function for the selected day of week.

Using External USB Drive

Access level: **USER**

A USB drive can be used to save screen captures, datalog files, and for saving or loading backup files. A display reading 'The USB device is connected.' will appear to confirm that the USB drive is ready to use.

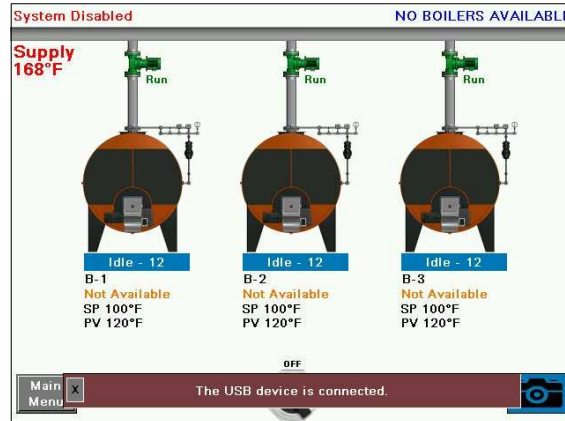

Once removed, the display will read 'The USB device is unplugged.'

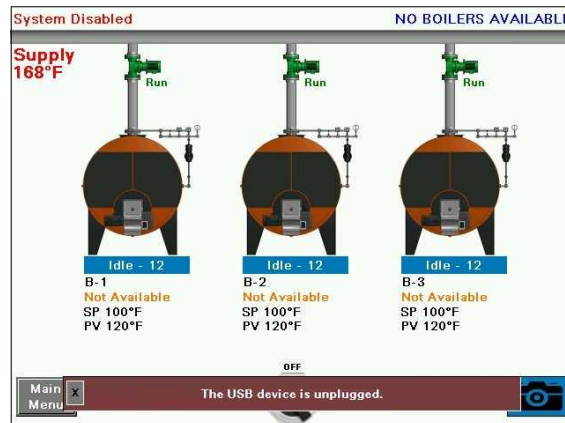

Saving Screen Captures

Access level: **USER**

The current screen image may be copied to a USB drive. Any screen may be captured by pressing the camera icon > 5s (hold down) until the screen displays 'SNAPSHOT SAVED TO USB'.

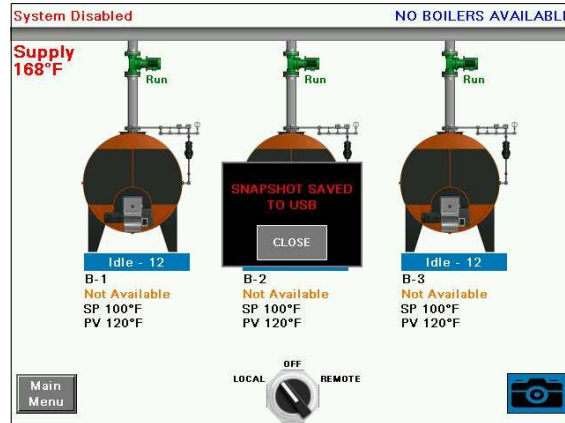

If there is no USB drive inserted or there is an error while trying to save the snapshot, a message will display saying 'SNAPSHOT SAVE ERROR'.

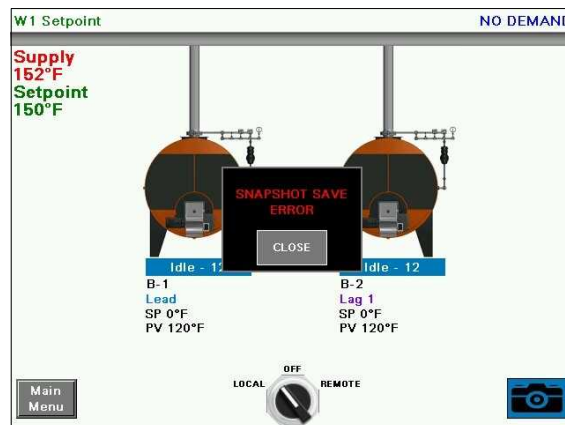

Saving Screen Captures (continued)

If email is configured, an email containing the screen capture as an attachment can be sent by pressing **EMAIL**. Note that screen captures always require a USB drive to be inserted, even to send an email.

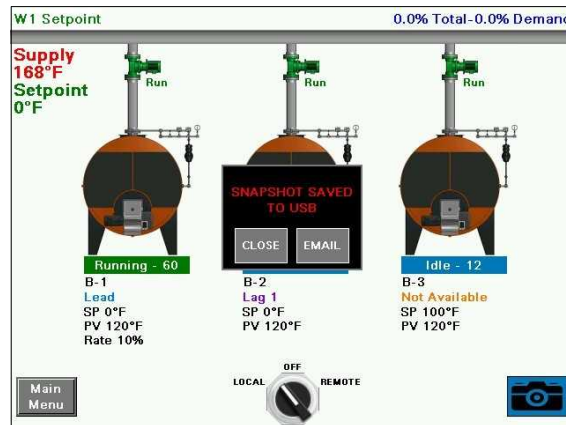

There is no limit to the number of screen captures that may be saved to the USB drive other than the capacity of the USB drive itself. Saved images may be viewed or deleted by going to the SAVED IMAGES screen accessible from the SYSTEM SETUP screen.

Changing Passwords

Access level: **SETUP**

By default, the TECH access level password is 9876 and the SETUP access level password is START. These default passwords may be changed at any time. To change passwords, press **LOGIN** from the main menu. Enter the appropriate information to log in at the SETUP access level and press **APPLY**. The CURRENT USER will change to SETUP.

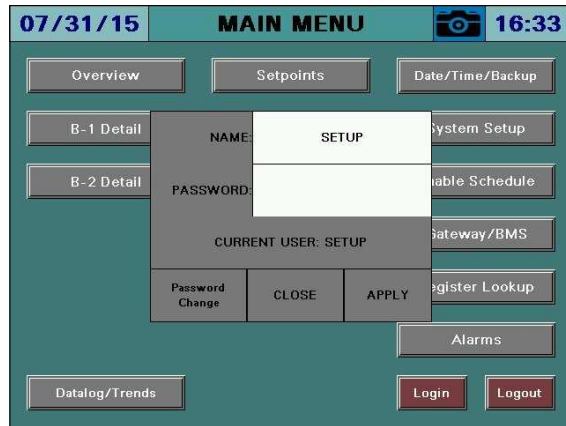
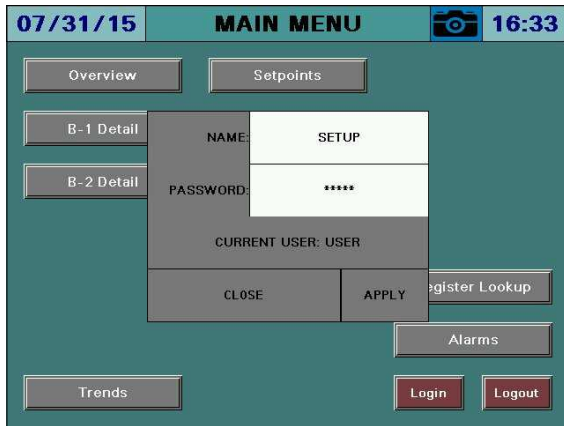

After that is done, press **PASSWORD CHANGE**.

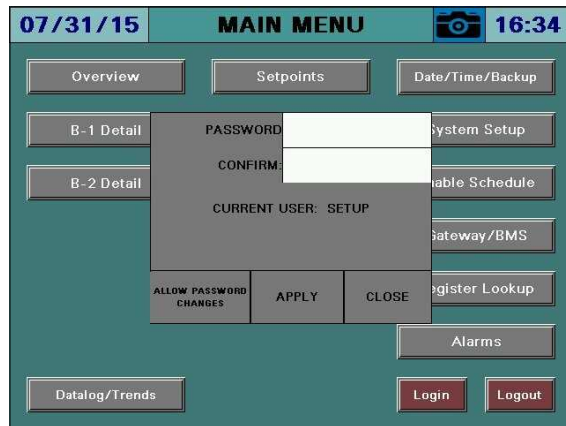
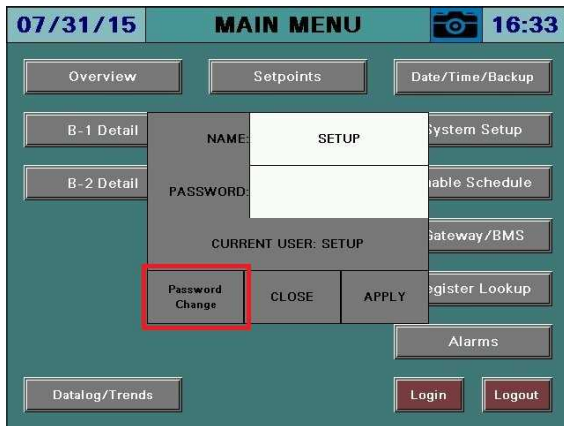

Changing Passwords (continued)

The SETUP password may be changed from this screen. Enter the new password twice and press **APPLY** to make the change. To allow the TECH user access to change the TECH password, press **ALLOW PASSWORD CHANGES**.

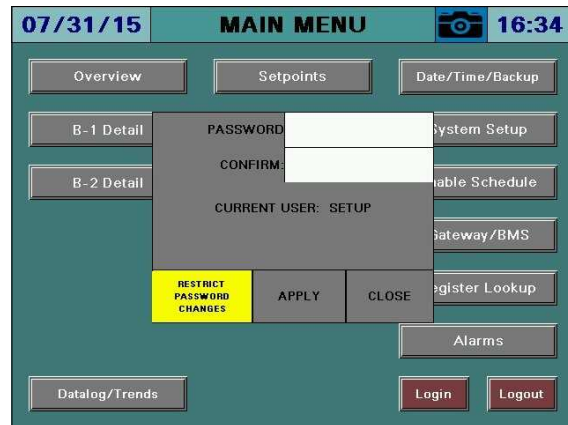
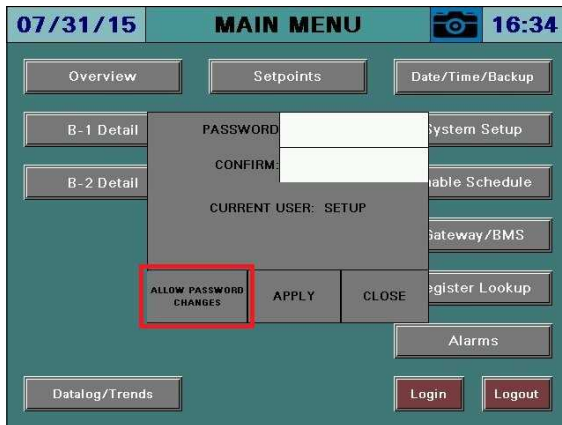

If password changes have been allowed, the TECH user may now change their password by following the same procedure as described above for the SETUP user. To disallow the TECH user from changing the TECH password, press **RESTRICT PASSWORD CHANGES**.

Gateway/BMS

Access level: **TECH/SETUP**

The Lead/Lag Master has two available ports (RS-485 or Ethernet) that can be used for BMS communication via Modbus. Both ports are simultaneously active and can be used.

The following additional protocols are available with a TS Series Protocol Converter (see *Document No. TS-6100* for additional detail):

- BACnet/IP
- BACnet MS/TP
- Metasys N2
- Ethernet/IP
- Lonworks

To access the gateway screen from the main menu, press **GATEWAY/BMS**. The GATEWAY/BMS screen will appear.

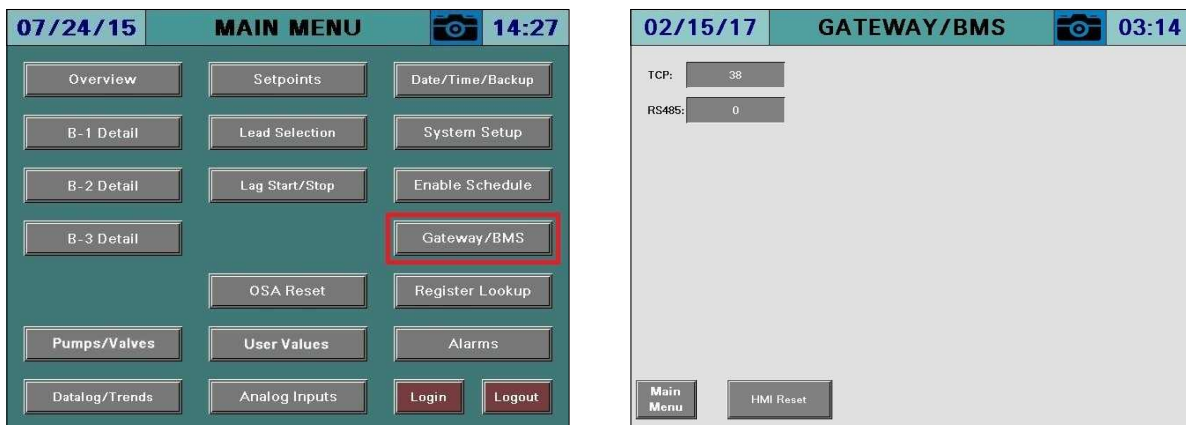

Incoming communication statistics for each of the interfaces are shown. Holding down the value for > 1s (hold down) will reset that interface's statistics to zero.



If a TS Series Protocol Converter is connected, 'EXTERNAL GATEWAY CONNECTED' will appear. The configured protocol and version is also displayed.

Gateway/BMS (continued)

Additional Options

Additional options exist in the lead/lag master that can be activated if needed. This can be done through the Modbus TCP/IP connection or through the TS Series Protocol Converter.

The additional options are all activated from a single word, Modbus address 27 (LLM EXTRA OPTIONS). Each option is represented as a bit. To write bits, take the sum of their decimal values (bit 0 = 1, bit 1 = 2, bit 2 = 4, and bit 3 = 8). For example, to write bits 0 and 2, the sum would be 5 and this would be written to Modbus address 27.

Disable Watchdog Timer

Bit = 0 (decimal value 1)

Normally, using a BMS connection to provide a remote enable or setpoint requires that the signal is refreshed on a regular interval. This is called a watchdog timer. If this is not done, the lead/lag master will revert to running on the local setpoint. This is known as 'fail to heat' mode. If the BMS system cannot work with the watchdog timer or if it is not otherwise desired, it can be disabled with this bit. If this is done, the GATEWAY/BMS screen on the lead/lag master will display 'EXTERNAL WATCHDOG DISABLED BY USER OPTION'. Note that if this action is taken, a loss of communication with the BMS will result in the last commanded option remaining in effect until a power cycle or until communication is re-established.

Outside Air Temperature from BMS

Bit = 1 (decimal value 2)

If an outside air temperature sensor is connected it can be used to implement an outside air setpoint reset (hydronic systems only) or a warm-weather shutdown. Normally this sensor is connected to an analog or RTD input. If this bit is enabled, the system will take the outside air temperature from Modbus address 17 (LLM EXTRA INPUT). The value written must be 120°F or less in order to be considered valid.

Direct Control of Lead Boiler

Bit = 2 (decimal value 4)

If this bit is set, the BMS can control the lead boiler selection by writing to Modbus address 3 (LLM LEAD BOILER). This converts that address from read-only to read/write. The lead mode selected does not matter when direct BMS control is selected. When active, the LEAD SELECTION screen will display 'AUTOMATIC ALTERNATION CONTROLLED BY GATEWAY'. Note that if a boiler that isn't available is selected as lead this can cause system issues since the lead boiler will not be able to run. The total number of available boilers as well as individual boiler available statuses can be checked via Modbus.

Gateway/BMS (continued)

Direct Control of Load Demand

Bit = 3 (decimal value 8)

If this bit is set, the BMS can control the load demand directly by writing to Modbus address 26 (LLM LOAD DEMAND). This converts that address from read-only to read/write. The modulation mode still applies for sequencing when direct BMS control is selected. When active, the SYSTEM OVERVIEW screen will display 'GATEWAY xxx% DEMAND'. The BMS demand is in the format of 0-100% and must be in this range to be valid. This will be translated into the percent of total demand. For example, if there are three boilers (maximum demand of 300%), a BMS demand of 50% will equal 150% for the purposes of lag start/stop points.

Setting Options via TS Series Protocol Converter

To apply these options to the TS Series Protocol Converter, enter the calculated word value for the desired options onto the web configuration page in the option labeled 'other_option'. After the value is entered, click 'Submit'. There will be a corresponding BMS point for 'LLM EXTRA INPUT', 'LLM LEAD BOILER' and 'LLM LOAD DEMAND' to write the control data to.

The screenshot shows the web configuration page for the SCC Inc. Universal Gateway. The page is titled 'app/profiles/profiles.htm' and is accessed via the URL '192.168.1.70/app/profiles/profiles.htm'. The page contains several configuration options, each with a text input field and a 'Submit' button:

- bac_ip_port**: BACnet/IP Port. This sets the BACnet/IP port of the Gateway. The default is 47808. (1 - 65535). Value: 47808.
- network_number**: BACnet Network Number. This sets the BACnet network number of the Gateway. (1 - 65535). Value: 50.
- bac_cov_option**: BACnet COV. This enables or disables COVs for the BACnet connection. Use COV_Enable to enable. Use COV_Disable to disable. (COV_Enable/COV_Disable). Value: COV_Disable.
- bac_bbmd_option**: BACnet/IP BBMD. This enables BBMD on the BACnet/IP connection. Use BBMD to enable. Use - to disable. The bdt.ini files also needs to be downloaded. (BBMD/-). Value: -.
- ip_master**: IP Address Lead-Lag Master. This is the IP address for the lead-lag master. (xxx.xxx.xxx.xxx). Value: 192.168.1.69.
- watchdog_time**: Watchdog Time. Remote commands must be refreshed within this time. (0 - 999). Value: 60.
- other_option**: Additional Option Codes. Use as specified for additional options. (0 - 999). Value: 0. This field is highlighted with a red box.

Below the configuration options is an 'Active profiles' section with a table:

Nr	Node ID	Current profile	Parameters
Add			

At the bottom of the page, there are several navigation buttons: HELP (?), Network Settings, Clear Profiles and Restart, System Restart, and Diagnostics & Debugging.

Gateway/BMS (continued)

Changing Serial Port Parameters

To change the serial port parameters, the HMI CONFIGURATION screen must first be accessed. Navigate to **MAIN MENU**, then **SYSTEM SETUP**.

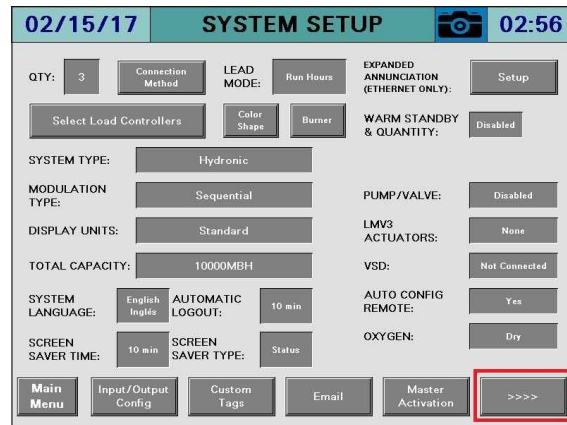

Press the >>>> then press the **HMI CONFIGURATION** button. Once the HMI CONFIGURATION screen is displayed, press the **OFFLINE** tab.

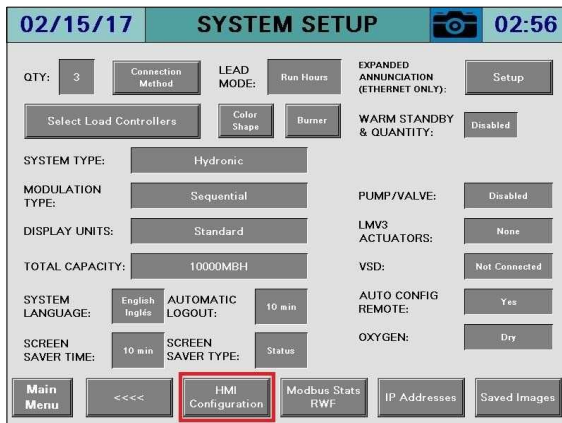

Gateway/BMS (continued)

Once the OFFLINE tab is displayed, press **IO MANAGER**. A warning will appear that the application must pause while the IO MANAGER screen is accessed. Press **OK** to acknowledge this warning.



The screen will reboot into the IO MANAGER screen. Press **EQUIPMENT CONFIG** to change the serial port parameters. Choose 'Converter' from the drop-down menu. This will modify COM1 (RS-485). Use the up/down arrows to scroll between the three pages of configuration, then press **OK** when finished. Note that the nomenclature used for the Modbus slave/node number is 'Equipment Address'. From the IO MANAGER screen, press **RETURN**, then from the OFFLINE tab press **TO RUN MODE** to reboot the application.

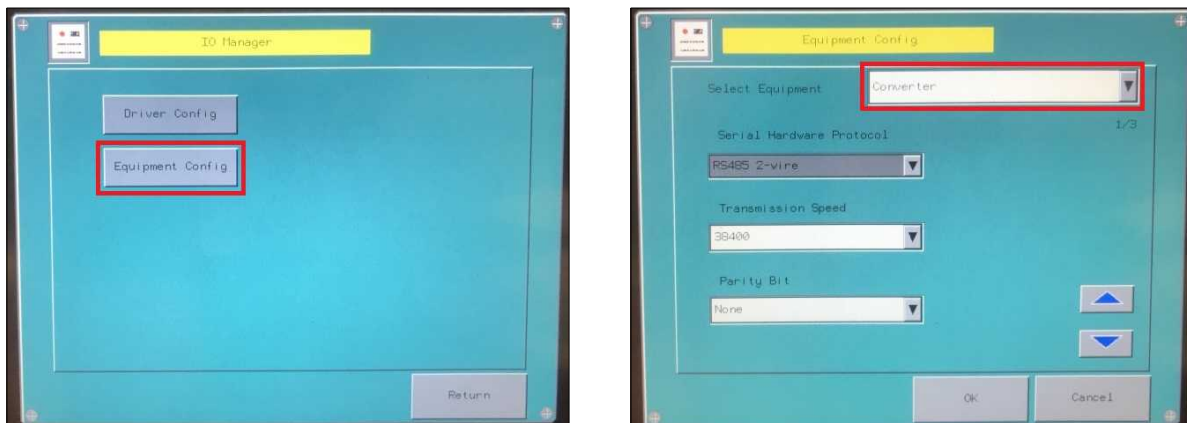

Gateway/BMS (continued)

Serial Port Wiring Interface

If the desired serial port is not broken out into a terminal strip interface, it can still be used if connected directly to the desired touchscreen COM port.

COM1 (RS-485)

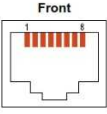
Pin Connection	Pin No.	RS-485		
		Signal Name	Direction	Meaning
	1	NC	-	-
	2	NC	-	-
	3	NC	-	-
	4	Line A	Input/Output	Transfer Data (RS-485)
	5	Line B	Input/Output	Transfer Data (RS-485)
	6	RS(RTS)	Output	Request To Send
	7	NC	-	-
	8	SG	-	Signal Ground

Notes on using COM1:

- Data+ / RS485+ / A on pin 4 (blue on typical Cat5 Ethernet cable)
- Data- / RS485- / B on pin 5 (white/blue on typical Cat5 Ethernet cable)
- Common ground on pin 8 (brown on typical Cat5 Ethernet cable, may be required)
- Some equipment refers to Data+ and Data- differently. Change the polarity of the connection as a first test if communication cannot be established.

Gateway/BMS (continued)

Modbus Mapping

The addresses shown are 0-based (begin at 0) and are in decimal format.

Supported function codes:

FC3 (read holding registers), address 0 = 40001.

FC4 (read input registers), address 0 = 30001.

FC6 (single register write), address 0 = 40001.

FC16 (multiple register write), address 0 = 40001.

Addresses with access R are read-only, access RW are read-write.

Modbus addresses designated as 'x00' through 'x99' are common to all connected boilers. Substitute the boiler number for the 'x'. For example, Modbus address 'x12' would equal Modbus address '112' for boiler 1, '212' for boiler 2, etc.

Gateway/BMS – Mapping (Global System Data)

Modbus Mapping – Global System Data

ADDRESS	ACCESS	DESCRIPTION	FORMAT	NOTES
0	RW	LLM REMOTE ENABLE	Unsigned Int 16	0=off,1=enabled
1	RW	LLM REMOTE VALID	Unsigned Int 16	0=invalid,1=valid
2	RW	LLM REMOTE SETPOINT	Unsigned Int 16	
3	RW	LLM LEAD BOILER	Unsigned Int 16	
4	R	LLM ALTERNATION SETPOINT	Unsigned Int 16	
5	R	LLM ALT HOURS REMAINING	Unsigned Int 16	
6	R	LLM CURRENT SETPOINT	Unsigned Int 16	
7	R	LLM TOTAL AVAILABLE	Unsigned Int 16	
8	R	LLM ACTUAL VALUE	Unsigned Int 16	
9	R	LLM RTD 1	Unsigned Int 16	x10
10	R	LLM RTD 2	Unsigned Int 16	x10
11	R	LLM RTD 3	Unsigned Int 16	x10
12	R	LLM RTD 4	Unsigned Int 16	x10
13	R	LLM ANALOG INPUT 1 U16	Unsigned Int 16	
14	R	LLM ANALOG INPUT 2 U16	Unsigned Int 16	
15	R	LLM ANALOG INPUT 3 U16	Unsigned Int 16	
16	R	LLM ANALOG INPUT 4 U16	Unsigned Int 16	
17	RW	LLM EXTRA INPUT	Unsigned Int 16	
18	R	LLM ANALOG INPUT 1 FLOAT	Float 32	
20	R	LLM ANALOG INPUT 2 FLOAT	Float 32	
22	R	LLM ANALOG INPUT 3 FLOAT	Float 32	
24	R	LLM ANALOG INPUT 4 FLOAT	Float 32	
26	RW	LLM LOAD DEMAND	Unsigned Int 16	x10
27	RW	LLM EXTRA OPTIONS	Unsigned Int 16	
28	R	LLM ANALOG INPUT 1 TOTALIZED	Unsigned Int 32	x10
30	R	LLM ANALOG INPUT 2 TOTALIZED	Unsigned Int 32	x10
32	R	LLM ANALOG INPUT 3 TOTALIZED	Unsigned Int 32	x10
34	R	LLM ANALOG INPUT 4 TOTALIZED	Unsigned Int 32	x10
36	R	LLM MONITOR OUT 1 U16	Unsigned Int 16	x10
37	R	LLM MONITOR OUT 2 U16	Unsigned Int 16	x10
38	R	LLM MONITOR OUT STATUS	Unsigned Int 16	
38 bit 0	R	LLM MONITOR OUT 3	Boolean	
38 bit 1	R	LLM MONITOR OUT 4	Boolean	
38 bit 2	R	LLM MONITOR OUT 5	Boolean	
38 bit 3	R	LLM MONITOR OUT 6	Boolean	
39	R	LLM ANALOG ALARM STATUS	Unsigned Int 16	
39 bit 0	R	LLM LOW ALARM AI 1	Boolean	
39 bit 1	R	LLM HIGH ALARM AI 1	Boolean	
39 bit 2	R	LLM LOW ALARM AI 2	Boolean	
39 bit 3	R	LLM HIGH ALARM AI 2	Boolean	
39 bit 4	R	LLM LOW ALARM AI 3	Boolean	
39 bit 5	R	LLM HIGH ALARM AI 3	Boolean	
39 bit 6	R	LLM LOW ALARM AI 4	Boolean	
39 bit 7	R	LLM HIGH ALARM AI 4	Boolean	
40	R	LLM RTD ALARM STATUS	Unsigned Int 16	
40 bit 0	R	LLM LOW ALARM RTD 1	Boolean	
40 bit 1	R	LLM HIGH ALARM RTD 1	Boolean	
40 bit 2	R	LLM LOW ALARM RTD 2	Boolean	

Modbus Mapping – Global System Data

ADDRESS	ACCESS	DESCRIPTION	FORMAT	NOTES
40 bit 3	R	LLM HIGH ALARM RTD 2	Boolean	
40 bit 4	R	LLM LOW ALARM RTD 3	Boolean	
40 bit 5	R	LLM HIGH ALARM RTD 3	Boolean	
40 bit 6	R	LLM LOW ALARM RTD 4	Boolean	
40 bit 7	R	LLM HIGH ALARM RTD 4	Boolean	
41	R	LLM OTHER STATUS	Unsigned Int 16	
41 bit 0	R	LLM COMM FAULT BOILER 1	Boolean	
41 bit 1	R	LLM COMM FAULT BOILER 2	Boolean	
41 bit 2	R	LLM COMM FAULT BOILER 3	Boolean	
41 bit 3	R	LLM COMM FAULT BOILER 4	Boolean	
41 bit 4	R	LLM COMM FAULT BOILER 5	Boolean	
41 bit 5	R	LLM COMM FAULT BOILER 6	Boolean	
41 bit 6	R	LLM COMM FAULT BOILER 7	Boolean	
41 bit 7	R	LLM COMM FAULT BOILER 8	Boolean	
41 bit 8	R	LLM ALARM MON OUT 3	Boolean	
41 bit 9	R	LLM ALARM MON OUT 4	Boolean	
41 bit 10	R	LLM ALARM MON OUT 5	Boolean	
41 bit 11	R	LLM ALARM MON OUT 6	Boolean	
41 bit 12	R	LLM COMM FAULT PLC	Boolean	
41 bit 13	R	LLM GENERAL ALARM	Boolean	
42	R	LLM DIGITAL INPUTS	Unsigned Int 16	
42 bit 0	R	LLM DIGITAL INPUT 1	Boolean	
42 bit 1	R	LLM DIGITAL INPUT 2	Boolean	
42 bit 2	R	LLM DIGITAL INPUT 3	Boolean	
42 bit 3	R	LLM DIGITAL INPUT 4	Boolean	
42 bit 4	R	LLM DIGITAL INPUT 5	Boolean	
42 bit 5	R	LLM DIGITAL INPUT 6	Boolean	
49	R	LLM WEEKDAY	Unsigned Int 16	0=Sun,1=Mon,...,6=Sat
50	R	LLM YEAR 2-DIGIT	Unsigned Int 16	
51	R	LLM MONTH	Unsigned Int 16	
52	R	LLM DAY	Unsigned Int 16	
53	R	LLM HOUR	Unsigned Int 16	
54	R	LLM MINUTE	Unsigned Int 16	
55	R	LLM SECOND	Unsigned Int 16	
56	RW	FREE REGISTER	Unsigned Int 16	
57	RW	FREE REGISTER	Unsigned Int 16	
58	RW	FREE REGISTER	Unsigned Int 16	
59	RW	FREE REGISTER	Unsigned Int 16	
60	R	USER VALUE 1	Unsigned Int 16	see Note 3 below
61	R	USER VALUE 2	Unsigned Int 16	see Note 3 below
62	R	USER VALUE 3	Unsigned Int 16	see Note 3 below
63	R	USER VALUE 4	Unsigned Int 16	see Note 3 below
64	R	USER VALUE 5	Unsigned Int 16	see Note 3 below
65	R	USER VALUE 6	Unsigned Int 16	see Note 3 below
66	R	USER VALUE 7	Unsigned Int 16	see Note 3 below
67	R	USER VALUE 8	Unsigned Int 16	see Note 3 below
68	R	USER VALUE 9	Unsigned Int 16	see Note 3 below
69	R	USER VALUE 10	Unsigned Int 16	see Note 3 below
70	R	USER VALUE 11	Unsigned Int 16	see Note 3 below

Modbus Mapping – Global System Data

ADDRESS	ACCESS	DESCRIPTION	FORMAT	NOTES
71	R	USER VALUE 12	Unsigned Int 16	see Note 3 below
72	R	USER VALUE 13	Unsigned Int 16	see Note 3 below
73	R	USER VALUE 14	Unsigned Int 16	see Note 3 below
74	R	USER VALUE 15	Unsigned Int 16	see Note 3 below
75	R	USER VALUE 16	Unsigned Int 16	see Note 3 below
80	RW	LLM LOOP SETPOINT	Unsigned Int 16	x10
81	R	LLM LOOP OUTPUT PERCENT	Unsigned Int 16	x10
82	RW	LLM LOOP P-VALUE	Unsigned Int 16	x10
83	RW	LLM LOOP I-VALUE	Unsigned Int 16	x10
84	RW	LLM LOOP D-VALUE	Unsigned Int 16	x10
85	RW	LLM LOOP ALT SETPOINT MINS	Unsigned Int 16	
86	R	LLM LOOP ALT ELAPSED MINS	Unsigned Int 16	
87	R	LLM LOOP LEAD PUMP	Unsigned Int 16	
88	RW	LLM LOOP HYSTERESIS ON	Signed Int 16	x10
89	RW	LLM LOOP HYSTERESIS OFF	Signed Int 16	x10
90	R	LLM LOOP OUTPUTS STATUS	Unsigned Int 16	
90 bit 0	R	LLM LOOP OUTPUT 1	Boolean	
90 bit 1	R	LLM LOOP OUTPUT 2	Boolean	
90 bit 2	R	LLM LOOP PUMP 1 RUN	Boolean	
90 bit 3	R	LLM LOOP PUMP 2 RUN	Boolean	
90 bit 4	R	LLM LOOP PUMP 1 ALARM	Boolean	
90 bit 5	R	LLM LOOP PUMP 2 ALARM	Boolean	
91	R	LLM LOOP PUMP 1 CURRENT	Unsigned Int 16	x10
92	R	LLM LOOP PUMP 2 CURRENT	Unsigned Int 16	x10
93	R	LLM LOOP PUMP 1 FREQUENCY	Unsigned Int 16	x10
94	R	LLM LOOP PUMP 2 FREQUENCY	Unsigned Int 16	x10
990	R	LLM SOFTWARE MODEL STRING	String (5 words)	
995	R	LLM SOFTWARE VERSION STRING	String (2 words)	

Gateway/BMS – Mapping (Global System Data) (continued)

Remote Control Strategies

A remote setpoint can be sent to **LLM REMOTE SETPOINT**. The value sent will be displayed on the SETPOINTS screen. In order for this setpoint to be used, the System Local-Off-Remote switch must be in 'Remote' and at least one boiler must be available. The value of **LLM REMOTE ENABLE** must be **1**. This is the value that will toggle the enabled state. The enabled state is also shown on the SETPOINTS screen as '**REMOTE ENABLED**' or '**REMOTE DISABLED**'. The value of **LLM REMOTE VALID** must be actively written to **1** (at least once every 30 seconds). This is a heartbeat to indicate that the BMS is still connected. If **LLM REMOTE VALID** is not written in the appropriate time the system will revert to being enabled as if it were in 'Local' mode. The status of **LLM REMOTE VALID** is shown on the SETPOINTS screen as '**REM OK**' or '**INVALID**'.

Gateway/BMS – Mapping (Boiler Data)

Note that 'x' in the address represents the boiler number. For example, 'x00' is 100 for B-1 and 200 for B-2, etc.

LMV = LMV3... or LMV5... controller data

RWF LC = RWF10 or RWF55 load controller data

FEEDWATER = RWF55 feedwater controller data

EA = Expanded Annunciator data

Modbus Mapping – Boiler Data

ADDRESS	ACCESS	DESCRIPTION	FORMAT	NOTES
x00	R	LMV PHASE	Unsigned Int 16	see LMV Phases
x01	R	LMV FUEL ACTUATOR	Signed Int 16	x10
x02	R	LMV GAS ACTUATOR	Signed Int 16	x10
x03	R	LMV OIL ACTUATOR	Signed Int 16	x10
x04	R	LMV AIR ACTUATOR	Signed Int 16	x10
x05	R	LMV AUX1 ACTUATOR	Signed Int 16	x10
x06	R	LMV AUX2 ACTUATOR	Signed Int 16	x10
x07	R	LMV AUX3 ACTUATOR	Signed Int 16	x10
x08	R	LMV VSD OUTPUT	Unsigned Int 16	x10
x09	R	LMV CURRENT FUEL	Unsigned Int 16	0=gas/fuel0,1=oil/fuel1
x10	R	LMV CURRENT OUTPUT	Unsigned Int 16	x10, see Note 1 below
x11	R	LMV CURRENT SETPOINT	Unsigned Int 16	
x12	R	LMV ACTUAL VALUE	Unsigned Int 16	
x13	R	LMV FLAME SIGNAL	Unsigned Int 16	x10
x14	R	LMV FUEL THROUGHPUT	Unsigned Int 16	
x15	R	LMV CURRENT O ₂	Unsigned Int 16	x10
x16	R	BOILER AUTO	Unsigned Int 16	0=no,1=yes
x17	R	BOILER AVAILABLE	Unsigned Int 16	0=no,1=yes
x18	R	BOILER PUMP RUNNING	Unsigned Int 16	0=no,1=yes
x19	R	BOILER PUMP ALARM	Unsigned Int 16	0=no,1=yes
x21	R	LMV STARTUP COUNTER	Unsigned Int 32	
x23	R	LMV HOUR COUNTER	Unsigned Int 32	
x25	R	LMV CURRENT ERROR CODE	Unsigned Int 16	see LMV... Lockout/Error Codes
x26	R	LMV CURRENT DIAGNOSTIC CODE	Unsigned Int 16	
x27	R	LMV CURRENT ERROR CLASS	Unsigned Int 16	
x28	R	LMV CURRENT ERROR PHASE	Unsigned Int 16	
x29	R	LMV TEMP LIMIT OFF THRESHOLD	Unsigned Int 16	
x30	R	LMV SUPPLY AIR TEMPERATURE	Unsigned Int 16	
x31	R	LMV FLUE GAS TEMPERATURE	Unsigned Int 16	
x32	R	LMV COMBUSTION EFFICIENCY	Unsigned Int 16	x10
x33	R	LMV CURRENT CO ₂	Unsigned Int 16	x10
x34	R	LMV CURRENT EXCESS AIR	Unsigned Int 16	x10
x35	R	LMV INPUT WORD	Unsigned Int 16	word of bits
x35 bit 0	R	LMV CONTROLLER SWITCH	Boolean	
x35 bit 1	R	LMV FAN CONTACTOR	Boolean	
x35 bit 2	R	LMV OIL SELECTED	Boolean	
x35 bit 3	R	LMV GAS SELECTED	Boolean	
x35 bit 5	R	LMV OIL PRESS SW MAX	Boolean	
x35 bit 6	R	LMV OIL PRESS SW MIN	Boolean	

Modbus Mapping – Boiler Data

ADDRESS	ACCESS	DESCRIPTION	FORMAT	NOTES
x35 bit 7	R	LMV VALVE PROVING SW	Boolean	
x35 bit 8	R	LMV SAFETY LOOP	Boolean	
x35 bit 10	R	LMV GAS PRESS SW MIN	Boolean	
x35 bit 11	R	LMV GAS PRESS SW MAX	Boolean	
x35 bit 13	R	LMV AIR PRESSURE SW	Boolean	
x35 bit 14	R	LMV START RELEASE OIL	Boolean	
x35 bit 15	R	LMV HEAVY OIL START	Boolean	
x37	R	LMV OUTPUT WORD	Unsigned Int 16	word of bits
x37 bit 0	R	LMV ALARM	Boolean	
x37 bit 4	R	LMV IGNITION	Boolean	
x37 bit 5	R	LMV START SIGNAL	Boolean	
x37 bit 6	R	LMV FAN OUTPUT	Boolean	
x37 bit 7	R	LMV OIL PUMP	Boolean	
x37 bit 8	R	LMV FUEL VALVE SV OIL	Boolean	
x37 bit 9	R	LMV FUEL VALVE V1 OIL	Boolean	
x37 bit 10	R	LMV FUEL VALVE V2 OIL	Boolean	
x37 bit 11	R	LMV FUEL VALVE V3 OIL	Boolean	
x37 bit 12	R	LMV FUEL VALVE SV GAS	Boolean	
x37 bit 13	R	LMV FUEL VALVE V1 GAS	Boolean	
x37 bit 14	R	LMV FUEL VALVE V2 GAS	Boolean	
x37 bit 15	R	LMV FUEL VALVE PV GAS	Boolean	
x39	R	LMV LOAD CONTROL MODE	Unsigned Int 16	see Note 2 below
x41	R	LMV MODBUS LOCAL/REMOTE	Unsigned Int 16	
x43	R	LMV MODBUS OPERATING MODE	Unsigned Int 16	
x44	R	LMV MODBUS SETPOINT W3	Unsigned Int 16	
x45	R	LMV MODBUS OUTPUT	Unsigned Int 16	
x47	R	LMV SETPOINT W1	Unsigned Int 16	
x48	R	LMV SETPOINT W2	Unsigned Int 16	
x50	R	RWF LC E1 U16	Unsigned Int 16	x10
x51	R	RWF LC E2 U16	Unsigned Int 16	x10
x52	R	RWF LC E3 U16	Unsigned Int 16	x10
x53	R	RWF LC WR CURRENT SP U16	Unsigned Int 16	x10
x54	R	RWF LC SP1 U16	Unsigned Int 16	x10
x55	R	RWF LC INPUT WORD	Unsigned Int 16	
x55 bit 12	R	RWF LC INPUT 1 FAULT	Boolean	
x55 bit 13	R	RWF LC INPUT 2 FAULT	Boolean	
x55 bit 14	R	RWF LC INPUT 3 FAULT	Boolean	
x56	R	RWF LC OUTPUT WORD	Unsigned Int 16	
x56 bit 0	R	RWF LC STAGE MODE	Boolean	
x56 bit 1	R	RWF LC MANUAL OPERATION	Boolean	
x56 bit 2	R	RWF LC BINARY INPUT 1	Boolean	
x56 bit 3	R	RWF LC BINARY INPUT 2	Boolean	
x56 bit 4	R	RWF LC STAT ACTIVE	Boolean	
x56 bit 5	R	RWF LC UP ACTIVE	Boolean	
x56 bit 6	R	RWF LC DOWN ACTIVE	Boolean	
x56 bit 7	R	RWF LC K6 ACTIVE	Boolean	
x58	R	LMV TOTAL VOLUME GAS/FUELO	Unsigned Int 32	
x60	R	LMV TOTAL VOLUME OIL/FUEL1	Unsigned Int 32	
x62	R	LMV EXTRA TEMPERATURE SENSOR	Unsigned Int 16	

Modbus Mapping – Boiler Data

ADDRESS	ACCESS	DESCRIPTION	FORMAT	NOTES
x63	R	FEEDWATER E1 U16	Signed Int 16	x10
x64	R	FEEDWATER E2 U16	Unsigned Int 16	x10
x65	R	FEEDWATER WR CURRENT SP U16	Signed Int 16	x10
x66	R	FEEDWATER SP1 U16	Signed Int 16	x10
x67	R	EA DRAFT SENSOR	Signed Int 16	x100
x68	R	EA DRAFT FEEDBACK	Unsigned Int 16	x10
x70	R	USER VALUE 1	Signed Int 16	see Note 3 below
x71	R	USER VALUE 2	Signed Int 16	see Note 3 below
x72	R	USER VALUE 3	Signed Int 16	see Note 3 below
x73	R	USER VALUE 4	Signed Int 16	see Note 3 below
x74	R	USER VALUE 5	Signed Int 16	see Note 3 below
x75	R	USER VALUE 6	Signed Int 16	see Note 3 below
x76	R	USER VALUE 7	Signed Int 16	see Note 3 below
x77	R	USER VALUE 8	Signed Int 16	see Note 3 below
x78	R	USER VALUE 9	Signed Int 16	see Note 3 below
x79	R	USER VALUE 10	Signed Int 16	see Note 3 below
x80	R	USER VALUE 11	Signed Int 16	see Note 3 below
x81	R	USER VALUE 12	Signed Int 16	see Note 3 below
x82	R	USER VALUE 13	Signed Int 16	see Note 3 below
x83	R	USER VALUE 14	Signed Int 16	see Note 3 below
x84	R	USER VALUE 15	Signed Int 16	see Note 3 below
x85	R	USER VALUE 16	Signed Int 16	see Note 3 below
x86	R	EA STATUS WORD	Unsigned Int 16	
x86 bit 0	R	EA INPUT 1	Boolean	
x86 bit 1	R	EA INPUT 2	Boolean	
x86 bit 2	R	EA INPUT 3	Boolean	
x86 bit 3	R	EA INPUT 4	Boolean	
x86 bit 4	R	EA INPUT 5	Boolean	
x86 bit 5	R	EA INPUT 6	Boolean	
x86 bit 6	R	EA INPUT 7	Boolean	
x86 bit 7	R	EA INPUT 8	Boolean	
x86 bit 8	R	EA INPUT 9	Boolean	
x86 bit 9	R	EA INPUT 10	Boolean	
x86 bit 10	R	EA INPUT 11	Boolean	
x86 bit 11	R	EA INPUT 12	Boolean	
x86 bit 12	R	EA INPUT 13	Boolean	
x87	R	EA ALARM WORD	Unsigned Int 16	
x87 bit 0	R	EA ALARM INPUT 1	Boolean	
x87 bit 1	R	EA ALARM INPUT 2	Boolean	
x87 bit 2	R	EA ALARM INPUT 3	Boolean	
x87 bit 3	R	EA ALARM INPUT 4	Boolean	
x87 bit 4	R	EA ALARM INPUT 5	Boolean	
x87 bit 5	R	EA ALARM INPUT 6	Boolean	
x87 bit 6	R	EA ALARM INPUT 7	Boolean	
x87 bit 7	R	EA ALARM INPUT 8	Boolean	
x87 bit 8	R	EA ALARM INPUT 9	Boolean	
x87 bit 9	R	EA ALARM INPUT 10	Boolean	
x87 bit 10	R	EA ALARM INPUT 11	Boolean	
x87 bit 11	R	EA ALARM INPUT 12	Boolean	

Modbus Mapping – Boiler Data

ADDRESS	ACCESS	DESCRIPTION	FORMAT	NOTES
x87 bit 12	R	EA ALARM INPUT 13	Boolean	
x88	R	EA RTD 1	Signed Int 16	x10
x89	R	EA RTD 2	Signed Int 16	x10
x90	R	EA RTD 3	Signed Int 16	x10
x91	R	EA RTD 4	Signed Int 16	x10
x92	R	EA ANALOG INPUT 1 U16	Signed Int 16	
x93	R	EA ANALOG INPUT 2 U16	Signed Int 16	
x94	R	EA ANALOG INPUT 3 U16	Signed Int 16	
x95	R	EA ANALOG INPUT 4 U16	Signed Int 16	
x96	R	EA ECONOMIZER WATER IN	Unsigned Int 16	x10
x97	R	EA ECONOMIZER WATER OUT	Unsigned Int 16	x10
x98	R	EA ECONOMIZER STACK IN	Unsigned Int 16	x10
x99	R	EA ECONOMIZER STACK OUT	Unsigned Int 16	x10

Note 1 – This value is a percent x10. If the value exceeds 1000, it indicates stages.

- **1001:** 1 stage
- **1002:** 2 stages
- **1003:** 3 stages

Note 2 – LMV5 operating mode.

- **0:** external load control X5-03
- **1:** internal load control
- **2:** internal load control bus
- **3:** internal load control X62
- **4:** external load control X62
- **5:** external load control bus

Note 3 – If the user values are based upon Modbus addresses, the multiplier will be the same as the Modbus address represented. If the user values are based upon scripts, the multiplier will be x10.

Gateway/BMS – Mapping (Deaerator/Surge Tank Data)

Note that 'x' in the address represents the connected Deaerator/Surge Tank Panel (DA/ST) where '10' is DA/ST 1 and '11' is DA/ST 2. For example, 'x00' is 1000 for DA/ST 1 and 1100 for DA/ST 2.

Modbus Mapping – Deaerator/Surge Tank Data

ADDRESS	ACCESS	DESCRIPTION	FORMAT	NOTES
x00	R	PUMP 1 HAND-OFF-AUTO	Unsigned Int 16	2=hand,4=off,8=auto
x01	R	PUMP 2 HAND-OFF-AUTO	Unsigned Int 16	2=hand,4=off,8=auto
x02	R	PUMP 3 HAND-OFF-AUTO	Unsigned Int 16	2=hand,4=off,8=auto
x03	R	PUMP 4 HAND-OFF-AUTO	Unsigned Int 16	2=hand,4=off,8=auto
x04	R	PUMP 5 HAND-OFF-AUTO	Unsigned Int 16	2=hand,4=off,8=auto
x05	R	PUMP 6 HAND-OFF-AUTO	Unsigned Int 16	2=hand,4=off,8=auto
x06	R	DA RWF WATER LEVEL E1	Unsigned Int 16	x10
x07	R	DA RWF WATER LEVEL E2	Unsigned Int 16	x10
x08	R	DA RWF WATER LEVEL WR CURR SP	Unsigned Int 16	x10
x09	R	DA RWF WATER LEVEL Y VALVE POS	Unsigned Int 16	x10
x10	R	SURGE RWF WATER LEVEL E1	Unsigned Int 16	x10
x11	R	SURGE RWF WATER LEVEL E2	Unsigned Int 16	x10
x12	R	SURGE RWF WATER LEVEL WR CURR SP	Unsigned Int 16	x10
x13	R	SURGE RWF WATER LEVEL Y VALVE POS	Unsigned Int 16	x10
x14	R	STEAM RWF WATER LEVEL E1	Unsigned Int 16	x10
x15	R	STEAM RWF WATER LEVEL E2	Unsigned Int 16	x10
x16	R	STEAM RWF WATER LEVEL WR CURR SP	Unsigned Int 16	x10
x17	R	STEAM RWF WATER LEVEL Y VALVE POS	Unsigned Int 16	x10
x18	R	DA BACKUP WTR LVL E1	Unsigned Int 16	x10
x19	R	DA BACKUP WTR LVL E2	Unsigned Int 16	x10
x20	R	DA BACKUP WTR LVL WR CURR SP	Unsigned Int 16	x10
x21	R	DA BACKUP WTR LVL Y VALVE POS	Unsigned Int 16	x10
x22	R	SURGE BACKUP WTR LVL E1	Unsigned Int 16	x10
x23	R	SURGE BACKUP WTR LVL E2	Unsigned Int 16	x10
x24	R	SURGE BACKUP WTR LVL WR CURR SP	Unsigned Int 16	x10
x25	R	SURGE BACKUP WTR LVL Y VALVE POS	Unsigned Int 16	x10
x26	R	PUMP 1 RUN HOURS	Unsigned Int 32	
x28	R	PUMP 2 RUN HOURS	Unsigned Int 32	
x30	R	PUMP 3 RUN HOURS	Unsigned Int 32	
x32	R	PUMP 4 RUN HOURS	Unsigned Int 32	
x34	R	PUMP 5 RUN HOURS	Unsigned Int 32	
x36	R	PUMP 6 RUN HOURS	Unsigned Int 32	
x38	R	RTD 1	Unsigned Int 16	
x39	R	RTD 2	Unsigned Int 16	
x40	R	RTD 3	Unsigned Int 16	
x41	R	RTD 4	Unsigned Int 16	
x42	R	ANALOG INPUT 1	Unsigned Int 16	x10
x43	R	ANALOG INPUT 2	Unsigned Int 16	x10
x44	R	ANALOG INPUT 3	Unsigned Int 16	x10
x45	R	ANALOG INPUT 4	Unsigned Int 16	x10
x46	R	ANALOG INPUT 5	Unsigned Int 16	x10
x47	R	ANALOG INPUT 6	Unsigned Int 16	x10
x48	R	ANALOG INPUT 7	Unsigned Int 16	x10

Modbus Mapping – Deaerator/Surge Tank Data

ADDRESS	ACCESS	DESCRIPTION	FORMAT	NOTES
x49	R	ANALOG INPUT 8	Unsigned Int 16	x10
x50	R	ANALOG OUTPUT 1	Unsigned Int 16	
x51	R	ANALOG OUTPUT 2	Unsigned Int 16	
x52	R	ANALOG OUTPUT 3	Unsigned Int 16	
x53	R	ANALOG OUTPUT 4	Unsigned Int 16	
x54	R	ANALOG OUTPUT 5	Unsigned Int 16	
x55	R	ANALOG OUTPUT 6	Unsigned Int 16	
x56	R	ANALOG OUTPUT 7	Unsigned Int 16	
x57	R	ANALOG OUTPUT 8	Unsigned Int 16	
x58	R	DA SETPOINT W/O VFD	Unsigned Int 16	
x59	R	DA FW PRESSURE W/O VFD	Unsigned Int 16	
x60	R	DA DROP PUMP W/O VFD	Unsigned Int 16	
x61	R	DA ADD PUMP W/O VFD	Unsigned Int 16	
x62	R	DA SETPOINT VFD	Unsigned Int 16	x10
x63	R	DA FW PRESSURE VFD CHANNEL 4	Unsigned Int 16	x10
x64	R	DA FW PRESSURE VFD OFFSET	Unsigned Int 16	x10
x65	R	DA DROP PUMP VFD	Unsigned Int 16	x10
x66	R	DA ADD PUMP VFD	Unsigned Int 16	x10
x67	R	DA START DELAY	Unsigned Int 16	
x68	R	DA STOP DELAY	Unsigned Int 16	
x69	R	DA MINIMUM RUN TIME	Unsigned Int 16	
x70	R	DA OVERLAP TIME	Unsigned Int 16	
x71	R	DA ALTERNATION TIME	Unsigned Int 16	
x72	R	SURGE SETPOINT W/O VFD	Unsigned Int 16	
x73	R	SURGE FW PRESSURE W/O VFD	Unsigned Int 16	
x74	R	SURGE DROP PUMP W/O VFD	Unsigned Int 16	
x75	R	SURGE ADD PUMP W/O VFD	Unsigned Int 16	
x76	R	SURGE SETPOINT VFD	Unsigned Int 16	x10
x77	R	SURGE FW PRESSURE VFD CHANNEL 4	Unsigned Int 16	x10
x78	R	SURGE FW PRESSURE VFD OFFSET	Unsigned Int 16	x10
x79	R	SURGE DROP PUMP VFD	Unsigned Int 16	x10
x80	R	SURGE ADD PUMP VFD	Unsigned Int 16	x10
x81	R	SURGE START DELAY	Unsigned Int 16	
x82	R	SURGE STOP DELAY	Unsigned Int 16	
x83	R	SURGE MINIMUM RUN TIME	Unsigned Int 16	
x84	R	SURGE OVERLAP TIME	Unsigned Int 16	
x85	R	SURGE ALTERNATION TIME	Unsigned Int 16	
x86	R	MANUAL VFD OUTPUT PUMP 1	Unsigned Int 16	
x87	R	MANUAL VFD OUTPUT PUMP 2	Unsigned Int 16	
x88	R	MANUAL VFD OUTPUT PUMP 3	Unsigned Int 16	
x89	R	MANUAL VFD OUTPUT PUMP 4	Unsigned Int 16	
x90	R	MANUAL VFD OUTPUT PUMP 5	Unsigned Int 16	
x91	R	MANUAL VFD OUTPUT PUMP 6	Unsigned Int 16	
x92	R	CONDENSATE LEAD PUMP START DELAY	Unsigned Int 16	
x93	R	CONDENSATE LAG PUMPS START DELAY	Unsigned Int 16	
x94	R	CONDENSATE TIMED LEAD PUMP START	Unsigned Int 16	
x95	R	CONDENSATE TIMED LAG PUMP START	Unsigned Int 16	
x96	R	STATUS WORD 1	Unsigned Int 16	
x96 bit 0	R	LEAD/LAG MODE	Boolean	0=disabled,1=enabled

Modbus Mapping – Deaerator/Surge Tank Data

ADDRESS	ACCESS	DESCRIPTION	FORMAT	NOTES
x96 bit 1	R	DA HIGH WATER	Boolean	0=warning,1=normal
x96 bit 2	R	DA LOW WATER	Boolean	0=warning,1=normal
x96 bit 3	R	DA LOW LOW WATER	Boolean	0=alarm,1=normal
x96 bit 4	R	SURGE HIGH WATER	Boolean	0=warning,1=normal
x96 bit 5	R	SURGE LOW WATER	Boolean	0=warning,1=normal
x96 bit 6	R	SURGE LOW LOW WATER	Boolean	0=alarm,1=normal
x96 bit 7	R	CONDENSATE LAG START	Boolean	0=off,1=on
x96 bit 8	R	CONDENSATE LEAD START	Boolean	0=off,1=on
x96 bit 9	R	CONDENSATE STOP LEAD/LAG	Boolean	0=off,1=on
x96 bit 10	R	PUMP 1 RUNNING	Boolean	0=off,1=on
x96 bit 11	R	PUMP 2 RUNNING	Boolean	0=off,1=on
x96 bit 12	R	PUMP 3 RUNNING	Boolean	0=off,1=on
x96 bit 13	R	PUMP 4 RUNNING	Boolean	0=off,1=on
x96 bit 14	R	PUMP 5 RUNNING	Boolean	0=off,1=on
x96 bit 15	R	PUMP 6 RUNNING	Boolean	0=off,1=on
x97	R	STATUS WORD 2	Unsigned Int 16	
x97 bit 0	R	PUMP 1 FAIL	Boolean	0=normal,1=fail
x97 bit 1	R	PUMP 2 FAIL	Boolean	0=normal,1=fail
x97 bit 2	R	PUMP 3 FAIL	Boolean	0=normal,1=fail
x97 bit 3	R	PUMP 4 FAIL	Boolean	0=normal,1=fail
x97 bit 4	R	PUMP 5 FAIL	Boolean	0=normal,1=fail
x97 bit 5	R	PUMP 6 FAIL	Boolean	0=normal,1=fail
x97 bit 6	R	CONDENSATE PUMP LEAD ENABLE	Boolean	0=off,1=on
x97 bit 7	R	CONDENSATE PUMP LAG ENABLE	Boolean	0=off,1=on

LMV Phases

NUMBER	DESCRIPTION
0	LOCKOUT PHASE
1	SAFETY PHASE
2	SAFETY PHASE
10	HOME RUN POSITION
12	STANDBY STATIONARY
20	SAFETY RELAY ON
21	RELEASE OF STARTUP
22	FAN MOTOR ON
24	DRIVE TO PURGE
30	PREPURGE
32	PREPURGE FGR
34	PREPURGE
35	VSD DRIVE TO IGNITION
36	DRIVE TO IGNITION
38	PREIGNITION SPARK ON
39	GAS VALVE TEST MINIMUM PRESSURE
40	PILOT VALVE OPEN
42	SPARK OFF
44	FLAME STABILIZATION
50	FUEL VALVE OPEN SAFETY TIME
52	FLAME STABILIZATION
54	DRIVE TO LOW FIRE
60	NORMAL OPERATION
62	DRIVE TO LOW FIRE POST
64	DRIVE TO IGNITION
65	FLAME STABILIZATION
66	IGNITION/PILOT ON
67	MAIN VALVE OFF
68	PILOT WAITING TIME
69	PILOT WAITING - STARTUP
70	FUEL VALVE CLOSED AFTER BURN TIME
72	DRIVE TO POSTPURGE
74	MANDATORY POSTPURGE
76	MANDATORY POSTPURGE
78	OPTIONAL POSTPURGE
79	DIRECT START (APS CHECK)
80	GV TEST EVACUATION OF TEST SPACE
81	GV TEST ATMOSPHERIC PRESSURE TEST
82	GV TEST FILL TEST SPACE
83	GV TEST PRESSURE TEST
90	GAS SHORTAGE WAITING TIME
97	NO CONFIGURATION
98	WAITING TO ESTABLISH COMMUNICATION
99	COMMUNICATION FAULT

LMV5 Lockout/Error Codes

LMV5 LOCKOUT/ERROR CODES

CODE DECIMAL	CODE HEX	DESCRIPTION
0	0	NO ERROR
1	1	ROM ERROR
2	2	RAM ERROR
3	3	INTERNAL COMMUNICATION ERROR
4	4	UNSUCCESSFUL SYNC OF 2uCs
5	5	FAULT DURING FLAME AMP TEST
6	6	FAULT INTERNAL HARDWARE TEST
16	10	DIGITAL OUTPUT FAULT
17	11	SHORT CIRCUIT CONTACT FEEDBACK
21	15	ACTUATOR FAULT/VSD SPEED NOT REACHED
22	16	FAULT IN RATIO CONTROL SYSTEM
23	17	LMV5 INTERNAL COM ERROR
24	18	CORRUPTION IN COMBUSTION CURVE DATA
25	19	ACTUATOR POT ERROR
26	1A	ACTUATOR CURVE TOO STEEP
27	1B	ACT CURVE PROGRAMMING ACTIVE PHASE 62
28	1C	ACTUATOR IGNITION POSITION NOT SET
29	1D	RUNNING TIME FAULT ACTUATORS/VSD
30	1E	ACTUATOR/VSD NOT REACHED POSITION
31	1F	VSD MODULE CONNECTION ERROR
33	21	SAFETY LOOP OPEN
34	22	TEMP LIMITER OFF (CHECK SENSOR)
35	23	EXTRANEIOUS LIGHT DURING STARTUP
36	24	EXTRANEIOUS LIGHT DURING SHUTDOWN
37	25	NO FLAME AT END OF SAFETY TIME
38	26	LOSS OF FLAME PHASE 60-62
39	27	AIR PROVE SW ON SHOULD BE OFF
40	28	AIR PROVE SW OFF SHOULD BE ON
41	29	FAN CONTACT SIGNAL ON SHOULD BE OFF
42	2A	FAN CONTACT SIGNAL OFF SHOULD BE ON
43	2B	FGR PRESSURE SW ON SHOULD BE OFF
44	2C	FGR PRESSURE SW OFF SHOULD BE ON
45	2D	CPI (POC) ON SHOULD BE OFF
46	2E	CPI (POC) OFF SHOULD BE ON
47	2F	LOW GAS PRESSURE SWITCH OPEN
48	30	HIGH GAS PRESSURE SWITCH OPEN
49	31	VALVE PROVE – GAS SIDE LEAK
50	32	VALVE PROVE – BURNER SIDE LEAK
51	33	OIL PRESSURE WHEN OIL PUMP OFF
52	34	LOW OIL PRESSURE WHEN PUMP RUNNING
53	35	HIGH OIL PRESSURE SWITCH OPEN
54	36	NO START RELEASE FOR OIL
55	37	NO HEAVY OIL DIRECT START
56	38	SHORTAGE OF GAS PROGRAM IN PROGRESS
57	39	PARAMETER OF MAX SAFETY TIME FAULTY
58	3A	NO BURNER ID DEFINED
59	3B	NO SERVICE PASSWORD DEFINED
64	40	WRONG CONTACT POSITION OF SAFETY TIME

LMV5 LOCKOUT/ERROR CODES

CODE DECIMAL	CODE HEX	DESCRIPTION
65	41	WRONG CONTACT POSITION OF IGNITION
66	42	WRONG CONTACT POSITION OF FUEL RELAY
67	43	PLAUSIBILITY CHECK FAULT
68	44	FAULT AT DEACTIVATED INPUTS
69	45	SHUTDOWN VIA SAFETY LIMIT TEST
70	46	PROGRAM STOP ACTIVATED
71	47	START RELEASE GAS IS OFF
72	48	TWO FLAME SIGNALS WITH ONE PARMETERIZED
80	50	FAULT DURING KEY VALUE CHECK
81	51	TIME BLOCK OVERFLOW
82	52	STACK ERROR
83	53	FAULTY RESET STATE OCCURRED
87	57	INVALID PARAMETERIZATION
88	58	INTERNAL COMMUNICATION (uC1<>uC2)
89	59	EEPROM PAGE IS ON ABORT
90	5A	CRC ERROR OF PARAMETER RANGE
91	5B	PAGE ON ABORT
92	5C	PAGE ON WR_RESTO (BACKUP RESTORE MADE)
93	5D	PAGE OPEN TOO LONG
94	5E	PAGE HAS UNDEFINED STATUS
95	5F	LAST BACKUP RESTORE INVALID (INTERRUPTED)
96	60	FAULT COPYING A PARAMETER PAGE
97	61	FAULT WITH EEPROM INITIALIZATION
112	70	FAULT DURING RESTORING LOCKOUT INFO
113	71	MANUAL LOCKOUT VIA CONTACT
114	72	PLAUSIBILITY FAULT WITH FAULT ENTRY
128	80	WRONG STATE OF AUX3 ACTUATOR
129	81	WRONG STATE OF AIR ACTUATOR
130	82	WRONG STATE OF GAS ACTUATOR
131	83	WRONG STATE OF OIL ACTUATOR
132	84	WRONG STATE OF AUX1 ACTUATOR
133	85	WRONG STATE OF AUX2 ACTUATOR
134	86	WRONG STATE OF INTERNAL LOAD CONTROLLER
135	87	WRONG STATE OF AZL
136	88	PLAUSIBILITY FAULT (NMT)
144	90	ROM-CRC ERROR ON AUX3 FEEDBACK
145	91	ROM-CRC ERROR ON AIR FEEDBACK
146	92	ROM-CRC ERROR ON GAS FEEDBACK
147	93	ROM-CRC ERROR ON OIL FEEDBACK
148	94	ROM-CRC ERROR ON AUX1 FEEDBACK
149	95	ROM-CRC ERROR ON AUX2 FEEDBACK
150	96	ROM-CRC ERROR ON LC FEEDBACK
151	97	ROM-CRC ERROR ON AZL FEEDBACK
152	98	CANBUS DEVICE WITH SAME ADDRESS CONFLICT
153	99	CANBUS IS OFF
154	9A	CANBUS WARNING LEVEL
155	9B	CANBUS QUEUE OVERRUN
160	A0	AUX3 ACTUATOR DETECTED A FAULT
161	A1	AIR ACTUATOR DETECTED A FAULT

LMV5 LOCKOUT/ERROR CODES

CODE DECIMAL	CODE HEX	DESCRIPTION
162	A2	GAS ACTUATOR DETECTED A FAULT
163	A3	OIL ACTUATOR DETECTED A FAULT
164	A4	AUX1 ACTUATOR DETECTED A FAULT
165	A5	AUX2 ACTUATOR DETECTED A FAULT
166	A6	LOAD CONTROL DETECTED A FAULT
167	A7	AZL DETECTED A FAULT
169	A9	VSD MODULE DETECTED A FAULT
171	AB	O ₂ MODULE DETECTED A FAULT
176	B0	FAULT DURING TEST OF PORT OUTPUTS
177	B1	FAULT DURING SHORT CIRCUIT TEST
181	B5	O ₂ MONITOR FAULT
186	BA	O ₂ SENSOR TEST FAILED
187	BB	O ₂ TRIM CONTROL REMOVED
190	BE	INVALID PARAMETERIZATION O ₂ CONTROL
191	BF	O ₂ CONTROL AUTO DEACTIVATION
197	C5	AZL HAS DETECTED OLD UNIT VERSIONS
209	D1	WRONG STATE OF VSD MODULE
211	D3	WRONG STATE OF O ₂ MODULE
225	E1	ROM-CRC ERROR ON VSD MODULE FEEDBACK
227	E3	ROM-CRC ERROR ON O ₂ MODULE FEEDBACK
240	F0	PLAUSIBILITY FAULT (INTERPOLATION)
241	F1	FAULT CALCULATING PRECONTROL
242	F2	FAULTY TEMP VALUES FROM O ₂ MODULE
243	F3	O ₂ TRIM CONTROL FAULT
244	F4	O ₂ MODULE FAULT (FGR)
245	F5	CANBUS FEEDBACK FAULT X60 TEMP INPUT
246	F6	FGR FAULT

LMV3 Error Codes

LMV3 Error Codes	
CODE	DESCRIPTION
2	NO FLAME AT END OF SAFETY TIME
3	AIR PRESSURE FAILURE
4	EXTRANEIOUS LIGHT
7	LOSS OF FLAME
12	VALVE PROVING
14	PROOF OF CLOSURE
18	AIR PRESSURE SWITCH SPEED DEPENDENT
19	COMBUSTION PRESSURE POC
20	PRESSURE SWITCH – MINIMUM
21	PRESSURE SWITCH – MAXIMUM
22	SAFETY LOOP / BURNER FLANGE
23	LOW GAS / HEAVY OIL DIRECT START
50	INTERNAL ERROR
51	INTERNAL ERROR
55	INTERNAL ERROR
56	INTERNAL ERROR
57	INTERNAL ERROR
58	INTERNAL ERROR
60	INTERNAL ERROR – NO VALID HEAT SOURCE
61	FUEL CHANGEOVER
62	INVALID FUEL SIGNALS OR INFORMATION
65	INTERNAL ERROR
66	INTERNAL ERROR
67	INTERNAL ERROR
70	INTERNAL ERROR – FUEL/AIR RATIO CONTROL
71	SPECIAL POSITION UNDEFINED
72	INTERNAL ERROR – FUEL/AIR RATIO CONTROL
73	INTERNAL ERROR – FUEL/AIR RATIO CONTROL
75	INTERNAL ERROR – FUEL/AIR RATIO CONTROL
76	INTERNAL ERROR – FUEL/AIR RATIO CONTROL
80	CONTROL RANGE LIMIT OF VSD
81	VSD ELECTROMAGNETIC INTERFERENCE
82	ERROR DURING VSD SPEED STANDARDIZATION
83	SPEED ERROR VSD
84	CURVE SLOPE ACTUATORS
85	ACTUATOR REFERENCING ERROR
86	ERROR FUEL ACTUATOR
87	ERROR AIR ACTUATOR
90	INTERNAL ERROR – BASIC UNIT
91	INTERNAL ERROR – BASIC UNIT
93	ERROR FLAME SIGNAL ACQUISITION
95	ERROR RELAY SUPERVISION
96	ERROR RELAY SUPERVISION
97	ERROR RELAY SUPERVISION
98	ERROR RELAY SUPERVISION
99	INTERNAL ERROR – RELAY CONTROL
100	INTERNAL ERROR – RELAY CONTROL
105	INTERNAL ERROR – CONTACT SAMPLING

LMV3 Error Codes

CODE	DESCRIPTION
106	INTERNAL ERROR – CONTACT REQUEST
107	INTERNAL ERROR – CONTACT REQUEST
108	INTERNAL ERROR – CONTACT REQUEST
110	INTERNAL ERROR – VOLTAGE MONITOR TEST
111	POWER FAILURE
112	MAINS VOLTAGE RECOVERY
113	INTERNAL ERROR – MAINS VOLTAGE
115	INTERNAL ERROR – SYSTEM COUNTER
116	DESIGN THRESHOLD EXCEEDED
117	LIFETIME EXCEEDED – OPERATION NOT ALLOWED
120	FUEL METERING INTERFERENCE
121	INTERNAL ERROR – EEPROM ACCESS
122	INTERNAL ERROR – EEPROM ACCESS
123	INTERNAL ERROR – EEPROM ACCESS
124	INTERNAL ERROR – EEPROM ACCESS
125	INTERNAL ERROR – EEPROM READ ACCESS
126	INTERNAL ERROR – EEPROM WRITE ACCESS
127	INTERNAL ERROR – EEPROM ACCESS
128	INTERNAL ERROR – EEPROM ACCESS
129	INTERNAL ERROR – EEPROM ACCESS
130	INTERNAL ERROR – EEPROM ACCESS
131	INTERNAL ERROR – EEPROM ACCESS
132	INTERNAL ERROR – EEPROM REG INITIALIZATION
133	INTERNAL ERROR – EEPROM REQUEST SYNC
134	INTERNAL ERROR – EEPROM REQUEST SYNC
135	INTERNAL ERROR – EEPROM REQUEST SYNC
136	RESTORE STARTED
137	INTERNAL ERROR – BACKUP/RESTORE
146	TIMEOUT – BAS MODBUS
150	TUV TEST
154	TRIM FUNCTION – INVALID ANALOG
155	TRIM FUNCTION – INVALID CURVE
156	TRIM FUNCTION – TIMEOUT
157	TRIM FUNCTION – TEST FAIL
165	INTERNAL ERROR
166	INTERNAL ERROR – WATCHDOG TEST
167	MANUAL LOCKING
168	INTERNAL ERROR – MANAGEMENT
169	INTERNAL ERROR – MANAGEMENT
170	INTERNAL ERROR – MANAGEMENT
171	INTERNAL ERROR – MANAGEMENT
200	NO ERROR
201	PREVENTION OF STARTUP
202	INTERNAL ERROR – OPERATING MODE SELECT
203	INTERNAL ERROR
204	PROGRAM STOP
205	INTERNAL ERROR
206	COMBINATION OF UNITS NOT ALLOWED
207	AZL VERSION COMPATIBILITY ERROR

LMV3 Error Codes

CODE	DESCRIPTION
208	INTERNAL ERROR
209	INTERNAL ERROR
210	SELECTED MODE NOT RELEASED FOR BASIC UNIT
240	INTERNAL ERROR
242	INVALID PARAMETERIZATION
245	INTERNAL ERROR
250	INTERNAL ERROR

Sample Monitored Value Applications

Domestic Hot Water Priority

Domestic hot water (DHW) priority can be implemented using the W2 setpoint.

Procedure

Changing over to the W2 setpoint is accomplished via the 'W2 Setpoint' digital input. When activated, the W2 setpoint has priority over all other setpoint sources. The W2 setpoint is changed from the SETPOINTS screen on the Lead/Lag Master.

Using Digital Input from Thermostat

The easiest way to implement DHW priority is to connect a thermostat control directly to the 'W2 Setpoint' digital input. This is a low-voltage 24VDC connection.

Using Analog or RTD Input

If one of the analog or RTD inputs is configured to monitor the temperature of the DHW tank, this can be used as a monitored digital output in order to activate the 'W2 Setpoint' digital input.

First, configure the analog or RTD input.

ANALOG INPUT 1

NAME:	DHW Tank		RESET TAG
UNIT:	F	TYPE:	4-20mA
		FILTER:	0
MIN:	50	MAX:	250
		TOTALS:	None
LOW:	0	HIGH:	0
		ALARM:	None

Exit

Sample Monitored Value Applications (continued)

Next, configure the monitored digital output to activate when the DHW tank temperature is below the desired DHW setpoint. This is shown under 'CONDITION 1'. The DHW tank temperature is connected to analog input 1, so that is the value to monitor. From the Modbus mapping, it is known that this value is represented x10, so it is necessary to apply a divider of 10. If the value is copied using the register lookup function, this will be done automatically. Since the action should be true when the monitored value is below the setpoint, choose < as the function.

'CONDITION 2' will not be used, so set the slider switch to **OFF**. Apply an off delay to provide a minimum run time to prevent short cycling of the input.

The screenshot displays the configuration interface for 'MONITOR OUTPUT 3 (DIGITAL)'. It is divided into three main sections:

- CONDITION 1:**
 - MODBUS ADDRESS TO MONITOR: 13 / 10
 - LLM ANALOG INPUT 1 U16
 - WHEN: < SETPOINT: 150.0
- CONDITION 2:**
 - OFF ON
 - MODBUS ADDRESS TO MONITOR: 99 / 1
 - UNUSED OR PARTIAL REGISTER
 - WHEN: = SETPOINT: 999.0
- OUTPUT IS ACTIVE WHEN:**
 - CONDITION 1 OR CONDITION 2
 - APPLY DELAY OFF OF 300s
 - OPTIONS: LATCH = NO, ALARM = NO, CURRENT = TRUE
 - Exit button at the bottom.

Sample Monitored Value Applications (continued)

Wiring

Wire the monitored digital output to the 'W2 Setpoint' digital input to complete the process. Note that the terminals MVx-1 and MVx-2 refer to the specific monitored output used (for example, monitored output 3 would use terminals MV3-1 and MV3-2).

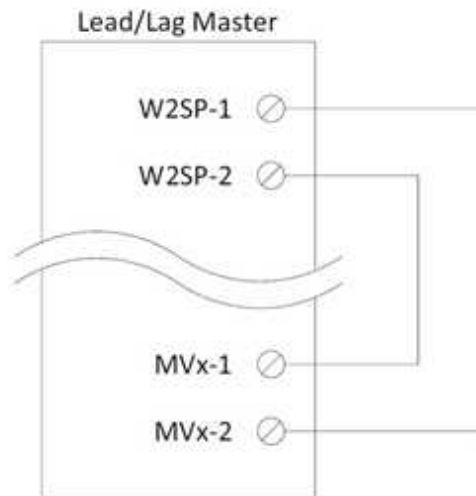

Sample Monitored Value Applications (continued)

Time-Based Actions

Monitored digital outputs can be configured to provide a time-based action such as a valve opening.

Procedure

An example of a time-based action could be a blow-down valve that opens once a day for 30 seconds. The time selected for this action will be 23:59.

Configure 'CONDITION 1' of the monitored digital output to activate when the hour is equal to '23'. The time and date data is available from the LMV5 via Modbus. From the Modbus mapping, it is known that this value is represented without a divider, so a divider of 1 is entered. If the value is copied using the register lookup function, this will be done automatically. Since the action should be true when the monitored value equals the setpoint, choose = as the function.

Activate 'CONDITION 2' by setting the slider switch to **ON**, then configure the monitored digital output to activate when the minute is equal to '59', following the above guidelines.

Choose **AND** as the logic applied between the conditions. Apply a 20 second on delay to keep the output inactive for the first 20 seconds of the condition being true. This is done since the action is only desired for 30 seconds instead of the full minute. Allow some extra time for communication of the data.

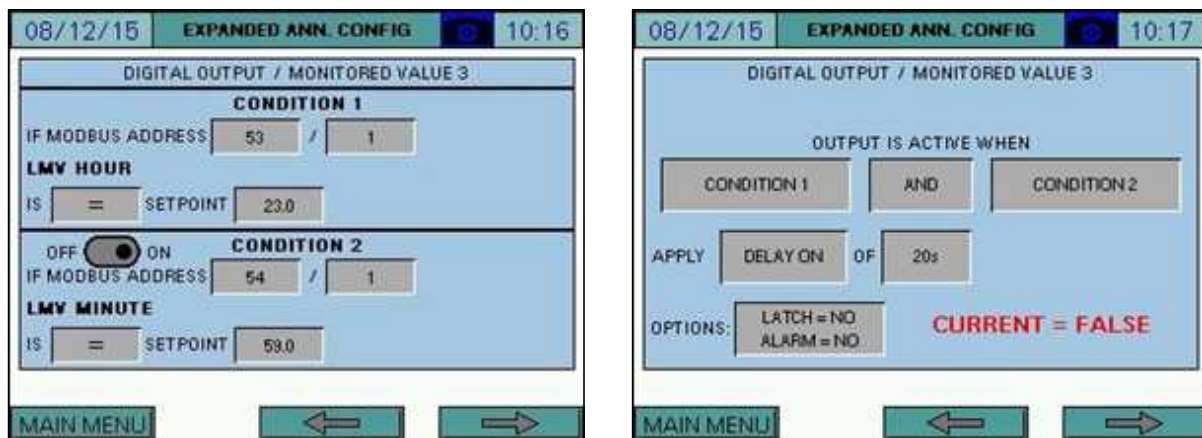

If desired, the action can be latched and/or create an alarm when true. Latching would require a manual reset via the ALARMS screen to clear the condition.

Sample Monitored Value Applications (continued)

Wiring

Wire the monitored digital output into the external action to complete the process. Note that the terminals MVx-1 and MVx-2 refer to the specific monitored output used (for example, monitored output 3 would use terminals MV3-1 and MV3-2).

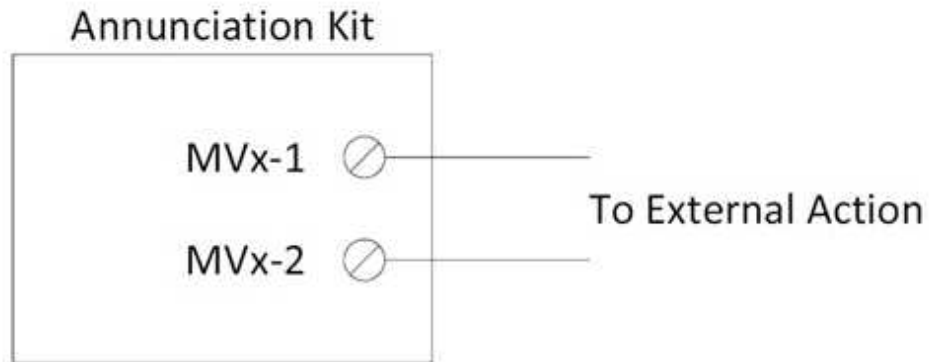

Creating User Value Scripts

User value scripts will only work on revision 17M1 and newer. Up to 16 user scripts can be added for additional value calculations.

Purpose

User scripts allow additional data to be monitored, processed or displayed. This is useful when non-standard annunciation is required on the touchscreen or via BMS. The resulting data can also be used with monitored values to expand upon the logic that triggers them.

Format

User scripts are simple text (.txt) files. To be recognized, the file must be named "displayX.txt", where the X represents the script number from 0 to 15 (such as display0.txt). These files must be placed in the "userval" folder of the SD card. They can also be loaded from a USB drive (also place in the "userval" folder) using the "Manage" popup (see *User Value Scripts* for additional detail).

Variables

There are 16 retentive and 16 non-retentive variables available to use for writing scripts. The retentive variables are m0-m15 and the non-retentive variables are v0-v15.

Comments

"#" is used to indicate that the line contains a comment. Any content after the "#" is ignored as long as it is on the same line.

Breaks

Each command must be on a new line. There are no end of line characters such as ";".

Length

The maximum number of lines per script is 100.

Creating User Value Scripts (continued)

Syntax Summary

Keyword	Description	Example
name=	The name for the value.	name=Temperature
suffix=	The suffix (units) for the value.	suffix=PSI
state=	Indicates the value is discrete/binary and supplies the true/false text.	state=On,Off
show=	Indicates whether the value should be displayed on a boiler overview screen.	show=int:1,0,v0:2
math=	Math function to be applied to data.	math=index:100,int:2,add,v0
logic=	Logic function to be applied to data.	logic=index:112,int:200,gt,v0
ret=	Returns the specified variable to the "User Values" screen.	ret=v0:2
v0= v1= ... v15=	Assigns a value to the indicated non-retentive variable.	v0=12.5
m0= m1= ... m15=	Assigns a value to the indicated retentive variable.	m0=12.5

Syntax Detail: name=

Any text after "name=" is acceptable (including spaces). The total length of the user value display is 60 characters including the value and suffix.

Syntax Detail: suffix=

Any text after "suffix=" is acceptable (including spaces). The total length of the user value display is 60 characters including the value and name.

Syntax Detail: state=

Any text after "state=" is acceptable (including spaces). The total length of the user value display is 60 characters including the name and suffix. The text must contain the true and false annunciations (in that order) separated by a comma. This keyword should only be included if the output is intended to be discrete/binary.

Creating User Value Scripts (continued)

Syntax Detail: show=

This keyword is used to indicate that a variable should be displayed on one of the boiler overview screens.

Required parameters, separated by a comma:

Visibility

The data will be visible on the overview screen when the value of the visibility data is greater than zero. The format is the type of data followed by the value/address, separated by a colon.

Keyword	Description	Example
int	The value is an integer. Any value greater than zero will force visibility to true.	int:1
index	A Modbus register is used to supply the visibility. The number indicates the Modbus index.	index:112
var	An internal non-retentive variable is used to supply the visibility. Use 0-15 (not v0-v15).	var:0
mem	An internal retentive variable is used to supply the visibility. Use 0-15 (not m0-m15).	mem:0

Position

Indicates which boiler overview screen and position the data should appear on.

0, 1: B-1 overview, line 1 or line 2

2, 3: B-2 overview, line 1 or line 2

4, 5: B-3 overview, line 1 or line 2

6, 7: B-4 overview, line 1 or line 2

8, 9: B-5 overview, line 1 or line 2

10, 11: B-6 overview, line 1 or line 2

12, 13: B-7 overview, line 1 or line 2

14, 15: B-8 overview, line 1 or line 2

Variable

Indicates which variable is to be displayed ("v0:x"... "v15:x" or "m0:x"... "m15:x"). The value after ":" indicates how many decimal places to show. Using "iv0:0"... "iv15:0" or "im0:0"... "im15:0" will show the result as a rounded integer without regard for decimal places. Using "rv0:0"... "rv15:0" or "rm0:0"... "rm15:0" will show the result as a raw floating point number without rounding. Use the value "0" after ":" for iv, im, rv and rm.

Examples:

```
#shows v0 on B-1 overview, line 1 continuously as an integer
```

```
show=int:1,0,iv0:0
```

```
#shows v1 on B-2 overview, line 1 continuously with one decimal
```

```
show=int:1,2,v1:1
```

Creating User Value Scripts (continued)

Syntax Detail: math=

This keyword is used to indicate that math should be performed.

Required parameters, separated by a comma:

Variable X

The data used for the first variable (indicated as "x" in function descriptions).

Variable Y

The data used for the second variable (indicated as "y" in function descriptions).

Variable X and Variable Y assignments:

Keyword	Description	Example
int	The value is an integer.	int:1
float	The value is a float.	float:12.5
index	A Modbus register is used to supply the value. The number indicates the Modbus index.	index:112
var	An internal non-retentive variable is used to supply the value. Use 0-15 (not v0-v15).	var:0
mem	An internal retentive variable is used to supply the value. Use 0-15 (not m0-m15).	mem:0

Functions:

Keyword	Description
add +	Addition of the two variables. output = x + y
sub -	Subtraction of the two variables. output = x - y
mult *	Multiplication of the two variables. output = x * y
div /	Division of the two variables. output = x / y
mod %	Modulo of the two variables (modulo is remainder of division operation). output = x % y
pow ^	Exponent of the two variables, x to the power of y. output = x ^y
root	Root of the two variables, y root of x. output = x ^{1/y}
min	Output is the lower of the two variables.
max	Output is the higher of the two variables.
abs	The absolute value of the x is returned (y is ignored).

Creating User Value Scripts (continued)

Return

Indicates which variable the result is returned to ("v0"..."v15" or "m0"..."m15").

Examples:

```
#calculate 10 * 2 and put the result in v0  
math=int:10,int:2,mult,v0  
#calculate Modbus[112] * 0.8 and put the result in v0  
math=index:112,float:0.8,mult,v0
```

Compound Example (convert Modbus[112] from Fahrenheit to Celsius):

```
#subtracts 32 from Modbus[112] and stores in v0  
math=index:112,int:32,sub,v0  
#divide v0 by 9 and store in v0 again  
math=var:0,int:9,div,v0  
#multiply v0 by 5 and store in v0 again  
math=var:0,int:5,mult,v0
```

Creating User Value Scripts (continued)

Syntax Detail: logic=

This keyword is used to indicate that logic should be performed. Unlike math, with logic either a "1" or a "0" are returned to the indicated variable (except for functions "lsh", "rsh" and "flip").

Required parameters, separated by a comma:

Variable X

The data used for the first variable (indicated as "x" in function descriptions).

Variable Y

The data used for the second variable (indicated as "y" in function descriptions).

Variable X and Variable Y assignments:

Keyword	Description	Example
int	The value is an integer.	int:1
float	The value is a float.	float:12.5
index	A Modbus register is used to supply the value. The number indicates the Modbus index.	index:112
var	An internal non-retentive variable is used to supply the value. Use 0-15 (not v0-v15).	var:0
mem	An internal retentive variable is used to supply the value. Use 0-15 (not m0-m15).	mem:0

Creating User Value Scripts (continued)

Functions:

Keyword	Description
ge >=	True if x is greater than or equal y, else false.
gt >	True if x is greater than y, else false.
le <=	True if x is less than or equal to y, else false.
lt <	True if x is less than y, else false.
ne <> !=	True if x is not equal to y, else false.
eq == =	True if x is equal to y, else false.
or 	True if either x or y are true, else false.
and &&	True if both x and y are true, else false.
bit	Status of bit y of word x.
bor 	Boolean OR (x OR y).
band &	Boolean AND (x AND y).
bxor ^	Boolean XOR (x XOR y).
not !	The opposite of x is returned (y is ignored).
lsh <<	Left shifts bits of word x by y positions.
rsh >>	Right shifts bits of word x by y positions.
flip ~	Inverts bits of x (y is ignored).

Return

Indicates which variable the result is returned to. Specifying "xv0"... "xv15" or "xm0"... "xm15" will set the selected variable to 0. Specifying "sv0=xxx"... "sv15=xxx" or "sm0=xxx"... "sm15=xxx" will set the selected variable to the value xxx.

Creating User Value Scripts (continued)

Examples:

```
#returns Modbus[160] > 2000 and put result in v0  
logic=index:160,int:2000,gt,v0  
#returns Modbus[100] = 60 and put result in v0  
logic=index:100,int:60,eq,v0
```

Syntax Detail: ret=

Indicates which variable is to be returned to the "User Values" screen as well as the corresponding Modbus register ("v0:x"..."v15:x" or "m0:x"..."m15:x"). The value after ":" indicates how many decimal places to show on the "User Values" screen. Using "iv0:0"..."iv15:0" or "im0:0"..."im15:0" will show the result as a rounded integer without regard for decimal places. Using "rv0:0"..."rv15:0" or "rm0:0"..."rm15:0" will show the result as a raw floating point number without rounding. Use the value "0" after ":" for iv, im, rv and rm. Regardless of the display format chosen the Modbus representation will be x10.

Example Scripts

Monitors temperature of B-1 and displays "Temperature: High" when it is above 200 on the "User Values" screen and on the "B-1 Overview" screen.

```
#script 1  
name=Temperature  
state=High,Normal  
logic=index:112,int:200,gt,v0  
ret=iv0:0  
show=int:1,0,iv0:0
```

Averages the temperatures of B-1, B-2 and B-3 for display on the "User Values" screen.

```
#script 2  
name=Average  
suffix=°F  
math=index:112,index:212,add,v0  
math=var:0,index:312,add,v0  
math=var:0,int:3,div,v0  
ret=v0:1
```

LMV5 Configuration for Modbus (Serial Connection)

The LMV5... controller must be properly configured for Modbus operation. Use the **Select <** and **Select >** buttons to navigate up and down the screen and the **Enter** button when the desired option is selected with the cursor. Use **Esc** to go back to the previous menu. When a parameter needs to be changed, the **Select <** and **Select >** buttons allow the value to be changed and **Enter** confirms the change. Press the **Esc** button to return after the change is made.

First, activate the Modbus port on the AZL (no password required):

1. Operation > OptgModeSelect > Type of Gateway = **Modbus**
2. Operation > OptgModeSelect > **GatewayBASon** (older units **GatewayDDCon**)
3. The AZL should now read 'Gateway Mode active'.

Next, set up the required parameters through the AZL (no password required):

1. Params & Display > Access w-out PW > AZL > Modbus >
Address = **<(boiler number x 10) + 1>** (Boiler 1 = 11, Boiler 2 = 21, etc.)
2. Params & Display > Access w-out PW > AZL > Modbus > Baudrate = **19200 bit/s**
3. Params & Display > Access w-out PW > AZL > Modbus > Parity = **no**
4. Params & Display > Access w-out PW > AZL > Modbus > Timeout = **30s**

Last, change the controller mode to allow Modbus operation (no password required):

1. Params & Display > Access w-out PW > LoadController > Configuration >
LC_OptgMode = **IntLC Bus**

The changes take effect immediately (no reboot required).

Log in to the AZL at the Service level (default password 9876) and change the following:

1. Params & Display > Access Serv > LoadController > Configuration >
Ext MaxSetpoint = **100%**
2. Params & Display > Access Serv > BurnerControl > Configuration >
ConfigGeneral > AlarmStartPrev = **activated**
3. Params & Display > Access Serv > BurnerControl > Configuration >
ConfigGeneral > Standby Error = **activated**

If X62.1 and X62.2 are switched with a Local/Remote switch or similar as part of a remote enable package, disconnect the wires from these terminals. Failing to do so may result in the control not accepting a setpoint from the Lead/Lag Master.

LMV3 Configuration for Modbus (Serial Connection)

The LMV3.. controller must have a compatible OCI option installed (OCI412.10 or OCI413.20) in order to communicate with the system via Modbus.

The service (heating engineer) password must be entered for these parameters to be accessed. The default service password is 9876. If the password has been changed, please consult the equipment OEM for the correct password.

To configure the LMV3... controller to communicate using Modbus, use the following procedure:

1. Hold down both the **F** and the **A** buttons until the display reads 'Code', followed by a string of seven underscores.
2. Use the **+** and **-** buttons to enter the password. Press **ENTER** (the button to the right of the display) after each entry, and again once the complete password is entered. If the password is incorrect, 'Error' will be displayed and the process will have to be restarted.
3. If the password is entered successfully, the screen will display 'Para' and then '400: Set' with the '400:' flashing.
4. Use the **-** button to navigate to '100: PArA', then press **ENTER**.
5. Use the **+** and **-** buttons to navigate to a flashing '141:'. If this value does not read **1**, press **ENTER** and then use the **+** and **-** buttons to change it to **1**, then press **ENTER** to confirm the change. This parameter activates Modbus. To return to the parameter navigation, press the **+** and **-** buttons simultaneously (**ESC**). The display should return to flashing '141:'. This procedure will be used to change all parameters.
6. Change '142:' to **120**. This parameter sets the timeout.
7. Change '145:' to **<(boiler number x 10) + 1>** (Boiler 1 = 11, Boiler 2 = 21, etc.). This parameter sets the Modbus address.
8. Change '146:' to **1**. This parameter sets the baud rate to 19200 bit/s.
9. Change '147:' to **0**. This parameter sets the parity to none.
10. When all the parameters are entered, press **ESC** in two successions to back up to the main screen. The changes take effect immediately (no reboot required).

RWF55 Configuration for Modbus (Serial Connection)

The RWF55 must be properly configured for Modbus operation.

Use the up and down arrow buttons to navigate through the menus and the **Enter** button when the desired menu is selected. Use **Esc** to go back to the previous menu. When a parameter needs to be changed, the up and down arrow buttons allow the value to be changed and **Enter** confirms the change. The parameter name will flash on the green display when the parameter entry mode is entered. Press the **Esc** button to return after the change is made.

To configure the RWF55 controller to communicate using Modbus, use the following procedure:

1. Press **Enter** to go into the menu list. The green display should read 'Opr'.
2. ConF > IntF > r485 > bdr = **2** (19200 bit/s baud rate)
3. ConF > IntF > r485 > dt = **30** (timeout)
4. For load controller applications:
ConF > IntF > r485 > ADR = **<(boiler number x 10) + 2>** (Boiler 1 = 12, Boiler 2 = 22, etc.)
5. For feedwater applications:
ConF > IntF > r485 > ADR = **<(boiler number x 10) + 3>** (Boiler 1 = 13, Boiler 2 = 23, etc.)
6. Press **Esc** in four successions or until the parameter menus are completely exited. The changes take effect immediately (no reboot required).

If either the shell or inlet temperature sensor is connected to the RWF55 via analog input 3:

1. ConF > InP > InP3 > dF3 = **0** (analog input filter)

If the RWF55 is used as a standalone load controller the running status of the connected boiler must be connected by wiring dry run status contacts to terminals D1 and DG on the RWF55. The alarm status can also be connected but is optional. The alarm status dry contacts are wired to terminals D2 and DG on the RWF55. If there are no run contacts or alarm contacts the best method is to wire relays to the main fuel valve output and alarm output of the flame safety device.

For connection of the 4-20mA control signal to a 135-ohm input (used on third-party modulating motors) use **SCC part number TS-M4-303R** (resistor kit for signal conversion).

RWF10 Configuration for Modbus (Serial Connection)

The RWF10 must have the Modbus option in order to communicate with the system. This is an option card that is inserted into the controller when required.

To configure the RWF10 controller to communicate using Modbus, use the following procedure:

1. Press the **LEVEL** (left-most) button until the red display reads 'CN-t'.
2. Press the **LEVEL** button again; the red display should read 'PSEL'.
3. If the value of 'PSEL' does not read **Mod**, use the up and down arrow buttons to change the value.
4. Press the **MODE** (loop with arrow on end, second from left) button to move to the next parameter, 'U-No'. Change the value to **<(boiler number x 10) + 2>** (Boiler 1 = 12, Boiler 2 = 22, etc.) with the up and down arrow buttons and then press **MODE**. This parameter sets the Modbus address.
5. Change parameter 'bPS' to **19.2** and then press **MODE**. This parameter sets the baud rate to 19,200 bit/s.
6. Change parameter 'PRtY' to **None** and then press **MODE**. This parameter sets the parity to none.
7. Change parameter 'SdWt' to **20** and then press **MODE**. This parameter sets the timeout.
8. Once 'PSEL' is displayed again, press and hold the **LEVEL** button to save the changes. The unit will reboot with the new parameters and the changes will take effect immediately.

If an analog transmitter is being used for steam pressure or water temperature the unit must be configured to display one decimal point:

1. Press the **LEVEL** (left-most) button until the red display reads 'CN-t'.
2. Press the **MODE** (loop with arrow on end, second from left) button three times to display parameter 'dP'. Change the value to **1**.
3. Press and hold the **LEVEL** button to save the changes. The unit will reboot with the new parameters and the changes will take effect immediately.

Loading Software Updates

Software updates can be field-applied using a USB drive (touchscreens) or an SD card (PLCs).

Preparing Media

If a software update is necessary, the files will be distributed in a ZIP folder. To load the contents to the device, the contents of the ZIP folder must be copied to the root directory of a USB drive or SD card.

TOUCHSCREEN

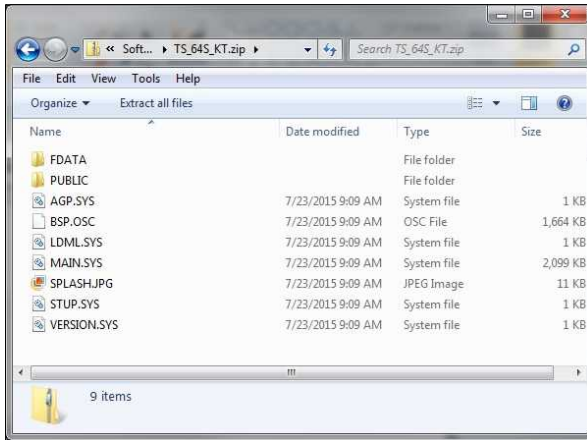

PLC

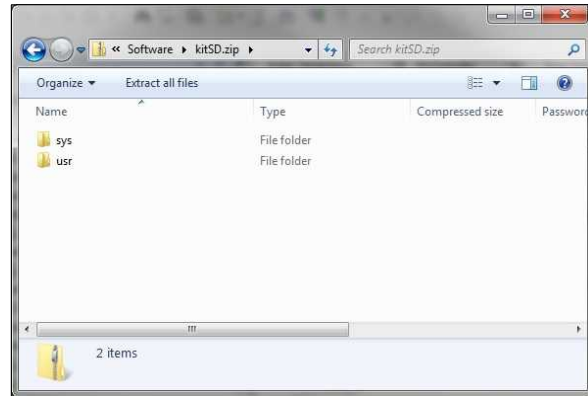

TOUCHSCREEN

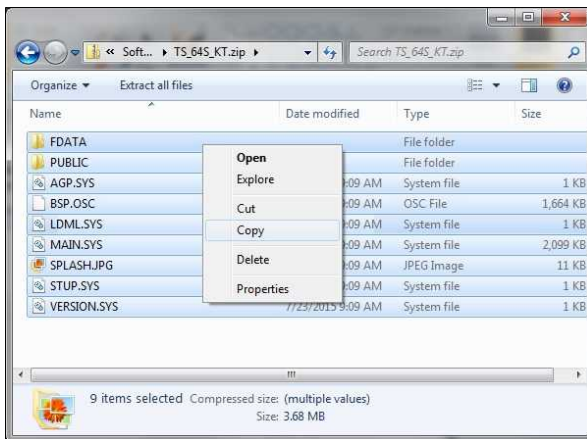

PLC

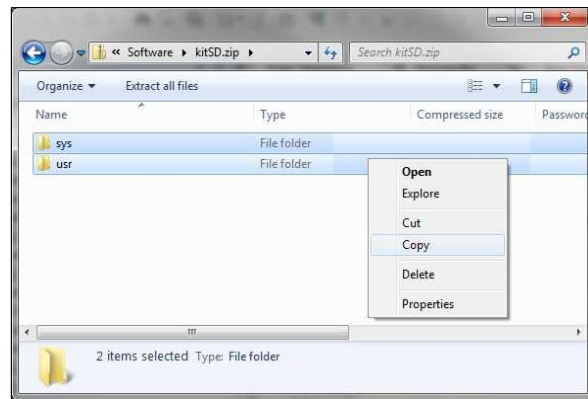

Loading Software Updates (continued)

Ensure that the USB drive or SD card is completely empty, then paste the contents.

TOUCHSCREEN

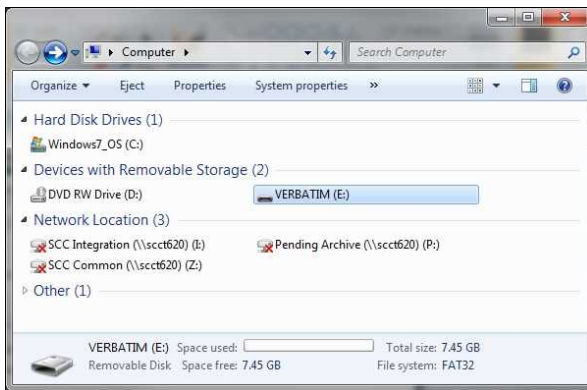

PLC

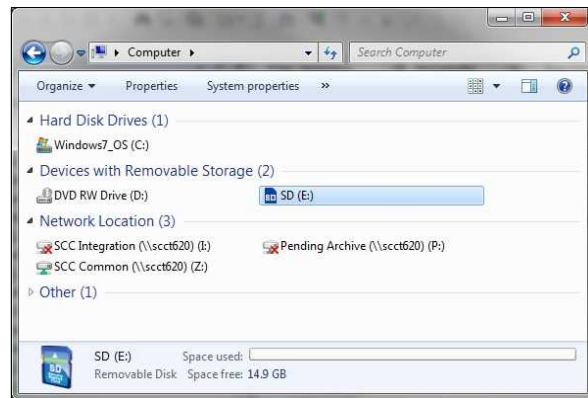

TOUCHSCREEN

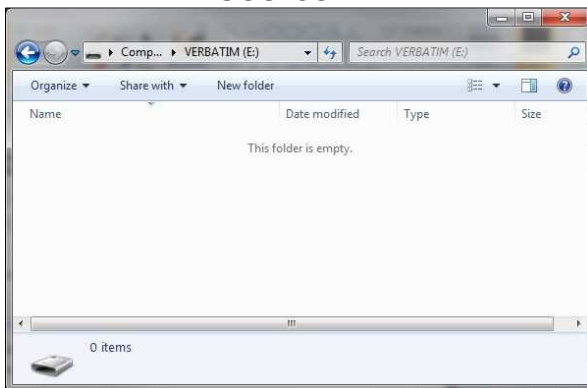

PLC

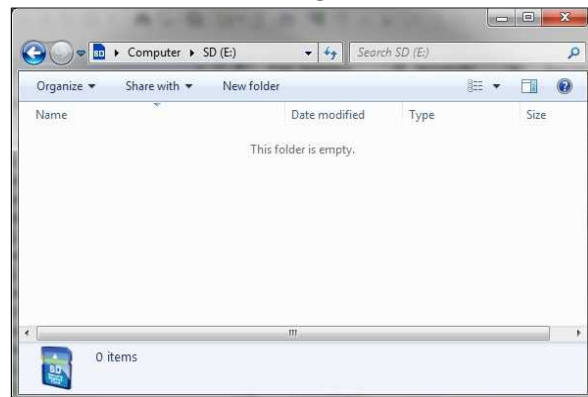

TOUCHSCREEN

PLC

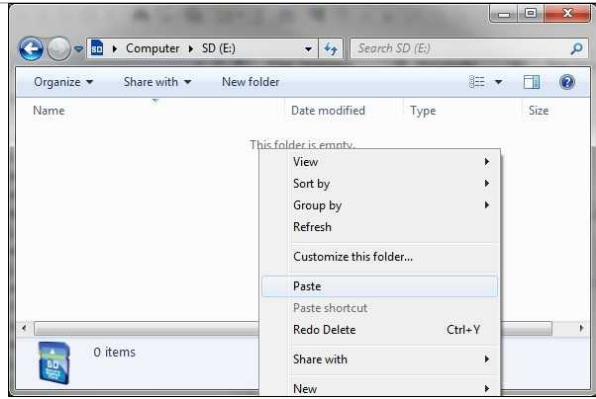
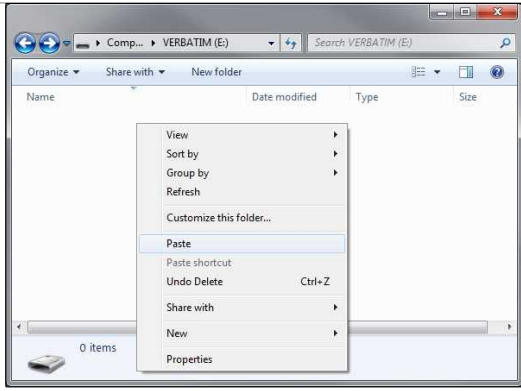

Loading Software Updates (continued)

Check that the contents are as follows before proceeding. This should match the contents of the ZIP folder.

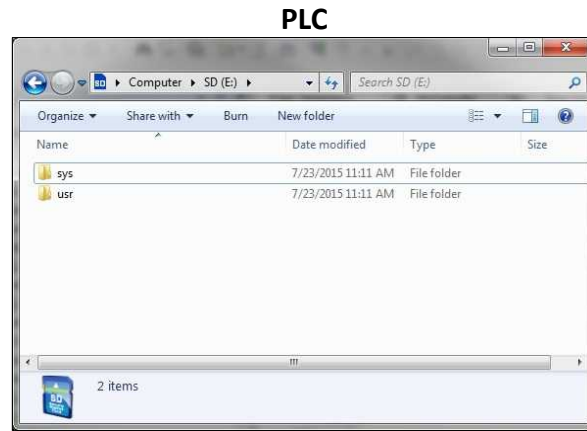
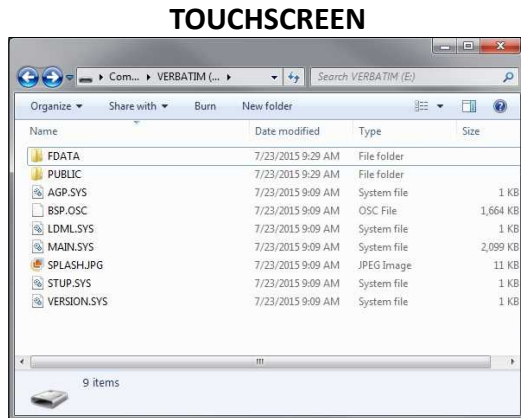

Loading Files to Touchscreen

To copy the files into a touchscreen, insert the USB drive, then press **YES** when asked if you want to proceed with the installation.



Loading Software Updates (continued)

When the installation is complete, remove the USB drive and press **Restart**.



The device will then reboot with the new software and the process is complete. If an activation is necessary, contact SCC Inc. technical support with the activation code displayed and enter the key given to complete the activation process.

Loading Software Updates (continued)

Loading Files to PLC

To copy the files into a PLC, first power the device off. Once it is powered off, insert the SD card. When the device is powered on, the 'SD' LED will flash as the device loads the software. When it is finished loading, the 'SD' LED will be a steady green and the 'ERR' LED will be flashing red. Eject the SD card and the PLC will reboot with the new software (no power cycle required).



The PLC may require activation when the updates are complete. If an activation is necessary, contact SCC Inc. technical support with the activation code displayed and enter the key given to complete the activation process. If the default IP address of the PLC had been changed, it will be necessary to establish a serial link and perform that procedure again.

ACS800 Software

ACS800 software allows remote monitoring, screen control and data logging when connected to any TS series touchscreen. ACS800 software requires a 64-bit version of Windows 7 or newer. Only one instance of ACS800 can be opened.

Once started, ACS800 will begin on the Device Control screen, attempting to connect to the last connected device.

The computer must be connected to the same network and have a compatible IP address to establish a connection with a touchscreen.

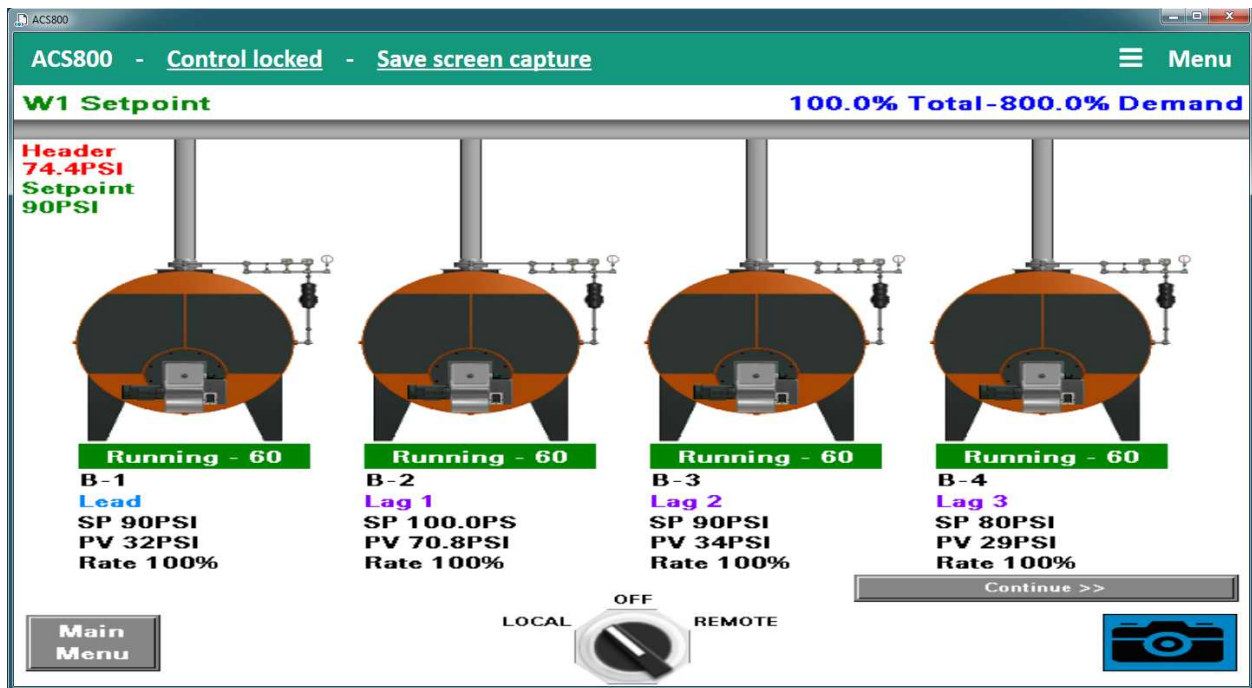

To navigate, expand the Main Menu in the upper right corner of the screen. The menu options are:

- **Device Control** – Remote viewer used to monitor or control the touchscreen.
- **Data Collection** – Allows data trend collection of up to eight channels.
- **System Configuration** – Used to specify the device to connect as well as other diagnostics.
- **Export Data** – Used to export data trends to Microsoft Excel formatted files.
- **Exit Application** – Exits ACS800.

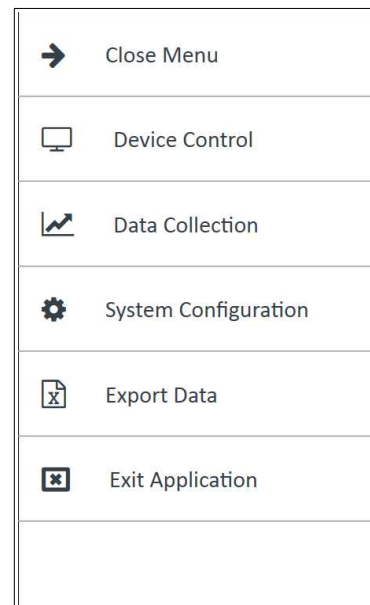

ACS800 Software (continued)

Device Control

This screen allows viewing of the connected touchscreen. The screen can be resized by dragging the lower right hand corner to the desired size.

Remote control of the connected touchscreen is allowed with a password. The default password is "SCC". Click **Control locked** to enter the password and allow remote control.



Once unlocked, the button will change to read **Control unlocked**. Click again to disable remote control.



A screen capture of the current screen can be saved in the native resolution by clicking **Save screen capture**. The file format of the screen capture is png.

ACS800 Software (continued)

Data Collection

This screen allows data trend collection of up to eight channels. All of the available data points for the connected device will be presented in a drop-down menu. Choose the desired data point and click **Add** to add a channel with that point.

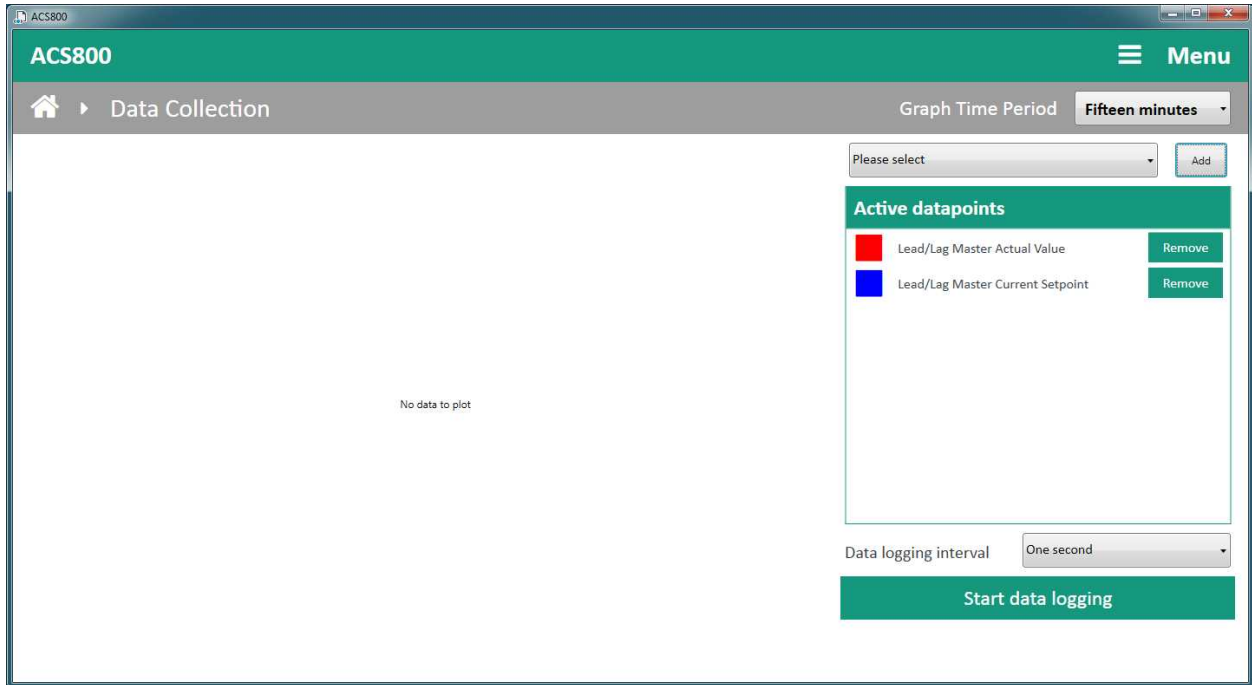

ACS800 Software (continued)

To remove a data point, click **Remove**. Choose the time period to display on the graph and the data logging interval desired, then click **Start data logging**.

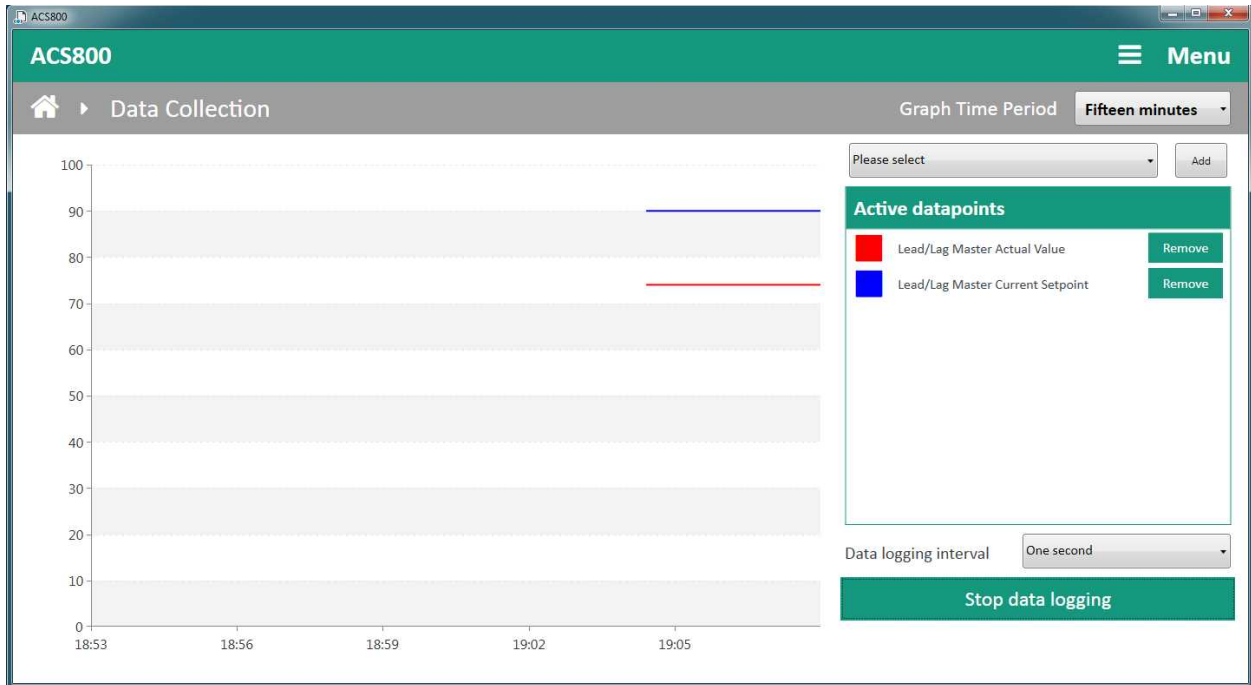

To stop the data logging, click **Stop data logging**. The data will be available for export until another data log is initiated. A data log will only continue logging if the ACS800 software is running and the log is active.

ACS800 Software (continued)

System Configuration

Specify the device to connect from this screen. Diagnostic information for the software is also shown on this screen. A password is required to access this screen. The default password is "SCC".

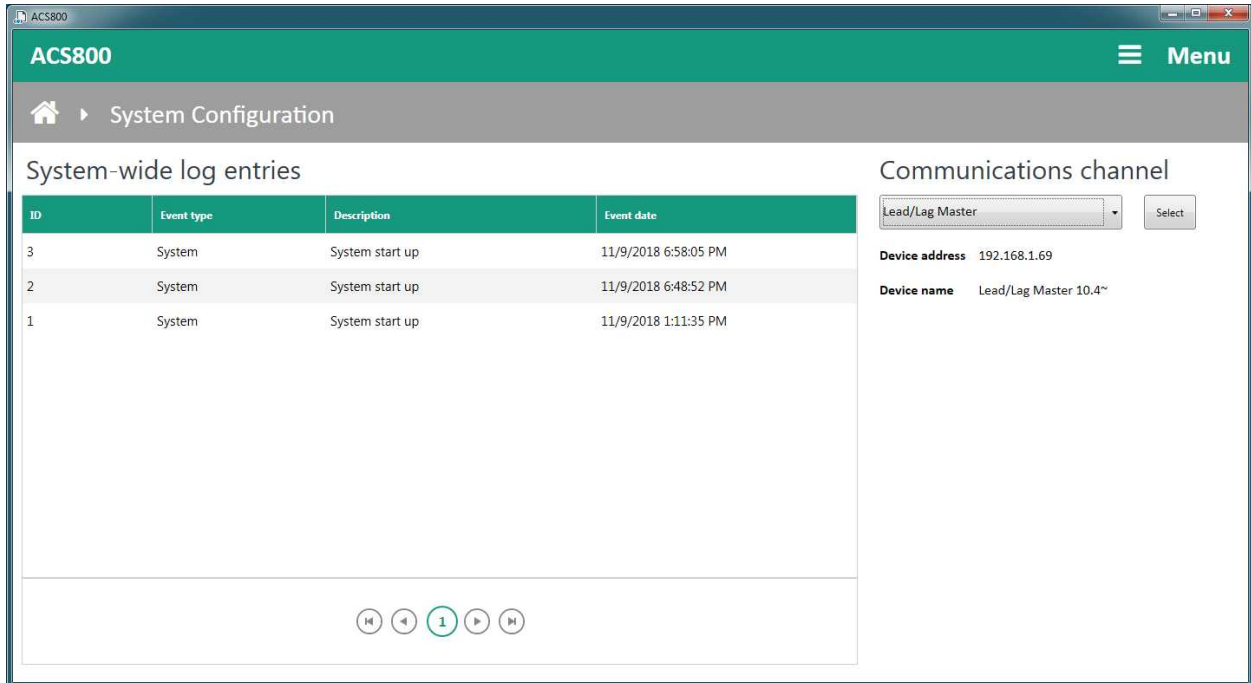

The screenshot displays the ACS800 System Configuration web interface. The page title is 'ACS800' and the breadcrumb is 'System Configuration'. The main content area is divided into two sections:

- System-wide log entries:** A table with the following data:

ID	Event type	Description	Event date
3	System	System start up	11/9/2018 6:58:05 PM
2	System	System start up	11/9/2018 6:48:52 PM
1	System	System start up	11/9/2018 1:11:35 PM
- Communications channel:** A configuration section with a drop-down menu set to 'Lead/Lag Master' and a 'Select' button. Below the menu, the 'Device address' is '192.168.1.69' and the 'Device name' is 'Lead/Lag Master 10.4~'.

At the bottom of the log entries section, there are navigation buttons: Home, Previous, Current (highlighted), Next, and End.

Choose the device to connect in the drop-down menu under the **Communications channel** tab. Choose **Lead/Lag Master** to connect that device if it uses the default IP address of 192.168.1.69. If the Lead/Lag Master uses a different IP address, choose **Other** from the menu and enter the IP address desired. Click **Update** to identify the remote device. Once the device is connected, click **Submit** to complete the connection.

ACS800 Software (continued)

Export Data

Data collected during data logging can be exported. To export, click **Choose file name and destination** to select the file location to save to, then click **Export data** to write the file. The number of records exported will be displayed.

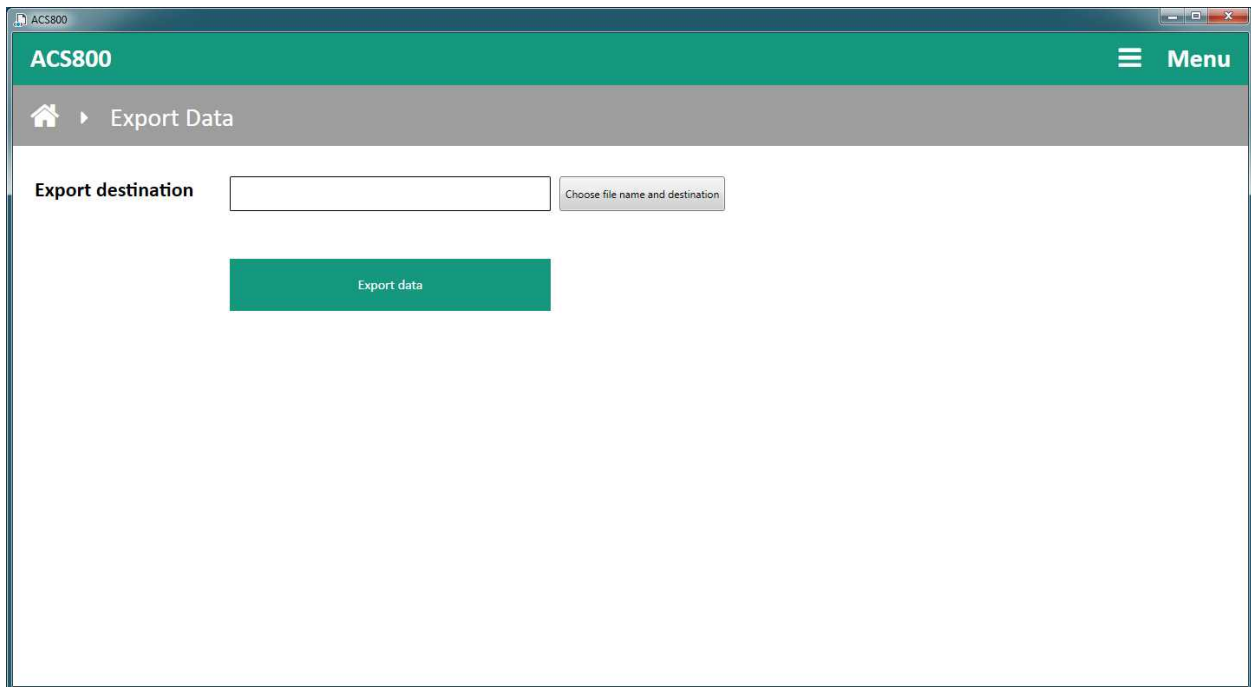

The format of the file is xlsx, which is a Microsoft Excel file format. Use a spreadsheet application that can open this type of file to view the data. Use the spreadsheet application to parse or graph this data as needed.

	A	B	C	D	E
1	SCC Inc. Datalog				
2					
3					
4					
5					
6	Date	Time	Lead/Lag Master Actual Value	Lead/Lag Master Current Setpoint	
7	11/9/2018	19:04:28	74	90	
8	11/9/2018	19:04:29	74	90	
9	11/9/2018	19:04:30	74	90	
10	11/9/2018	19:04:31	74	90	
11	11/9/2018	19:04:32	74	90	

ACS800 Software (continued)

Starting From Command Line

A viewer-only version can be started from a shortcut or the command line. This allows having an icon that will open a dedicated viewer when opened. This can also be linked from another external application or batch file. Multiple viewers can be opened simultaneously using this method.

To use, locate the viewer-only version of the software in the installed folder (normally located at C:\Program Files (x86)\SCC Inc\ACS800). The name of the file is ACS800Viewer.exe. The command line switch for opening the viewer is "ACS800Viewer /address xxx.xxx.xxx.xxx", where xxx.xxx.xxx.xxx denotes the IP address.

To create a shortcut, navigate to the ACS800Viewer.exe icon and right-click. Choose **Create shortcut**. The shortcut can be renamed by right-clicking and choosing **Rename**. To add the command line options to the shortcut, right-click and choose **Properties**.

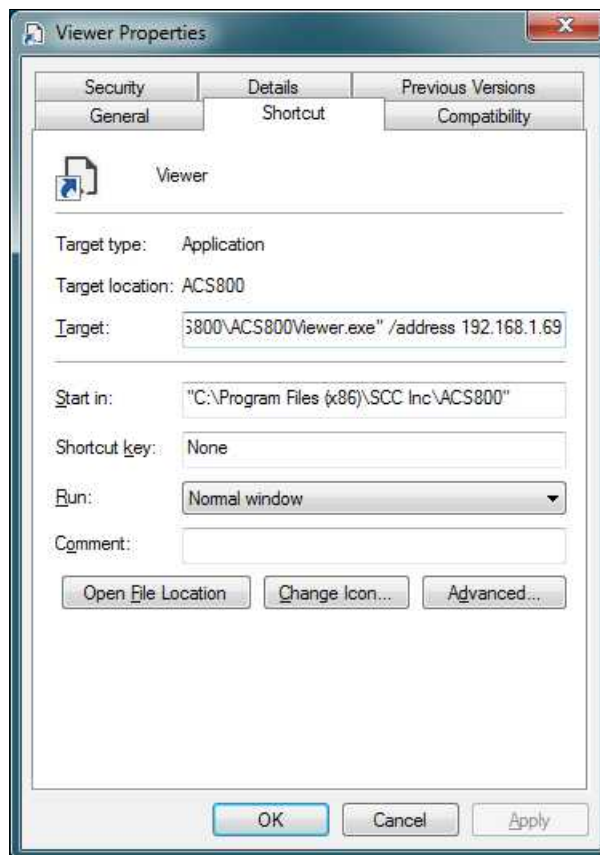

Once created, the icon can be moved to the Desktop or any other desired location. The shortcut itself can be copied, renamed and edited to change the IP address for creating shortcuts to other touchscreens.

Remote Monitoring via Android or iOS Devices

Remote monitoring of a touchscreen is possible using an Android or iOS device (phone or tablet). The touchscreen display can be viewed or manipulated as if the user was at the actual touchscreen (in real time). To establish a connection, the phone or tablet must be connected to the same network as the touchscreen. This requires that the network for the touchscreen contain a wireless access point.

To download the app, search for **Vijeo Design'Air** in the Google Play Store or Apple App Store. Once downloaded, open the app.

Once open, the app will automatically search for available devices. Touching 'Add Device' will allow the IP address of the desired touchscreen to be manually entered.

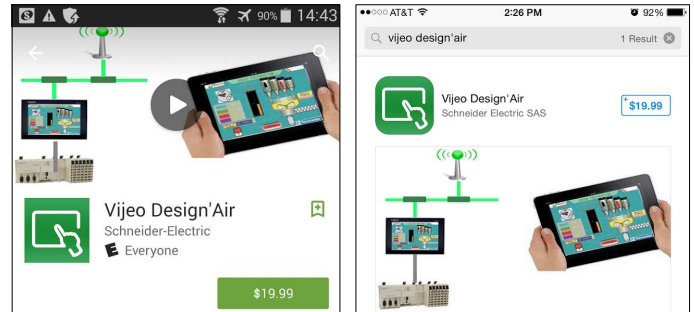

Navigate to the gear icon to change settings.

Note that when 'View-Only' is selected, an icon appears on the top right corner of the screen. Selecting 'Keep awake while connected' will keep the screen lock from activating.

Touch the device to connect to. Acknowledge the warning shown if remote control is desired, then touch 'OK'. If view-only access is desired, touch 'View-Only'.

The remote device is now connected. If remote control was enabled, touching the display will manipulate the touchscreen remotely, otherwise a message will appear stating that 'View-Only' mode was selected.



Touching the camera icon will allow the screen image to be saved.

Change Log

Revision 18D1

- Option to connect RWF55 only as load controller when connected serially.
- Option to send enable to RWF55 when limit string needs to break for an external interlock.
- Custom lead/lag order can be set when using time-based alternation.
- Boilers can be skipped as lead if desired.
- Lead shutoff can be based on exceeding a specific setpoint relative to the system setpoint.
- The maximum number of boilers that can be run simultaneously can be selected.
- Pump alarming can be disabled.
- Pump alarm time can be adjusted (alarms if not proven in allowed time).
- If there are less than five boilers two pump outputs with separate on-delays are available, usually used when a pump and isolation valve are both used (shared off-delay time).
- Option for internal storage of backup (does not survive reprogramming – use USB or SD).
- User values can be custom scripts (10"/12") or redirection of selected Modbus points (all sizes).
- Boiler points to Modbus re-written to include all EA analog and user values.

Change Log (continued)

Revision 18J1

- Email shortcuts and special characters now supported.
- RWF40 removed as option for load control or feedwater.
- Boiler available logic changed when using LMV5x/RWF55 load controller option.
- Added six digital inputs that can be used with monitored outputs or BMS.
- Added four free registers that can be used with monitored outputs or BMS.
- Totalization accuracy improved.
- Support for metric header (bar).
- Outside air reset can be disabled so having an outside air sensor for display only is possible.
- Outside air reset can now be enabled for steam systems.
- Outside air changeover to W2 is possible.
- Boiler rotation order, rotation skip and max to run set separately for W1 and W2.
- Pump control for hydronic systems can now be specified for use with isolation valves. This eliminates the pump graphics and replaces them with valve open or closed text.
- Pump or valve logic can be specified to be fail to run or fail to off.
- If there are less than five boilers isolation valve closed status can be annunciated.
- A loop control has been added for use with a valve, external device or a set of two pumps. Pump control can be wired or use Modbus. When wired, monitored outputs are used. Modbus is not limited to any specific VSD as setup is required to enter Modbus specifics.
- Added Delta (model C2000 tested) VSD as option for VSD display.
- Added ACS800 software instructions.

Revision 18J2

- Pt100 removed as RTD option.
- Open safety limit annunciates as lockout on LMV3.
- Error code 200 (No Error) parsed from fault annunciation.

Information in this publication is based on current specifications. The company reserves the right to make changes in specifications and models as design improvements are introduced. Product or company names mentioned herein may be the trademarks of their respective owners. © 2019 SCC Inc.