

SIEMENS



LMV37.4...

Basic unit with integrated air-fuel ratio control for forced draft burners

Basic Documentation

The LMV37.4... and this Basic Documentation are intended for OEMs which integrate the units in their products!

Software version
V03.40

CC1P7546en
20.04.2016

Building Technologies Division

Supplementary documentation

User Documentation Modbus AZL2.....	A7541
Environmental Product Declaration LMV2... / LMV3.....	E7541
Installation and Operating Instructions PC Software ACS410	J7352
Data 'Sheet LMV37.4.....	N7546
Product Range Overview LMV2... / LMV3.....	Q7541

Contents

1	Safety notes	10
1.1	Warning notes	10
1.2	Mounting notes	11
1.3	Installation notes.....	12
1.4	Electrical connection of the LMV37.4.....	13
1.5	Electrical connection of flame detectors.....	14
1.6	Commissioning notes	14
1.7	Notes on settings and parameter settings	16
1.8	Standards and certificates	17
1.9	Service notes.....	17
1.10	Life cycle.....	18
1.11	Disposal notes	18
2	System structure/function description	19
2.1	For Europe.....	19
2.2	For North America	19
2.3	General information	20
3	Type summary	20
4	Technical Data	21
4.1	Basic unit LMV37.4.....	21
4.1.1	Terminal loading «Inputs»	21
4.1.2	Terminal loading «Outputs»	22
4.1.3	Analog output / load output X74 pin 3	24
4.1.4	Cable lengths.....	24
4.1.5	Cross-sectional areas.....	24
4.1.6	Connections of actuators.....	24
4.2	Signal cable AGV50... from AZL2... → BCI	25
4.3	Environmental conditions	25
4.4	Flame detector.....	26
4.4.1	Ionization probe	26
4.4.2	UV flame detectors QRA2 / QRA4 / QRA10.....	28
4.4.3	Photoresistive flame detectors QRB.....	29
4.4.4	Blue-flame detectors QRC.....	30
5	Dimensions	31
5.1	LMV37.4.....	31
6	Display and diagnostics	32
7	Basic unit	33
7.1	Description of inputs and outputs	33
7.2	Flame detectors.....	34
7.2.1	Loss of flame	35
7.2.2	Extraneous light.....	36
7.2.3	No flame at the end of safety time 1 (TSA1)	36

7.2.4	Flame intensity.....	36
7.2.5	Supervision of flame detector	36
7.3	Digital inputs	37
7.3.1	Safety loop X3–04 pin 1 and 2.....	37
7.3.2	(Burner flange) X3–03, pin 1 and 2.....	38
7.3.3	Input for external controller (ON / OFF) X5–03, pin 1	38
7.3.4	Inputs X5-03 pin 2 and 3 (Open / Close or stage 2 / stage 3).....	38
7.3.5	Air pressure switch (APS) X3–02.....	39
7.3.6	Gas pressure switch valve proving (P LT) – or heavy oil direct start X9-04 ..	40
7.3.7	Gas / oil pressure switch-min (Pmin), start release gas X5–01	42
7.3.8	Setting the time for making the pressure switch test	43
7.3.9	Gas / oil pressure switch-max (Pmax) / or POC contact, start release oil X5– 02	44
7.3.10	Reset X8-04, pin 1	46
7.4	Digital outputs	47
7.4.1	Output alarm type No-SI – X3–05, pin 2	47
7.4.2	Fan motor contactor type SI – X3–05, pin 1	47
7.4.3	Fan continuous purging X3–05, pin 3	47
7.4.4	Output ignition (Z) type SI (IGNITION) X4–02	48
7.4.5	Outputs fuel valves type SI (V1...V3 / PV) X8–02, X7-01, X7-02.....	49
7.4.6	Output safety valve (SV) type SI X6–03	49
7.4.7	Output for indication of operation X8-04, pin 2	49
7.5	Program sequence.....	50
7.5.1	Time parameters.....	50
7.5.2	Valve proving	51
7.5.2.1.	Valve proving with separate pressure switch (P LT) X9-04	52
7.5.2.2.	Valve proving via gas pressure switch-min X5-01	53
7.5.2.3.	Lockout phase (phase 00)	53
7.5.2.4.	Safety phase (phase 01).....	54
7.5.3	Special functions during the program sequence.....	55
7.5.3.1.	Reset / manual lockout	55
7.5.3.2.	Alarm upon start prevention.....	56
7.5.3.3.	Possible start preventions.....	57
7.5.3.4.	Repetition counter.....	57
7.5.3.5.	Start without prepurging (as per EN 676)	60
7.5.3.6.	Gas shortage program	60
7.5.3.7.	Program stop function.....	61
7.5.3.8.	Forced intermittent operation (<24 hours)	61
7.5.3.9.	Low-fire shutdown.....	61
7.5.3.10.	Continuous fan.....	62
7.5.3.11.	Test function for approval of burner – loss-of-flame test (TÜV test)	63
7.5.3.12.	Purging in the lockout position	64
7.5.3.13.	Switching back to pilot	65
7.6	Fuel trains (application examples)	68
7.7	Sequence diagrams.....	77
7.7.1	Gas direct ignition «G», «G mod», «G mod pneu».....	78
7.7.2	Gas pilot ignition 1 «Gp1», «Gp1 mod», «Gp1 mod pneu»	79
7.7.3	Gas pilot ignition 2 «Gp2», «Gp2 mod», «Gp2 mod pneu»	80
7.7.4	Light oil direct ignition «Lo», «Lo mod», «Lo 2-stage», «Lo 3-stage»	81

7.7.5	Light oil pilot ignition «Lo Gp»	82
7.7.6	Heavy oil direct ignition «HO», «HO m. Umsp mod», «HO m. Umsp 2-stage» with separate circulation control	83
7.7.7	Heavy oil direct ignition «HO», «HO o. Umsp mod», «HO o. Umsp 2-stage», «HO o. Umsp 3-stage» without separate circulation control	84
7.7.8	Legend to the sequence diagrams	85
8	Selection of operating mode	88
8.1	Deleting curves	90
9	Connection to load controllers	91
9.1	Controller on contact X5-03 pin 1	91
9.2	External load controller via contacts X5-03, pin 2 / pin 3	91
9.3	Default output via building automation – X92	94
9.4	Manual output	95
9.5	Output with curve settings	95
9.6	External load controller via analog input X64 pin 1 / X64 pin 2	96
9.6.1	Switching thresholds for modulating operation	96
9.6.2	Switching thresholds for multistage operation	97
9.7	Prioritization of load sources	98
9.7.1	Emergency operation with several load controllers	98
9.7.2	Manual control	98
10	Electronic air-fuel ratio control	99
10.1	General	99
10.2	Behavior outside the operating positions	99
10.2.1	Traveling speed	99
10.2.2	Home position	99
10.2.3	Prepurging	100
10.2.4	Ignition	100
10.2.5	Postpurging	100
10.3	Modulating operation	101
10.3.1	Definition of curves	101
10.3.2	Traveling speed / maximum curve slope	102
10.3.3	Entering the running position	103
10.3.4	Operating position	103
10.3.5	Limitation of modulation range	104
10.3.6	Setting the minimum and maximum output	105
10.4	Multistage operation	106
10.4.1	Definition of curves	106
10.4.2	Traveling speed	106
10.4.3	Adjustment of output	107
10.4.4	Entering the operating position	107
10.4.5	Operating position	107
10.4.6	Limitation of modulation range	108
10.5	End of operating position	108
10.6	Notes on settings and parameter settings	109
11	Actuators X53 / X54	110

11.1	Function principle	110
11.2	Definition of angles	110
11.3	Referencing.....	111
11.3.1	Reference travel.....	112
11.4	Direction of rotation.....	114
11.5	Monitoring the actuator positions	115
11.6	Changing the error detection band for monitoring the actuator positions	117
11.7	Forced travel	117
11.8	Detection of line interruptions	117
11.9	Protection against actuator mixup.....	118
11.9.1	Proposal for implementation	118
12	Fan control	119
12.1	Function principle.....	119
12.2	Activation of VSD/PWM fan	119
12.3	VSD control X74 pin 3.....	120
12.4	PWM fan control X64 pin 3	120
12.5	Safe separation of mains voltage and protective extra low-voltage.....	121
12.6	Ramp time.....	121
12.7	Acquisition of speed.....	122
12.7.1	Acquisition of speed with proximity switch	122
12.7.2	Acquisition of speed with Hall generator.....	123
12.8	Speed control.....	124
12.9	Speed supervision	125
12.10	Setting the parameters of VSD	126
12.11	Standardization of speed	127
12.12	Control of fan motor with pneumatic air-fuel ratio control	130
12.13	EMC of LMV37.4... and VSD	130
12.14	Description of connection terminals	131
12.14.1	VSD.....	131
12.14.2	PWM fan	131
13	Load output X74 pin 3	132
13.1	Safe separation of mains voltage and extra low-voltage	132
13.2	Modulating operation	132
13.3	2-stage operation	132
13.4	3-stage operation	133
14	Fuel meter input X75 pin 1 / X75 pin 2	134
14.1	Configuration of fuel meter.....	134
14.1.1	Types of fuel meters	134
14.1.2	Configuration of pulses per volume unit.....	134
14.1.3	Reading and resetting the meter readings.....	134
14.2	Fuel throughput.....	135
14.2.1	Configuration.....	135
14.2.2	Reading out the fuel throughput.....	135

15	Connection and internal diagram	136
16	Special feature: Burner identification (ID).....	137
17	Connection to superposed systems.....	137
17.1	General information and building automation functions	137
17.2	Modbus.....	139
18	PC software ACS410	140
19	Error history.....	141
19.1	Error classes.....	141
19.2	Makeup of error history.....	142
20	Lifecycle function.....	142
21	Safety notes on use of the AZL2... ..	143
22	Operating the AZL2... unit.....	144
22.1	Description of unit/display and buttons.....	144
22.2	Meaning of symbols on the display	145
22.3	Brightness of display	145
22.4	Special functions	146
22.4.1	Manual lockout	146
22.4.2	Manual control (manual request for output).....	146
22.5	Timeout for menu operation	147
22.6	Backup / restore	148
22.6.1	Backup.....	149
22.6.2	Restore.....	151
23	Operation of basic unit via the AZL2... ..	153
23.1	Normal display.....	153
23.1.1	Display in standby mode	153
23.1.2	Display during startup / shutdown	153
23.1.2.1.	Display of program phases.....	153
23.1.2.2.	Display of program phase with remaining running time until end of the phase is reached.....	153
23.1.2.3.	List of phase displays	154
23.1.3	Display of operating position	155
23.1.4	Fault status message, display of errors and info	156
23.1.4.1.	Display of errors (faults) with lockout.....	156
23.1.4.2.	Reset	156
23.1.4.3.	Activating info / service mode from lockout	156
23.1.4.4.	Error with safety shutdown	157
23.1.4.5.	General information	157
23.1.4.6.	Start prevention	157
23.1.4.7.	Safety loop.....	157
24	Menu-driven operation.....	158
24.1	Assignment of levels.....	158
25	Info level.....	159

25.1	Display of info level.....	160
25.2	Display of info values (examples)	160
25.2.1	Identification date.....	160
25.2.2	Identification number.....	160
25.2.3	Burner identification	161
25.2.4	Number of startups resettable.....	161
25.2.5	Total number of startups	162
25.2.6	End of info level	162
26	Service level	163
26.1	Display of service level	163
26.2	Display of service values (example)	164
26.2.1	Number of faults.....	164
26.2.2	Error history	164
26.2.3	Intensity of flame.....	164
26.2.4	End of service level.....	164
27	Parameter level	165
27.1	Entry of password	166
27.2	Entry of burner identification	168
27.3	Change of heating engineer's password.....	169
27.4	Change of OEM's password	170
27.5	Use of parameter level.....	170
27.6	Structure of parameter levels.....	171
27.7	Parameters without index, with direct display	172
27.7.1	Using the example of parameter 208: Program stop	172
27.8	Parameters without index, with no direct display (with parameters having a value range >5 digits)	174
27.8.1	Using the example of parameter 162: Operating hours resettable	174
27.9	Parameter with index, with direct display.....	176
27.9.1	Using the example of parameter 501: No-flame positions fuel actuator	176
27.10	Parameters with index, with no direct display	178
27.10.1	Using the example of parameter 701: Errors	178
27.11	Air-fuel ratio curves – settings and commissioning.....	181
27.11.1	Initial commissioning.....	181
27.11.2	Setting curvepoints P0 and P9 for modulating mode («G mod», «Gp1 mod», «Gp2 mod» and «Lo mod»).....	184
27.11.3	Setting curvepoints P0 and P9 for «G mod pneu», «Gp1 mod pneu» and «Gp2 mod pneu»	186
27.11.4	Warm settings for modulating mode («G mod», «Gp1 mod», «Gp2 mod» and «Lo mod» and «Ho mod»).....	187
27.11.5	Warm settings for modulating mode («G mod pneu», «Gp1 mod pneu» and «Gp2 mod pneu»).....	192
27.11.6	Cold settings for «G mod», «Gp1 mod», «Gp2 mod» and «Lo mod» and «Ho mod»	192
27.11.7	Cold settings for «G mod pneu», «Gp1 mod pneu» and «Gp2 mod pneu».....	192
27.11.8	Editing the curvepoints.....	193
27.11.9	Interpolation of curvepoints.....	194

27.11.10	Setting of curvepoints for multistage mode («Lo 2-stage», «Lo 3-stage», «Ho 2-stage» and «Ho 3-stage»)	197
27.11.11	Warm settings for «Lo 2-stage», «Lo 3-stage», «Ho 2-stage» and «Ho 3-stage»	198
27.11.12	Cold settings for multistage mode («Lo 2-stage», «Lo 3-stage», «Ho 2-stage» and «Ho 3-stage»)	202
27.11.13	Intensity of flame during curve settings	202
28	Parameter list LMV37.4...	203
29	Error code list	215
30	Revision history of basic unit LMV37.4...	228
31	List of figures	232

1 Safety notes

1.1 Warning notes



To avoid injury to persons, damage to property or the environment, the following warning notes must be observed!

LMV37.4... are safety devices! Do not open, interfere with or modify the units. Siemens does not assume responsibility for damage resulting from unauthorized interference!

The chapters covering the LMV37.4... contain additional warning notes which should also be observed when using the different unit versions!

After commissioning and after each service visit, check the flue gas values across the entire output range!

The present Basic Documentation describes a wide choice of applications and functions and shall serve as a guideline. The correct functioning of the units is to be checked and proven by function checks on a test rig or on the plant itself!

- All activities (mounting, installation and service work, etc.) must be performed by qualified personnel
- Degree of protection IP40 as per DIN EN 60529 for the basic unit must be ensured through adequate mounting of the LMV37.4... by the burner or boiler manufacturer
- Before making any wiring changes in the connection area, completely isolate the plant from mains supply (all-polar disconnection). Ensure that the plant cannot be inadvertently switched on again and that it is indeed dead. If not disconnected, there is a risk of electric shock hazard
- Protection against electric shock hazard on the LMV37.4... and on all connected electrical components must be ensured through adequate mounting. In terms of design, stability and protection, the cover used must conform to EN 60730
- After each activity (mounting, installation and service work, etc.), check to ensure that wiring is in an orderly state and that the parameters are correctly set
- Fall or shock can adversely affect the safety functions. Such units must not be put into operation even if they do not exhibit any damage
- When programming the air-fuel ratio control curves, the commissioning engineer must constantly watch the quality of the combustion process (e.g. by means of a flue gas analyzer) and, in the event of poor combustion values or dangerous conditions, take appropriate actions, e.g. by shutting down the system manually
- The following plug-on terminations carry FELV (Functional Extra Low-Voltage) (also refer to chapter *Electrical connection of the LMV37.4...*) which means that they do not provide safe separation from mains voltage:
 - The BCI (X56) for the connecting cable of the AZL2... or PC software ACS410
 - COM (X92) for accessories, such as the OCI410...These plug-on terminations may be removed or replaced only when the plant is dead (all-polar disconnection)
- The connectors of the connecting cables for the LMV37.4... or other accessories, such as the OCI410... (plugged into the BCI), may only be removed or exchanged when the plant is shut down (all-polar disconnection), since the BCI interface does not provide safe separation from mains voltage
- The connections for the SQM3... or SQN1... actuators do not provide safe separation from mains voltage. Prior to connecting or changing one of these actuators, the plant must be shut down (all-polar disconnection)

To ensure safety and reliability of the LMV37.4... system, the following points must also be observed:

- Condensation and ingress of humidity must be avoided. Should such conditions occur, make sure that the unit is completely dry before switching on again!
- Static charges must be avoided since they can damage the unit's electronic components when touched.

Recommendation: Use ESD equipment

- If the unit fuse was blown due to overload or a short-circuit at the connection terminals, the LMV37.4... must be replaced since the switching contacts might have been damaged
- If error codes 95...98 appear during operation, this may be an indication of contact problems and the LMV37.4... should be replaced

1.2 Mounting notes

- Ensure that the relevant national safety regulations and standard notes are complied with
- In geographical areas where DIN regulations are in use, the requirements of VDE must be satisfied, especially DIN / VDE 0100, 0550 and DIN / VDE 0722
- The LMV37.4... basic unit must be secured with fixing screws M4 (UNC32) or M5 (UNC24), observing a maximum tightening torque of 1.8 Nm and using all 4 fixing points. The additional mounting surfaces on the housing are provided to improve mechanical stability. These must fully rest on the mounting surface to which the unit is secured. The flatness of that mounting surface must be within a tolerance band of 0.3 mm

Note on mounting

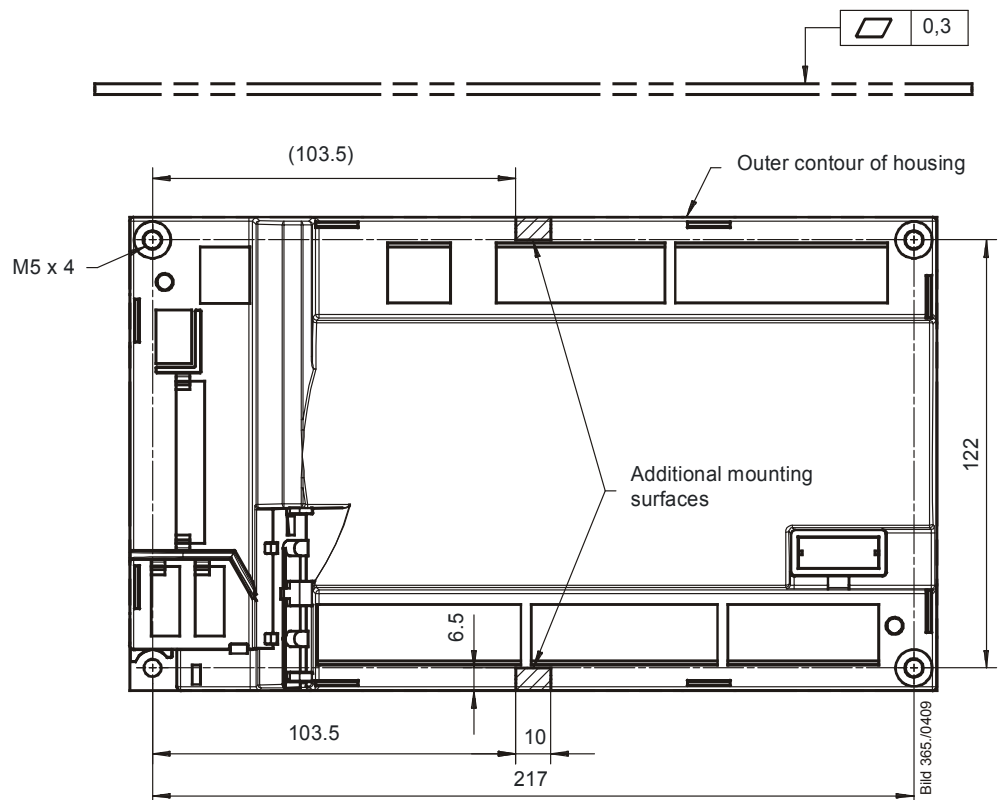

Figure 1: Note on mounting

1.3 Installation notes

- Always run the high-voltage ignition cables separate from the unit and other cables while observing the greatest possible distances
- Ensure that the electrical wiring inside the boiler is in compliance with national and local safety regulations
- Mains power must always be supplied via *L* and *N*. This means that no potential differential must exist between the neutral conductor *N* and protective earth *PE*
- Phase and neutral conductor must not be interchanged (dangerous malfunctions, loss of protection against electric shock hazard, etc.)
- Make certain that strain relief of the connected cables is in compliance with the relevant standards (e.g. as per DIN EN 60730 and DIN EN 60335)
- Ensure that spliced wires cannot get into contact with neighboring terminals. Use adequate ferrules
- Run the high-voltage ignition cable completely separate from all other cables
- The burner manufacturer must protect unused terminals of the LMV37.4... by fitting dummy plugs (exception: X64 (reserve) and X74)
- When making the wiring, the AC 120 V or AC 230 V section must be strictly separated from other voltage sections, thus ensuring protection against electric shock hazard. For more detailed information, refer to chapter *Electrical connection of the LMV37.4...*
- The connectors of the connecting cables for the LMV37.4... may only be removed or exchanged when the plant is turned off (all-polar disconnection), since the BCI interface does not provide safe separation from mains voltage
- AGV50... signal cable between LMV37.4... and AZL2...
Since the BCI carries FELV (refer to chapter *Electrical connection of the LMV37.4...*), the connection between LMV37.4... and AZL2... must be established via the AGV50... signal cable, or by ensuring compliance with the specification. The signal cable is specified for use under the burner hood. When using other types of signal cable that do not meet the specification requirements, safety against electric shock hazard is not necessarily ensured
- Do not lay signal cable AGV50... from the LMV37.4... to the AZL2... together with other cables
- Service operation with a longer signal cable from the LMV37.4...:
If a longer signal cable is required for service work for example (short-time usage, <24 hours), note that the above application under the burner hood no longer applies and, for this reason, the signal cable can be subjected to increased mechanical stress. In that case, use a reinforced signal cable
- Both the AGV50... signal cable and the AZL2... must be shipped and stored so that no damage due to dust and water can occur when the products are used in the plant
- To ensure protection against electric shock hazard, make certain that, prior to switching on power, the AGV50... signal cable is correctly connected to the AZL2...
- The AZL2... must be used in a dry and clean environment
- The mechanical coupling between the actuators and the controlling elements for fuel and air, or any other controlling elements, must be rigid

1.4 Electrical connection of the LMV37.4...

The LMV37.4... operates with the following low-voltages:

- SELV (Safety Extra Low-Voltage) and PELV (Protective Extra Low-Voltage) ensure protection against electric shock hazard
- FELV (Functional Extra Low-Voltage) without safe separation offers no protection which, in the event of fault, would not exclude risks

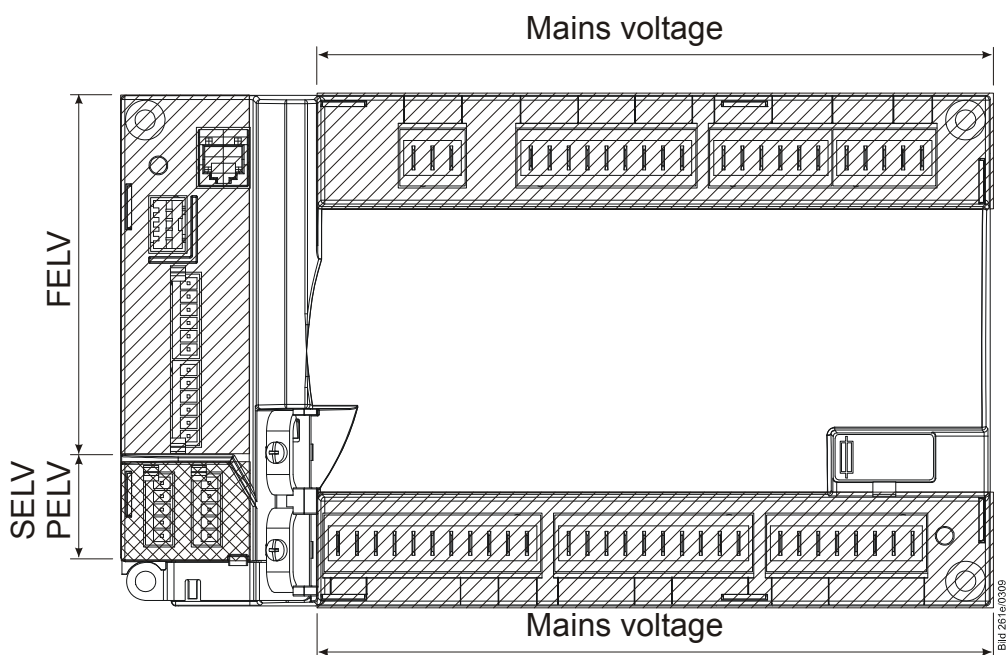

Figure 2: Electrical connection



Note

SELV or PELV depends on the safety class of the connected components. In the case of PELV, the relevant component is connected to protective earth.

1.5 Electrical connection of flame detectors

It is important to achieve practically disturbance- and loss-free signal transmission:

- Never run the detector cables together with other cables
 - Line capacitance reduces the magnitude of the flame signal
 - Use a separate cable
- Observe the permissible detector cable lengths
- The mains-powered ionization probe is not protected against electric shock hazard. It must be protected against accidental contact
- Earth the burner in compliance with the relevant regulations; earthing the boiler alone does not suffice
- Locate the ignition electrode and the ionization probe such that the ignition spark cannot arc over to the ionization probe (risk of electrical overloads)

1.6 Commissioning notes

- When commissioning the unit, check **all safety functions**
- There is no absolute protection against incorrect use of the RASTx connectors. For this reason, prior to commissioning the plant, check the correct assignment of all connectors
- Electromagnetic emissions must be checked on an application-specific basis

After the plant has been installed and commissioned, the person responsible for the plant / heating engineer must **document** the parameterized values and settings (e.g. curve characteristics) used for air-fuel ratio control.

These data can be printed out with the help of the ACS410 PC software, for example, or must be written down.

This document must be kept in a safe place and checked by the expert.



Caution!

On the OEM level of the LMV37.4..., parameter settings other than those specified in the application standards can be made. For this reason, check whether the parameter settings made are in compliance with the relevant application standards (e.g. EN 676, EN 267, etc.), or whether the respective plant demands special approval!

Air-fuel ratio
control system

The selected setting values of fuel and combustion air must be assigned such that – while giving consideration to the combustion chamber / fuel pressure, temperature and combustion air pressure, as well as wear of actuators and controlling elements, etc. – correct operation with sufficient amounts of excess air is ensured across the burner's full output range for an extensive period of time (until the next regular inspection is due; also refer to chapter *Monitoring the positions*). This must be proven by the burner / boiler manufacturer by measuring the characteristic combustion process values. If the standardization process is repeated, the air-fuel ratio control system must be rechecked.

Basic unit section

Prior to commissioning the system, the following points must be checked:

- Parameterization of operating mode (e.g. «G mod», «Gp1 mod», «Lo mod», etc.) must accord with the type of burner used (refer to chapter *Selection of operating mode*)
- Correct assignment of the valves to the valve outputs of the LMV37.4...
- Correct setting of the time parameters, especially the safety and prepurge times
- Correct functioning of the flame detector in the event of loss of flame during operation (including the response time), with extraneous light, during the prepurge time and, when there is no establishment of flame, at the end of the safety time
- Activation of the valve proving function and determination of the correct leakage rate, if required by the application (refer to chapter *Valve proving*)

The functions of the following available or required input status signals must be checked:

- Air pressure
- Minimum gas pressure / maximum gas pressure or POC
- Gas pressure valve proving
- Minimum oil pressure and maximum oil pressure
- Safety loop (e.g. safety limiter)

Duties of the expert when making the approval tests

	Action	Check / response
a)	Burner startup with flame detector darkened	Lockout at the end of safety time 1 (TSA1)
b)	Burner startup with flame detector exposed to extraneous light, e.g. to incandescent light with detectors for visible radiation, quartz-halogen bulb or cigarette lighter flame with detectors for UV radiation	Lockout at prepurge time (t1)
c)	Simulation of loss of flame during operation. For that, darken the flame detector in the operating position and maintain that state	Lockout or restart, depending on the basic unit's configuration
d)	Check the plant's response time with loss of flame during operation. For that purpose, manually disconnect the fuel valves from power and check the time from this moment the basic unit requires to turn off power to the valve	Turning off power to the valves by the basic unit within the period of time permitted for the respective type of plant
e)	Check the safe operation of the burner while giving consideration to system tolerances	<p>System tolerances are the result of a number of factors, such as:</p> <ul style="list-style-type: none"> - Tolerances of actuators plus mechanical linkage to the controlling elements - Environmental conditions (temperature, air conditions) - Type of fuel (calorific value / pressure) - Type of supply air path and flue ways <p>Example of procedure for checking the burner's response to actuator tolerances:</p> <ul style="list-style-type: none"> - Approach a output point in programming mode (e.g. low-fire or high-fire) - Change the actuator's position against the optimum fuel-air ratio setting as can be expected in the case of tolerances - Check the flue gas values with a flue gas analyzer <p>Recommendation: Make this readjustment against the optimum fuel-air ratio setting for one actuator at a time!</p>

Further checks may be required, depending on the field of use and the relevant standards.

1.7 Notes on settings and parameter settings

- When adjusting the electronic air-fuel ratio control system integrated in the LMV37.4..., allow for sufficient amounts of excess air since – over a period of time – the flue gas settings are affected by a number of factors (e.g. density of air, wear of actuators and controlling elements, etc.). For this reason, the flue gas values initially set must be checked at regular intervals
- To safeguard against inadvertent or unauthorized parameter transfer from the PC software to the basic unit, the OEM must assign an **individual burner identification** (ID) for each burner. Compliance with this regulation is mandatory to ensure that the LMV37.4... system prevents the transfer of parameter sets of some other plant (with inadequate and possibly dangerous parameter values) to the LMV37.4... system via the PC software. In addition, the air-fuel ratio control parameters must be manually approached and the combustion values checked
- With the LMV37.4... system, it is to be noted that the unit's characteristics are determined primarily by the specific parameter settings rather than the type of unit. This means that, among other things, each time a plant is commissioned, the parameter settings must be checked and the LMV37.4... must not be transferred from one plant to another without adapting the parameter settings to the new plant
- When using the ACS410 PC software, the safety notes given in the relevant Installation and Operating Instructions (J7352) must also be observed
- A password protects the parameter level against unauthorized access. The OEM allocates individual passwords to the setting levels he can access. The default passwords used by Siemens must be changed by the OEM. These passwords are confidential and may only be given to persons authorized to access such setting levels
- The responsibility for setting the parameters lies with the person who – in accordance with his access rights – made changes to the respective setting level

In particular, the OEM (burner and / or boiler manufacturer) assumes responsibility for the correct parameter settings in compliance with the standards covering the specific applications (e.g. EN 676, EN 267, EN 746-2, etc.).

1.8 Standards and certificates



Applied directives:

- Low-voltage directive 2014/35/EC
- Directive for gas-fired appliances 2009/142/EC
- Directive for pressure devices 97/23/EC and 2014/68/EC (2016-07-16)
- Electromagnetic compatibility EMC (immunity) *) 2014/30/EC

*) The compliance with EMC emission requirements must be checked after the burner management system is installed in equipment

Compliance with the regulations of the applied directives is verified by the adherence to the following standards / regulations:

- Automatic burner control systems for burners and appliances burning gaseous or liquid fuels DIN EN 298
- Safety and control devices for gas burners and gas burning appliances - Valve proving systems for automatic shut-off valves DIN EN 1643
- Gas/air ratio controls for gas burners and gas burning appliances - Part 2: Electronic types DIN EN 12067-2
- Safety and control devices for gas burners and gas burning appliances DIN EN 13611
- Safety and control devices for gas burners and gas-burning appliances - Particular requirements Part 1: Automatic and semi-automatic valves ISO 23552-1
- Automatic electrical controls for household and similar use Part 2-5: Particular requirements for automatic electrical burner control systems DIN EN 60730-2-5

The relevant valid edition of the standards can be found in the declaration of conformity!



Note on DIN EN 60335-2-102

Household and similar electrical appliances - Safety - Part 2-102: Particular requirements for gas, oil and solid-fuel burning appliances having electrical connections. The electrical connections of the LMV2 comply with the requirements of EN 60335-2-102.



EAC Conformity mark (Eurasian Conformity mark)



ISO 9001:2008
ISO 14001:2004
OHSAS 18001:2007

Type							
LMV37.400A1	---	---	---	•	•	•	•
LMV37.400A2	---	---	---	•	•	•	•
LMV37.420A1	•	•	•	•	•	•	•

1.9 Service notes

- **If fuses are blown, the unit must be returned to Siemens** (refer to chapter *Warning notes*)

1.10 Life cycle

The burner management system LMV3... has a designed lifetime* of 250,000 burner startup cycles which, under normal operating conditions in heating mode, correspond to approx. 10 years of usage (starting from the production date given on the type field). This lifetime is based on the endurance tests specified in standard EN 298. A summary of the conditions has been published by the European Control Manufacturers Association (Afecor) (www.afecor.org).

The designed lifetime is based on use of the basic unit according to the manufacturer's Basic documentation. After reaching the designed lifetime in terms of the number of burner startup cycles, or the respective time of usage, the basic unit is to be replaced by authorized personnel.

* The designed lifetime is not the warranty time specified in the Terms of Delivery

1.11 Disposal notes



The unit contains electrical and electronic components and must not be disposed of together with household waste. Local and currently valid legislation must be observed.

2 System structure/function description

The LMV37.4... is a microprocessor-based burner management system with matching system components for the control and supervision of forced draft burners of medium to high capacity.

Integrated in the basic unit of the LMV37.4... are:

- Burner management system complete with valve proving system
- Electronic air-fuel ratio control system for a maximum of 2 SQM3... or SQN1... actuators
- Control of VSD air fan
- Modbus interface

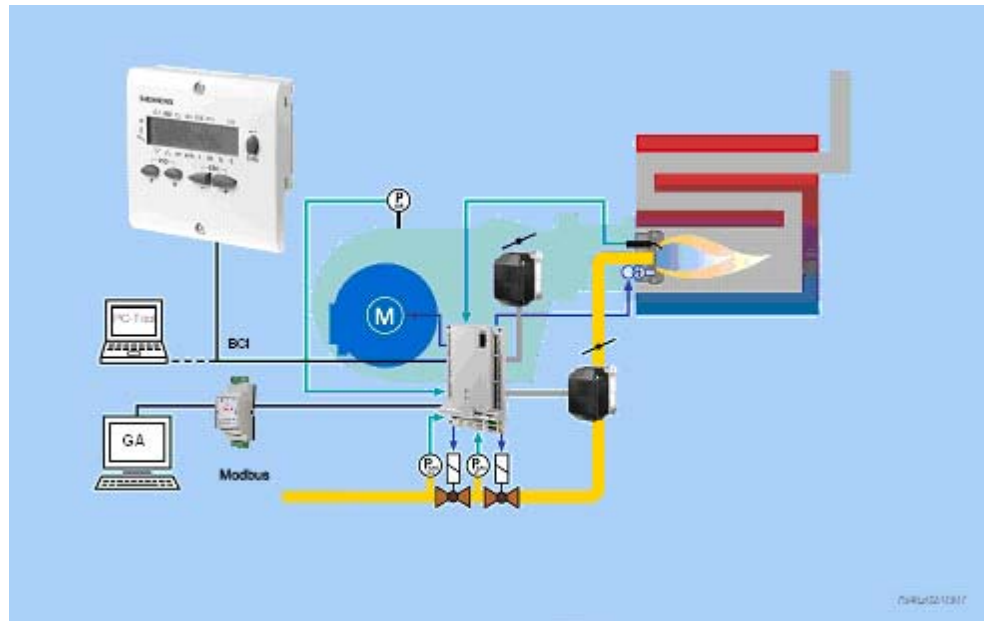

Figure 3: System structure

Example: Modulating gas burner

The system components (display and operating unit, actuators) are connected directly to the LMV37.4... basic unit. All safety-related digital inputs and outputs of the system are monitored by a contact feedback network.

2.1 For Europe

For intermittent operation in connection with the LMV37.4..., the ionization probe or the QRA..., QRB... or QRC... optical flame detectors can be used. **Continuous operation is possible only when using an ionization probe.**

2.2 For North America

For intermittent operation could in connection with the LMV37.4..., the ionization probe or the optical flame detector QRA... or QRB... can be used. **Continuous operation is possible only when using an ionization probe.**

2.3 General information

The burner management system is operated and parameterized either via the AZL2... display and operating unit or with the help of the PC software.

The AZL2... with LCD and menu-driven operation facilitates straightforward use and targeted diagnostics. When making diagnostics, the display shows the operating states, the type of error and the point in time the error occurred. Passwords protect the different parameter levels of the burner / boiler manufacturer and heating engineer against unauthorized access. There is also a COM port which can be accessed from a superposed system, such as a building automation and control system (BACS). A PC with ACS410 software can be connected via the BCI and OCI410... interface. Among other features, the ACS410 software affords convenient readout of settings and operating states, parameterization of the LMV37.4..., and trend recordings. The burner / boiler manufacturer can select from different types of fuel trains and make use of a wide choice of individual parameter settings (program times, configuration of inputs / outputs, etc.), enabling him to make optimum adaptations to the relevant application. The actuators are driven by stepper motors and can be positioned with high resolution. Specific features and actuator settings are defined by the LMV37.4... basic unit.

3 Type summary

Microprocessor-based basic unit for single-fuel burners of any capacity, with electronic air-fuel ratio control, up to 2 actuators, with integrated gas valve proving system.

Product no.	Mains voltage	Parameter set	Product no. of flame detector
LMV37.400A1	AC 120 V	Europe	QRA2 / QRA4 / QRA10 / QRB / ION
LMV37.400A2	AC 230 V	Europe	QRA2 / QRA4 / QRA10 / QRB / QRC / ION
LMV37.420A1	AC 120 V	North America	QRA4 / QRB / ION

4 Technical Data

4.1 Basic unit LMV37.4...

Mains voltage	
- LMV37.400A1, LMV37.420A1	AC 120 V -15 % / +10 %
- LMV37.400A2	AC 230 V -15 % / +10 %
Mains frequency	50 / 60 Hz \pm 6 %
Power consumption	<30 W (typically)
Safety class	I, with parts according to II and III to DIN EN 60730-1
Degree of protection	IP00

Note

The burner or boiler manufacturer must ensure degree of protection IP40 for the LMV37.4... as per DIN EN 60529 through adequate installation

4.1.1 Terminal loading «Inputs»

• Perm. mains primary fuse (externally)	Max. 16 AT
• Unit fuse F1 (internally)	6.3 AT (DIN EN 60127 2 / 5)
• Mains supply: Input current depending on the operating state of the unit	
Undervoltage	
• Safety shutdown from operating position at mains voltage	
- LMV37.400A1, LMV37.420A1	Approx. AC 93 V
- LMV37.400A2	Approx. AC 186 V
• Restart on rise in mains voltage	
- LMV37.400A1, LMV37.420A1	Approx. AC 96 V
- LMV37.400A2	Approx. AC 195 V
Status inputs: Status inputs (with the exception of the safety loop) of the contact feedback network (CFN) are used for system supervision and require mains-related input voltage	
• Input safety loop	Refer to <i>Terminal loading outputs</i>
• Input currents and input voltages	
- UeMax	UN +10 %
- UeMin	UN -15 %
- IeMax	1.5 mA peak
- IeMin	0.7 mA peak
• Contact material recommendation for external signal sources (LP, Pmin, Pmax, etc.)	Gold-plated silver contacts
• Transition / settling behavior / bounce	
- Perm. bounce time of contacts when switching on / off	Max. 50 ms (after the bounce time, contact must stay closed or open)
• UN	
- LMV37.400A1, LMV37.420A1	AC 120 V
LMV37.400A2	AC 230 V
• Voltage detection	
- On	
- LMV37.400A1, LMV37.420A1	AC 90...132 V
- LMV37.400A2	AC 180...253 V
- Off	
- LMV37.400A1, LMV37.420A1	<AC 40 V
- LMV37.400A2	<AC 80 V

4.1.2 Terminal loading «Outputs»

Total contact loading:

- Rated voltage
 - LMV37.400A1, LMV37.420A1 AC 120 V, 50 / 60 Hz
 - LMV37.400A2 AC 230 V, 50 / 60 Hz

 - Unit input current (safety loop) from: Max. 5 A
 - Fan motor contactor
 - Ignition transformer
 - Valves
 - Oil pump / magnetic clutch
-

Individual contact loading:

Fan motor contactor	
• Rated voltage	
- LMV37.400A1, LMV37.420A1	AC 120 V, 50 / 60 Hz
- LMV37.400A2	AC 230 V, 50 / 60 Hz
• Rated current	
- LMV37.400A1, LMV37.420A1	2 A
- LMV37.400A2	1,6 A pilot duty load declaration to UL372
• Power factor	$\text{Cos}\varphi > 0.4$
Alarm output	
• Rated voltage	
- LMV37.400A1, LMV37.420A1	AC 120 V, 50 / 60 Hz
- LMV37.400A2	AC 230 V, 50 / 60 Hz
• Rated current	1 A
• Load factor	$\text{Cos}\varphi > 0.4$
Ignition transformer	
• Rated voltage	
- LMV37.400A1, LMV37.420A1	AC 120 V, 50 / 60 Hz
- LMV37.400A2	AC 230 V, 50 / 60 Hz
• Rated current	
- LMV37.400A1, LMV37.420A1	2 A
- LMV37.400A2	1.6 A pilot duty load declaration to UL372 or 250 VA ignition load declaration to UL372
• Power factor	$\text{Cos}\varphi > 0.2$
Fuel valves	
• Rated voltage	
- LMV37.400A1, LMV37.420A1	AC 120 V, 50 / 60 Hz
- LMV37.400A2	AC 230 V, 50 / 60 Hz
• Rated current	
- LMV37.400A1, LMV37.420A1	2 A
- LMV37.400A2	1.6 A pilot duty load declaration to UL372
• Power factor	$\text{Cos}\varphi > 0.4$
Operation display	
• Rated voltage	
- LMV37.400A1, LMV37.420A1	AC 120 V, 50 / 60 Hz
- LMV37.400A2	AC 230 V, 50 / 60 Hz
• Rated current	0.5 A
• Power factor	$\text{Cos}\varphi > 0.4$
Safety valve (SV) (magnetic clutch / oil pump)	
• Rated voltage	
- LMV37.400A1, LMV37.420A1	AC 120 V, 50 / 60 Hz
- LMV37.400A2	AC 230 V, 50 / 60 Hz
• Rated current	
- LMV37.400A1, LMV37.400A2	2 A
- LMV37.420A1	1,6 A pilot duty load declaration to UL372
• Power factor	$\text{Cos}\varphi > 0.4$
Connections for pressure switch	
• Rated voltage	
- LMV37.400A1, LMV37.420A1	AC 120 V, 50 / 60 Hz
- LMV37.400A2	AC 230 V, 50 / 60 Hz
• Rated current	1.5 mA
• Power factor	---

4.1.3 Analog output / load output X74 pin 3

Accuracy of output voltage	±1%
----------------------------	-----

4.1.4 Cable lengths

• Mains line AC 120 V / AC 230 V	Max. 100 m (100 pF/m)
• Display, BCI	For installation under the burner hood or in the control panel Max. 3 m (100 pF/m)
• Load controller (LR) X5-03	Max. 20 m (100 pF/m)
• Load controller X64 (24 mA)	Max. 20 m (100 pF/m)
• Safety loop / burner flange (total)	Max. 20 m (100 pF/m)
• External lockout reset button	Max. 20 m (100 pF/m)
• Safety valve (SV)	Max. 20 m (100 pF/m)
• Load output ¹⁾	Max. 10 m (100 pF/m)
• VSD control ¹⁾²⁾	Max. 3 m (100 pF/m)
• Speed input	Max. 3 m (100 pF/m)
• Fuel valve (V1/V2/V3)	Max. 3 m (100 pF/m)
• Pilot valve (PV)	Max. 3 m (100 pF/m)
• Ignition transformer (Z)	Max. 3 m (100 pF/m)
• Other lines	Max. 3 m (100 pF/m)

¹⁾ Do not run the cable together with other cables. If not observed, hum voltage might cause electromagnetic interference

²⁾ Shorter cable length due to closed control loop

Specification as per EN 60730-1

Type of shutdown or interruption of each circuit	
Shutdown with microswitch	1-pole
Mode of operation	Type 2 B

4.1.5 Cross-sectional areas

The cross-sectional areas of the mains power lines (L, N, and PE) and, if required, the safety loop (safety limit thermostat, water shortage, etc.) must be sized for rated currents according to the selected external primary fuse.

The cross-sectional areas of the other cables must be sized in accordance with the internal unit fuse (max. 6.3 AT).

Min. cross-sectional area	0.75 mm ² (single- or multi-core as per VDE 0100)
---------------------------	---

Cable insulation must meet the relevant temperature requirements and environmental conditions.

Fuses used inside the LMV37.4... basic unit	
- F1	6.3 AT DIN EN 60127 2 / 5

4.1.6 Connections of actuators

The ready connected actuator cables must not be extended.

4.2 Signal cable AGV50... from AZL2... → BCI

Signal cable	Color white Unshielded Conductor 4 x 0.141 mm ² With RJ11 plug
Cable length	
- AGV50.100	1 m
- AGV50.300	3 m
Supplier	Recommended: Hütter http://www.huetter.co.at/telefonkabel.htm Order number: on request
Location	Under the burner hood (extra measures required for SKII EN 60730-1)

4.3 Environmental conditions

Storage	DIN EN 60721-3-1
Climatic conditions	Class 1K3
Mechanical conditions	Class 1M2
Temperature range	-20...+60 °C
Humidity	<95 % r.h.
Transport	DIN EN 60721-3-2
Climatic conditions	Class 2K2
Mechanical conditions	Class 2M2
Temperature range	-30...+60 °C
Humidity	<95 % r.h.
Operation	DIN EN 60721-3-3
Climatic conditions	Class 3K3
Mechanical conditions	Class 3M3
Temperature range	-20...+60 °C
Humidity	<95 % r.h.



Caution!
Condensation, formation of ice and ingress of water are not permitted!

4.4 Flame detector

4.4.1 Ionization probe

For continuous operation!

No-load voltage at ION terminal (X10–05 pin 2)	Approx. U_{Mains}
---	----------------------------



Caution!
Protect the ionization probe against electric shock hazard!

Short-circuit current	Max. AC 1 mA
Required detector current	Min. DC 4 μA , flame display approx. 30%
Possible detector current	Max. DC 16...40 μA , flame display approx. 100%
Max. perm. length of detector cable (laid separately)	3 m (wire-ground 100 pF/m)



Warning!
Simultaneous operation of QRA... and ionization probe is not permitted!



Note

The higher the detector cable's capacitance (cable length), the more voltage at the ionization probe, and thus the detector current, drops. Long cable lengths plus very highly resistive flames might necessitate low-capacitance detector cables (e.g. ignition cable). In spite of technical measures taken in the circuitry aimed at compensating potential adverse effects of the ignition spark on the ionization current, it must be made certain that the minimum detector current required is already reached during the ignition phase. If this is not the case, the connections on the primary side of the ignition transformer must be changed and/or the electrodes relocated.

Threshold values when flame is supervised by an ionization probe:

- Start prevention (extraneous light)	Intensity of flame (parameter 954) $\geq 18\%$
- Operation	Intensity of flame (parameter 954) $> 24\%$

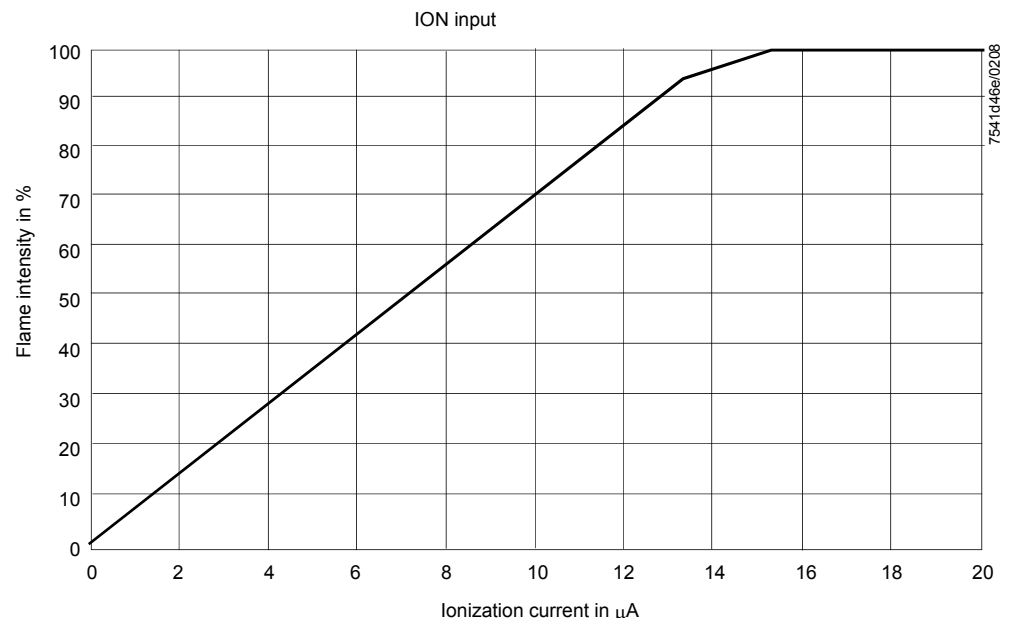
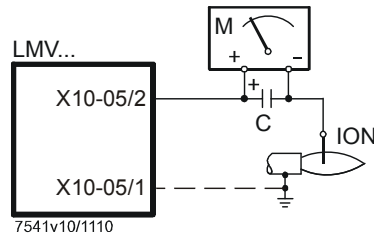

Figure 4: Ionization input at AC 120 V / AC 230 V

Measuring circuit for
detector current
measurement

Ionization probe



Legend

- C Electrolytic capacitor 100...470 μ F; DC 10...25 V
- ION Ionization probe
- M Microammeter R_i max. 5000 Ω

4.4.2 UV flame detectors QRA2 / QRA4 / QRA10



Caution!

If flame detectors QRA2 / QRA4 / QRA10 are used for flame supervision with the LMV37.4..., it must be ensured that the basic unit is permanently connected to power (conforming to EN 298), thus enabling the system to detect flame detector failures during startup and shutdown.

Generally, the system works with QRA flame detectors in intermittent operation. For technical data, refer to Data Sheet N7712 covering UV flame detectors QRA2 / QRA10!

For technical data, refer to Data Sheet N7711 covering UV flame detectors QRA4!

Operating voltage	Max. 350 V peak
Required detector current in operation	Min. 70 μ A
Possible detector current in operation	Max. 600 μ A
Permissible length of flame detector cable - normal cable (laid separately)	Max. 20 m

Measuring circuit for
detector current
measurement

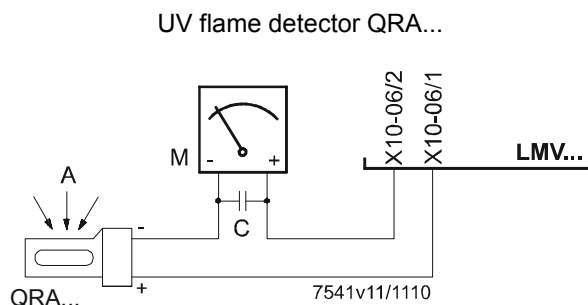

Legend

- A Incidence of light
- C Electrolytic capacitor 100...470 μ F; DC 10...25 V
- M Microammeter R_i max. 5000 Ω



Warning!

- **Input QRA... is not short-circuit-proof!**
Short-circuits of X10-06 pin 2 against earth can destroy the QRA... input
- **Simultaneous operation of QRA... and ionization probe is not permitted!**

Threshold values when flame is supervised by QRA...:

- Start prevention (extraneous light) Intensity of flame (parameter 954) $\geq 18\%$
- Operation Intensity of flame (parameter 954) $> 24\%$

4.4.3 Photoresistive flame detectors QRB...

No-load voltage at QRB... terminal (X10-05 pin 3)	Approx. DC 5 V
Max. perm. length of QRB... detector cable (laid separately)	3 m (wire – wire 100 pF/m)



Note

A detector resistance of $R_F < 500 \Omega$ is identified as a short-circuit and leads to safety shutdown in operation as if the flame had been lost.

For this reason, before considering the use of a highly sensitive photoresistive detector (QRB1B... or QRB3S), it should be checked whether this type of flame detector is indeed required! Increased line capacitance between QRB... connection and mains live wire L has an adverse effect on the sensitivity and increases the risk of damaged flame detectors due to overvoltage. Always run detector cables separately!

Threshold values when flame is supervised by QRB...:	
Start prevention (extraneous light) with R_{QRB}	$< 400 \text{ k}\Omega$ Intensity of flame $\geq 10\%$
Operation with R_{QRB}	$< 230 \text{ k}\Omega$ Intensity of flame $> 16\%$
Short-circuit detection with R_{QRB}	$< 0.5 \text{ k}\Omega$

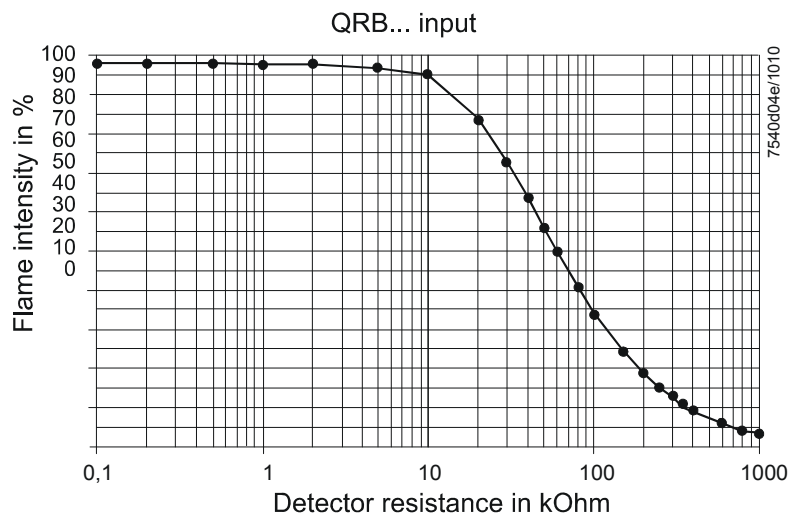

Figure 5: QRB... input at AC 120 V / AC 230 V

A flame detector resistance of $R_F < 500 \Omega$ is identified as a short-circuit and leads to safety shutdown in operation, like in the case of loss of flame.

4.4.4 Blue-flame detectors QRC...

Check the intensity of flame with the AZL2...

For system-specific reasons, the display of maximum flame intensity by the AZL2... is limited to approx. 55 %.



Caution!

Flame detectors QRC... are only suited for AC 230 V operation.

Threshold values when flame is supervised by QRC...:

- Start prevention (extraneous light)	Intensity of flame (parameter 954) $\geq 10\%$
- Operation	Intensity of flame (parameter 954) $> 16\%$

Required detector current (with flame)	Min. 70 μA
Possible detector current (without flame)	Max. 5,5 μA
Permissible detector current with flame	Max. 100 μA

The values given in the table above only apply under the following conditions:

- Mains voltage AC 230 V
- Ambient temperature 23 °C

Start prevention (extraneous light) with IQRC	Ca. 15 μA , display approx. 10 %
---	---

Operation with IQRC	Ca. 25 μA , display approx. 16 %
---------------------	---

Measuring circuit for detector current measurement

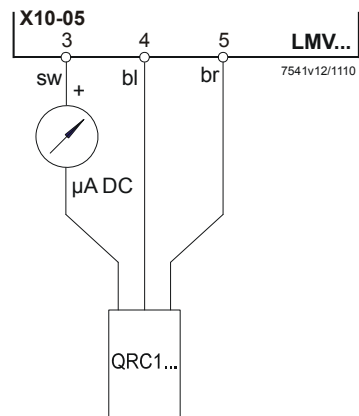

Legend

- $\mu\text{A DC}$ DC-Mikroampèremeter an internal resistance of $R_i = \text{max. } 5 \text{ k}\Omega$
- bl blue
- sw black
- br brown

5 Dimensions

5.1 LMV37.4...

Dimensions in mm

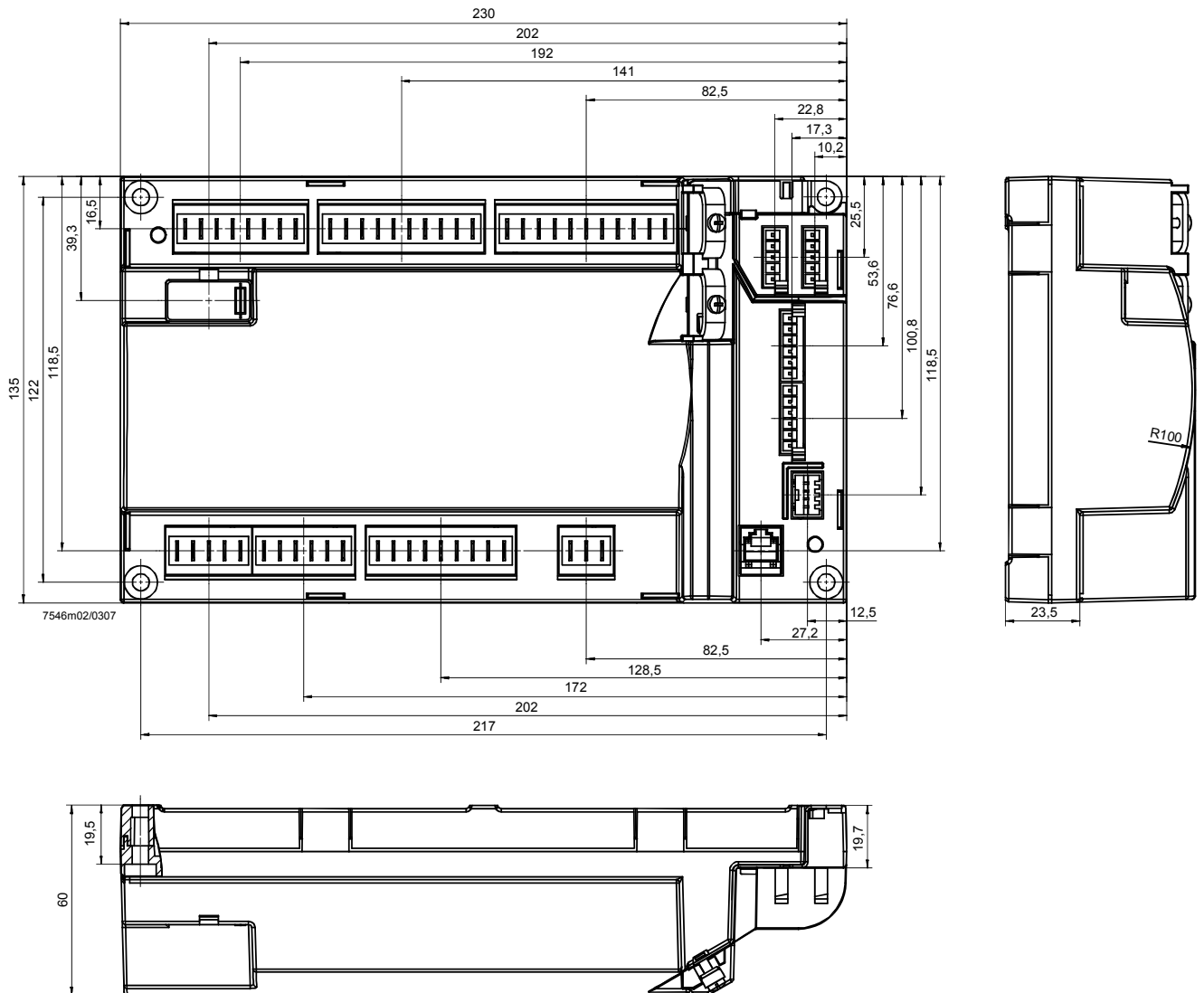

Figure 6: Dimension LMV37.4...

6 Display and diagnostics

Transmission of operating states, fault status messages and detailed service information via:

- BCI communication via integrated RJ11 jack to the AZL2... display and operating unit, or via additional OCI410... interface to ACS410 PC software

Communication / parameterization

AZL2...

The AZL2... offers ease of operation, parameterization and targeted diagnostics via features menu-driven operation. When making diagnostics, the display shows operating states, the type of error and startup meter reading. Passwords protect the different parameter levels of the burner / boiler manufacturer and heating engineer against unauthorized access.

ACS410 PC software

ACS410 PC software enabled a simple operation, comfortable readout of settings and operating states, the parameterization, trend recording and targeted diagnostic of LMV3. Therefore, the separate available OCI410... interface (for BCI communication with LMV3 to the PC) has to be connected to the integrated jack RJ11.

7 Basic unit

7.1 Description of inputs and outputs

This chapter covers the key features of the basic unit's inputs and outputs. For exact use of the inputs and the activation of outputs, refer to chapter *Sequence diagrams*.

Flame signal input and flame detector X10-05 and X10-06

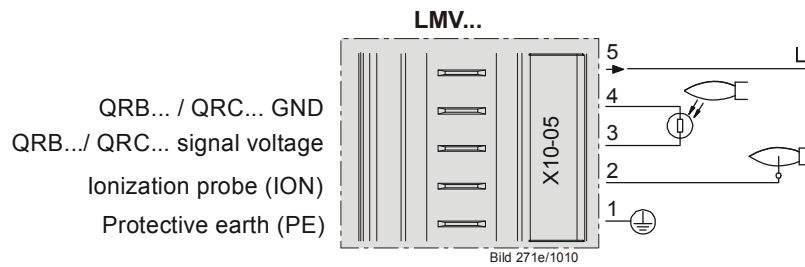

Figure 7: Flame signal input X10-05

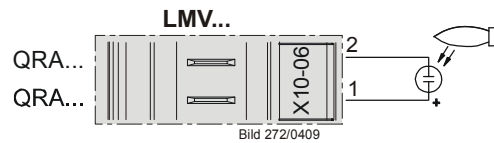

Figure 8: Flame signal input X10-06

Connection choices:

- Ionization probe
- QRA2 / QRA10
- QRA4
- QRB
- QRC

7.2 Flame detectors

- For display of the flame on the AZL2..., the following general conditions apply:
 - Display is subject to various component tolerances, which means that deviations of $\pm 10\%$ can occur
 - Note that, for physical reasons, there is no linear relationship between flame display and detector signal values

The LMV37.4... system can be used with different types of flame detectors. For the correct use of flame detectors, refer to chapter *Sequence diagrams*.

The flame detector used must be correctly parameterized.



Caution!

Only ionization probes are suited for continuous operation!

In the hardware of the LMV37.4..., the flame signals are subdivided into 2 groups (group 0 covering the QRB... and QRC..., and group 1 covering ionization and the QRA...).

The flame detector for gas is selected via parameter 221, that for oil via parameter 261.

No.	Parameter
221	Gas: Active detector flame evaluation 0 = QRB... / QRC... 1 = ION / QRA...
261	Oil: Active detector flame evaluation 0 = QRB... / QRC... 1 = ION / QRA...

7.2.1 Loss of flame

In the event of loss of flame, the unit initiates safety shutdown, followed by a restart, if required. A repetition counter can be used to select the number of flame losses after which the unit shall initiate lockout (refer to chapter *Repetition counter*).

Error code	Diagnostic code	Meaning for the LMV37.4... system
7	0	Loss of flame

No.	Parameter
186	Software drop out delay time of flame signal (100 ms) Index 0 = QRB... / QRC... (0 = inactive, >1) Index 1 = ION / QRA... (0 = inactive, >3 - only 200 ms-steps)
194	Repetition limit no flame at the end of safety time (TSA) 1 = no repetition 2...4 = 1...3 repetitions Recharging time: Entering into operation
240	Repetition limit loss of flame 1 = no repetition 2 = 1 repetition
280	Repetition limit loss of flame 1 = no repetition 2 = 1 repetition



Caution!

The response time of the flame detector leads to an extension of the second safety time 2 (TSA2)! This must be taken into consideration when designing the burner!

7.2.2 Extraneous light

Extraneous light in standby mode (phase 12) leads to start prevention, followed by a restart. Extraneous light during the prepurge phase results in immediate lockout. If extraneous light occurs during the shutdown phase, the system switches to the safety phase.

One repetition is permitted. This means that if the error occurs again the next time the system is shut down, the unit will initiate lockout.

Error code	Diagnostic code	Meaning for the LMV37.4... system
4	0	Extraneous light during startup
	1	Extraneous light during shutdown
	2	Extraneous light during startup – start prevention

7.2.3 No flame at the end of safety time 1 (TSA1)

If no flame is established by the end of the first safety time, the unit initiates lockout.

Error code	Diagnostic code	Meaning for the LMV37.4... system
2	1	No flame at the end of safety time 1 (TSA1)
	2	No flame at the end of safety time 2 (TSA2)

7.2.4 Flame intensity

The flame's intensity can be displayed.
It is standardized from 0 to 100%.

No.	Parameter
954	Intensity of flame



Note

Also refer to chapter *Intensity of flame during curve settings*.

7.2.5 Supervision of flame detector

Error code	Diagnostic code	Meaning for the LMV37.4... system
93	3	Short-circuit of flame detector

At the QRB... / QRC... flame detector's input, the LMV37.4... checks the detector for short-circuits in operation.

7.3 Digital inputs

7.3.1 Safety loop X3-04 pin 1 and 2

Input for connection of the safety loop. When any of the series-connected contacts included in the loop opens, power supply to the fuel valves, the fan and the ignition equipment is instantly cut.

The safety loop includes the following components:

- External burner switch (ON / OFF)
- Safety limiter / safety pressure limiter (SL / SPL)
- External control thermostat and / or pressurestat, if required
- Water shortage switch



Note

Pressure switch-max (Pmax) when using POC via X5-02.

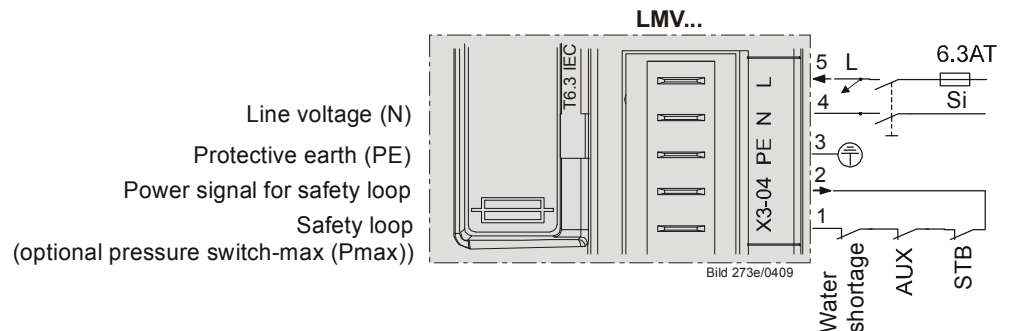

Figure 9: Safety loop X3-04

For diagnostic purposes, the contacts of the components included in the safety loop and the burner flange contact are combined for delivering the safety loop signal. If there is no such signal, the system initiates safety shutdown in any event.

If, with *Load controller ON*, there is no signal from the safety loop (start prevention), error code 22 is translated to text display **OFF S** (S = safety loop) and the numerical value appears in the error history.

Error code	Diagnostic code	Meaning for the LMV37.4... system
22 OFF S	0	Safety loop/burner flange Open

For the input, a repetition counter can be parameterized. Here, it is possible to set the number of errors permitted until lockout occurs (refer to chapter *Repetition counter*).

No.	Parameter
215	Repetition limit safety loop 1 = no repetition 2...15 = 1...14 number of repetitions 16 = constant repetition



Attention!

In the safety loop, temporarily (<1 s) switching contacts must not be wired (switch or other)!

7.3.2 (Burner flange) X3–03, pin 1 and 2

End switch burner flange (component of safety loop).

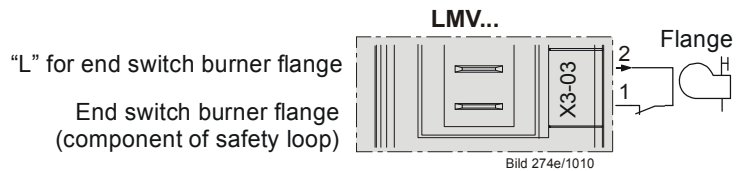

Figure 10: Burner flange X3-03

For error diagnostics and parameters, refer to chapter *Safety loop*.

7.3.3 Input for external controller (ON / OFF) X5–03, pin 1

When the external control loop is closed, the internal input message «Heat request» is generated.

A heat request exists when the external controller signal is pending and, depending on the configuration, a load controller calls for heat (refer to chapter *Connection of load controllers*).

When there are no more requests for heat, the burner shuts down. The fuel valves are closed, either immediately when the timer has elapsed, or when the low-fire position is reached, depending on the parameter settings (refer to chapter *End of operating position*).



Note

Burner startup takes place only when this contact is closed.

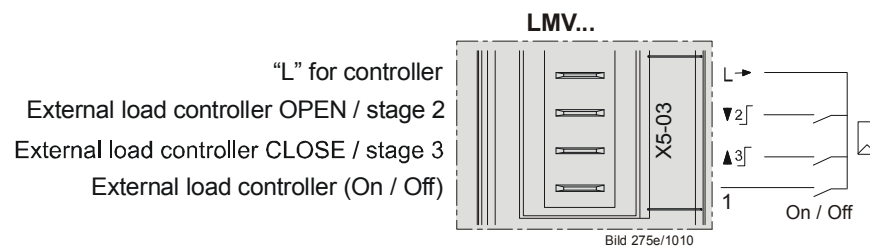

Figure 11: Inputs for external load controller ON / OFF X5-03

7.3.4 Inputs X5-03 pin 2 and 3 (Open / Close or stage 2 / stage 3)

Inputs for connection of an external controller with contact outputs (refer to chapter *External load controller via contacts X5-03, pin 2 and 3*).

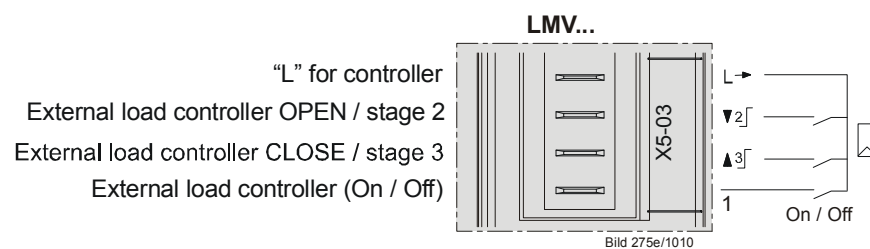

Figure 12: Inputs external load controller Open / Close X5-03



Note!

When the *Switching back to pilot* function (parameter 191) is used, the load controller contacts are not available (refer to chapter *Switching back to pilot*).

7.3.5 Air pressure switch (APS) X3-02

Input for connection of an air pressure switch. Air pressure is anticipated when the fan is switched on. If there is no air pressure signal, the system initiates lockout. The air pressure switch must have an NO contact.

If no air pressure switch is required (e.g. when firing on oil), a wire link to the fan output must be fitted (between X3-02, pin 1, and X3-05, pin 1).



Caution!

The OEM must check to see whether the burner can be operated without air pressure switch. This may necessitate a special approval, depending on the type of application.

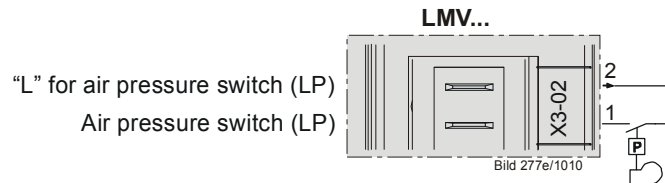

Figure 13: Air pressure switch (APS) X3-02

No.	Parameter
235	Air pressure switch 1 = active 2 = active, except phase 60...66 (pneumatic operation only)

Error code	Diagnostic code	Meaning for the LMV37.4... system
3	0	Air pressure off
	1	Air pressure on
	4	Air pressure on – start prevention

For the input, a repetition counter can be parameterized. Here, it is possible to set the number of errors that are permitted until lockout occurs (refer to subsection *Repetition counter*).

No.	Parameter
196	Repetition limit air pressure failure 1 = no repetition 2 = 1 repetition

7.3.6 Gas pressure switch valve proving (P LT) – or heavy oil direct start X9-04

Input for connection of *Pressure switch valve proving* (P LT) X9-04. The input is active only when operating on gas and when valve proving is activated (refer to chapter *Program sequence*).

No.	Parameter
241	Gas: Execution valve proving 0 = no valve proving 1 = valve proving on startup 2 = valve proving on shutdown 3 = valve proving on startup and shutdown

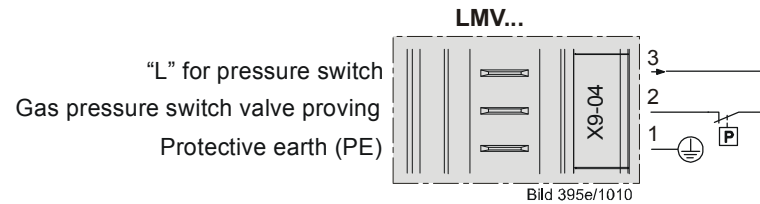

Figure 14: Pressure switch valve proving gas (P LT) X9-04

Pressure switch valve proving (P LT)

Input for connection of valve proving with a specific pressure switch. The input is active only when firing on gas and when valve proving is activated.

Error code	Diagnostic code	Meaning for the LMV37.4... system
12	0	Fuel valve 1 (V1) leaking
	1	Fuel valve 2 (V2) leaking



Note

When using configuration *Valve proving via gas pressure switch-min* (Pmin), it is not possible to use the input for *Start release gas*.

Heavy oil direct start

When firing on heavy oil, input X9-04 is used for the *heavy oil direct start* signal. Parameter 286 can be used to define the time of the evaluation; parameter 287 to define the maximum waiting time for heavy oil circulation.

No.	Parameter
286	Oil: Evaluation of heavy oil direct start 0 = only start signal in phase 38 1 = evaluation in phase 38...62
287	Oil: Maximum time heavy oil start signal

Error code	Diagnostic code	Meaning for the LMV37.4... system
23	2	Heavy oil direct start

For the input, a repetition counter can be parameterized. Here, it is possible to set the number of errors that are permitted until lockout occurs (refer to subsection *Repetition counter*).

No.	Parameter
195	Repetition limit heavy oil direct start 1 = no repetition 2...15 = 1...14 number of repetitions 16 = constant repetition

7.3.7 Gas / oil pressure switch-min (Pmin), start release gas X5-01

Input for connection of a pressure switch-min for gas or oil: If the plant does not require a pressure switch-min, a wire link must be fitted between pin 2 and 3.

Gas pressure switch-min

In all types of gas trains, minimum gas pressure is expected from phase 22. If no gas pressure is detected when the maximum time (parameter 214) has elapsed, the gas shortage program is started (refer to chapter *Gas shortage program*).

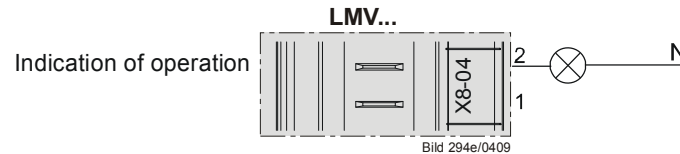

Figure 15: Gas pressure switch-min (Pmin) X5-01



Caution!

The OEM must check to see whether the burner can be operated without pressure switch-min. This may necessitate a special approval, depending on the type of application.

No.	Parameter
214	Max. time to start release

During the safety times (TSA1/TSA2), the signal received from pressure switch-min is only assessed after a certain period of time in order to ignore the pressure shocks that occur the moment the valves open. The time to elapse for signal assessment can be parameterized.

No.	Parameter
229	Gas: Time to respond to pressure faults within safety time 1 (TSA1) and safety time 2 (TSA2)

If there is no gas pressure, at least safety shutdown is initiated.

Error code	Diagnostic code	Meaning for the LMV37.4... system
20	0	Pressure switch-min (Pmin) No min. gas / oil pressure
20	1	Gas shortage start prevention

For the input, a repetition counter can be parameterized. It can be used to set the number of errors permitted until lockout occurs. The counter also impacts the gas shortage program (refer to chapter *Repetition counter*).

No.	Parameter
223	Repetition limit gas pressure switch-min 1 = no repetition 2...15 = 1...14 number of repetitions 16 = constant repetition

Start release gas

If, at the same time, the input is used as a start release input (e.g. for an air supply damper), it can be connected in series with the pressure switch.

When selecting *Valve proving via pressure switch-min* (parameter 236), function *Start release gas* is not supported.

Oil pressure switch-min

In all types of oil train, the minimum oil pressure is expected from phase 38. If no oil pressure is detected when the maximum time (parameter 217) has elapsed or if, subsequently, the oil pressure drops, the system initiates lockout.

No.	Parameter
217	Maximum waiting time for detecting a detector or pressure switch signal (e.g. home run, preignition)

Error code	Diagnostic code	Meaning for the LMV37.4... system
20	0	Pressure switch-min (Pmin) No min. gas / oil pressure
20	1	Gas shortage start prevention

During the safety times (TSA1/TSA2), the signal from pressure switch-min is only assessed after a certain period of time in order to ignore the pressure shocks that occur the moment the valves open. The time to elapse for signal assessment can be parameterized.

No.	Parameter
269	Oil: Time to respond to pressure faults within safety time 1 (TSA1) and safety time 2 (TSA2)

7.3.8 Setting the time for making the pressure switch test

For oil pressure switch-min, the point in time after which the evaluation is made can be set via parameter 276 (active from phase 38 or from the safety time (TSA)).

No.	Parameter
276	Oil: Pressure switch-min-input 0 = inactive 1 = active from phase 38 2 = active from the safety time (TSA)

7.3.9 Gas / oil pressure switch-max (Pmax) / or POC contact, start release oil X5-02

Input for connection of a pressure switch-max for gas or oil: The pressure switch must have an NC contact, which means that the contact opens when the adjusted maximum pressure is exceeded. If the plant does not require a pressure switch-max, a wire link must be fitted between pin 2 and 3.



Caution!

The OEM must check to see whether the burner can be operated without pressure switch-max. This may necessitate a special approval, depending on the type of application.

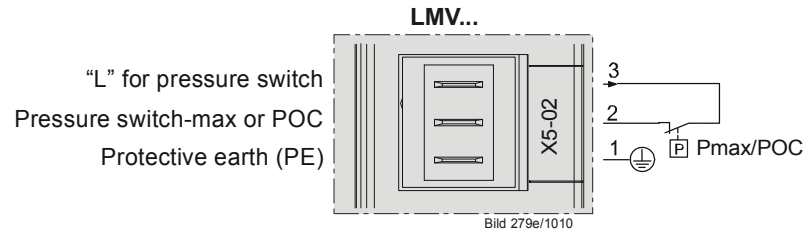

Figure 16: Gas / oil pressure switch-max (Pmax) or POC X5-02

The connection facility can also be used as POC (proof of closure) (refer to chapter *Sequence diagrams*).

No.	Parameter
237	Gas: Pressure switch-max/POC input 0 = inactive 1 = pressure switch-max 2 = POC 3 = Pressure switch valve proving



Note

If the input is used for POC or for pressure switch, pressure switch-max can be included in the safety loop. In that case, pressure switch-max must not be fitted between the valves, but downstream from them.

Gas pressure switch-max

In all types of gas trains, the maximum gas pressure is monitored from phase 40. If the maximum gas pressure is exceeded, the system initiates lockout.

Error code	Diagnostic code	Meaning for the LMV37.4... system
14	0	POC open
	1	POC close
21	0	Pressure switch-max (Pmax): Max. gas pressure exceeded POC: POC open (software version ≤V02.00)
	1	POC close (software version ≤V02.00)

During the safety times (TSA1 / TSA2), the signal from pressure switch-max is only assessed after a certain period time has elapsed in order to ignore the pressure shocks that occur the moment the valves open.

No.	Parameter
229	Gas: Time to respond to pressure faults within safety time 1 (TSA1) and safety time 2 (TSA2)

Oil pressure switch-max

In all types of oil trains, the maximum oil pressure is monitored from phase 22. If the maximum oil pressure is exceeded after the maximum time (parameter 214) has elapsed, or during the subsequent phases, the system initiates lockout.

No.	Parameter
214	Max. time start release

Error code	Diagnostic code	Meaning for the LMV37.4... system
14	0	POC open
	1	POC close
21	0	Pressure switch-max (Pmax): Max. oil pressure exceeded POC: POC open (software version \leq V02.00)
	1	POC: close (software version \leq V02.00)

During the safety times (TSA1 / TSA2), the signal from pressure switch-max is only assessed after a certain period of time has elapsed in order to ignore the pressure shocks that occur the moment the valves open.

No.	Parameter
269	Oil: Time to respond to pressure faults within safety time 1 (TSA1) and safety time 2 (TSA2)

The connection facility can also be used for POC (proof of closure) (refer to chapter *Sequence diagrams*).

No.	Parameter
277	Oil: Pressure switch-max-/POC input 0 = inactive 1 = pressure switch-max 2 = POC



Note

If the input is used for POC, pressure switch-max can be included in the safety loop. In that case, pressure switch-max must not be installed between the valves, but always downstream from them.

Start release oil

If the input is simultaneously used as a start release input, e.g. for an air supply damper, the latter can be connected in series with the pressure switch.

Parameters with POC function cannot be used as start release input.

7.3.10 Reset X8-04, pin 1

Input for connection of a reset button. The basic unit can be reset or manually locked via this input (refer to chapter *Reset / manual locking*).



Figure 17: Reset X8-04

7.4 Digital outputs

Safety-related outputs, type SI

Using a contact feedback network (CFN), these contacts are read back by the microcomputers and checked for their correct positions.

Non-safety-related outputs, type No-SI

These outputs are not monitored by the contact feedback network (CFN) and, for this reason, can only be used for non-safety-related actuators, or actuators made safe in some other form (e.g. alarm).

7.4.1 Output alarm type No-SI – X3-05, pin 2

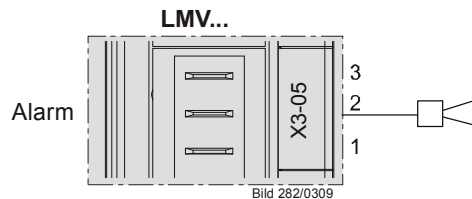

Figure 18: Output alarm X3-05

Output for connection of an alarm lamp or horn.

The output is activated when the unit is in the lockout position (phase 00). This output can also be used to indicate start prevention.

7.4.2 Fan motor contactor type SI – X3-05, pin 1

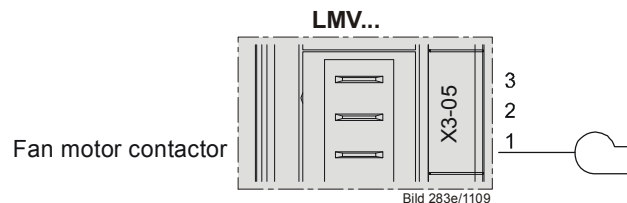

Figure 19: Fan motor contactor X3-05

Output for control of a fan power contactor (200 VA). In accordance with the sequence diagrams, the fan is on in phase 22 (refer to chapter *Sequence diagrams*).

7.4.3 Fan continuous purging X3-05, pin 3

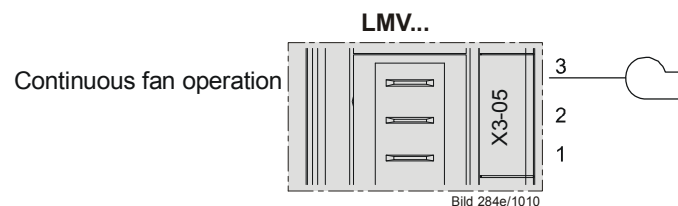

Figure 20: Continuous fan operation X3-05

If continuous purging is required, the fan motor contactor must be connected to *Continuous fan operation* – X3-05, pin 3. This terminal is tapped behind the unit fuse and the safety loop (refer to chapter *Continuous fan*).

7.4.4 Output ignition (Z) type SI (IGNITION) X4-02

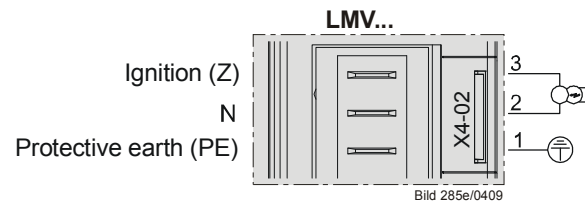

Figure 21: Output ignition (Z) X4-02

Output for the connection of ignition transformers or electronic ignition modules.

Gas

When firing on gas, ignition is switched on in phase 38 just before reaching safety time 1 (TSA1).

The preignition time in phase 38 can be parameterized.

No.	Parameter
226	Gas: Preignition time

Oil

When firing on oil, there is a choice of short and long preignition (same as with gas).

No.	Parameter
281	Oil: Point in time oil is ignited 0 = short preignition (Ph38) 1 = long preignition (with fan) (Ph22)

When using long preignition, ignition is switched on in phase 22, together with the fan.

In the case of short preignition, the preignition time can be parameterized.

No.	Parameter
266	Oil: Preignition time

7.4.5 Outputs fuel valves type SI (V1...V3 / PV) X8-02, X7-01, X7-02

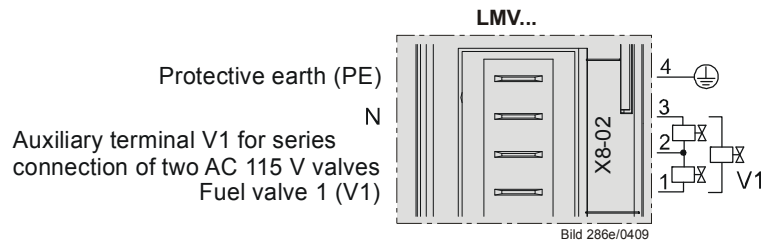

Figure 22: Output fuel valve (V1) X8-02

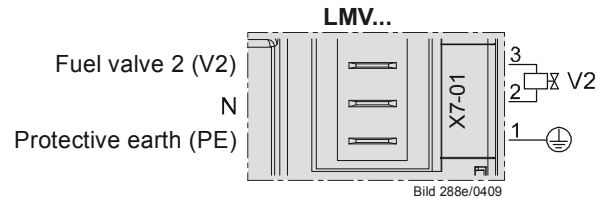

Figure 23: Output fuel valve (V2) X7-01

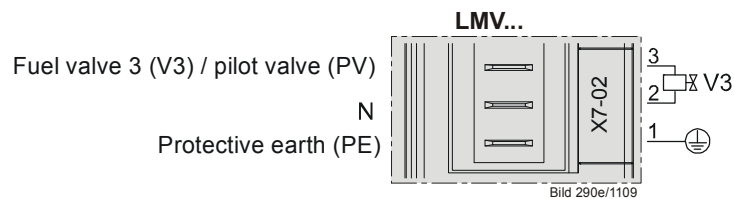

Figure 24: Output fuel valve (V3) / pilot valve (PV) X7-02

Outputs for connection of the gas or oil valves, depending on the selected type of fuel train (refer to chapter *Sequence diagrams*).

7.4.6 Output safety valve (SV) type SI X6-03

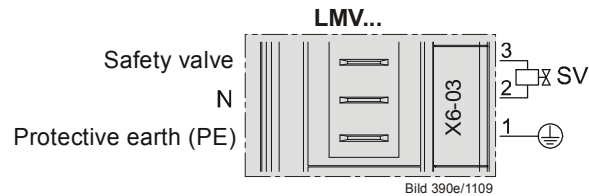

Figure 25: Output safety valve (SV) X6-03

Output for connection of an oil valve or safety valve for liquefied gas. The output is connected parallel to the output for the fan.

7.4.7 Output for indication of operation X8-04, pin 2

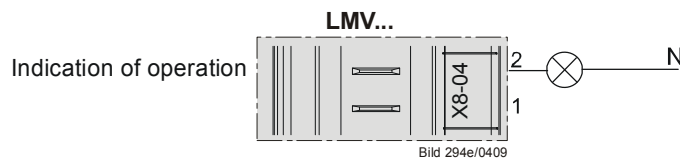

Figure 26: Output for indication of operation X8-04

Output for connection of indication of operation.



Caution!
The output is connected parallel to the fuel valve (V1).

7.5 Program sequence

The program sequence is shown in the form of sequence diagrams (refer to chapter *Fuel trains*). Using a number of parameters, the program sequence can be adapted to the respective application.

7.5.1 Time parameters

Using a number of time parameters, the time characteristics of the different types of fuel trains can be matched to the requirements of the respective application.

No.	Parameter
192	<i>Switching back to pilot</i> minimum time
193	<i>Switching back to pilot</i> maximum time
211	Fan ramp up time
212	Max. time to low-fire
213	Waiting time home run
214	Max. time to start release
217	Max. waiting time for detecting a detector or pressure switch signal (e.g. home run, preignition)
225	Gas: Prepurge time
226	Gas: Preignition time
227	Gas: Safety time 1 (TSA1)
229	Gas: Time to respond to pressure faults within safety time 1 (TSA1) and safety time 2 (TSA2)
230	Gas: Interval 1
231	Gas: Safety time 2 (TSA2)
232	Gas: Interval 2
233	Gas: Afterburn time
234	Gas: Postpurge time (no extraneous light test)
242	Gas: Valve proving evacuation time
243	Gas: Valve proving time test atmospheric pressure
244	Gas: Valve proving filling time
245	Gas: Valve proving time test gas pressure
246	Gas: Gas shortage waiting time
248	Gas: Postpurge time (t3) (interruption if load controller (LR) ON)
265	Oil: Prepurge time
266	Oil: Preignition time
267	Oil: Safety time 1 (TSA1)
269	Oil: Time to respond to pressure faults within safety time 1 (TSA1) and safety time 2 (TSA2)
270	Oil: Interval 1
271	Oil: Safety time 2 (TSA2)
272	Oil: Interval 2
273	Oil: Afterburn time
274	Oil: Postpurge time (no extraneous light test)
284	Oil: Postpurge time (t3) (interruption if load controller (LR) ON)
287	Oil: Maximum time heavy oil start signal



Caution!

The OEM or the heating engineer must make certain that the times conform to the standards covering the respective type of plant.

7.5.2 Valve proving

Valve proving is only active when firing on gas. Valve proving designed to detect leaking gas valves and, if necessary, to prevent the valves from opening or ignition from being switched on. Lockout is initiated, if required.

When performing valve proving, the gas valve on the burner side is opened first to bring the test space to atmospheric pressure. After closing the valve, the pressure in the test space must not exceed a certain level. Then, the gas valve on the mains side is opened to fill the gas pipe. After closing, the gas pressure must not fall below a certain level.

Valve proving can be parameterized to take place on startup, shutdown, or on both. The type of valve proving can be selected via parameter 236.

Recommendation:

Perform valve proving on shutdown.

No.	Parameter
236	Gas: Pressure switch-min input 0 = inactive 1 = pressure switch-min (upstream of fuel valve 1 (V1)) 2 = valve proving via pressure switch-min (between fuel valve 1 (V1) and fuel valve 2 (V2))
241	Gas: Execution valve proving 0 = no valve proving 1 = valve proving on startup 2 = valve proving on shutdown 3 = valve proving on startup and shutdown
242	Gas: Valve proving evacuation time
243	Gas: Valve proving time atmospheric pressure
244	Gas: Valve proving filling time
245	Gas: Valve proving time gas pressure



Caution!

If valve proving is parameterized to take place «on startup and shutdown», the gas valves must run through additional switching cycles. As a result, strain on the gas valves (wear) increases.



Caution!

The OEM must set the evacuation, filling and test times for atmospheric or mains pressure on every plant in compliance with the requirements of EN 1643.

It must be ensured that the 2 test times are correctly set. It is to be checked whether the gas required for the test may be fed into the combustion chamber (on the relevant application). The test times are safety-related. After a reset and in the case of aborted or prevented valve proving, the unit performs valve proving on the next startup (only when valve proving is activated). Prepurging with valve proving is active during the startup phase, even if it was deactivated.

Examples of aborted valve proving:

When the safety loop or the start prevention input for gas (containing Pmin) opens during valve proving.

Valve proving – calculation of leakage rate

$$t_{\text{Test}} = \frac{(P_G - P_W) \cdot V \cdot 3600}{P_{\text{atm}} \cdot Q_{\text{Leck}}}$$

QLeck	in l/h	Leakage rate in liters per hour
PG	in mbar	Overpressure between the valves at the beginning of the test phase
PW	in mbar	Overpressure set on the pressure switch (normally 50% of the gas inlet pressure)
Patm	in mbar	Absolute air pressure (1013 mbar normal pressure)
V	in l	Volume between the valves (test volume) including valve volume and pilot pipe, if present (Gp1 mod)
tTest	in s	Test time

7.5.2.1. Valve proving with separate pressure switch (P LT) X9-04

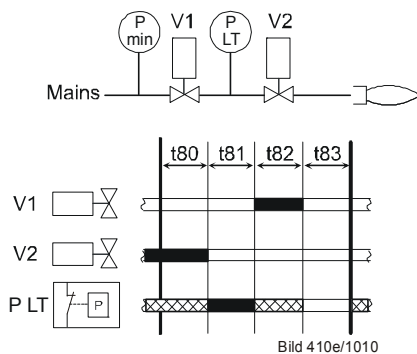

Figure 1: Valve proving with separate pressure switch (P LT)

Step 1: t80 – evacuation of test space.

Gas valve on the burner side is opened to bring the test space to atmospheric pressure.

Step 2: t81 – atmospheric pressure test.

When the gas valve has closed, the gas pressure in the test space must not exceed a certain level.

Step 3: t82 – filling of test space.

Gas valve on the mains side opens to fill the test space.

Step 4: t83 – gas pressure test.

When the gas valve has closed, the gas pressure in the test space must not drop below a certain level.

Legend

t80	Evacuation of test space (parameter 242)
t81	Atmospheric pressure test (parameter 243)
t82	Filling of test space (parameter 244)
t83	Gas pressure test (parameter 245)
V...	Fuel valve
P LT	Pressure switch – valve proving
Pmin	Pressure switch-min
	Input/output signal 1 (ON)
	Input/output signal 0 (OFF)
	Input permissible signal 1 (ON) or 0 (OFF)

7.5.2.2. Valve proving via gas pressure switch-min X5-01

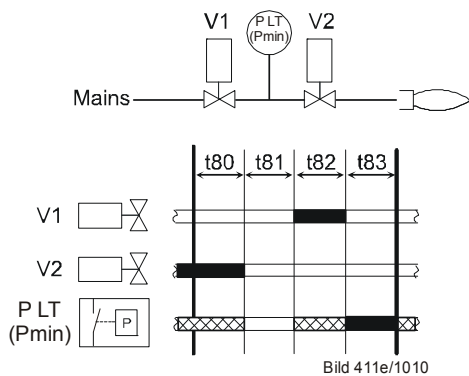

Figure 2: Valve proving via gas pressure switch-min

Step 1: t80 – evacuation of test space.

Gas valve on the burner side is opened to bring the test space to atmospheric pressure.

Step 2: t81 – atmospheric pressure test.

When the gas has closed, the gas pressure in the test space must not exceed a certain level.



Step 3: t82 – filling of test space.

Gas valve on the mains side opens to fill the test space.

Step 4: t83 – gas pressure test.

When the gas valve has closed, the gas pressure in the test space must not drop below a certain level.

Legend

t80	Evacuation of test space (parameter 242)
t81	Atmospheric pressure test (parameter 243)
t82	Filling of test space (parameter 244)
t83	Gas pressure test (parameter 245)
V...	Fuel valve
Pmin	Pressure switch-min
P LT	Pressure switch – valve proving
	Input/output signal 1 (ON)
	Input/output signal 0 (OFF)
	Input permissible signal 1 (ON) or 0 (OFF)

When making the valve proving test via gas pressure switch-min, the impact on the program sequence is as follows (see *Sequence diagram G*):

a) Valve proving on startup

In place of sampling gas pressure switch-min (gas shortage test) in phase 22, it is sampled during the time valve proving is performed at the end of the filling time.

b) Valve proving on shutdown/deactivated

Gas pressure switch-min is sampled at the end of preignition. For that purpose, a new phase 39 (Test *Pmin*) is introduced and evaluation of gas shortage is made at the end of the phase (duration of phase = filling time). In practice, this represents an *extension* of preignition by the filling time, if valve proving via gas pressure switch-min was selected.

The valve proving test can only be made via gas pressure switch-min, which must be fitted between the valves. This has an impact on the control sequence (refer to chapter *Sequence diagrams*). Valve proving is still activated via parameter 241.

7.5.2.3. Lockout phase (phase 00)

The relays of the fuel valves and the safety relay (fan) are deenergized, the alarm relay is energized and lockout takes place. This means that phase 00 can only be quit via a manual reset. The time of phase 00 is unlimited.

7.5.2.4. Safety phase (phase 01)

The safety phase is an intermediate phase which is completed prior to triggering lockout. The relays of the fuel valves and the safety relay (fan) are deenergized, but lockout does not yet take place. The alarm relay is not yet activated. If possible or permitted, safety checks or repetition counter checks are made whose results decide on the transition to *Lockout phase* or *Standby*. The duration of the safety phase is dynamic (depending on the extent of testing), the maximum time being 30 seconds. This process is aimed primarily at avoiding unwanted lockouts, e.g. resulting from EMC problems.

7.5.3 Special functions during the program sequence

7.5.3.1 Reset / manual lockout

The system can be manually locked by simultaneously pressing the **Info** button and **any other button** on the AZL2... This function enables the operator to lock the system from any of the operating levels or, in other words, to trigger non-volatile lockout. Due to the system's structure, this does not represent an *Emergency OFF* function.

When making a reset, the following actions are carried out:

- Alarm relay and fault display are switched off
- The lockout position is canceled
- The unit makes a reset and then changes to standby

The system can be reset in 3 different ways:

1. Resetting on the AZL2... display and operating unit

If the unit is in the lockout position, a reset can be made by pressing the **Info** button for 1...3 seconds. The function is available only when the unit is in the lockout position. Longer or shorter pushes on the button do not produce a reset so that the system maintains the lockout position.

Error code	Diagnostic code	Meaning for the LMV37.4... system
167	2	Manual lockout by the AZL2...

2. Resetting by pressing the button by the *Reset* connection terminal on the LMV37.4... basic unit (X8-04, pin 1)

If the unit is in the lockout position, a reset can be made by pressing the button for 1...3 seconds. Longer or shorter pushes on the button are ignored so that the system maintains the lockout position.

If the unit is **not** in the lockout position and the reset button is pressed for 1...6 seconds, a change to the lockout position takes place.

If this response is not desirable, it is possible to tap the supply for the reset button from the alarm output, thus achieving the same response as described above under 1.

Error code	Diagnostic code	Meaning for the LMV37.4... system
167	1	Manual lockout by contact

Without manual lockout

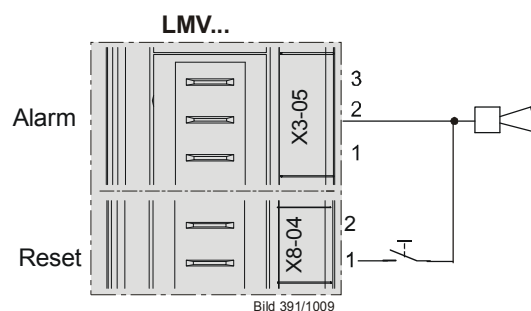

Figure 2: Without manual lockout

With manual lockout

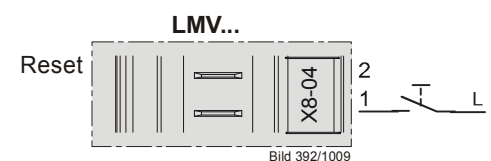

Figure 2: With manual lockout

3. Resetting via the PC software

Refer to the documentation covering the PC software (J7352).

Error code	Diagnostic code	Meaning for the LMV37.4... system
167	3	Manual lockout by PC software

7.5.3.2. Alarm upon start prevention

If start prevention occurs, it is shown on the display of the AZL2...

Start prevention takes place only when a heat request is delivered **and** when one of the startup criteria is not fulfilled.

The time to elapse from start prevention to display on the AZL2... is set to a fixed value of 5 seconds.

In addition, it is possible to indicate start preventions via the alarm output. This function can be activated per parameter.

No.	Parameter
210	Alarm in the event of start prevention 0 = deactivated 1 = activated

If «Alarm in the event of start prevention» is activated via the alarm relay, start prevention and lockout can only be distinguished via the display on the AZL2... Start preventions are displayed as **Err:**, lockouts as **Loc:**.



Note

If reset contact X8-04, pin 1, is activated in the event of start prevention, the unit is manually locked. The time from occurrence of start prevention to indication by the alarm contact equals the time to the display on the AZL2...

7.5.3.3. Possible start preventions

On the normal display, error code 201 is translated to text display **OFF UPr** (UPr = unprogrammiert = not programmed); the numerical value appears in the error history.

Error code	Diagnostic code	Meaning for the LMV37.4... system
201 OFF UPr	1	No operating mode selected
	2...3	No fuel train defined
	4...7	No curve defined
	8...15	Standardized speed undefined
	16...31	Backup / restore was not possible
		Other start preventions:
3	4	Air pressure on – start prevention
4	2	Extraneous light during startup – start prevention
14	64	POC open – prevention of startup
21	64	POC open – prevention of startup (software version ≤V02.00)
22 OFF S	0	Safety loop / burner flange open
83	#	Speed error VSD
97	#	Error relay supervision
	0	Safety relay contacts have welded or external power supply fed to safety relay

No.	Parameter
642	Standardized speed Index 0 = speed 1 Index 1 = speed 2 (internal supervision)
935	Absolute speed
936	Standardized speed

7.5.3.4. Repetition counter

Repetition counters are available for different types of errors. They are used to set the number of errors permitted until lockout occurs. The last error initiates lockout. When setting the number of errors to **3**, for example, a repetition (restart) takes place after the first 3 errors, and after the third error, the system initiates lockout.



Note
Setting 16 means an infinite number of repetitions = no lockout.

Functions with adjustable repetition counter

No.	Parameter
194	<p>Repetition limit no flame at the end of safety time (TSA) 1 = no repetition 2...4 = 1...3 repetitions</p> <p>Recharging time: Entering into operation</p>
195	<p>Repetition limit heavy oil direct start 1 = no repetition 2...15 = 1...14 number of repetitions 16 = constant repetition</p> <p>Recharging time: End of <i>Shutdown</i> phase</p>
196	<p>Repetition limit air pressure failure 1 = no repetition 2 = 1 repetition</p> <p>Recharging time: End of <i>Shutdown</i> phase / 24 hours continuous operation</p>
215	<p>Repetition limit safety loop 1 = no repetition 2...15 = 1...14 number of repetitions 16 = constant repetition</p> <p>Recharging time: Every 24 hours</p>
223	<p>Repetition limit pressure switch-min gas 1 = no repetition 2...15 = 1...14 number of repetitions 16 = constant repetition</p> <p>Recharging time: After the <i>Operation</i> phase</p>
240 280	<p>Repetition limit loss of flame 1 = no repetition 2 = 1 repetition</p> <p>Recharging time: After the <i>Operation</i> phase</p> <p>Parameter assignment: 240 Gas / fuel 0 280 Oil / fuel 0</p>

Error code	Diagnostic code	Meaning for the LMV37.4... system
2	1	No flame at the end of safety time (TSA1)
3	0	Air pressure
7	0	Loss of flame
20	0	Pressure switch-min (Pmin) No min. gas / oil pressure
22 OFF S	0	Safety loop / burner flange open
23	2	Heavy oil direct start

If the adjustable repetition counter limits are changed, the actual counter is recharged only when the associated recharging time is reached: After power-on or after a reset.



Note

If immediate recharging shall be enforced, the basic unit can be manually locked and then reset.

Functions with fixed repetition counters

These counters cannot be set.

Meaning	Settings	
	Unit	Basic setting
Number of repetitions in the event of error: - Speed standardization VSD - Speed error - Referencing error actuator - Positioning error actuator Recharging time: - End of <i>Shutdown</i> phase	---	3
Number of repetitions in the event of error: - Relay - Relay control Recharging time: - End of <i>Operation</i> phase	---	2
Number of repetitions in the event of internal errors Recharging time: - After 24 hours of operation	---	5

Error code	Diagnostic code	Meaning
82	#	Error during speed standardization of the VSD
83	#	Speed error VSD
85	#	Referencing error of an actuator
86	#	Error fuel actuator
87	#	Error air actuator
95...98	#	Error relay supervision
99...100	#	Internal error relay control

7.5.3.5. Start without prepurging (as per EN 676)

When using valve proving and 2 fuel valves of class A, prepurging is not required (conforming to EN 676).

Prepurging can be deactivated per parameter.

No.	Parameter
222	Gas: Prepurging 0 = deactivated 1 = activated

When prepurging is activated, it is performed in accordance with the adjusted prepurge time.

If not activated, it is nevertheless performed if one or several of the following conditions apply:

- Alterable lockout position
- After an off time of >24 hours
- In the event of a power failure (power-on)
- In the event of shutdown due to an interruption of gas supply (safety shutdown)

No.	Parameter
225	Gas: Prepurge time

7.5.3.6. Gas shortage program

Valve proving via gas pressure switch-min (parameter 236 = 2)

As gas pressure switch-min is located between the valves, the gas shortage test cannot be made in phase 22. Instead, when performing valve proving on startup, the gas shortage test is performed at the end of the filling time (end of phase 82). Without valve proving on startup, the gas shortage test is made directly before safety time 1 commences (end of phase 39).

Standard valve proving (parameter 236 = 1)

If the gas pressure is too low, startup is aborted in phase 22.

No.	Parameter
246	Gas: Gas shortage waiting time

If gas shortage occurs with the last of the parameterized number of start attempts, the system initiates lockout.

No.	Parameter
223	Repetition limit gas pressure switch-min 1 = no repetition 2...15 = 1...14 number of repetitions 16 = constant repetition

In that case, the system with gas shortage program makes a selectable number of start attempts until lockout occurs. The waiting time from one start attempt to the next is doubled each time, starting from an adjustable waiting time.

7.5.3.7. Program stop function

To simplify the burner settings in connection with commissioning and service work, the program sequence of the LMV37.4... can be stopped at the following positions:

- 1) Air damper in prepurge position 24
- 2) Ignition position 36
- 3) Interval 1 44
- 4) Interval 2 52

The program stops are integrated in the setting sequence when the plant is commissioned (refer to chapter *Air-fuel ratio curves – settings and commissioning*). After the initial settings, program stops can be activated on the parameter level.

No.	Parameter
208	Program stop 0 = deactivated 1 = PrePurgP (Ph24) 2 = IgnitPos (Ph36) 3 = Interv1 (Ph44) 4 = Interv2 (Ph52)

The program stop function is maintained until manually deactivated. If the system halts at one of the program stops, a message appears on the display of the AZL2...

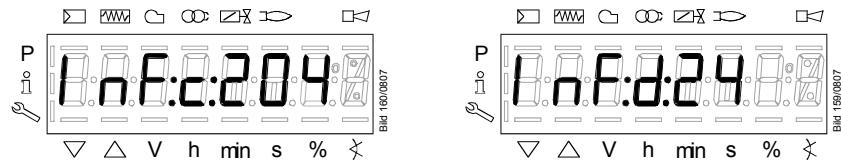

Example: **c:204** alternating with **d:24** corresponds to a program stop in the prepurge position.

Figure 27: Message in the case of program stop

7.5.3.8. Forced intermittent operation (<24 hours)

When forced intermittent operation is activated, the unit shuts down for a moment after 23 hours and 45 min of uninterrupted operation, followed by an automatic restart.

Forced intermittent operation is a standard feature.

No.	Parameter
239	Gas: Forced intermittent operation 0 = deactivated 1 = activated
279	Oil: Forced intermittent operation 0 = deactivated 1 = activated

7.5.3.9. Low-fire shutdown

To prevent the boiler from being shut down under full or nearly full load conditions, electronic air-fuel ratio control can run the burner to the low-fire position first when there is no more request for heat (refer to chapter *End of operating position*).

7.5.3.10. Continuous fan

With burners that can be damaged by heat (e.g. several burners using the same combustion chamber), continuous purging may be required. In that case, the fan operates continuously in all phases.

For that purpose, the fan motor contactor is to be connected to X3-05, pin 3, tapped after the unit fuse and the safety loop.

For checking the air pressure switch, a pressure switch relief valve must be connected to fan motor contactor X3-05, pin 1. When output X3-05, pin 1, is activated, the relief valve diverts the fan pressure to the air pressure switch and, when deactivated, ensures that no pressure is fed to the switch.

Example:

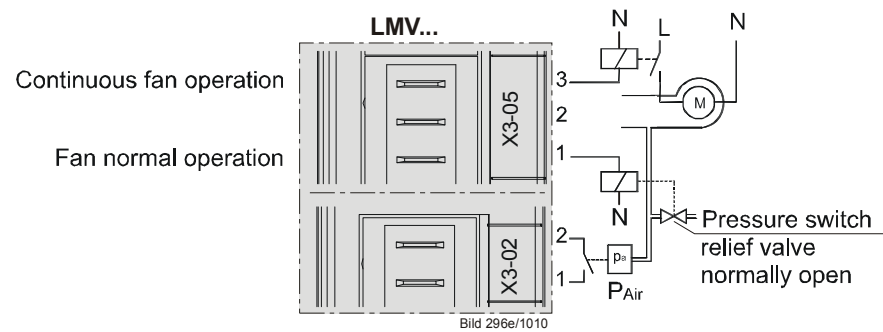

Figure 28: Continuous fan

7.5.3.11. Test function for approval of burner – loss-of-flame test (TÜV test)

The purpose of this test is to verify the detection time required in the event of loss of flame when applying for burner approval. When starting the test, the fuel valves are shut to determine the time (resolution of 0.2 seconds) until the basic unit detects loss of flame.

Procedure:

- Determine the burner output at which the test shall be made, using parameter 133 (fuel 0) or parameter 134 (fuel 1). If these parameters are not set, the test is carried out at the current output of the system
- Start the test by entering value 1 for parameter 124.
If the burner's output was defined for the test (parameter 133 or 134), the system runs to that output first. To implement this function, the default value of parameter 121 (manual output) is used. This cancels any manual output that was previously active
- Now, the LMV37.4... shuts the fuel valves, leading to loss of flame
- The evaluation is made by the basic unit by measuring the time the system requires from fuel valve shutdown until loss of flame is detected.
Then, the required time is displayed in the form of diagnostic code C:7 (loss of flame)

The resolution is 0.2 seconds.

Example

When the display reads C:7 D:10, the time required from valve shutdown to detection of loss of flame is 2 seconds (D:10 means $10 \times 0.2 = 2$ seconds).

When the test is successfully completed, parameter 124 is reset to 0. If unsuccessful, a negative value is delivered for diagnostic purposes and error code 150 is entered.

- 1 = invalid phase (test only possible in phase 60) – display reads C:150 D: 1
- 2 = default output < minimum output – display reads C:150 D:2
- 3 = default output > maximum output – display reads C:150 D:3
- 4 = manual abortion (no error, start variable was manually reset to 0) – display reads C:150 D:4
- 5 = timeout during TÜV test (no loss of flame after shutdown of valves within 50 seconds) – lockout C:150 D:5

Previously set output values at which the test shall be made (parameter 133 or 134) remain stored.

7.5.3.12. Purging in the lockout position

Parameter 190 can be used to move the actuators (actuators or VSD) to the postpurge position while they are in the lockout position.

No.	Parameter
190	Postpurging in lockout position 0 = deactivate (no-load position) 1 = active (postpurge position) When active, the <i>Alarm in the event of start prevention</i> function (parameter 210) is only possible to a limited extent!



Note!

The LMV37.4 system simply moves the actuators (actuators or VSD) to the postpurge position. A fan or VSD release contact cannot be controlled, as the alarm relay of the LMV37.4 system cuts off the power supply to the outputs. With the *Alarm in the event of start prevention* function, an external circuit that may be present for controlling the fan / VSD release contact for purging in the lockout position is activated via start prevention in standby mode.

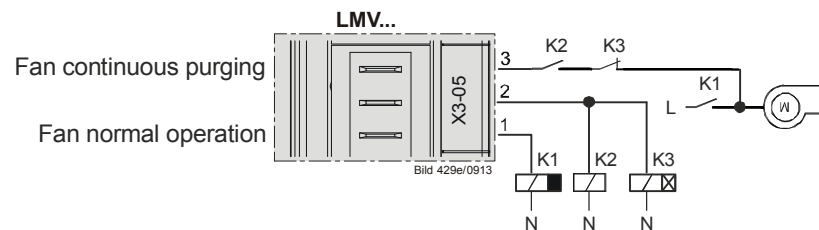

Figure 29: Application example of purging in the lockout position with fan but without VSD

The duration of purging in the lockout position can be set via the delay time of K3.



Attention!

When the *Purging in the lockout position* function is used, the fan may only be powered via a contactor and must not be connected directly to LMV37.4 (X3-05 pin 1)!

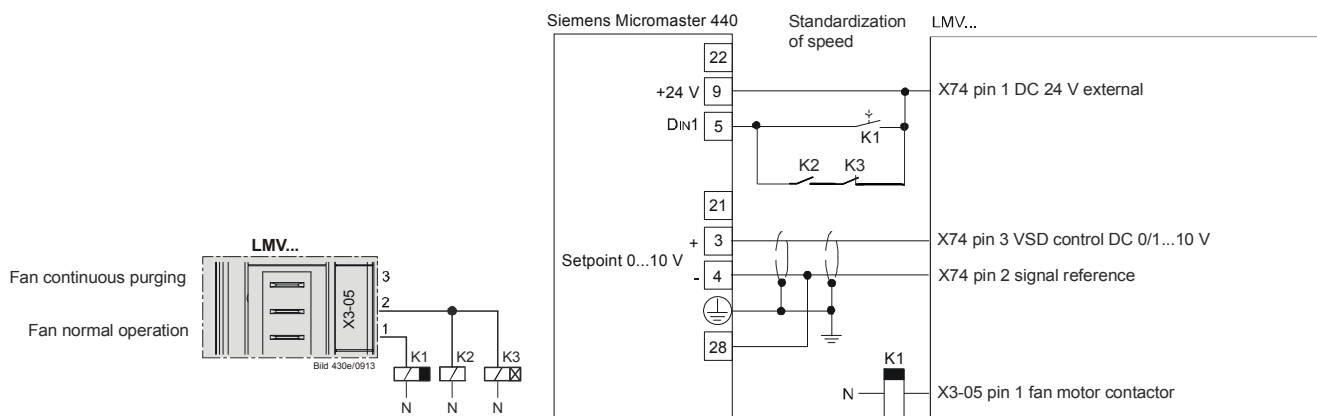

Figure 30: Application example of purging in the lockout position with fan and VSD release contact

The duration of purging in the lockout position can be set via the delay time of K3.



Attention!

When the *Purging in the lockout position* function is used, the fan may only be powered via a contactor and must not be connected directly to LMV37.4 (X3-05 pin 1)!

7.5.3.13. Switching back to pilot

The function must be selected with parameter 191. This deactivates the OPEN / CLOSE load controller contacts (X5-03 pin 2 or 3). Contact X5-03 pin 2 is evaluated as the input signal for *Switching back to pilot*. The function can be started either by a low or high signal. Both the minimum and maximum dwelling time can be set for the pilot flame via time parameters.

No.	Parameter
191	<i>Switching back to pilot</i> 0 = deactivate 1 = active (low active) 2 = active (high active) Load controller contacts X5-03 are deactivated when function is active!
192	<i>Switching back to pilot</i> minimum time
193	<i>Switching back to pilot</i> maximum time



Note!

Once the OPEN / CLOSE load controller contacts have been deactivated, the analog input is the lowest-priority power source. The system response when the analog signal is interrupted can be performed via parameter 204 (low-fire or shutdown and start prevention).

No.	Parameter
204	Analog output invalid (4...20 mA) 0 = default load low-fire 1 = safety shutdown + start prevention

Sequence following activation of input signal in operation (phase 60) – (also refer to *Sequence diagram*):

1. Phase 64: Modulation to ignition load
2. Phase 65: Interval 2 waiting time (stabilization time)
3. Phase 66: Reactivation of ignition and pilot valve (duration of safety time TSA1)
4. Phase 67: Shutdown of the main valves (duration of safety time TSA1, including blind circuit for pressure switch-min / -max)
5. Phase 68: Pilot mode waiting phase (pilot minimum time / pilot maximum time)

The LMV37.4 system is restarted (via safety time TSA2) when the input signal no longer exists.

Shutdown of the LMV37.4 system in the event of:

- Controller OFF
- Maximum pilot time exceeded (maximum setting 108 minutes)
- Forced intermittent operation after 24 hours

When the input signal is active during startup, the LMV37.4 system waits in phase 69 (interval 1). While the switching back to pilot function is in use, the remaining time to shutdown is displayed via the maximum time in the AZL2.



Note!

A user intervention has top priority. This means that an active curve setting or preselected manual output (signaled by flashing output display) prevents the switching back to pilot function from being activated.

The restarts from the pilot waiting phase are counted in the startup counter (parameter 176).

No.	Parameter
176	Switching back to pilot switching cycles

RWF40 / RWF55 application examples:

The setting must be set to low active to use the RWF40 / RWF55. The controller ON signal (X5-03 pin 1 / pin 4) is applied at RWF40 (contacts Q13 and Q14) or at RWF55 (contacts 1P and 1N). The signal for switching back to pilot (X5-03 pin 2) is connected to RWF40 (contacts Q63 and Q64) and to RWF55 (contacts 6N and 6P). Function **Ik5** must be selected at RWF40 / RWF55.

The output is preselected via a 4...20 mA analog signal.

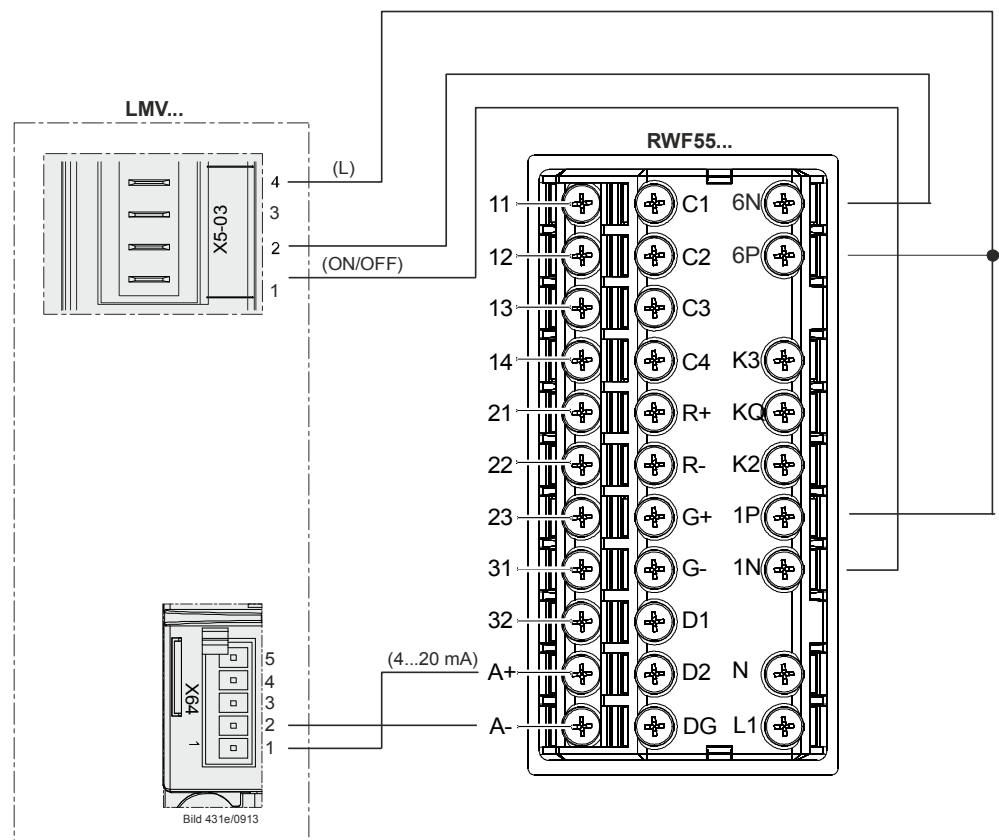

Figure 31: Wiring LMV37... with universal controller RWF55...

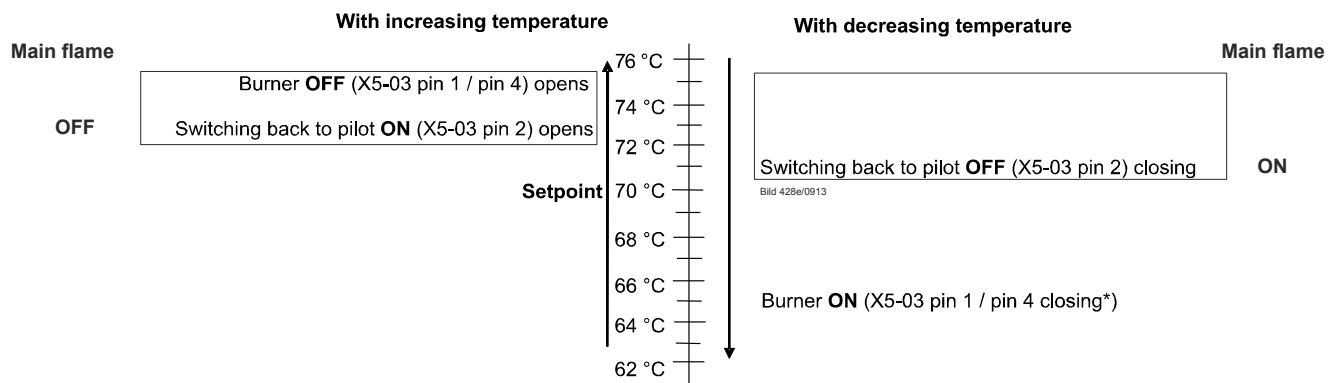

Figure 32: Switching back to pilot sequence in connection with an RWF40 / RWF55 controller

*) The burner ON threshold is only active when switching on (cold start)

The *Switching back to pilot* function is active in the marked temperature zone. If the temperature increases above the ON threshold, the *Switching back to pilot* function is activated. The main flame is shut down at the same time. If the temperature decreases in the direction of the setpoint, the *Switching back to pilot* function remains active until the temperature falls below the OFF threshold. The main flame is switched back on.

7.6 Fuel trains (application examples)

Gas direct ignition
(Operating mode 1, 7, 14, 19)

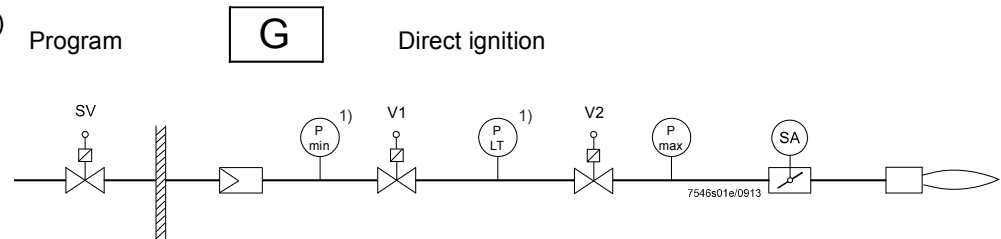

Figure 33: Gas direct ignition

Gas pilot ignition 1
(Operating mode 2, 8, 15, 20)

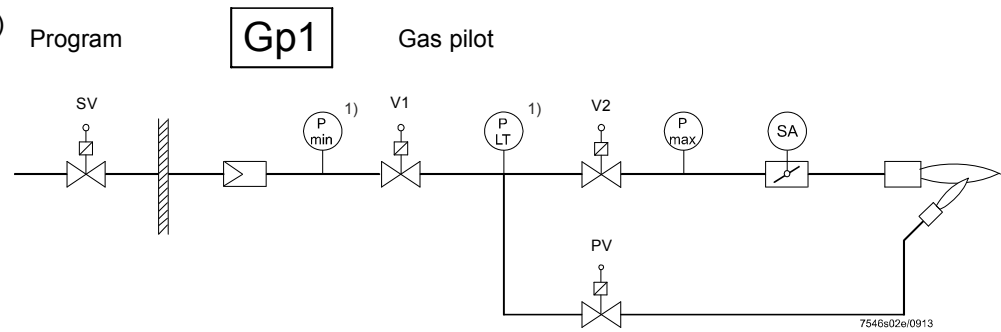

Figure 34: Gas pilot ignition 1

Gas pilot ignition 2
(Operating mode 3, 9, 16, 21)

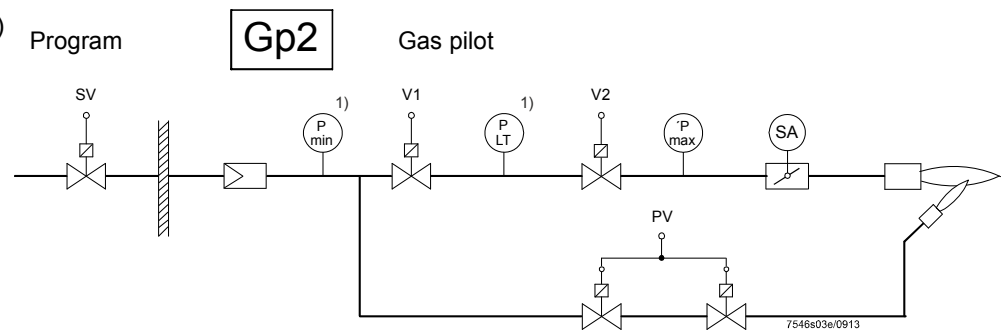

Figure 35: Gas pilot ignition 2

Fuel valve control program Gas (always modulate)

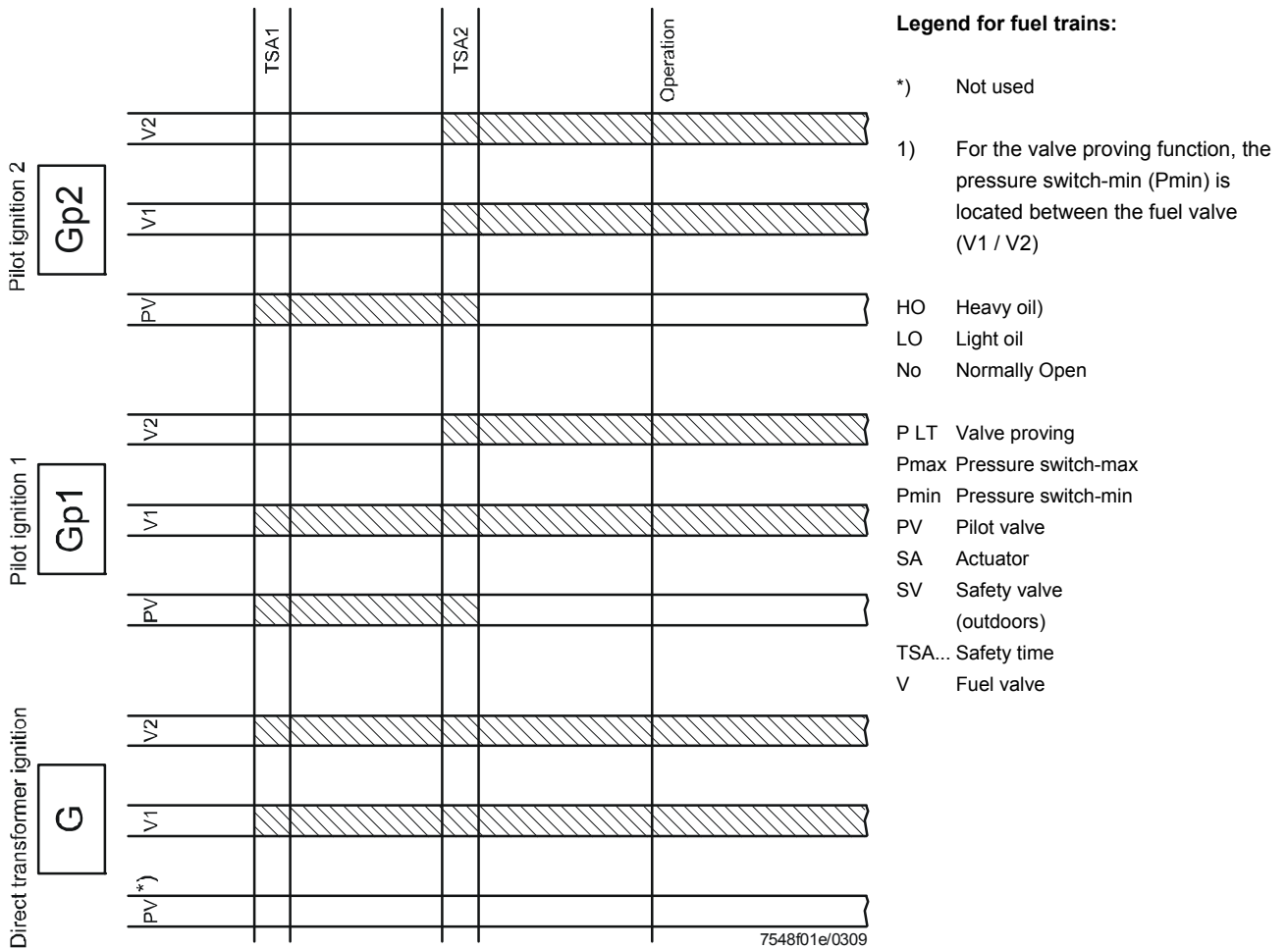

Figure 36: Gas – fuel valve control - program

Light oil direct ignition,
multistage
(Operating mode 5, 17)

1-stage burner

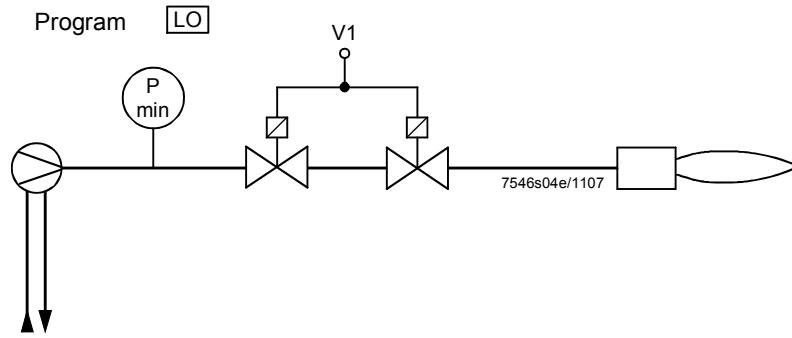

Figure 37: Light oil direct ignition, multistage

(Operating mode 5, 17)

2-stage burner

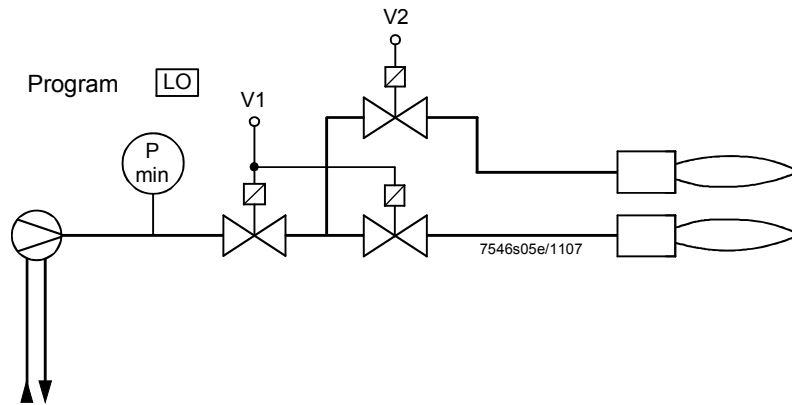

Figure 38: Light oil direct ignition, 2-stage

(Operating mode 6, 18)

3-stage burner

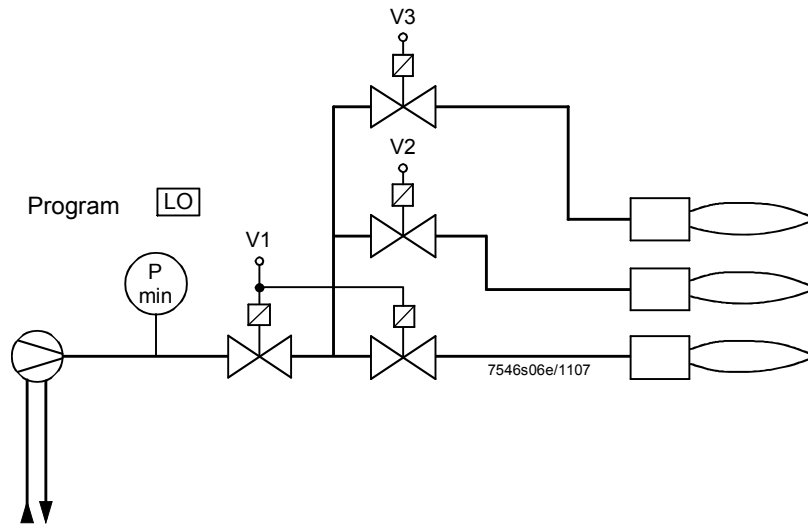

Figure 39: Light oil direct ignition, 3-stage

Light oil direct ignition,
modulating
(Operating mode 4, 22)

Modulating burner (without shutdown facility for adjustable head)

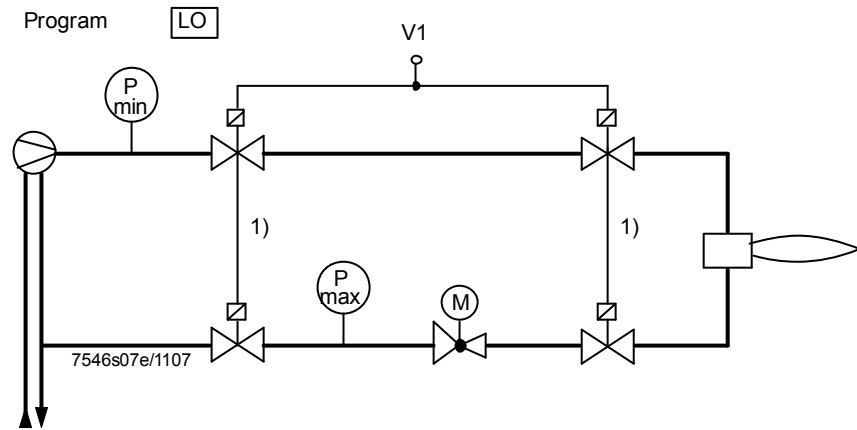

Figure 40: Light oil direct ignition, modulating

(Operating mode 4, 22)

Modulating burner (with shutdown facility for adjustable head)

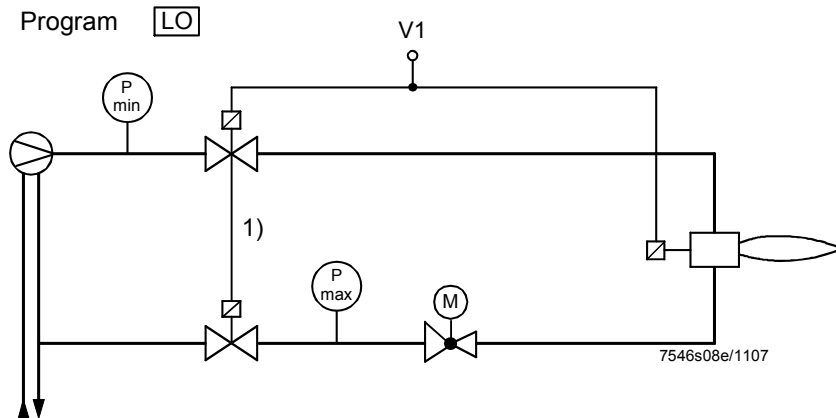

Figure 41: Light oil ignition, modulating

Fuel valve control program

Light oil (transformer for direct ignition) and heavy oil without separate Circulation control (transformer direct ignition)

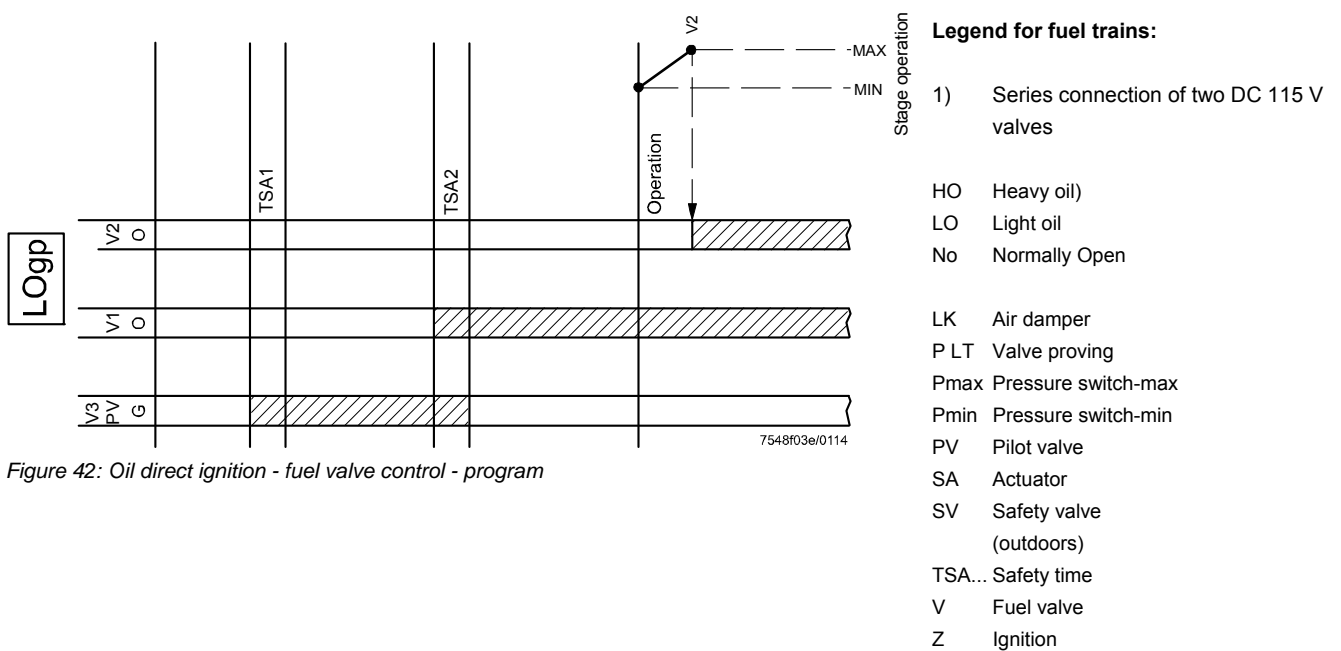

Figure 42: Oil direct ignition - fuel valve control - program

Light oil direct ignition
modulating with 2 fuel valves
(Operating mode 12)

Modulating burner (without shutdown facility for adjustable head)

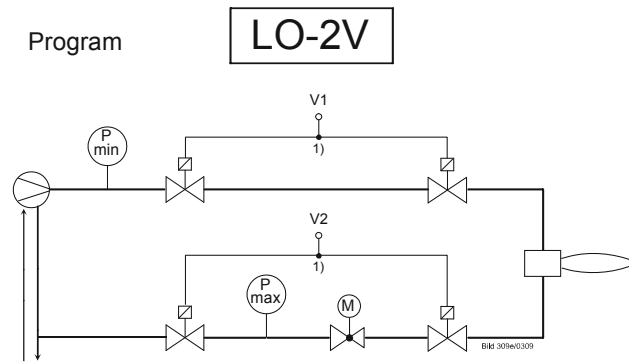

Figure 43: Light oil direct ignition, modulating, without shutdown facility for adjustable head

(Operating mode 12)

Modulating burner (with shutdown facility for adjustable head)

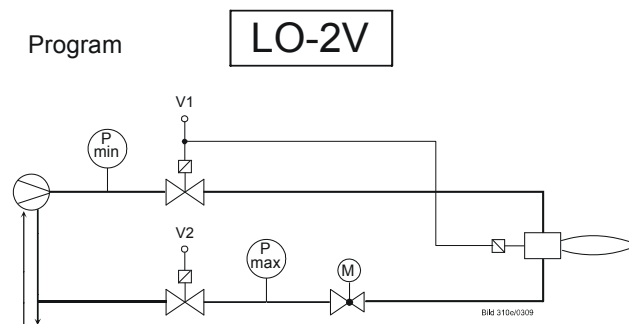

Figure 44: Light oil direct ignition, modulating, with shutdown facility for adjustable head

Fuel valve control program Light oil (transformer for direct ignition)

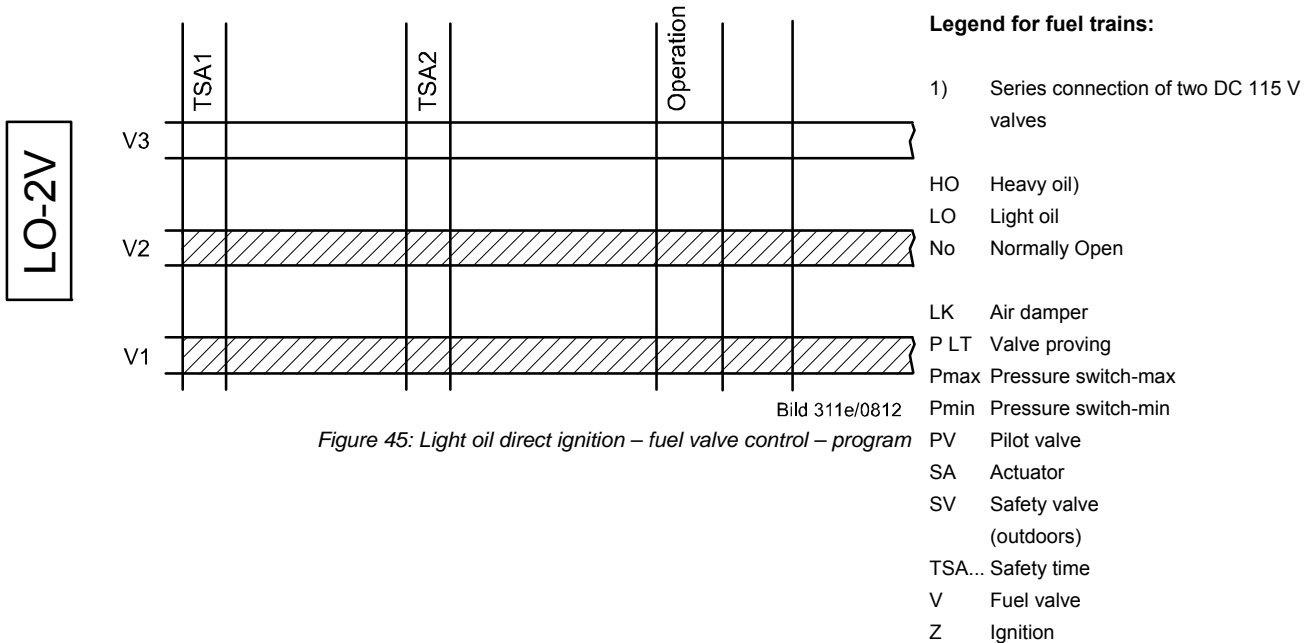

Figure 45: Light oil direct ignition – fuel valve control – program

Light oil with gas pilot ignition

(Operating mode 3, 9, 16, 21)

Program

LOGp

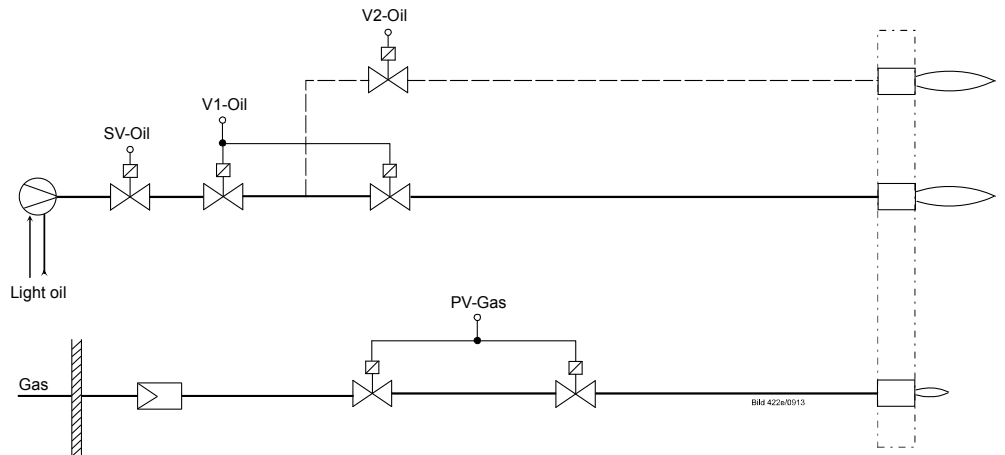

(Operating mode 10, 11)

Figure 46: Light oil with gas pilot ignition

Fuel valve control program Light oil (with gas pilot ignition)

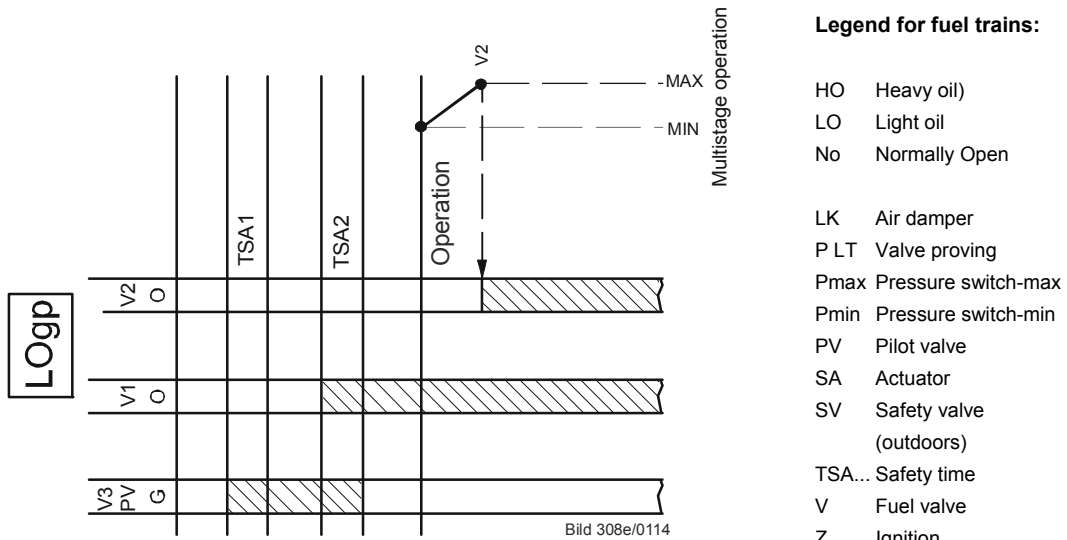

Figure 47: Light oil with gas pilot ignition – fuel valve control - program

Light oil with gas pilot ignition
with 2 fuel valves

(Operating mode 3, 9, 16, 21)

Program

LOgp-2V

(Operating mode 13)

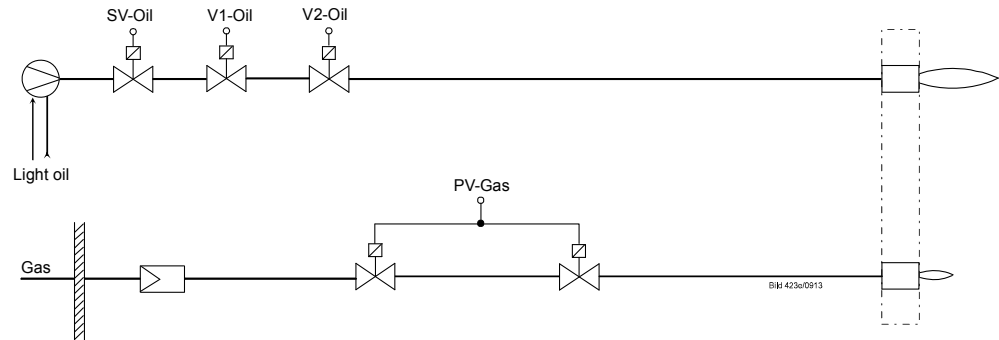

Figure 48: Light oil with gas pilot ignition

Fuel valve control program

Light oil (with gas pilot ignition)

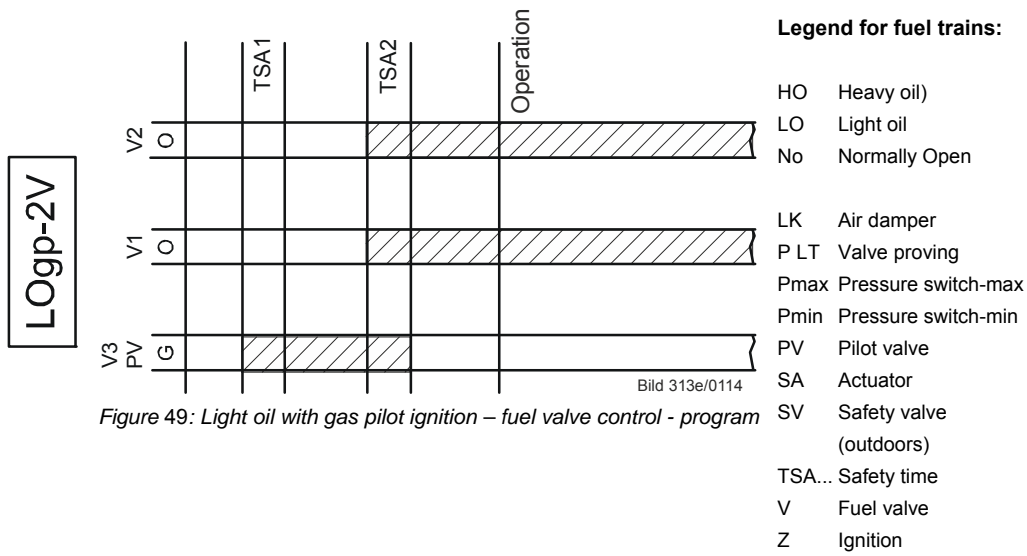

Figure 49: Light oil with gas pilot ignition – fuel valve control - program

Heavy oil direct ignition,
multistage

(Operating mode 24)

2-stage burner

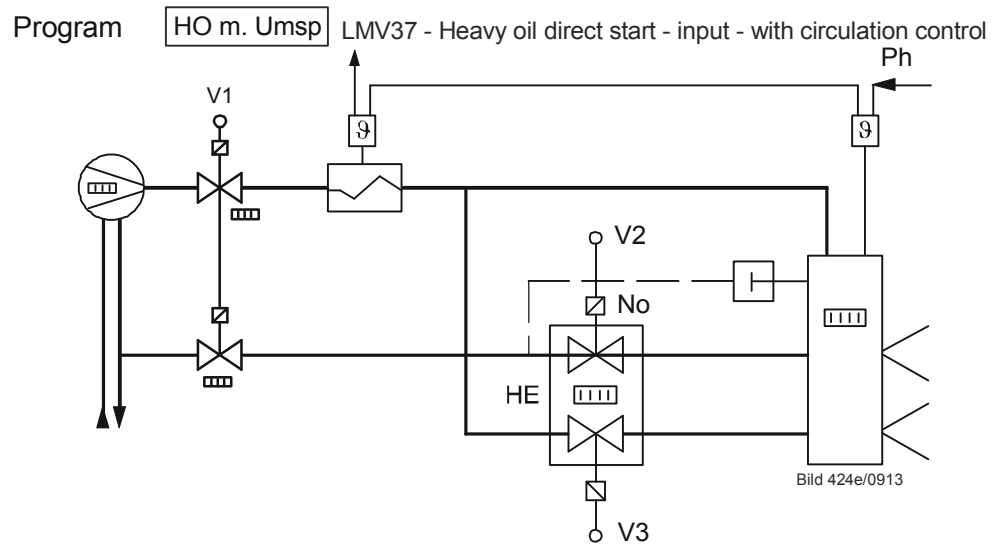

Figure 50: Heavy oil direct ignition, 2-stage, with circulation control

Heavy oil direct ignition,
modulating

(Operating mode 23)

Modulating burner

Circulation from phase 38, maximum 45 seconds as soon as direct heavy oil start = ON in phase 38:

→ Phase change in phase 40

Direct heavy oil start = OFF at the end of phase 38:

→ Repetition (a maximum of 3 times)

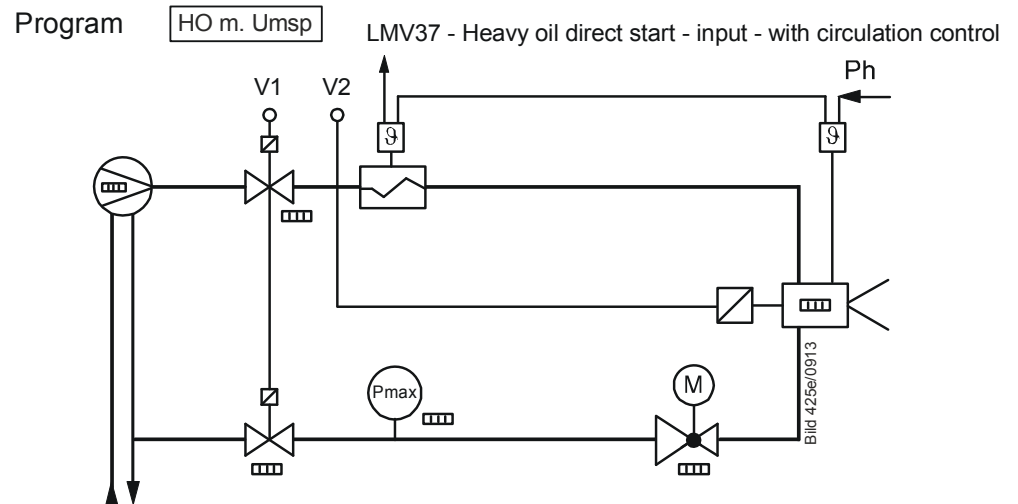

Figure 51: Heavy oil direct ignition, modulating, with circulation control

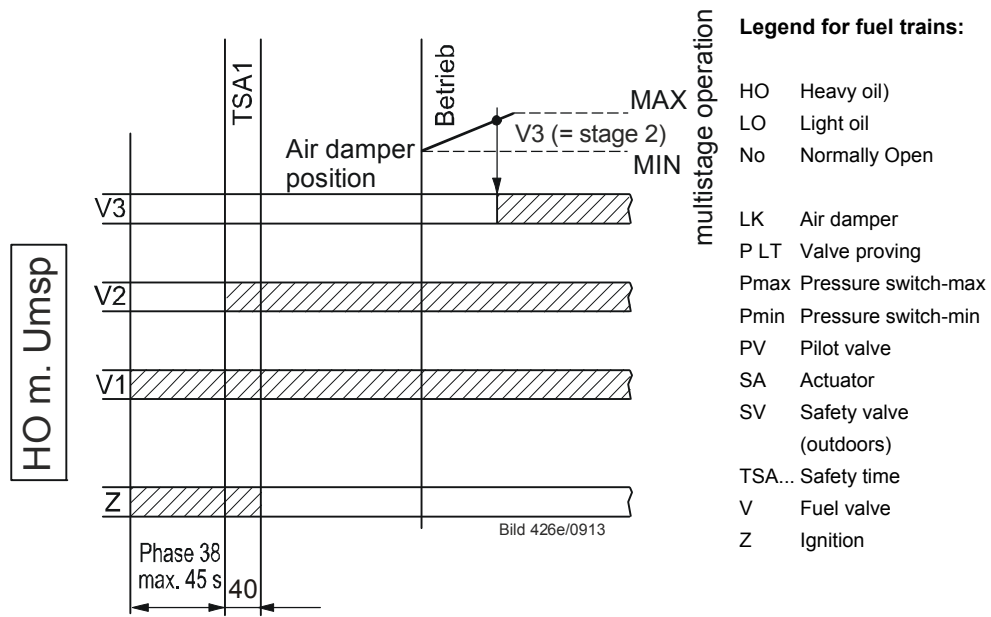

Figure 52: Heavy oil direct ignition – fuel valve control - program

7.7 Sequence diagrams

The phase numbers given in the sequence diagrams can be read from the following process data:

No.	Parameter
961	Phase (state of external module and display)

7.7.1 Gas direct ignition «G», «G mod», «G mod pneu»



Bild 06e/0913

Figure 53: Program for gas direct ignition «G», «G mod», «G mod pneu»

7.7.2 Gas pilot ignition 1 «Gp1», «Gp1 mod», «Gp1 mod pneu»

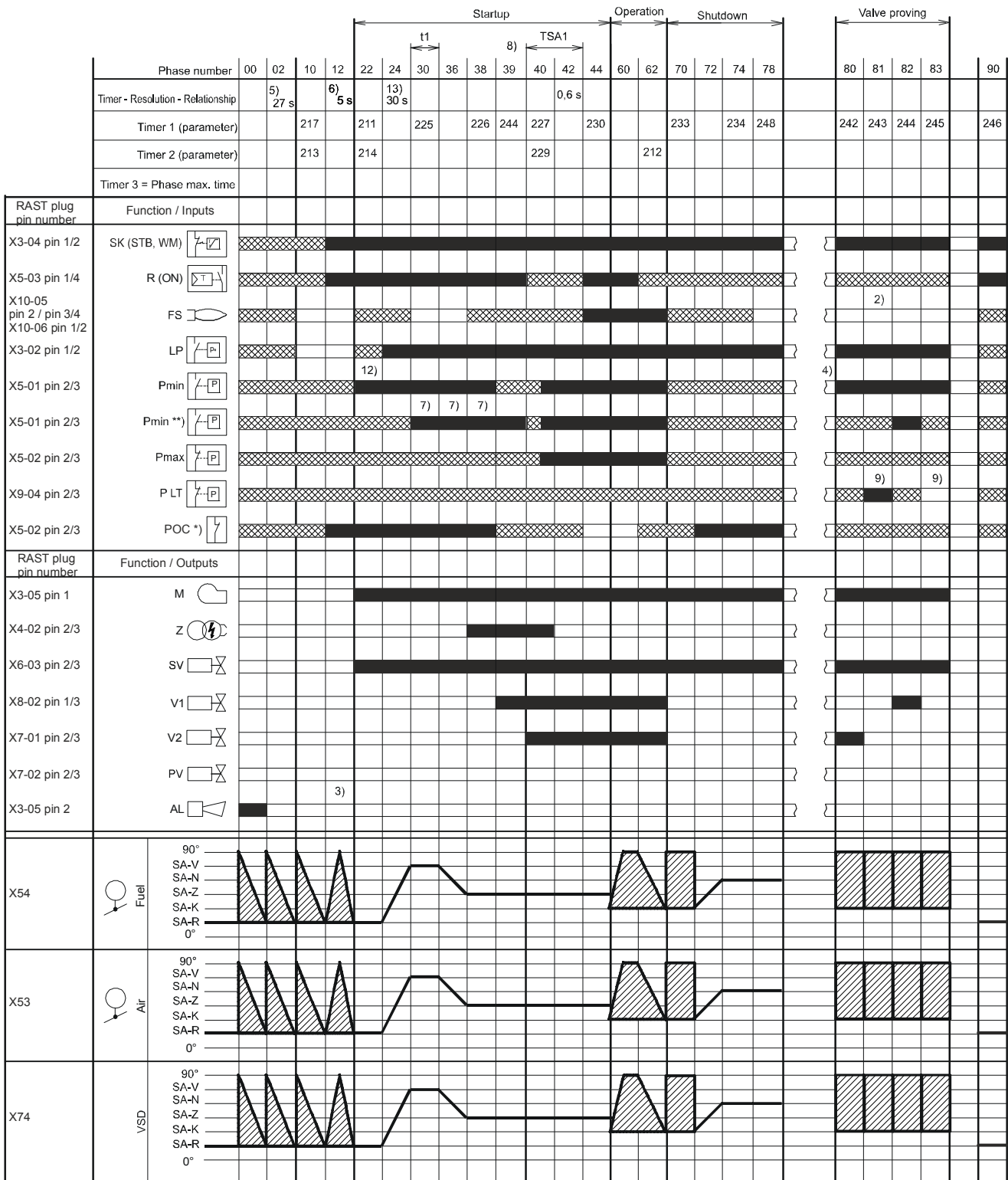

Bild 18e/0913

Figure 54: Program for gas pilot ignition «Gp1», «Gp1 mod», «Gp1 mod pneu»

7.7.3 Gas pilot ignition 2 «Gp2», «Gp2 mod», «Gp2 mod pneu»

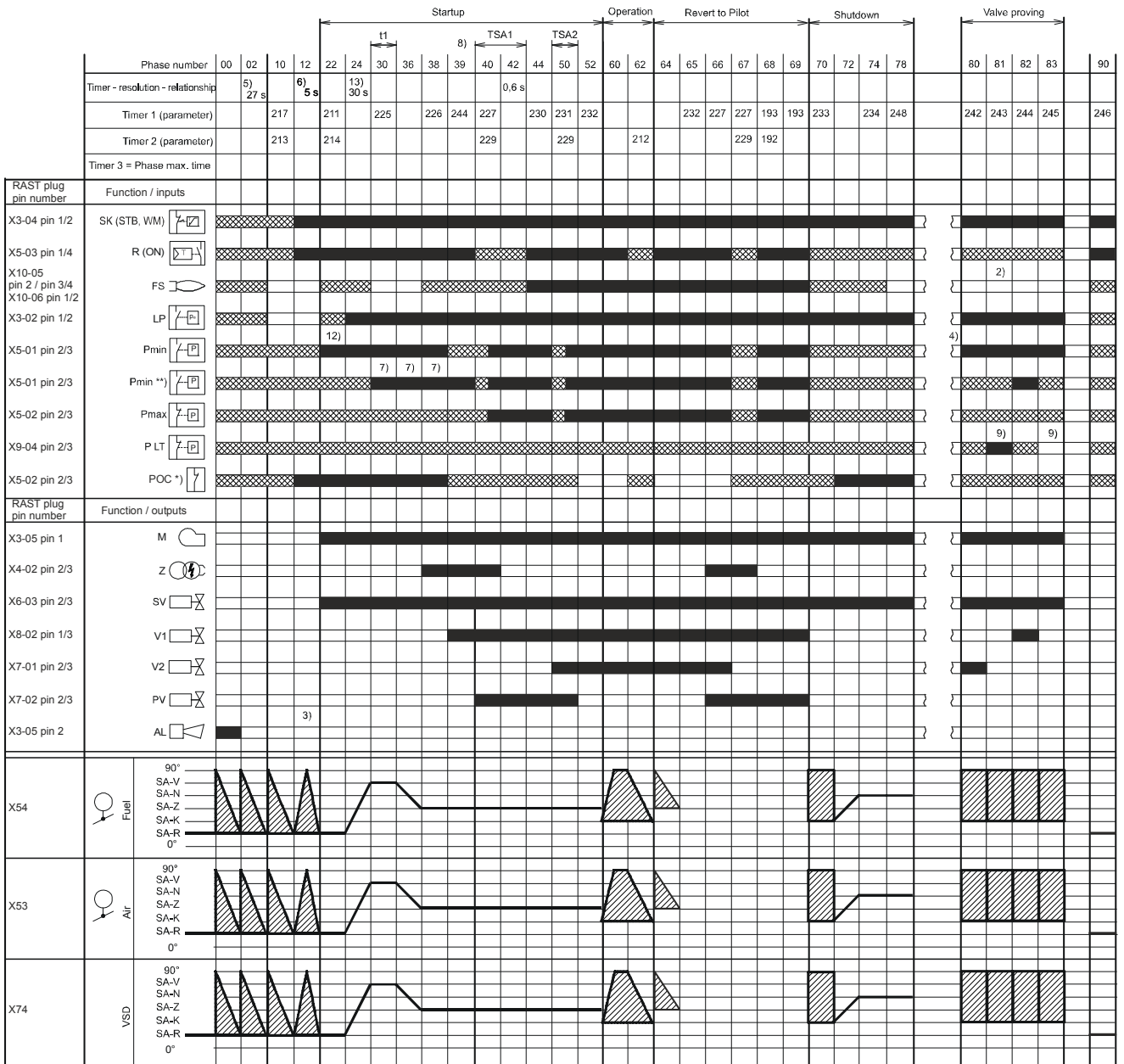

Bild 19e/0913

Figure 55: Program for gas pilot ignition «Gp2», «Gp2 mod», «Gp2 mod pneu»

7.7.4 Light oil direct ignition «Lo», «Lo mod», «Lo 2-stage», «Lo 3-stage»

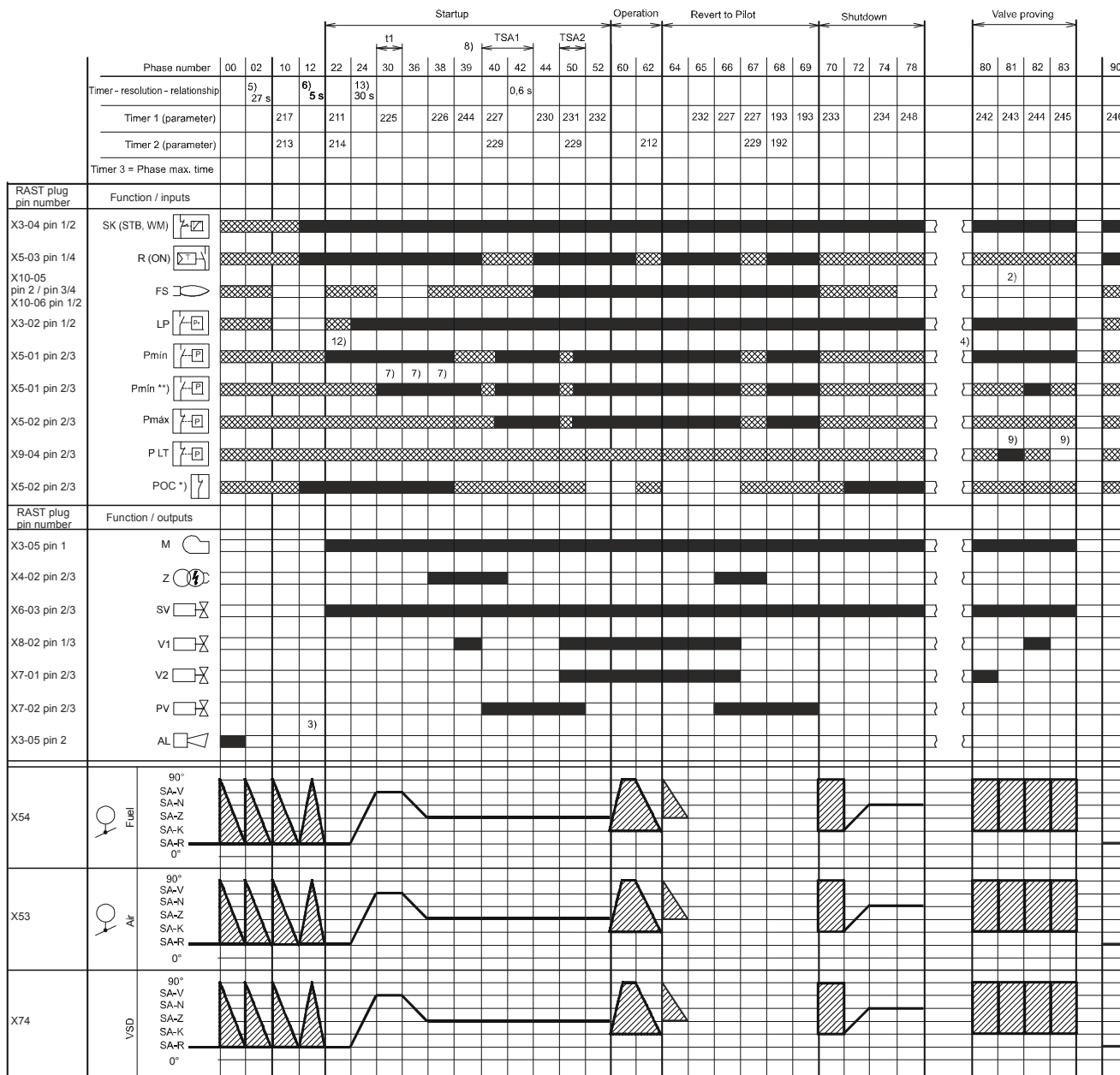

Bild 03e/1010

Figure 56: Program for light oil «Lo», «Lo mod», «Lo 2-stage», «Lo 3-stage»

7.7.5 Light oil pilot ignition «Lo Gp»

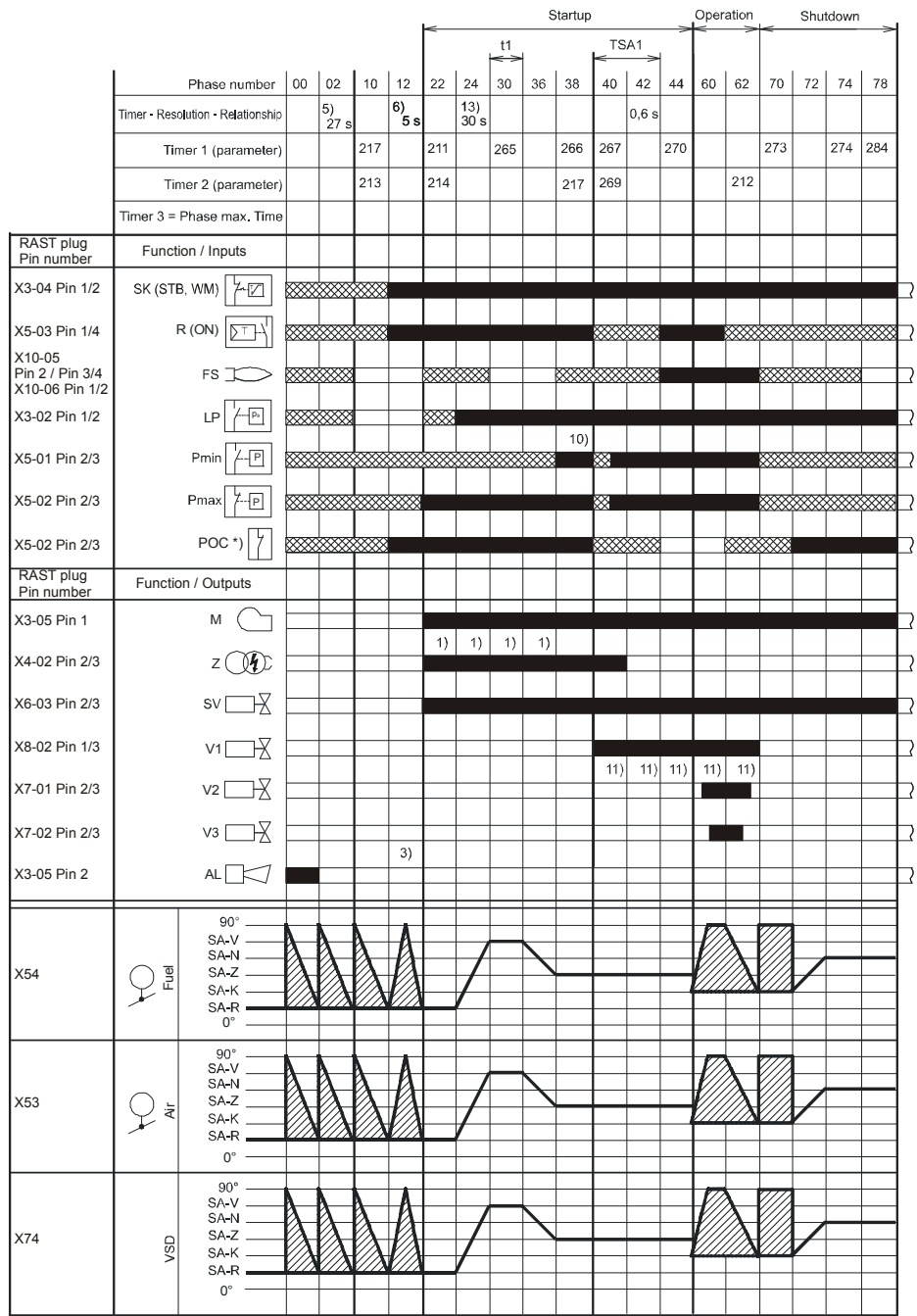

Bild 01e/0913

Figure 57: Program light oil pilot ignition (Lo Gp)

7.7.6 Heavy oil direct ignition «HO», «HO m. Umsp mod», «HO m. Umsp 2-stage» with separate circulation control

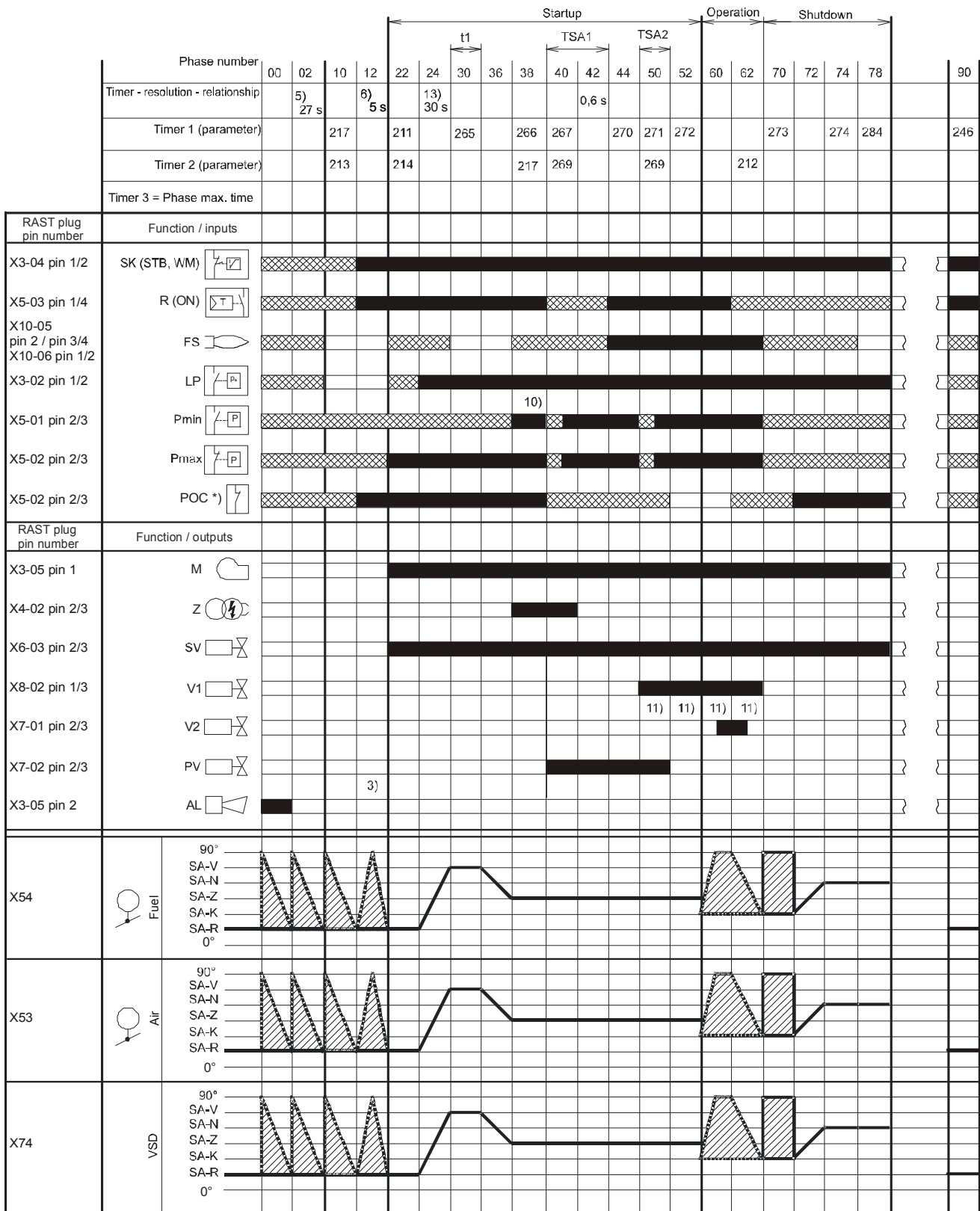

Bild 16e/0913

Figure 58: Program Heavy oil direct ignition «HO», «HO m. Umsp mod», «HO m. Umsp 2-stage»

7.7.7 Heavy oil direct ignition «HO», «HO o. Umsp mod», «HO o. Umsp 2-stage», «HO o. Umsp 3-stage» without separate circulation control

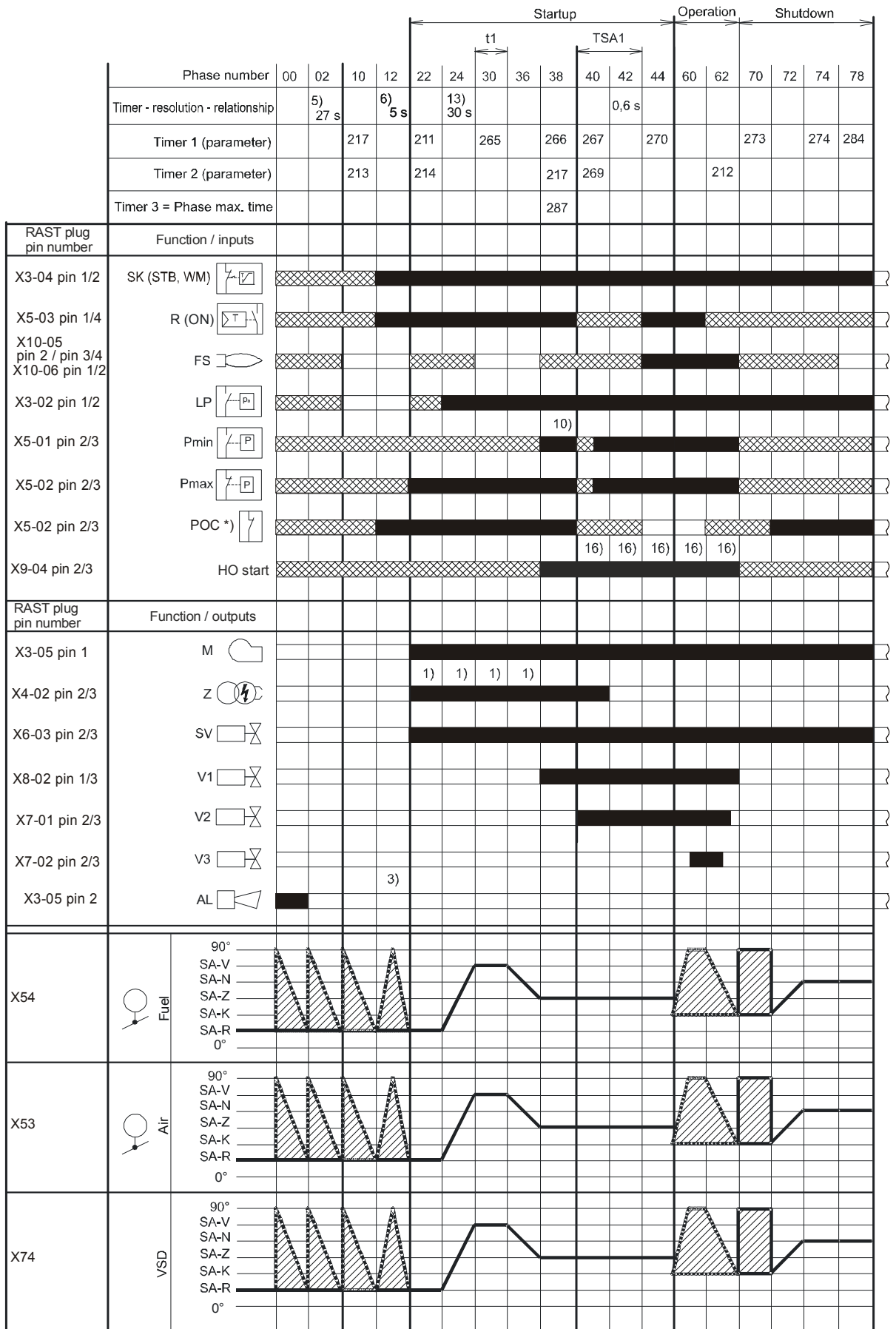

Bild 17e/0913

Figure 59: Program heavy oil direct ignition «HO», «HO o. Umsp mod», «HO o. Umsp 2-stage», «HO o. Umsp 3-stage»

7.7.8 Legend to the sequence diagrams

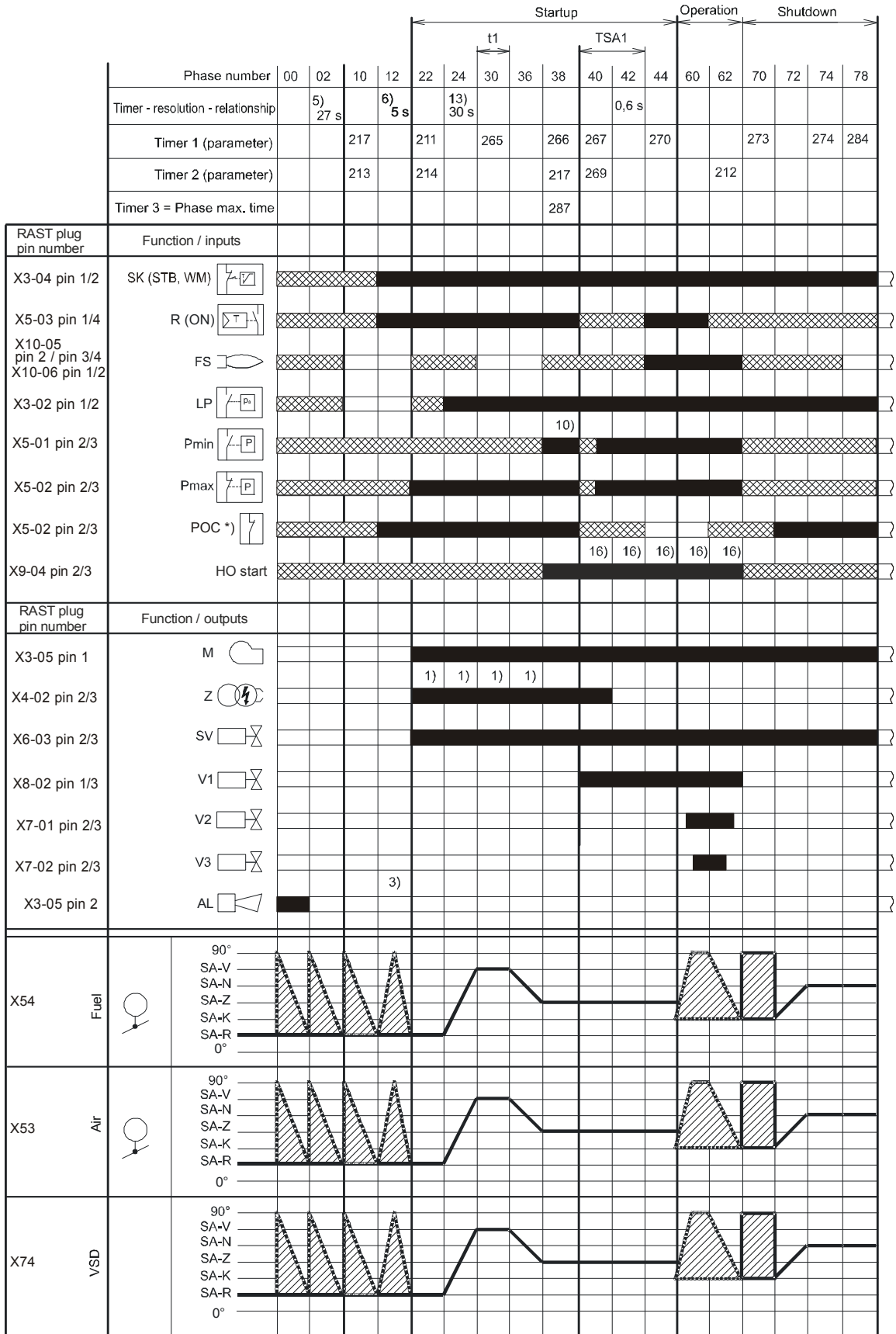

Note

Not all phases, times, indices, abbreviations and symbols appear in the individual sequence diagrams or are needed there!

Phase numbers

00	Lockout phase
02	Safety phase
10	Home run
12	Standby (stationary)
22	Fan motor (M) = ON, safety valve (SV) = ON
24	Air damper (LK) ⇒ fuel valve (V) – position
30	Prepurging
36	Air damper (LK) ⇒ ignition (Z) – position
38	Preignition ignition (Z) = ON
39	Test pressure switch-min (Pmin)
40	Fuel valve (V) = ON
42	Ignition (Z) = OFF
44	Interval 1 (t44)
50	Safety time 2 (TSA2)
52	Interval 2 (t52)
60	Operation 1 (stationary)
62	Operation 2 air damper (LK) ⇒ low-fire (KL) – position
64	Switching back to pilot: Modulation to ignition load
65	Switching back to pilot: Interval 2 waiting time
66	Switching back to pilot: Reactivation of ignition + pilot
67	Switching back to pilot: Shutdown of main valves
68	Switching back to pilot: Pilot mode waiting phase
69	Switching back to pilot: Pilot mode waiting phase for burner startup
70	Afterburn time (t13)
72	Air damper (LK) ⇒ Rated load (NL) – position
74	Postpurge time (t8)
78	Postpurge time (t3)
80	Evacuation of test space
81	Atmospheric pressure test
82	Filling of test space
83	Gas pressure test
90	Gas shortage waiting time

Valve proving is performed depending on the parameter settings:
Simultaneously with the prepurge time and/or the afterburn time.

Times

TSA1	1st safety time
TSA2	2nd safety time
t1	Prepurge time
t3	Postpurge time
t8	Postpurge time
t13	Afterburn time
t44	Interval 1
t52	Interval 2

Indices

1)	Parameter:	Short/long prepurge time for oil only Short/long on time of oil pump – time
2)		Only with valve proving during startup
3)	Parameter:	With/without alarm in the event of start prevention
4)		If signal is faulty in the startup phase, phase 10 is next, otherwise phase 70
5)		Max. time safety phase, then lockout
6)		Time from occurrence of start prevention to signaling
7)		Only in case of valve proving during startup (valve proving via pressure switch-min)
8)		Only in case of startup without valve proving (valve proving via pressure switch -min)
9)		Inverse logic in case of valve proving via pressure switch-min
10)	Parameter 276:	Oil pressure min-input 1 = active from phase 38 2 = active from safety time
11)		Only with fuel train <i>Lo</i> and 2 fuel valves
12)	Parameter 223:	Repetition limit value gas pressure switch-min in connection with gas shortage program parameter 246 (phase 90)
13)		Max. drop-in/response time for air pressure switch
14)		Alternative to valve proving
15)		Alternative to pressure switch-max (Pmax) or POC
16)	Parameter 286:	Evaluation of heavy oil direct start 0 = only start signal in phase 38 1 = evaluation in phase 38...62

Abbreviations

AL	Alarm
FS	Flame signal
GM	Fan motor contactor
LP	Air pressure switch
M	Fan motor
P LT	Pressure switch for valve proving
Pmax	Pressure switch-max
Pmin	Pressure switch-min
POC	Proof of closure
PV	Pilot valve
R	Temperature or pressure controller
SB	Safety limiter
SK	Safety loop
STB	Safety limit thermostat
SV	Safety valve
WM	Water shortage
V1	Fuel valve 1
V2	Fuel valve 2
VP	Combustion pressure switch
Z	Ignition transformer
SA	Actuator
SA-K	Low-fire position of actuator
SA-N	Postpurge position of actuator
SA-R	Home position of actuator
SA-V	Rated load position of actuator
SA-Z	Ignition load position of actuator

Symbols



Permissible position range



In *Standby* mode: Actuator is allowed to travel within the permissible position range, but is always driven to the home position; must be in the home position for phase changes

0°/10%
90°/100%

Position as supplied (0°)
Actuator fully open (90°)



Input/output signal 1 (ON)
Input/output signal 0 (OFF)
Input permissible signal 1 (ON) or 0 (OFF)

*)
**)

Alternative to pressure switch-max (Pmax)
Only with valve proving via pressure switch-min (Pmin)

8 Selection of operating mode

To facilitate straightforward adaptation of the LMV37.4... to different types of burners, the system offers automatic configuration of the operating mode. This means that – derived from parameter 201 – the most important settings relating to the operating mode are made automatically. Very often in that case, the only manual settings to be made are those for the air-fuel ratio control system. After selection of the operating mode, parameters that are not required will be hidden (e.g. oil parameters when firing on gas).

No.	Parameter
201	Burner operating mode (fuel train, modulating / multistage, actuators, etc.) -- = undefined (delete curves) 1 = G mod 2 = Gp1 mod 3 = Gp2 mod 4 = Lo mod 5 = Lo 2-stage 6 = Lo 3-stage 7 = G mod pneu 8 = Gp1 mod pneu 9 = Gp2 mod pneu 10 = LoGp mod 11 = LoGp 2-stage 12 = Lo mod 2 fuel valves 13 = LoGp mod 2 fuel valves 14 = G mod pneu without actuator 15 = Gp1 mod pneu without actuator 16 = Gp2 mod pneu without actuator 17 = Lo 2-stage without actuator 18 = Lo 3-stage without actuator 19 = G mod only gas actuator 20 = Gp1 mod only gas actuator 21 = Gp2 mod only gas actuator 22 = Lo mod only oil actuator 23 = HO mod with circulation 24 = HO 2-stage with circulation 25 = HO mod without circulation control 26 = HO 2-stage without circulation control 27 = HO 3-stage without circulation control

Operating mode parameter 201	Fuel train	Air-fuel ratio control	Fuel actuator	Air actuator	Feedback signal VSD	Description
1	G mod	Modulating electronic	●	●	●	Gas direct ignition, modulating electronic air-fuel ratio control Optional with VSD with speed feedback signal
2	Gp1 mod	Modulating electronic	●	●	●	Gas pilot ignition 1, modulating electronic air-fuel ratio control Optional with VSD with speed feedback signal
3	Gp2 mod	Modulating electronic	●	●	●	Gas pilot ignition 2, modulating electronic air-fuel ratio control Optional with VSD with speed feedback signal
4	Lo mod	Modulating electronic	●	●	●	Oil direct ignition, modulating electronic air-fuel ratio control Optional with VSD with speed feedback signal
5	Lo 2 stage	2-stage		●	●	Oil direct ignition, electronic 2-stage air-fuel ratio control Optional with VSD with speed feedback signal
6	Lo 3 stage	3-stage		●	●	Oil direct ignition, electronic 3-stage air-fuel ratio control Optional with VSD with speed feedback signal
7	G mod pneu	Modulating pneumatic		●		Gas direct ignition, modulating pneumatic air-fuel ratio control Optional with VSD without speed feedback signal
8	Gp1 mod pneu	Modulating pneumatic		●		Gas pilot ignition 1, modulating pneumatic air-fuel ratio control Optional with VSD without speed feedback signal
9	Gp2 mod pneu	Modulating pneumatic		●		Gas pilot ignition 2, modulating pneumatic air-fuel ratio control Optional with VSD without speed feedback signal
10	Lo Gp mod	Modulating electronic	●	●	●	Oil pilot ignition, modulating electronic air-fuel ratio control Optional with VSD with speed feedback signal
11	Lo Gp 2 stage	2-stage		●	●	Oil pilot ignition, electronic 2-stage air-fuel ratio control. Optional with VSD with speed feedback signal
12	Lo mod 2V	Modulating electronic	●	●	●	Oil direct ignition, two fuel valves, modulating electronic air-fuel ratio control. Optional with VSD with speed feedback signal
13	Lo Gp mod 2V	Modulating electronic	●	●	●	Oil pilot ignition, two fuel valves, modulating electronic air-fuel ratio control. Optional with VSD with speed feedback signal
14	G mod pneu	Modulating pneumatic				Gas direct ignition, without actuators, modulating pneumatic air-fuel ratio control. Optional with VSD without speed feedback signal
15	Gp1 mod pneu	Modulating pneumatic				Gas pilot ignition 1, without actuators, modulating pneumatic air-fuel ratio control. Optional with VSD without speed feedback signal
16	Gp2 mod pneu	Modulating pneumatic				Gas pilot ignition 2, without actuators, modulating pneumatic air-fuel ratio control. Optional with VSD without speed feedback signal
17	Lo 2 stage	2-stage			●	Oil direct ignition, without actuators, electronic 2-stage air-fuel ratio control. Optional with VSD with speed feedback signal
18	Lo 3 stage	3-stage			●	Oil direct ignition, without actuators, electronic 3-stage air-fuel ratio control. Optional with VSD with speed feedback signal
19	G mod	Modulating	●		●	Gas direct ignition, only when firing on gas, modulating fuel actuator. Optional with VSD with speed feedback signal
20	Gp1 mod	Modulating	●		●	Gas pilot ignition 1, only when firing on gas, modulating fuel actuator. Optional with VSD with speed feedback signal
21	Gp2 mod	Modulating	●		●	Gas pilot ignition 2, only when firing on gas, modulating fuel actuator. Optional with VSD with speed feedback signal
22	Lo mod	Modulating	●		●	Oil direct ignition, only when firing on oil, modulating fuel actuator. Optional with VSD with speed feedback signal
23	HO m. Umosp mod	Modulating electronic	●	●	●	Heavy oil direct ignition with circulation, electronic modulating ratio control. Optional with VSD with speed feedback signal
24	HO m. Umosp 2-stage	2-stage		●	●	Heavy oil direct ignition with circulation, electronic 2-stage ratio control. Optional with VSD with speed feedback signal
25	HO o. Umosp mod	Modulating electronic	●	●	●	Heavy oil direct ignition without circulation control, electronic modulating ratio control. Optional with VSD with speed feedback

Operating mode parameter 201	Fuel train	Air-fuel ratio control	Fuel actuator	Air actuator	Feedback signal VSD	Description
						signal
26	HO o. Umsp 2-stage	2-stage		●	●	Heavy oil direct ignition without circulation control, electronic 2-stage ratio control. Optional with VSD with speed feedback signal
27	HO o. Umsp 3-stage	3-stage		●	●	Heavy oil direct ignition without circulation control, electronic 3-stage ratio control. Optional with VSD with speed feedback signal

(Also refer to chapter *Fuel trains*)

The VSD can be used with any of the operating modes (refer to chapter *VSD*).

No.	Parameter
542	Activation of VSD / PWM fan 0 = inactive 1 = active



Note

For configuration of the analog output when the VSD is activated, refer to chapter *Load output X74 pin 3!*

8.1 Deleting curves

To delete curves, the operating mode must be set to undefined «--». In that case, only the fuel curves are deleted, the direction of rotation or the reference position of the actuators is not changed.

9 Connection to load controllers

The LMV37.4... system can be connected to different load controllers. Heat request and the required burner output are determined in accordance with the priorities of the different load sources.

9.1 Controller on contact X5-03 pin 1

This contact is given priority over all load sources. A heat request can only be made when this contact is closed. The contact is safety-related and can also be used in connection with controllers featuring an integrated temperature limiter function.

9.2 External load controller via contacts X5-03, pin 2 / pin 3

The heat request is delivered via pin 1. Modulation of burner output is effected via pin 2 and 3. Here, a differentiation is made between modulating and multistage operation (refer to chapter *Selection of operating mode*).

Modulating operation X5-03 (OPEN pin 3 / CLOSE pin 2)

If input *Open* is active, the burner's output is increased. If input *Close* is active, the burner's output is decreased. If none of the inputs is active, the burner's output is not changed.

The rate of integration is 32 seconds for changing the output from low-fire to high-fire (parameter 544), that is from 20 % to 100 %, or vice versa.

Output integration always takes place in the operating position.

200 ms is the shortest positioning step that is securely detected.

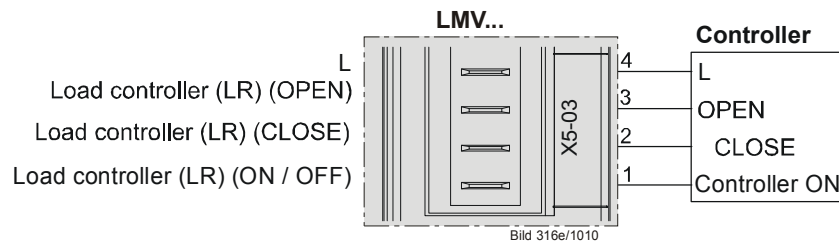

Figure 60: Modulating operation X5-03



Note!

When the *Switching back to pilot* function is used, the load controller inputs OPEN CLOSE (X5-03 pin 2 and 3) are not available (refer to chapter *Switching back to pilot*). Analog input X64 is used as the power source in this case.

Minimum positioning step

To prevent the actuators from making unnecessary position changes when the preselected target output varies, a minimum positioning step can be set. In that case, the basic unit changes the output only when the preselected target output exceeds the minimum positioning step. This minimum positioning step is only used in modulating operation.

No.	Parameter
123.2	Minimum output positioning step: Output of external load controller contacts

Multistage operation X5-03 (stage 2, pin 3 / stage 3, pin 2)

In multistage operation, 1 or 2 thermostats can be connected to activate the different burner stages. Multistage operation is possible only when firing on oil.

If neither input «Stage 2» nor input «Stage 3» is active, the burner switches to «Stage 1».

If input «Stage 2» becomes active, the burner switches to the second stage.

If input «Stage 3» becomes active, the burner switches to the third stage. In that case, input «Stage 2» can be active or inactive. The third stage can only be activated with 3-stage operation.

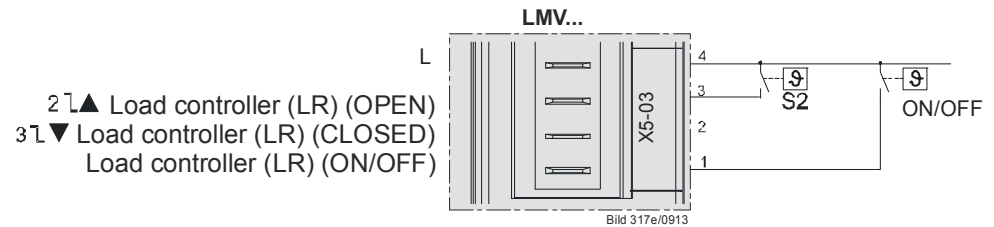

Figure 61: 2-stage operation X5-03

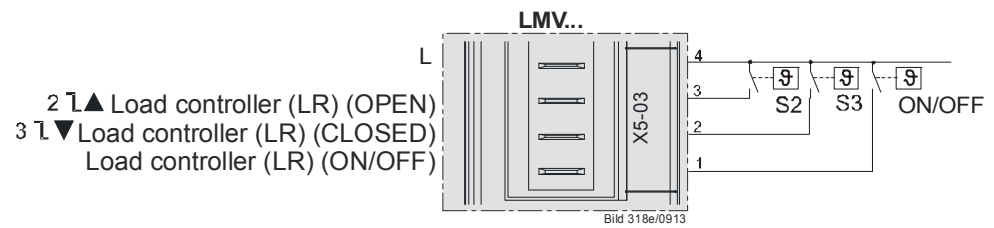

Figure 62: 3-stage operation X5-03

Shifting multistage operation (OPEN pin 3 / CLOSE pin 2)

Using a simple thermostat, a modulating burner can be operated in shifting 2-stage mode. In that case, there must be a firm connection between terminal CLOSE and the live conductor (L), and terminal OPEN must be connected to the thermostat or the controller.

If OPEN is inactive, the active CLOSE terminal drives the burner to low-fire.

If OPEN becomes active, priority is given over terminal CLOSE so that the output is increased by driving the burner to high-fire.

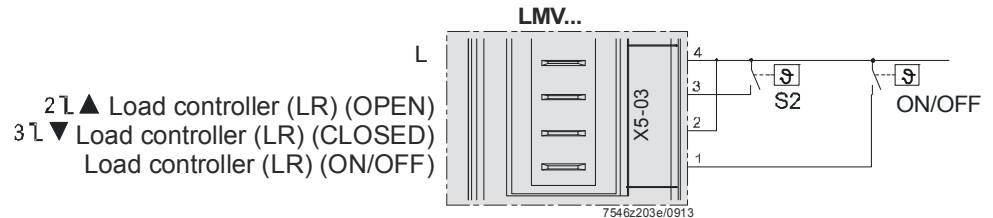

Figure 63: Shifting multistage operation (OPEN pin 3 / CLOSE pin 2)

Parameter 205 is needed to interchange usage of the load controller contacts for multistage operation. In that case, the burner switches to the third stage when input Stage 2 is active (load controller OPEN). This has no impact on modulating operation.

No.	Parameter
205	Function <i>Load controller contacts</i> 0 = standard 1 = stages interchanged

Modulating		Standard	Stages interchanged
X5-03 pin 1	ON / OFF	Low-fire	Low-fire
X5-03 pin 2	Close	Signal Close	Signal Close
X5-03 pin 3	Open	Signal Open	Signal Open

2-stage		Standard	Stages interchanged
X5-03 pin 1	ON / OFF	Stage 1	Stage 1
X5-03 pin 2	Close	Stage 2	Stage 1
X5-03 pin 3	Open	Stage 2	Stage 2

3-stage		Standard	Stages interchanged
X5-03 pin 1	ON / OFF	Stage 1	Stage 1
X5-03 pin 2	Close	Stage 3	Stage 2
X5-03 pin 3	Open	Stage 2	Stage 3

9.3 Default output via building automation – X92

To control the LMV37.4... basic unit, building automation can predefine an output via a bus system. Building automation is connected to the basic unit via the X92 interface. Burner startup can take place only when contact X5-03 pin 1 is closed (load controller (LR) ON / OFF).

For more detailed information about the connection of building automation, refer to chapter *Connection to superposed systems* in this document and to the *Modbus User Documentation (A7541)*.

Minimum positioning step

To avoid unnecessary positioning steps of the actuators when the predefined target output varies, a minimum positioning step can be set. The basic unit changes the output only if the change in target output exceeds the minimum positioning step. The minimum positioning step only becomes active in modulating operation.

No.	Parameter
123.0	Minimum output positioning step: Output building automation

Behavior in the event the building automation and control system fails

If the system receives no more data from building automation, it delivers the output set with parameter 148. The time that elapses until communication breakdown is detected can be set via parameter 142.

No.	Parameter
142	Setback time in the event of communication breakdown Setting values 0 = deactivate 1...7200 s
148	Default output if communication with building automation is interrupted Setting values: For modulating operation , the setting range is as follows: 0...19.9 = burner OFF 20...100 = 20...100% burner rating For multistage operation , the following settings apply: 0 = burner OFF, P1, P2, P3 Invalid = no default output predefined by building automation Default setting: <i>Invalid</i>

Setting choices:

- a) Set default output via parameter 148 to undefined (--)
In the event communication breaks down, the last valid preselected output is maintained. The next load controller activated in accordance with the priority (refer to chapter *Prioritization of load sources*) ensures control from this output position.
- b) Set default output via parameter 148 to 0, 20...100% or multistage
If communication breaks down, the output requested by building automation becomes invalid and the output set via parameter 148 is delivered.



Note

In that case, outputs via load controllers having a priority lower than building automation cannot be delivered.

9.4 Manual output

A manual output can be set with the «Normal display» of the display and operating unit or via the PC software.

Manual output via the display and operating unit

Manual output can be activated or adjusted by pressing the **F** button for at least 1 second and by pressing the **+** or **-** button.

Output **0** means *Manually OFF*.

As long as the manual output is active, the output appearing on the normal display flashes.

To deactivate and to change to automatic operation, press **ESC** for 3 seconds.

If *Manually OFF* is activated, it is stored via mains OFF.

On power return, the burner assumes the *Manually OFF* position (**OFF** flashing) (refer to chapter *Operation*).

Activation of *Manually OFF* in operation

To activate *Manually OFF*, first run the system to the minimum output limit. Then, press the **F** button for at least 1 second and press the **-** button.

Manually OFF is activated by releasing and pressing again the **F** button and pressing the **-** button.



Caution!

***Manually OFF* must not be used just to put a burner out of operation when doing mounting work, or when the burner is not ready for operation. The safety notes contained in chapter *Safety notes* must be observed!**

Manual output via the PC software

Refer to description of the PC software, Software Document J7352.

9.5 Output with curve settings

To set the curves via the display and operating unit or the PC software, a special parameterization output is provided. Using this output, it is also possible to approach the point of ignition. The output is delivered automatically and cannot be set manually. It is only mentioned here for the sake of completeness.

9.6 External load controller via analog input X64 pin 1 / X64 pin 2

For the preselection of external outputs, an analog 4...20 mA input is provided. Burner startup can take place only when contact X5-03 pin 1 is closed (load controller (LR) On / Off).

Switching thresholds / minimum positioning step

A disruption of the current input or a current signal <3 mA leads to deactivation of the analog input's external predefined output. To avoid unnecessary positioning steps of the actuators when the input signal varies, it is possible to set a minimum positioning step for the predefined output. The minimum positioning step only becomes active in modulating operation. For the external load controller via the analog input, a value of 1% is preset.

No.	Parameter
123.1	Minimum output positioning step: Output external load controller analog

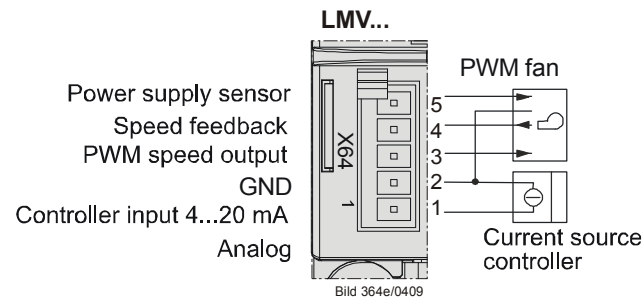

Figure 64: External load controller via analog input X64 pin 1 / X64 pin 2

9.6.1 Switching thresholds for modulating operation

Actual value	Current	Display / output value
Low-fire	3...4 mA	20%
Low-fire	4 mA	20%
High-fire	20 mA	100%

9.6.2 Switching thresholds for multistage operation

For multistage operation, a hysteresis band about the thresholds is introduced. This hysteresis band replaces the minimum positioning step used in multistage operation. The band width is approx. 1 mA.

2-stage operation

Actual value	Current	Display / output value
Stage 1	5 mA (3...12 mA)	P1
Hysteresis band	12...13 mA	---
Stage 2	15 mA (13...20 mA)	P2

3-stage operation

Actual value	Current	Display / output value
Stage 1	5 mA (3...7 mA)	P1
Hysteresis band 1	7...8 mA	---
Stage 2	10 mA (8...12 mA)	P2
Hysteresis band 2	12...13 mA	---
Stage 3	15 mA (13...20 mA)	P3

9.7 Prioritization of load sources

To simplify the system's configuration, the load source must be selected. The system automatically detects the available load sources and selects them. If several load sources are connected, they are selected according to the following priorities:

Parameter 942	Priority	Active load source
	1 highest	Chapter <i>Controller-ON contact X5-03, pin 1</i> When the input is activated, the other load sources are assessed according to their priorities. When the input is deactivated, the burner is OFF
1	2	Chapter <i>Output with curve settings</i>
2	3	Chapter <i>Manual output</i>
3	4	Chapter <i>Load controller via building automation X92</i>
4	5	Chapter <i>External load controller via analog input X64 pin 1/pin 2</i>
5	6 lowest	Chapter <i>External load controller via contacts X5-03, pin 2/pin 3</i>



Note!

When the *Switching back to pilot* function is used, the load controller inputs OPEN CLOSE (X5-03 pin 2 and 3) are not available (refer to chapter *Switching back to pilot*). Analog input X64 is used as the power source in this case.

The active load source can be read out via parameter 942.

9.7.1 Emergency operation with several load controllers

By making use of the prioritization described above, it is also possible to implement emergency operation. Should the building automation and control system fail (provided parameter 148 is set to undefined (--)), the unit switches automatically over to the external load controller.

A load controller can be connected via analog input or – if existing – via contacts.

9.7.2 Manual control

If the external load controller via analog input or contacts is not used, a simple manual output adjustment via switch can be implemented by cutting the connection to the load controller for switching from automatic to manual operation. In that case, the system switches to the external load controller via contact. A switch for Open/Close or stage 2/stage 3 can then be connected to the load controller's terminals.

10 Electronic air-fuel ratio control

10.1 General

Electronic air-fuel ratio control is used to control the burner's actuators depending on burner output. It is possible to connect 2 actuators and, optionally, 1 VSD. Resolution is 0.1° with the actuators and 0.1% with the VSD. Output can be regulated in increments of 0.1% in modulating mode and with a maximum of 3 stages in multistage mode.

To reduce the electric power required for the actuators, they are never operated simultaneously, but in successive order, or alternately.

10.2 Behavior outside the operating positions

Outside their operating positions, the actuators approach the different positions in successive order.

The program phase determines the position to be approached.

10.2.1 Traveling speed

The running speed of the actuators is fixed at 5 seconds for a positioning angle of 90° for SQM33.4, SQM33.5, and SQN1.

The speed is 10 seconds for a positioning angle of 90° for SQM33.6.

The SQM33.7 requires 17 seconds for a positioning angle of 90°.

The ramp speed of the VSD can be adjusted separately for higher and lower speeds.

No.	Parameter
522	Ramp up
523	Ramp down

The setting also applies to the operating position (refer to chapter *Operating position*).

10.2.2 Home position

This position is approached in the *Home run* (10), *Standby* (12) and *Lockout position* (00) phases.

The position can be set via the following parameters:

Parameter	Actuator
501.00	Home position fuel actuator
502.00	Home position air actuator
503.00	No-load speed VSD

10.2.3 Prepurging

This position is approached in phase *Traveling to prepurging* (24).

The position can be set via the following parameters:

Parameter	Actuator
501.01	Prepurge position fuel actuator
502.01	Prepurge position air actuator
503.01	Prepurge speed VSD

No.	Parameter
222	Gas: Prepurging 0 = inactive 1 = active
262	Oil: Prepurging 0 = inactive 1 = active

10.2.4 Ignition

The ignition position is approached in phase *Traveling to the ignition position* (38).

The position is set via curve parameterization under **P0**. In modulating operation, this point is assigned to an output of 10%.

10.2.5 Postpurging

This position is approached in phase *Traveling to postpurging* (72).

The position can be set via the following parameters:

Parameter	Actuator
501.02	Postpurge position fuel actuator
502.02	Postpurge position air actuator
503.02	Postpurge speed VSD

10.3 Modulating operation

In modulating mode, it is possible to operate 2 actuators and 1 VSD. The burner's output can be regulated between 20% (low-fire) and 100% (high-fire) in increments of 0.1%. Since the actuators are never allowed to operate simultaneously, the output is increased in small steps of 1%. In the case of an operating ramp of 20% after 100% in 32 seconds, this represents 1 step in 400 ms. Within such an output step, the air actuator is operated in the first 200 ms, and the VSD and fuel actuator in the second 200 ms.

10.3.1 Definition of curves

The air-fuel ratio curves are defined by 10 curvepoints that are fixed and distributed across the output range.

The following assignment applies:

Curvepoint	Output	Meaning
P0	10%	Point of ignition, not approached in the operating position
P1	20%	Low-fire
P2	30%	
P3	40%	
P4	50%	
P5	60%	
P6	70%	
P7	80%	
P8	90%	
P9	100%	high-fire

The actuator positions can be set with a resolution of 0.1°.

Between the curvepoints, the positions are interpolated in a linear manner.

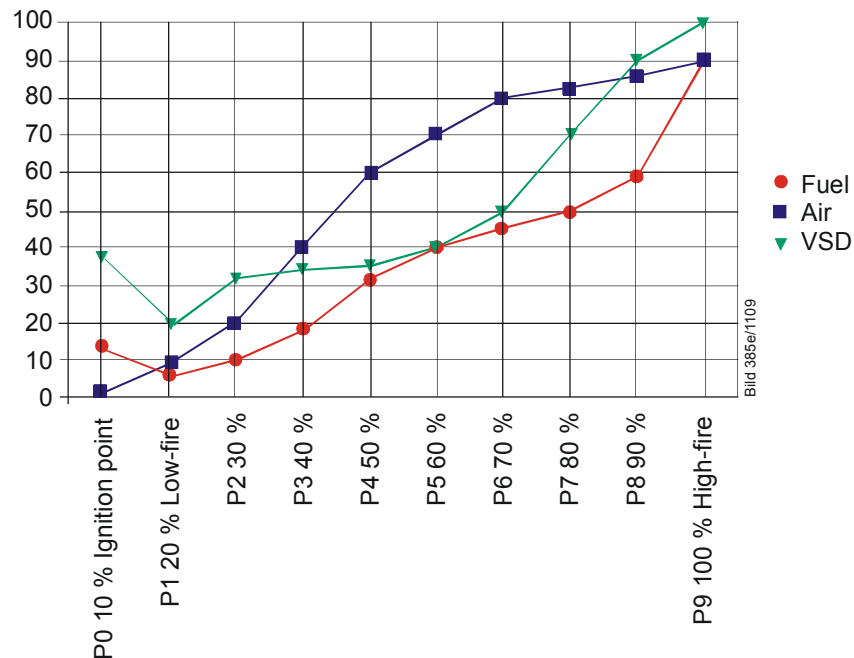

Figure 65: Definition of curves

No.	Parameter
401	Ratio control curves fuel actuator (only curve setting)
402	Ratio control curves air actuator (only curve setting)
403	Ratio control curves VSD (only curve setting)

10.3.2 Traveling speed / maximum curve slope

The time required to modulate from low-fire to high-fire can be set via parameter 544.

In connection with the actuator's ramp in the basic unit, the following maximum positioning angles or speed changes between 2 curvepoints can be covered:

Type of actuator	Positioning speed	Modulation	Modulation	Modulation	Modulation
		32 s	48 s	64 s	80 s
		Positioning angle ²⁾	Positioning angle ²⁾	Positioning angle ²⁾	Positioning angle ²⁾
Actuators (3 Nm)	5 s / 90°	31°	46°	62°	77°
Actuator SQM33.6	10 s / 90°	15°	22°	30°	37°
Actuator SQM33.7	17 s / 90°	9° ¹⁾	13°	18°	22°
VSD	5 s / 100%	40 %	60 %	80 %	100 %
	10 s / 100%	20 %	30 %	40 %	50 %
	20 s / 100%	10 %	15 %	20 %	25 %
	30 s / 100%	6,6 % ¹⁾	10 %	13 %	16 %
	40 s / 100%	5 % ¹⁾	7.5 % ¹⁾	10 %	12 %

¹⁾ Depending on the setting, restricting the maximum positioning angle or the maximum speed differential does not allow the maximum position of 90° or 100% to be reached.

²⁾ Maximum difference between 2 curve points

No.	Parameter
522	Ramp up
523	Ramp down
544	Ramp modulating

The setting also acts outside the operating position (refer to chapter *Traveling speed*).

VSD

Between the ignition time (P0) and the low-fire point (P1), a speed differential of up to 40% can be set for the VSD, independent of the selected ramp. This means that the period of time from ignition to low-fire can vary between 4...32 s (5...40 s ramp).

Error code	Diagnostic code	Meaning for the LMV37.4... system
84	Bit 0 Valency 1	VSD: Curve too steep in terms of ramp rate
	Bit 1 Valency 2..3	Fuel actuator: Curve too steep in terms of ramp speed
	Bit 2 Valency 4..7	Air actuator: Curve too steep in terms of ramp speed

10.3.3 Entering the running position

The burner is ignited when ignition position **P0** is reached. When entering operating phase **60**, the actuators follow the defined curves until the low-fire position is reached (20% or parameter 545).

10.3.4 Operating position

As demanded by the load controller, the actuators are driven along the defined 20% and 100% curves. Point of ignition **P0** can only be reached via the curve settings.

10.3.5 Limitation of modulation range

If the modulation range shall be further restricted from 20 to 100% against the defined curve, 2 parameters are available to define a new low-fire and high-fire position.

No.	Parameter
545	Lower output limit undefined = 20 %
546	Upper output limit undefined = 100 %

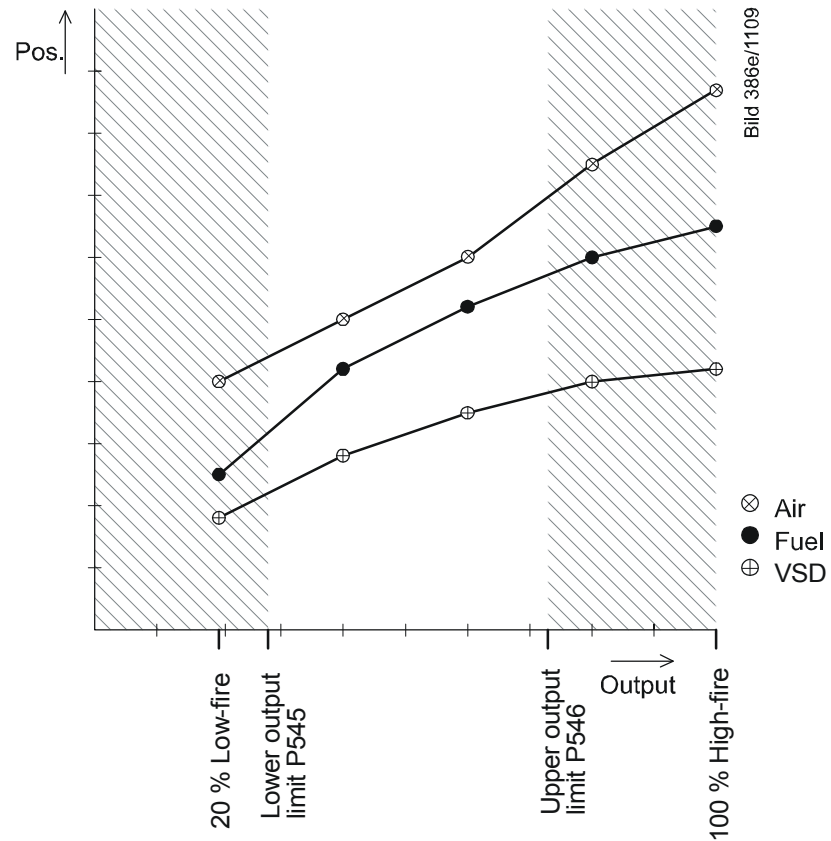

Figure 66: Restriction of modulation range

10.3.6 Setting the minimum and maximum output

When changing the setting of minimum and maximum output after making the curve settings, following is to be observed:

After leaving the curve settings with completely defined curvepoints, proceed in modulating operation by setting the minimum / maximum output (parameter 546).

In the case of warm settings, the parameterized output remains active until the minimum / maximum output setting is completed. Any change of the minimum / maximum output is adopted by the parameterized output. Automatic operation becomes active only after leaving the minimum / maximum output.

This procedure ensures that the system maintains the output set by the user, thus facilitating **troublefree** setting of the minimum / maximum output.

Benefits:

- The current output always corresponds to the minimum / maximum output presently parameterized, or to the system output of the curve settings made last, which means that the output can be ascertained accurately and free from interference
- The load sources of low priority (contacts, analog input, building automation output, manual output) are deactivated
- During the curve and the subsequent minimum/maximum output settings, the *Manual OFF* function is deactivated
- Unambiguous and easy-to-understand behavior of the system



Note

If there is no need to limit the output, it is not necessary to set the minimum / maximum output. In that case, the undefined minimum / maximum output corresponds to a minimum output of 20% and a maximum output of 100%.

10.4 Multistage operation

This operating mode is only available when firing on oil. There is a choice of 2-stage and 3-stage operation. Hence, the burner's output can be modulated via 2 or 3 stages. Modulation is accomplished by adjustment of the air actuator or the VSD and by switching the fuel valves for adjusting the amount of fuel.

10.4.1 Definition of curves

Air-fuel ratio control is defined via the 2 or 3 static output points. To switch the valves on and off, switch-on and switch-off points must be defined.

The following assignments apply:

Curve-point	Meaning	Valve
P0	Point of ignition (not approached in the operating position)	V1
P1	Stage 1	V1
P2on	Switch-on point stage 2. When the angle exceeds this point, the fuel valve for the second stage is switched on	V1
P2_d	Presetting of point P2 with no approach	V1
P2	Stage 2	V2
P2of	Switch-off point stage 2. When the angle falls below this point, the fuel valve for the second stage is switched off	V2
P3on	Switch-on point stage 3. When the angle exceeds this point, the fuel valve for the third stage is switched on	V2
P3_d	Presetting of point P3 with no approach	V2
P3	Stage 3	V3
P3of	Switch-off point stage 3. When the angle falls below this point, the fuel valve for the third stage is switched off	V3

The actuator positions can be set with a resolution of 0.1°, the speeds with a resolution of 0.1%.

10.4.2 Traveling speed

The air actuator or the VSD is operated like outside the operating position. The defined ramp speeds are used.

The speed of the VSD can be adjusted separately for speed increase or decrease.

No.	Parameter
522	Ramp up
523	Ramp down

The setting also acts outside the operating position.

The running speed of the actuators is fixed at 5 seconds for a positioning angle of 90° for SQM33.4, SQM33.5, and SQN1.

The speed is 10 seconds for a positioning angle of 90° for SQM33.6.

The SQM33.7 requires 17 seconds for a positioning angle of 90°.

10.4.3 Adjustment of output

When the output increases, the system moves from the curvepoint of stage 1 (P1) to the switch-on point of stage 2 (P2on). If the switch-on point is exceeded, the valve for the second stage is switched on. Then, the system moves to the curvepoint for stage 2 (P2). When the output decreases, the system moves from the curvepoint of stage 2 (P2) to the switch-off point of stage 2 (P2of). If this point is crossed, the valve for the second stage is switched off. Then, the system moves to the curvepoint for stage 1 (P1). In 3-stage operation, the output between stage 2 and stage 3 is adjusted analogously to 2-stage operation. As static outputs, only **P1**, **P2** and **P3** can be approached. The switch-on and switch-off points are crossed only when changing between stages. The traveling speeds are fixed. Depending on the positioning angles to be covered, air actuator and VSD do not reach the operating or switch-on/switch-off points at the same time. The valves are switched on/off only after both actuators have reached their correct positions.

When parameterizing the curves, the switch-on points can also be approached in a stationary manner. In addition, when setting the curve via $P2_d$ ($P3_d$), curvepoint $P2$ ($P3$) can be readjusted without traveling to it. In that case, the system is at the respective switch-on point. This procedure is used to reduce the operating time if there is shortage of air.

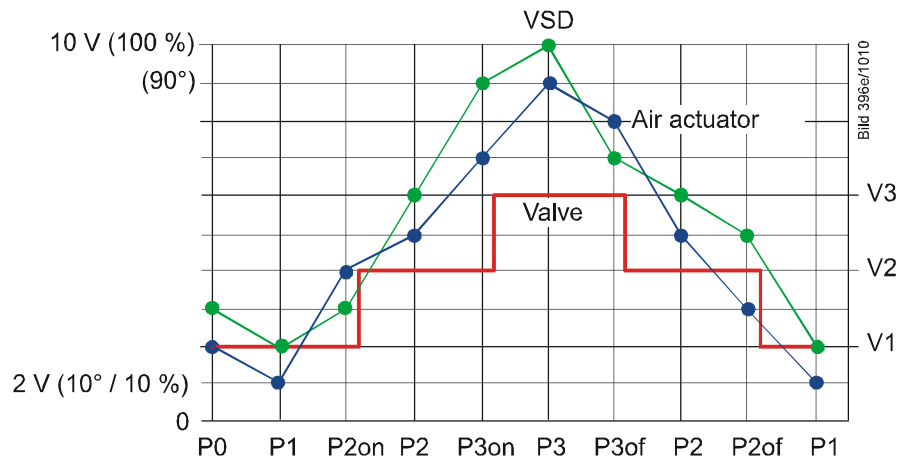

Figure 67: Adjustment of output

10.4.4 Entering the operating position

The burner is ignited at ignition position **P0**. When entering operating phase **60**, the actuators are driven from ignition position **P0** to the operating point of stage 1 (P1) at the respective traveling speed.

10.4.5 Operating position

In the operating position, the burner's output can be adjusted between operating points **P1** and **P2** or **P3** in accordance with the load controller's presetting, as described in chapter *Adjustment of output*. Ignition position **P0** is not approached anymore. It can only be reached via curve adjustment.

10.4.6 Limitation of modulation range

If the modulation range for stage 1 and stage 2, or stage 3, shall be further restricted, 2 parameters can be used to define a new low-fire and high-fire position.

No.	Parameter
545	Lower output limit undefined = 20 %
546	Upper output limit undefined = 100 %

10.5 End of operating position

When there is no more heat request, the system switches to phase 62. Here, the burner runs down to low-fire as long as possible before the valves are shut.

The available period of time can be set via parameter 212. If this time is set to the minimum value, the burner is immediately shut down if there are no more requests for heat. If the time exceeds 32 seconds, the burner always runs to low-fire. Naturally, it is also possible to set intermediate times.

No.	Parameter
212	Max. time down to low-fire

10.6 Notes on settings and parameter settings

- When making the settings for the electronic air-fuel ratio control system integrated in the LMV37.4..., it must be ensured that sufficient amounts of excess air are available because over a period of time, the flue gas values are impacted by a number of factors, such as air density, wear of actuators and controlling elements, etc. For this reason, the flue gas values initially set must be checked at regular intervals
- To safeguard against accidental or unauthorized transfer of parameters from the parameter backup of the ACS410 to the LMV37.4... basic unit, the OEM (burner or boiler manufacturer) must enter an **individual burner identification** for every burner. Only when this requirement is satisfied does the LMV37.4... system make certain that the ACS410 does not transfer a parameter set from a plant (with unsuited and possibly dangerous parameter values) to the LMV37.4... basic unit
- With the LMV37.4..., it should be noted that the unit's characteristics are determined primarily by the parameter settings and not so much by the type of unit. This means that – among other considerations – the parameter settings must always be checked prior to commissioning the plant, and that the LMV37.4... must never be transferred from one plant to another without adapting its parameters to the new plant
- When using the ACS410 PC software, the safety notes given in the relevant Operating Instructions (J7352) must also be observed
- The parameter level is password-protected. The OEM assigns individual passwords to the parameter levels he can access. The unit is supplied with default passwords entered by Siemens; they must be changed by the OEM. These passwords are confidential and may be assigned to authorized personnel only
- Confidential and may only be assigned to authorized staff
- The responsibility for setting parameters is assumed by the person who, in accordance with the access rights, has made changes on the respective setting level

In particular, the OEM assumes responsibility for the correct parameter settings in compliance with the standards covering the specific applications (e.g. EN 676, EN 267, EN 1643, etc.).

11 Actuators X53 / X54

One or 2 actuators can be connected to the LMV37.4... system, depending on the selected operating mode (refer to chapter *Selection of operating mode*).



Caution!

When mounting the actuators, it must be made certain that the mechanical link to the controlling elements is rigid!

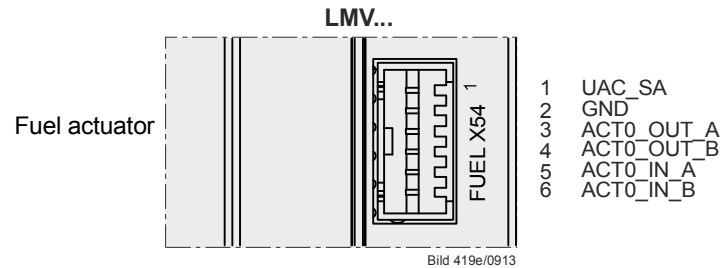

Figure 68: Fuel actuator (X54)

The actuators are suited for direct connection to the LMV37.4...

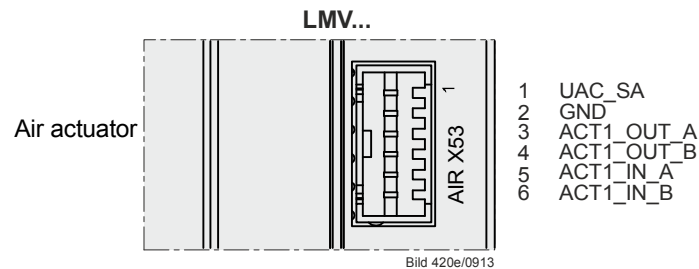

Figure 69: Air actuator (X53)

11.1 Function principle

The actuators are driven by stepper motors. The resolution reached when making 1 positioning step is 0.1°.

The running speed of the actuators is fixed at 5 seconds for a positioning angle of 90° for SQM33.4, SQM33.5, and SQN1.

The speed is 10 seconds for a positioning angle of 90° for SQM33.6.

The SQM33.7 requires 17 seconds for a positioning angle of 90°. An optical incremental transducer is used to monitor the current position. Due to the use of a gear train with almost no backlash, position control is not required.

11.2 Definition of angles

The angles and angular ranges are specified in the Data Sheets of the relevant actuators.

SQM33...: Refer to Data Sheet N7813

SQN1...: Refer to Data Sheet N7803

Also refer to figure *Angle definitions with SQM33...*

11.3 Referencing

An incremental transducer is used for position feedback. This means that referencing of the actuators must be performed after power-ON. In addition, at the end of each shutdown in phase 10, the actuators are referenced to ensure that individual stepping errors, which could lead to shutdown, do not accumulate. If a position error occurs, the system switches to the safety phase (phase 01), enabling the actuators with detected position errors to be referenced. During the following phase 10, the only actuators referenced are those that were not referenced before in the safety phase (phase 01). The position of the reference point can be selected depending on the type of burner, either the *Closed* position ($<0^\circ$) or the *Open* position ($>90^\circ$).

When using actuators SQM33.6 or SQM33.7, the actuator type (parameter 613) must be set (refer to chapter *Actuator type / running time*).



Note!

If a SQM33.7 is used, the modulating operating ramp (parameter 544) may need to be increased (refer to chapter *Running speed / maximum curve slope*).

No.	Parameter
601	Selection of reference point Index 0 = fuel Index 1 = air 0 = close ($<0^\circ$) 1 = open ($>90^\circ$)
602	Direction of rotation of actuator Index 0 = fuel Index 1 = air 0 = counterclockwise 1 = clockwise (exclusively for SQM3...)
603	Tolerance limit of position monitoring (0.1°) Index 0 = fuel Index 1 = air Greatest position error where an error is securely detected → Error detection band: (parameter 606 – 0.6°) up to parameter 606
611	Type of referencing Index 0 = fuel Index 1 = air 0 = standard 1 = stop within the usable range 2 = internal stop 3 = both
613	Type of actuator Index 0 = fuel Index 1 = air 0 = 5 s / 90° (SQN13... / SQN14..., SQM33.4, SQM33.5) 1 = 10 s / 90° (SQM33.6) 2 = 17 s / 90° (SQM33.7)



Application note!

Single-sided load torque is recommended due to the type of gear train for the SQM33.6 / SQM33.7 actuators. In the event of load on both sides, a backlash of $\pm 0.3^\circ$ must also be considered in addition to plant design or setting

11.3.1 Reference travel

Reference travel means that different reference travels are performed, aimed at unambiguously determining the actuators' permissible working range. This prevents the actuators from traveling to a range outside the optical feedback system or against a mechanical stop should a power failure during referencing occur. Parameter 611 must be set depending on the mechanical construction and the type of actuator used.

In the case of reference travel type 1 and reference point OPEN, the SQM33 actuator first travels to the starting point in the selected direction of rotation.



Note!

Always select reference travel type 2 for SQN13 and SQN14.

Parameterization for reference travel type 0 and type 2

No.	Parameter	Setting for actuator		
		SQM33...	SQN13...	SQN14...
611	Type of referencing			
	Index 0 = Fuel	0	2	2
	Index 1 = Air	0	2	2

Parameterization for reference travel type 1

No.	Parameter	Setting for actuator type...		
		SQM33...		
611	Type of referencing			
	Index 0 = fuel	1		
	Index 1 = air	1		

To prevent the actuator from running against a mechanical stop during referencing, the home position may have to be adjusted (depending on the direction of rotation and a reference point of about 3° or 87°). In the case of stops within the usable range, the prepurge or postpurge position must be checked also.

Refer to the figure below for details of the reference travel.

Example of actuator with counterclockwise rotation:

When referencing in the *Close* position, the actuator first travels a certain distance into the working range (toward the *Open* position). Then, it travels to a position representing maximum -7.7° , thereby crossing the reference mark for the first time. Then, the actuator moves in the other direction again and detects the inner ramp of the reference mark. This is the reference point used by all positions. If the reference point is parameterized in the *Open* position, referencing takes place in a mirror-symmetrical manner. In that case, the actuator first travels into the working range (toward the *Open* position). Then, it crosses the reference mark and travels to a position representing maximum 110.6° , then back to the inner ramp of the reference mark.

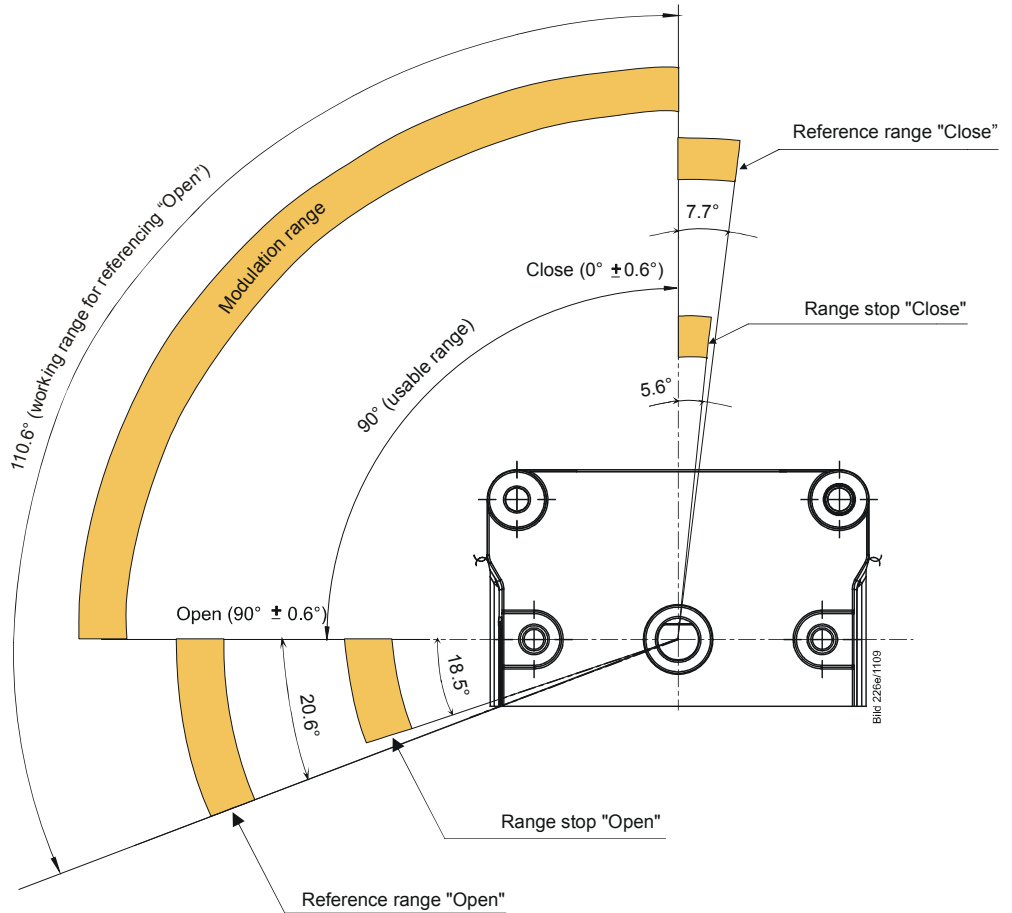

Figure 70: Angle definitions with SQM33...

Error code	Diagnostic code	Meaning for the LMV37.4... system
85	0	Referencing error of fuel actuator
	1	Referencing error of air actuator
	Bit 7 Valency ≥128	Referencing error due to parameter change

11.4 Direction of rotation

With the SQM3... actuator, the direction of rotation can be selected on an individual basis.

No.	Parameter
602.00	Direction of rotation of fuel actuator Index 0 = fuel 0 = counterclockwise 1 = clockwise (exclusively for SQM3...)
602.01	Direction of rotation of air actuator Index 1 = air 0 = counterclockwise 1 = clockwise (exclusively for SQM3...)

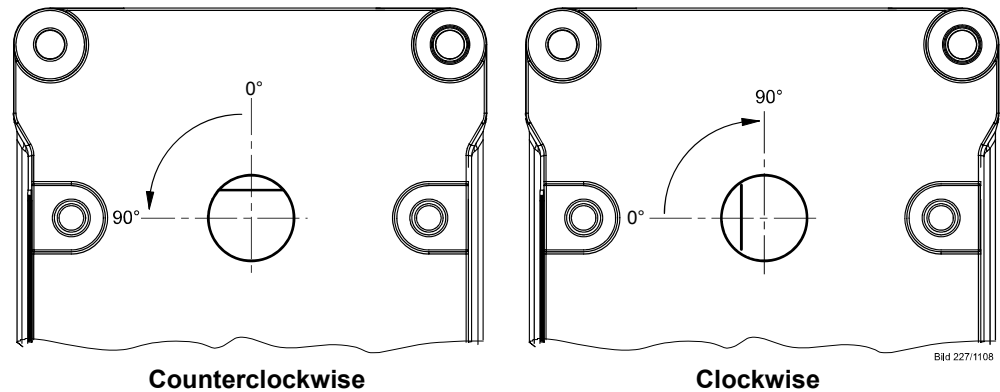

Figure 71: Direction of rotation (example SQM3...)

With the SQN1... actuators, the direction of rotation to be selected is always *Left*.

The direction of rotation of the SQN1... actuators depends on the version:

- SQN13...: Direction of rotation *Left*
- SQN14...: Direction of rotation *Right*



Note

The actuators are always supplied with the flat of the drive shaft facing upward.

11.5 Monitoring the actuator positions

To monitor the actuator's current positions, an optical incremental transducer with a resolution of 0.7° is used. The correct position of the drive shaft is ensured by comparing the motor steps made with the position obtained from the incremental transducer. Due to the different resolutions of motor steps and incremental transducer plus the selected tolerance band, the following error detection band is obtained. The position where – in the error detection band – shutdown takes place depends on the position currently required.

For the default setting made in the factory, the error detection band is as follows:

Smallest position error where an error can be detected	1.1°
Greatest position error where an error is securely detected (default setting parameter 606)	1.7°

The presetting of 1.7° (default setting, parameter 606) is suited for use with actuators type SQN1... and SQM3...



Note

When using SQN1... actuators equipped with plastic gear trains, we recommend to change the preset values as follows:

Product no.	Value
SQN13.14...	1,7°
SQN14.14...	1,7°
SQN13.17...	2,2°
SQN14.17...	2,2°

When referencing under output conditions, the resilience of the actuator's gear train must also be taken into consideration:

Product no.	Resilience at max. rated driving torque
SQM33.41...	0.2°
SQM33.51...	0.2°
SQM33.6	0.2°
SQM33.7	0.2°
SQN13.14...	0.3°
SQN13.17...	0.8°
SQN14.14...	0.3°
SQN14.17...	0.8°

The error detection time is <1 second.



Caution!

This means that – for the design and setting of the burner – a position error resulting from the sum of...

- greatest position error from which an error is detected in all positions,
- resilience at the max. rated torque, and
- mechanical influence from the link between actuator and regulating unit (e.g. coupling)

must not lead to a critical state in terms of safety.

No.	Parameter
606	Tolerance limit of position monitoring (0.1°) Index 0 = fuel Index 1 = air Greatest position error where an error is securely detected → error detection band: (parameter 606 -0.6°) up to parameter 606

Error code	Diagnostic code	Meaning for the LMV37.4... system
86	0	Position error fuel actuator
87	0	Position error air actuator

11.6 Changing the error detection band for monitoring the actuator positions

The error detection band can be changed via parameter 606. A change is to be made only when using SQN13.17... or SQN14.17... actuators which, due to their mechanical design, require greater tolerances.

For these types of actuators, set parameter 606 to 2.2°.

No.	Parameter
606	Tolerance limit of position monitoring (0.1°) Index 0 = fuel Index 1 = air Greatest position error where an error is securely detected → Error detection band: (parameter 606 -0.6°) up to parameter 606

11.7 Forced travel

There are errors in the actuators' feedback unit which can only be detected in connection with position changes. To be able to also detect such errors when maintaining the same position for longer periods of time, travel is enforced when – for more than 50 minutes – an actuator moves no more than 2.8°. With forced travel, both actuators are driven 2.8° in the direction of smaller positioning angles and back again to the initial angular position. If a damper is less than 2.8° open, the actuator is driven in the direction of positive angles in order not to run against mechanical stops, if present. Forced travel lasts a total of 1 second.

11.8 Detection of line interruptions

The connecting line ensuring position feedback from the actuator to the basic unit is monitored for interruptions, which means that position feedback cannot fail without being noticed.

Error code	Diagnostic code	Meaning for the LMV37.4... system
86	Bit 0 Valency 1	Line interruption fuel actuator
87	Bit 0 Valency 1	Line interruption air actuator

11.9 Protection against actuator mixup

Mixup of actuators can be detected through appropriate mounting (using different reference marks for the air and fuel actuator: Open/Close/0°/90°). With at least one of the actuators, the reference mark not used must be blocked by a mechanical stop. Now, if the actuator connections with the basic unit have been interchanged, one of the actuators cannot reach the reference mark, which is detected by the basic unit. Protection against mixup is a question of burner application and must be ensured by the OEM.



Caution!

To be able to detect mixup of actuators, the burner manufacturers must ensure that the 2 actuators use opposing reference points. One of the actuators uses the OPEN reference, the other the CLOSED reference. Approach of the reference point not used must be blocked with at least one of the actuators!

11.9.1 Proposal for implementation

- Parameterize referencing of the air damper in the CLOSED position
- Parameterize referencing of the fuel damper in the OPEN position. Unnecessary travel can be avoided by defining a home position of **90°** for the fuel damper
- Mechanical stop at the air damper in the range between 90° and 108.5°, and / or mechanical stop at the fuel damper in the range between 0° and -5.6°

Referencing process

- From any position in the working range (0...90°), but typically from the home position, the air damper travels to the **-7.7°** position and back again to the home position
- From any position in the working range (0...90°), but typically from the home position, the fuel damper travels to the **110.6°** position and back again to the home position

Process in the event of mixup

- The fuel damper (fitted in place of the air damper) travels to the **-7.7°** position and back again to the home position
- The air damper (fitted in place of the gas damper) tries to travel to the **110.6°** position, but is prevented from doing so by the mechanical stop. This is unsuccessful travel and identified as mixup

12 Fan control

12.1 Function principle

Optionally, the LMV37.4... system can be operated with a VSD or PWM fan. Control is accomplished via a DC 0...10 V interface. For control of the fan's speed, a safety-related speed feedback signal is required. With pneumatic air-fuel ratio control, the speed feedback signal is not evaluated. To facilitate the use of fans with different speed ranges, the fan's speed is standardized between 0...100%. Fan control is not connected, a load output and, alternatively, a fuel meter output are available (refer to chapters *Load output X74 pin 3* and *Fuel meter input X75 pin 1/X75 pin 2*).

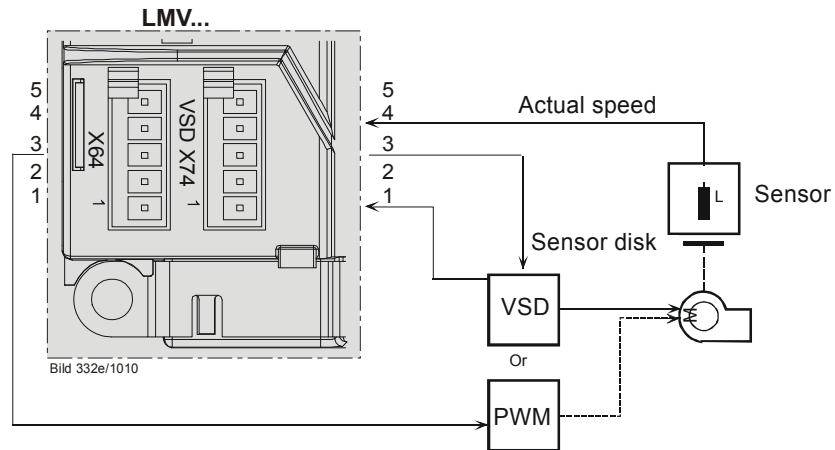

Figure 72: Function principle of VSD

12.2 Activation of VSD/PWM fan

The VSD can be activated in any of the operating modes (parameter 201).

No.	Parameter
542	Activation of VSD / PWM fan 0 = inactive 1 = active



Note

For configuration of the analog output when the VSD is activated, refer to chapter *Power output X74 pin 3!*

12.3 VSD control X74 pin 3

The VSD is controlled via a voltage interface (refer to chapter *Load output X74 pin 3*)!

Depending on the type of VSD used, a release contact is required. This contact can be controlled via the fan motor contactor. To enable the VSD to bring the fan motor's speed to the correct no-load speed, the motor contactor's drop out delay time must be about 25 seconds.

Example:

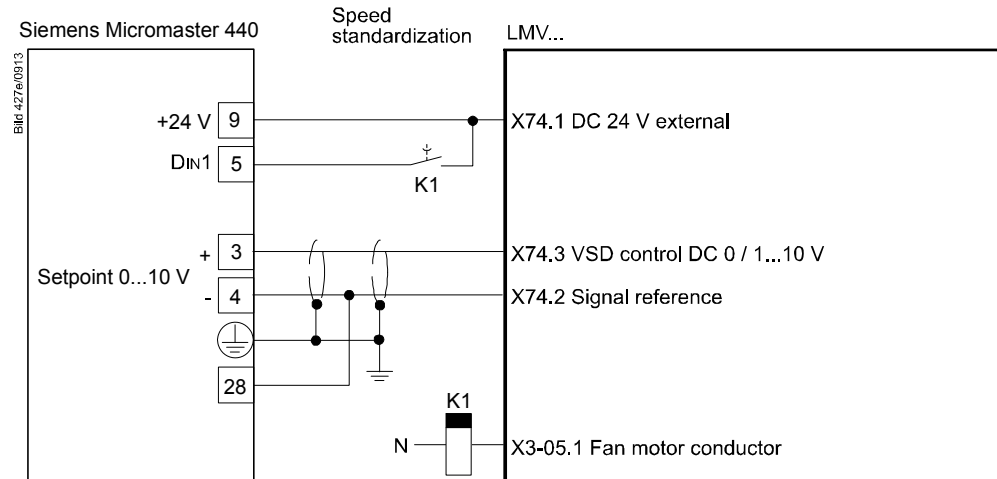

Figure 73: Connection of VSD to the LMV37.4...

It is possible to set the VSD control to 0 via the analog output when the safety loop is open (including burner flange switch).

This may be necessary if the no-load speed is not 0.

No.	Parameter
652	VSD behavior when safety loop / burner flange is open 0 = no VSD control when safety loop / burner flange is open 1 = VSD control independent of safety loop / burner flange

12.4 PWM fan control X64 pin 3

The PWM fan is controlled via PWM voltage interface X64 pin 3.



Caution!

The use of PWM fans is only possible in connection with pneumatic air-fuel ratio control!

12.5 Safe separation of mains voltage and protective extra low-voltage



Caution!

All inputs and outputs of PWM fan control are designed for use with protective extra low-voltage. For this reason, strict separation from the mains voltage side must be ensured!

This necessitates an external power supply by the VSD or an external power pack (X74 pin 1, X74 pin 2).



Note

Power must also be supplied via X74 pin 1 / pin 2 in the case a PWM fan is used.

12.6 Ramp time

The ramp time for fan control can be set separately for acceleration and deceleration (also refer to chapter *Traveling speed/maximum curve slope*).

No.	Parameter
522	Ramp up
523	Ramp down
544	Ramp modulating

If shutdown occurs because the speed has not been reached, the VSD/fan motor might not be able to follow quickly enough the set ramp.

In the case of a ramp time >20 seconds, the modulating operating ramp (parameter 544) must be increased (refer to chapter *Running speed / maximum curve slope*).

Remedy:

Shorten further the ramp of the VSD/fan motor or increase the ramp in the basic unit (parameters 522/523) (also refer to chapter *Traveling speed/maximum curve slope*).

For VSD operation



Caution!

The ramps parameterized for the VSD should be at least 20% shorter than the ramps in the LMV37.4...

Example:

5 s ramp	LMV37.4...	4 s ramp VSD
10 s ramp	LMV37.4...	8 s ramp VSD
20 s ramp	LMV37.4...	16 s ramp VSD
40 s ramp	LMV37.4...	32 s ramp VSD

12.7 Acquisition of speed

12.7.1 Acquisition of speed with proximity switch

The actual speed is acquired by an inductive proximity switch which scans a metal sensor disk. The sensor disk must be attached directly to the motor's drive shaft. Speed acquisition is safety-related. To facilitate the detection of the direction of rotation and to be able to make the plausibility check with only 1 sensor, a sensor disk with angular steps of 60°, 120° and 180° is used. It generates 3 pulse intervals of different length.

Speed acquisition is designed for the connection of different types of sensors.



Caution!

With electronic air-fuel ratio control, speed acquisition is safety-related!

We recommend using the AGG5.310 accessory set.

The absolute speed can be read out via the AZL2...

No.	Parameter
935	Absolute speed

The current speed in standardized form can be read out via the AZL2...

No.	Parameter
936	Standardized speed

Speed input X74 pin 4

Motor speed:	300...6500 rpm
100% speed:	650...6500 rpm
Sensor:	Inductive sensor to DIN 19234 (Namur) or Open Collector (pnp) at $U_{CEsat} < 4\text{ V}$, $U_{CEmin} > DC\ 15\text{ V}$
Power supply:	DC 10 V, max. 15 mA
Switching current:	>10 mA
Cable length:	Max. 3 m (sensor cable must be laid separately!)

Sensor disk

Sensor disk and speed sensor can be ordered as accessory set AGG5.310.

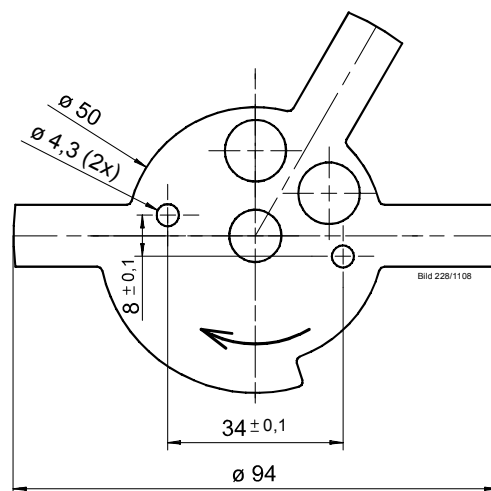

Number of tappets: 3
Angular steps: 60°, 120°, 180°
Accuracy: ±2°

Figure 74: Sensor disk

Speed sensor

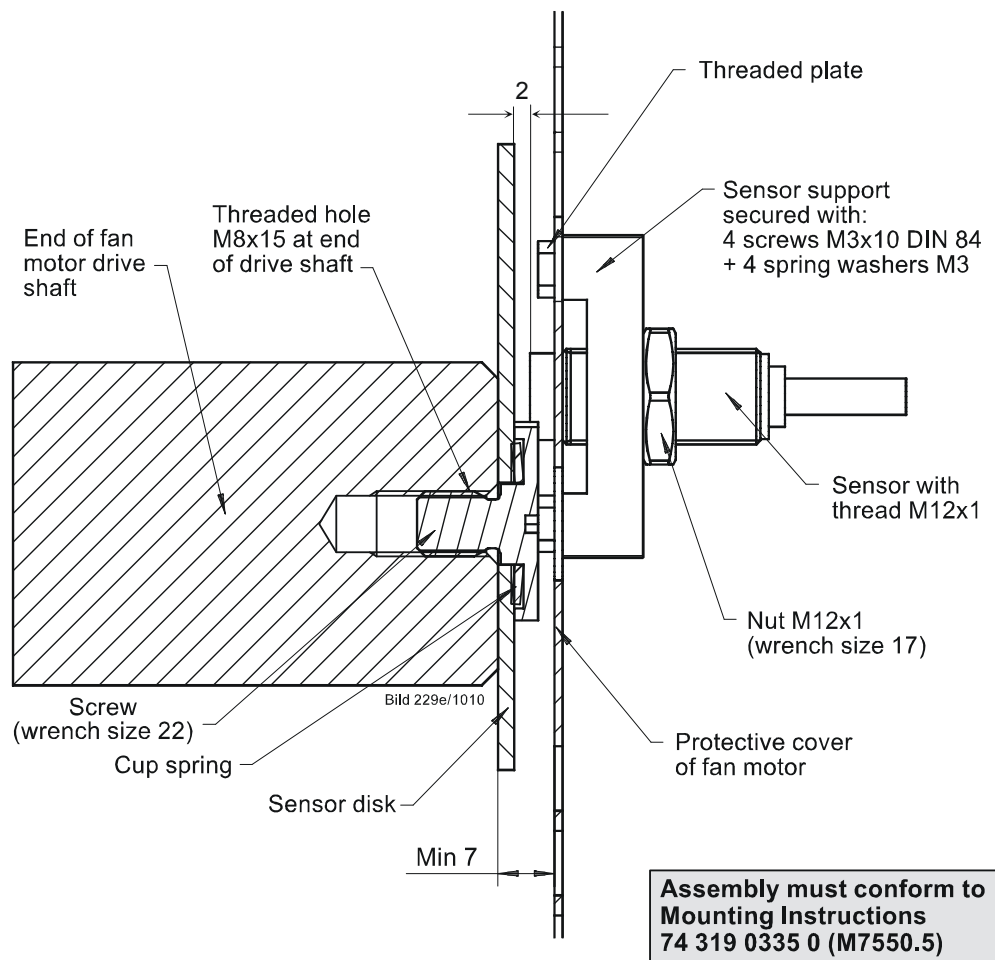

Figure 75: Speed sensor

Selection of fan motor

Motor supplier:

Selection of a motor **with** threaded hole M8 x 15 at the end of the fan motor's drive shaft.

Standard motor and machining (drilling hole and cutting thread M8 x 15).

12.7.2 Acquisition of speed with Hall generator

If the speed is acquired via a Hall generator, the requirements for safety-related applications are the same as those for the speed feedback signal via sensor disk. Required is an asymmetric signal with the 3 pulses of 60°, 120° and 180° for detection of the direction of rotation.

12.8 Speed control

The LMV37.4... controls the fan motor's speed to the setpoint. To ensure that the speed can still be increased when the maximum speed is reached, the speed is standardized when the motor is controlled at 95%. Hence, with a speed setpoint of 100 %, a speed increase of 5 % is still possible.

The control range of the LMV37.4... is +15% / -10%. If this range is not sufficient, error 80 or 83 can occur.

Error code	Diagnostic code	Meaning for the LMV37.4... system
80	1	Control range limitation at the bottom
	2	Control range limitation at the top



Note

Internal control with a VSD or PWM fan motor must not be activated. Otherwise, speed variations can occur, resulting from simultaneous control actions from both the basic unit and internal control.

12.9 Speed supervision

The fan's current speed is acquired by the LMV37.4... and assessed from a safety point of view. If the fan does not operate at the speed setpoint, speed control makes a corrective action, trying to reach the setpoint. If it is not reached within a certain period of time, safety shutdown is initiated. To ensure a high level of availability and safety, a number of monitoring bands with different response times are defined.

It is possible to switch off speed supervision at standstill (no-load speed 0%) in standby mode. This may be necessary if the fan rotates too much in standby mode due to a chimney draft or if an extended ramp time is active with a PWM fan during the transition from the postpurge speed to standstill.

No.	Parameter
653	VSD standstill supervision in standby mode 0 = deactivate 1 = active

Speed deviation in % points	Shutdown time
0...0.5%	Speed reached → no shutdown
0.6...2%	<8 s
2.1...10%	<3 s
>10%	<1 s

Error code	Diagnostic code	Meaning for the LMV37.4... system
83	Bit 0 Valency 1	Lower control range limitation
	Bit 1 Valency 2...3	Upper control range limitation
	Bit 2 Valency 4...7	Interrupt shutdown due to electromagnetic interference
	Bit 3 Valency ≥8	Curve too steep in terms of ramp speed
	Bit 4 Valency ≥16	Interruption of speed signal
	Bit 5 Valency ≥32	Quick shutdown due to excessive speed deviation

12.10 Setting the parameters of VSD

If a control signal of 95% (9.5 V) is not sufficient for the burner to deliver its rated capacity, you can proceed as follows:

- Set the maximum frequency to 105.3% of the motor's rated speed

In the case of a motor frequency of 50 Hz, this means:

Set the maximum frequency of the VSD to $50 \text{ Hz} \times 1.053 = 52.6 \text{ Hz}$ (on the VSD).

- Then, standardize the speed (refer to chapter *Standardization of speed*)

There is no risk of motor overload since only 95% of the maximum control signal is delivered during standardization and – later in operation – the effective speed is controlled and monitored.

Frequencies of between 50 Hz and 52.6 Hz are delivered only if these are needed for reaching the required speed due to increased output.

- Set the ramp times of the VSD according to chapter *Setting the ramp times*

12.11 Standardization of speed

Since the different types of fans operate at different speeds and signal handling should be as straightforward as possible, all speeds in the system are standardized between 0% and 100%. For this reason, the VSD module uses a parameter which contains the *Standard speed* (100% speed). All absolute speeds refer to this speed.

If changes to the VSD or the fan are made, speed standardization should be repeated.



Caution!

- **If automatic speed standardization is activated, or if the standardized speed is changed, the settings of air-fuel ratio control must be checked! Any change of the standardized speed alters the assignment between the percentage values parameterized on the curves and the speed**
- **When the parameter set (refer to ACS410 J7352) is restored, the standardized speed is restored also. In that case, new standardization of speed is required**

Automatic speed standardization

To facilitate determination of the standardized speed, the LMV37.4... features automatic speed standardization. The speed must be standardized while in standby mode. Speed standardization is integrated in the setting process for electronic air-fuel ratio control, but can also be started later from the parameter setting level. When using a release contact for the VSD (external relay at fan output X3-05 pin 1), the fan output is controlled during speed standardization.

1. Start speed standardization

To start automatic speed standardization, set parameter 641 to **1**.

No.	Parameter
641	Control of VSD's speed standardization Error diagnostics of negative values (refer to error 82) 0 = no speed standardization 1 = speed standardization active

2. Drive the air damper to the prepurge position

Speed standardization begins when the air damper travels to the prepurge position. When this position is reached, the air damper should be fully open so that the fan operates at full capacity.

3. Control the VSD

Control the VSD at 95% of the maximum voltage.

A margin of 5% allows the speed to be readjusted should environmental conditions change. This means that full speed (100%) is reached with 95% VSD control (refer to chapter *Setting the parameters of the VSD*).

4. Wait until the speed is higher and has stabilized

Before the 100% speed can be measured, the fan must have reached stationary conditions. This means that the fan must operate under stable conditions above 650 rpm. When this state is reached, a certain waiting time is observed, allowing the speed to eventually stabilize.

5. Measure the speed and store it

When the speed has stabilized, measure and store it as the *Standardized speed* (100% speed).

6. Close the standardization

When standardization is successfully completed, reset parameter 641 to **0**.
If standardization was not successful, parameter 641 assumes a negative value.

The value provides information on the cause of fault:

Value	Error	Remedy
-1	<i>Timeout of standardization (VSD's ramp down time too long)</i>	Timeout at the end of standardization during ramp down of VSD. 1. VSD ramp time settings are not shorter than those of the basic unit (parameter 523).
-2	<i>Storage of standardized speed not successful</i>	Error during storage of standardized speed → lock the basic unit and reset it again, repeat standardization
-3	<i>Line interruption speed sensor</i>	Basic unit receives no pulses from the speed sensor. 1. Motor does not run. 2. Speed sensor is not connected. 3. Speed sensor is not actuated by the sensor disk (check distance).
-4	<i>Speed variation / VSD ramp up time too long / speed below minimum limit for standardization</i>	Motor has not reached a stable speed after ramp up. 1. VSD ramp time settings are not shorter than those of the basic unit (parameters 522, 523). 2. VSD's characteristic is not linear. Configuration of voltage input at the VSD must accord with that of the basic unit (DC 0...10 V). 3. VSD does not follow quickly enough the change of the basic unit. Check VSD settings (input filter, slippage compensation, hiding various speeds). 4. Speed of VSD lies below the minimum for standardization (650 rpm).
-5	<i>Wrong direction of rotation</i>	Motor's direction of rotation is wrong. 1. Motor turns in the wrong direction → change parameterization of the direction of rotation or inter change 2 live conductors. 2. Sensor disk is fitted the wrong way → turn sensor disk.
-6	<i>Unplausible sensor signals</i>	The required pulse pattern (60°, 120°, 180°) has not been correctly identified. 1. Speed sensor does not detect all tappets of the sensor disk → check the distance. 2. As the motor turns, other metal parts are detected also, in addition to the tappets → improve mounting. 3. Electromagnetic interference on the sensor lines → check cable routing, improve EMC.
-7	<i>Invalid standardized speed</i>	Standardized speed measured does not lie in the permissible range → Motor turns too slowly or too fast
-15	<i>Speed deviation $\mu C1 + \mu C2$</i>	The speeds of microcomputer 1 and 2 deviated too much. This can be caused by wrong standardized speeds (e.g. after restoring a data set to a new unit) → repeat standardization and check the fuel-air ratio
-20	<i>Wrong phase of phase manager</i>	Standardization was made in a wrong phase. → Permitted are only phases ≤ 12 → controller OFF, start standardization again.
-21	<i>Safety loop / burner flange open</i>	Safety loop or burner flange is open → repeat standardization with safety loop closed

Value	Error	Remedy
-22	<i>Air actuator not referenced</i>	Air actuator is not referenced or has lost its reference. 1. Check if the reference position can be approached. 2. Check if actuators have been mixed up. 3. If error only occurs after standardization was started, the actuator is possibly overloaded and cannot reach the required position.
-23	<i>VSD deactivated</i>	Standardization was started with VSD deactivated → activate VSD and repeat standardization
-24	<i>No valid operating mode</i>	Standardization was started with no valid operating mode → select a valid operating mode and repeat standardization
-25	<i>Pneumatic air-fuel ratio control</i>	Standardization was started with pneumatic air-fuel ratio control → standardization with pneumatic air-fuel ratio control is not possible

The result of speed standardization (100% speed) can be read out via parameter. The speeds acquired by the 2 microcontrollers can differ by about 1.5%, the reason being slightly different resonator frequencies.

Nr.	Parameter
642.0	Standardized speed of μ C1
642.1	Standardized speed of μ C2

12.12 Control of fan motor with pneumatic air-fuel ratio control

If control of the fan motor is employed for burners with pneumatic air-fuel ratio control, only the control path is used. There is no need to connect a speed feedback signal and to have speed control (for operating modes, refer to chapter *Selection of operating mode*).

12.13 EMC of LMV37.4... and VSD

The function and EMC tests with the LMV37.4... system have been successfully conducted in connection with the following makes and types of VSDs:

Siemens: SED2-0.37 / 22 X
Danfoss: VT2807

During operation, VSDs generate electromagnetic interference on the mains network. For this reason, the supplier's specifications must be strictly observed to ensure that makeup of the system is in compliance with EMC regulations:

Siemens: Operating Instructions → installation conforming to EMC
Danfoss: Technical Brochure → radio suppression filter
Data Sheet on Danfoss EMC filter for long motor cables



Caution!

When using other types of VSD, compliance with EMC regulations and trouble-free operation are not ensured!

12.14 Description of connection terminals

12.14.1 VSD

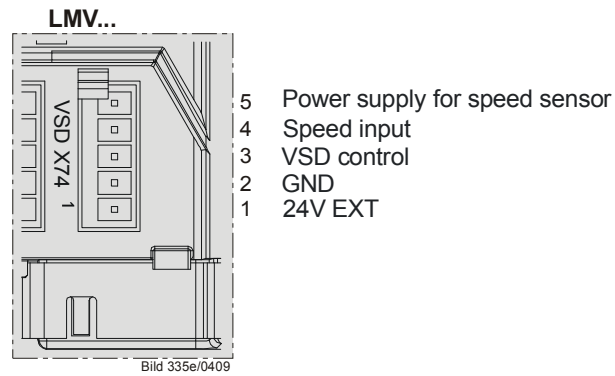

Figure 76: VSD module X74

12.14.2 PWM fan

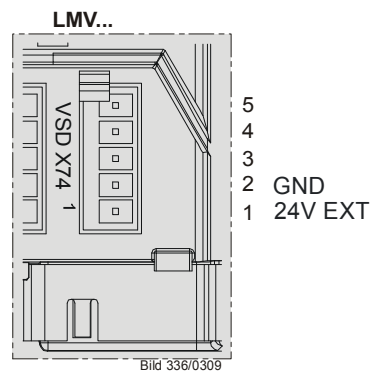

Figure 77: PWM fan X74

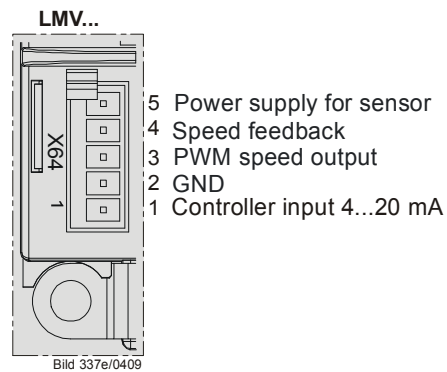

Figure 78: PWM fan X64

13 Load output X74 pin 3

The load output is only available as an alternative to VSD control. If the VSD is deactivated, the output for the VSD delivers the current burner output. The analog output is a voltage output and – using parameter 645 – can be switched between DC 0...10 V, DC 2...10 V and DC 0/2...10 V.

Parameter 645	Voltage range	Remarks
0	DC 0...10 V	No detection of open-circuit
1	DC 2...10 V	Detection of open-circuit possible
2	DC 0/2...10 V	No detection of open-circuit Recommended setting in connection with Micro master VSD



Note

When changing the analog output configuration from DC 0...10 V to DC 2...10 V or DC 0/2...10 V, the voltage values with modulating, 2-stage and 3-stage operation change (refer to chapter *Modulating operation*, chapter *2-stage operation* and chapter *3-stage operation*).

Conversion: New value = (initial value * 0.8) + 2

Example: Initially 2 V → (2 * 0.8) + 2 = 3.6 V
Initially 5 V → (5 * 0.8) + 2 = 6 V

13.1 Safe separation of mains voltage and extra low-voltage



Caution!

The load output is designed for SELV or PELV (refer to chapter *Electrical connection of the LMV37.4...*).

For this reason, strict separation from the mains voltage side must be ensured!

This necessitates power supply by an external power pack (X74 pin 1, X74 pin 2).

13.2 Modulating operation

Actual value	Voltage	Curvepoint	Display / output value
Off	DC 0 V	---	Off
Ignition load	DC 1 V	P0	10%
Low-fire	DC 2 V	P1	20%
High-fire	DC 10 V	P9	100%

The values between low-fire and high-fire are interpolated in a linear manner.

13.3 2-stage operation

Actual value	Voltage	Curvepoint	Display / output value
Off	DC 0 V	---	Off
Stage 1	DC 5 V	P1	P1
Stage 2	DC 10 V	P2	P2

13.4 3-stage operation

Actual value	Voltage	Curvepoint	Display / output value
Off	DC 0 V	---	Off
Stage 1	DC 3 V	P1	P1
Stage 2	DC 5 V	P2	P2
Stage 3	DC 10 V	P3	P3

14 Fuel meter input X75 pin 1 / X75 pin 2

A fuel meter can be connected to acquire the amount of fuel burnt.

The fuel meter function is only available as an alternative to VSD control. If the VSD is deactivated, a fuel meter can be connected to terminals X75 pin 1 and X75 pin 2.

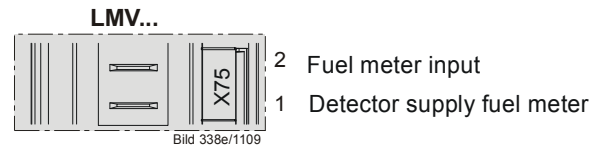

Figure 79: Fuel meter input X75

14.1 Configuration of fuel meter

14.1.1 Types of fuel meters

The LMV37.4... system is designed for use with fuel meters equipped with a Reed contact. Pulse frequency at maximum fuel throughput must be below 300 Hz.

14.1.2 Configuration of pulses per volume unit

Depending on the type of fuel meter used, the number of pulses supplied by it per m^3 or l fuel must be parameterized. A maximum of 400 pulses per volume unit can be preset. The correct amount of fuel is acquired only when this parameter is set.

When the parameter is 0, the fuel meter stops.

No.	Parameter
128	Fuel meter: Pulse valency (pulses / volume unit)

14.1.3 Reading and resetting the meter readings

No.	Parameter
167	Fuel volume resettable (m^3 , l, ft^3 , gal)

The cumulated fuel volume can be read out per parameter. The meter reading can also be reset on the parameter level.

14.2 Fuel throughput

With the fuel meter connected, the system calculates continuously the current fuel throughput. The time required for calculating the fuel throughput varies and lies between 1 and 10 seconds. If the fuel meter delivers no pulses for more than 10 seconds, the display shows **0** fuel throughput. This means that when fuel throughput is at its minimum, the sensor should have a pulse frequency of at least 0.1 Hz. The display is smoothed to improve the settling process. With fuel throughput at its maximum, the maximum frequency is 300 Hz.

14.2.1 Configuration

Calculation of fuel throughput is configured based on the pulse valency of the connected fuel meter.

No.	Parameter
128	Fuel meter: Pulse valency (pulses/volume unit)

When the pulse valency is set to **0.00**, the display shows **0** throughput.

14.2.2 Reading out the fuel throughput

The current fuel throughput can be read out via the following parameter on the service menu:

No.	Parameter
960	Fuel throughput in volume unit /h (m ³ /h, l/h, ft ³ /h, gal/h)

Display of fuel throughput is possible up to 6553 volume units/h.



Note

Display of fuel throughput up to a value of 99.9 on the service menu is made with one decimal place, from 100 with no decimal place.

15 Connection and internal diagram

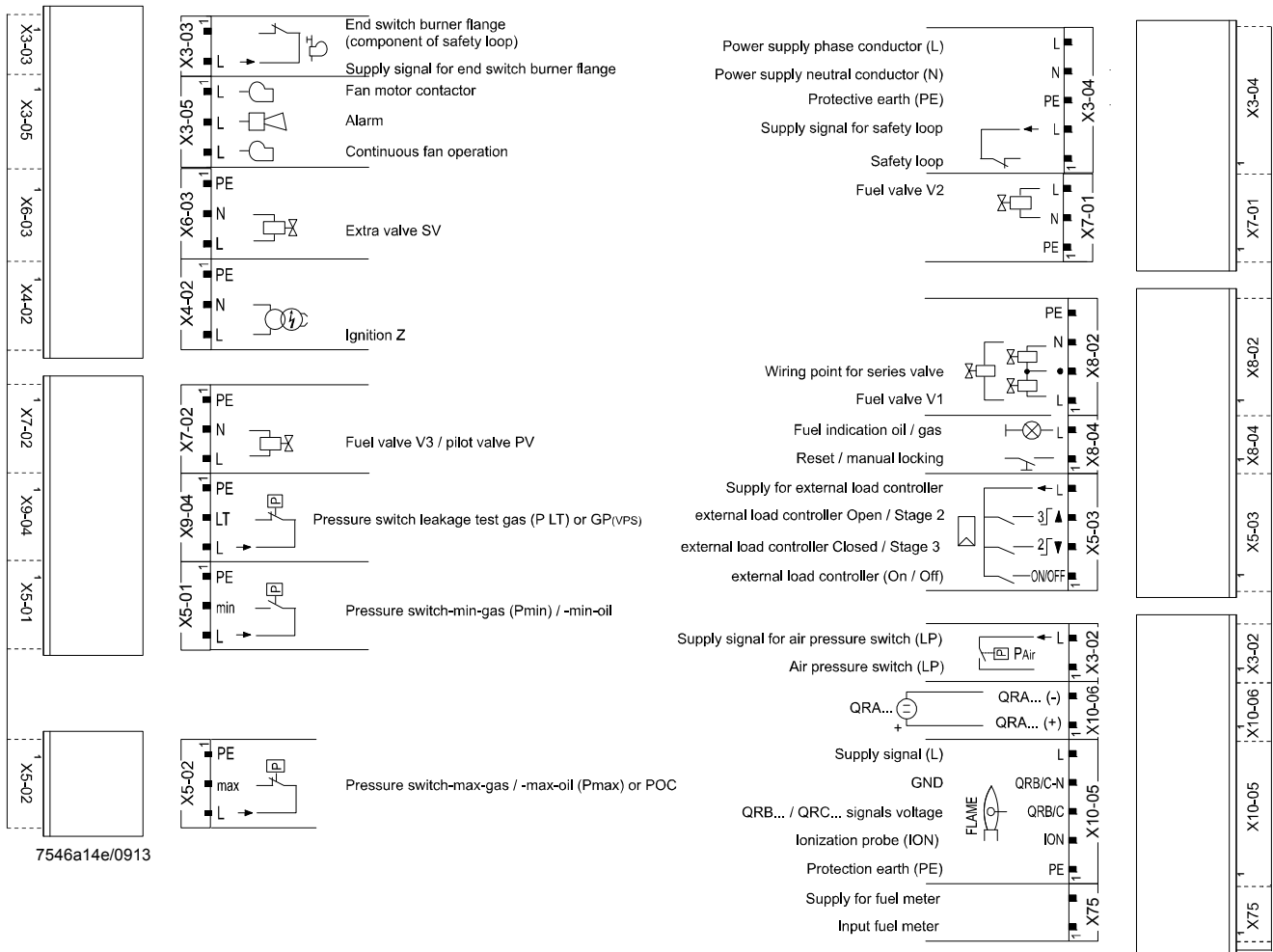

7546a14e/0913

Shielding:

For shielding the cables on the VSD, refer to:

- Siemens *SED2* VSD Commissioning Manual (G5192), chapters 4 and 7, or
- Danfoss Operation Manual *VLT 6000* (MG60A703), chapter *Installation*

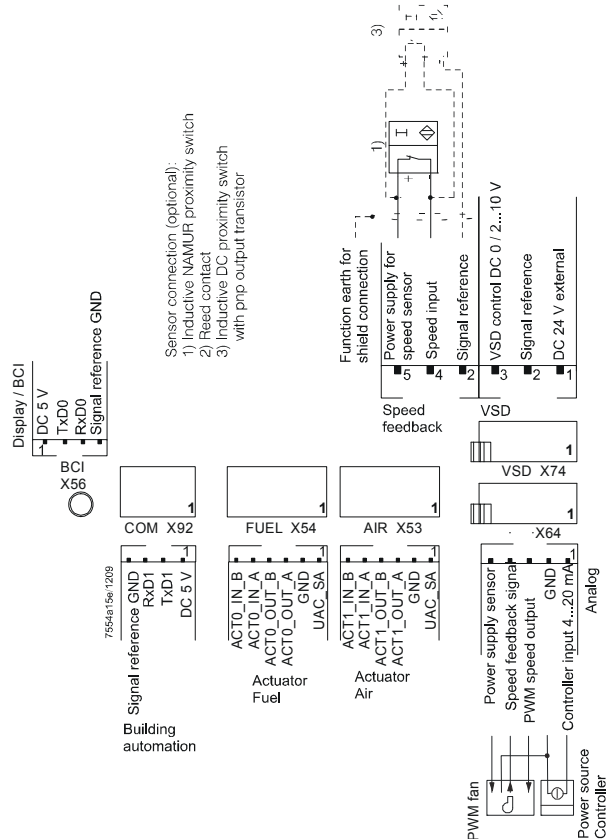

Figure 80: Inputs and outputs

16 Special feature: Burner identification (ID)

The OEM must assign an individual burner identification to every burner. This ensures that during backup/restore, incompatible parameter sets cannot be copied between different burners (also refer to the documentation on the PC software under *Backup/Restore* and in this documentation in chapter *Backup / Restore*).

No.	Parameter
113	Burner identification

17 Connection to superposed systems

17.1 General information and building automation functions

Communication with building automation is made possible via a data link using the COM X92 port and a special interface with galvanic separation and physical bus level adaptation. This port can be used for connection of a Modbus, depending on the configuration made.

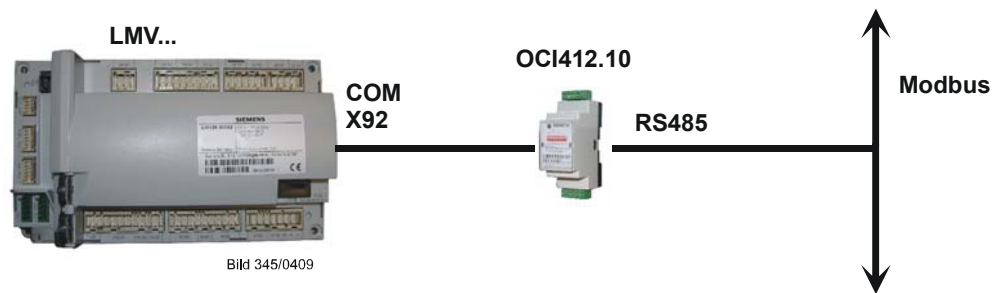

Figure 81: Connection via interface COM 92 to superposed systems



Note
Breakdown of bus communication.

If the basic unit detects a breakdown of bus communication, the BAC system must rewrite the following values upon restoration of communication:

- Modbus: Mode, Modbus operating mode, and predefined target output

General setting values for connection of the basic unit to the BAC system (for factory settings, refer to the parameter list):

Bus communication may only be interrupted for the time set.

If communication is disturbed for a longer period of time, the LMV37.4... basic unit delivers a fault status message and the values set in the basic unit by building automation are reset.

No.	Parameter
141	Operating mode building automation 0 = off 1 = Modbus 2 = reserved
142	Setback time in the event of communication breakdown Setting values 0 = deactivated 1...7200 s
148	Default output if communication with building automation is interrupted Setting values: For modulating operation the setting range is as follows: 0...19.9 = burner OFF 20...100 = 20...100% burner rating For multistage operation , the following settings apply: 0 = burner OFF, P1, P2, P3 Invalid = no default output from building automation Default setting: <i>Invalid</i>

The factory settings of the parameters are shown on the parameter list.



Note

For a detailed description of parameter 148, refer to chapter *Default output via building automation*.

17.2 Modbus

With this type of bus protocol, the LMV37.4... basic unit operates as a slave on the Modbus and the transmission mode used is RTU (Remote Terminal Unit). For more detailed information, refer to the Modbus User Documentation (A7541).

No.	Parameter
145	Device address for Modbus of basic unit Setting values 1...247
146	Setting of Baud rate for Modbus communication Setting values 0 = 9600 1 = 19200
147	Setting of parity for Modbus communication Setting values 0 = none 1 = odd 2 = even

The factory settings of the parameters are shown on the parameter list.



Note

If bus communication breaks down, the mode, Modbus operating mode and predefined target output must be rewritten.

18 PC software ACS410

The ACS410 PC software serves primarily as an operating module for the LMV37.4... system, providing the following basic functions:

- Visualization of system state via the following data:
 - Parameters
 - Process data
- Configuration and parameterization of the basic unit (individual parameters)
- Backup and recovery of parameter sets



Note
For notes on operation and commissioning, refer to chapter *Operation*.

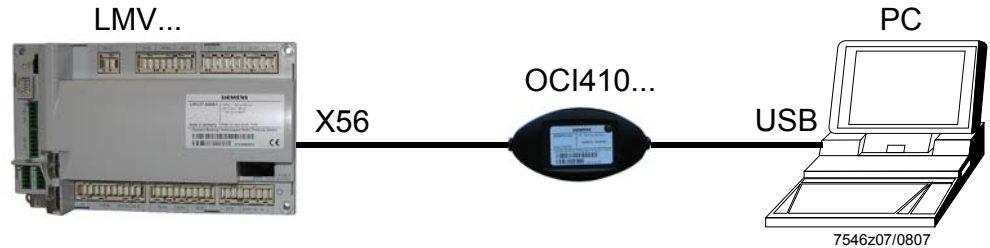

Figure 82: Communication with display / BCI (RJ11 jack) (X56)

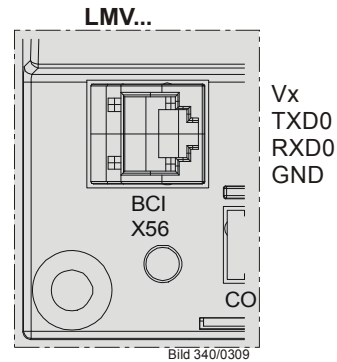

Figure 83: Display input / BCI (RJ11 jack) X56

If communication between the LMV37.4... and the ACS410 (70 s) has broken down, the password level is reset to *Info / Service*.



Caution!
Interruption of communication between the LMV37.4... and the ACS410 (30 seconds) during the time the curves are set leads to lockout!

Error-code	Diagnostic code	Meaning for the LMV3 system
167	9	Manual locking via PC software communication interruption

19 Error history

The LMV37.4... system provides an error history in which the last 25 errors are stored. The first entry represents the current error state and can also be «error-free», refer to *Error code list*.

Error code	Diagnostic code	Meaning for the LMV37.4... system
200 OFF	#	System error-free

19.1 Error classes

The errors are subdivided into error classes, depending on the severity of the switch-off response. The current error shows all classes. Only the errors of the most important classes are included in the history.

Error class	Priority	Meaning	History
0	Highest	Lockout	●
1		Safety shutdown with software reset	●
2		Undervoltage	
3		Safety shutdown: Safety phase	●
4		Safety shutdown: Start prevention	
5		Safety shutdown: Shutdown	●
6	Lowest	Message without shutdown response	

19.2 Makeup of error history

Parameter	Index	Description
701		Current error state, can also be error-free
	.01	Error code (200 = error-free) → refer to <i>Error code list</i>
	.02	Diagnostic code → refer to <i>Error code list</i>
	.03	Error class → error classes
	.04	Error phase: Phase in which error occurred → sequence diagrams
	.05	Startup counter: Startup meter reading (parameter 166) at which the error occurred
	.06	Output: Burner output at which the error occurred
702	.01..06	Latest error in the history
.		
.		
.		
725	.01..06	Oldest error in the history

Deleting the error history

Both the service menu and the parameter setting menu show the error history. The display on the service menu can be deleted in a way that the only errors shown are those that occurred after the deletion.

The error history on the parameter setting menu cannot be deleted.

For the deletion, parameter 130 must be set to **1** and then to **2** within 6 seconds.

When the parameter returns to **0**, the deletion process is completed.

No.	Parameter
130	Delete display of error history To delete the display: Set parameter to 1 , then to 2 Return value 0: Job successfully completed Return value -1: Timeout of 1_2 sequence

20 Lifecycle function

If the startup counter exceeds a defined threshold, a display error code is set and displayed. The error can be acknowledged.

The display code is always set in standby (when there is no heat request).

Hence, the moment the threshold is exceeded, the user is notified that the end of the lifecycle will soon be reached.

Error code	Diagnostic code	Meaning for the LMV37.4... system
116	0	Designed lifecycle exceeded (250,000 startups)



Note

The unit should be replaced when this message appears.

21 Safety notes on use of the AZL2...

Caution!

To prevent the risk of fire and explosions, damage to heating plant or damage resulting from improper use of the products, ensure that the following safety notes are observed:

The burner management system covered by the present Basic Documentation may only be used as specified and only in connection with the appropriate burner and heating plant.

The burner management system with its display and operating unit and the associated heating control system may only be installed and commissioned by authorized technical personnel.



The operating unit may only be used in dry spaces. Do not use it outdoors and protect it against excessive temperatures and frost, and liquids, such as water, oil, fuel oil, etc.

Follow exactly the procedures and setting notes given in this Basic Documentation. Appropriately identified settings must only be made by authorized technical personnel.

If the display and operating unit is dusty or dirty, clean it with a dry cloth.

Do not carry out any maintenance or repair work on the unit. Such work may only be performed by authorized technical personnel.

If you have any questions in connection with the display and operating unit, please contact your heating engineer or refer to one of the addresses given in this Basic Documentation.

22 Operating the AZL2... unit

22.1 Description of unit/display and buttons

Function and operation of unit versions AZL21... and AZL23... are identical.

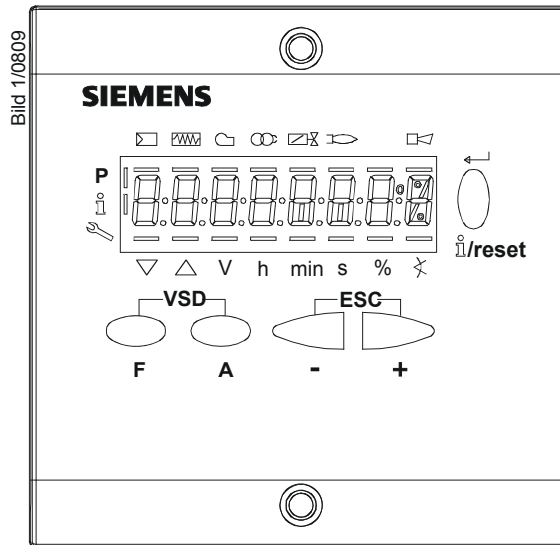







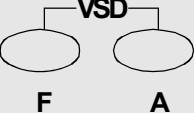







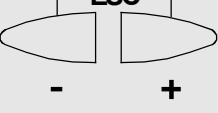



Figure 84: Description of unit/display and buttons

Button	Function
 F	Button F - For adjusting the fuel actuator (keep  depressed and adjust the value by pressing  or )
 A	Button A - For adjusting the air actuator (keep  depressed and adjust the value by pressing  or )
 F A	Buttons A and F: VSD function - For changing to parameter setting mode P (press simultaneously  and  plus  or )
 i/reset	Info and Enter button - For navigating in info or service mode * Selection (symbol flashing) (press button for <1 s) * For changing to a lower menu level (press button for 1...3 s) * For changing to a higher menu level (press button for 3...8 s) * For changing the operating mode (press button for >8 s) - Enter in parameter setting mode - Reset in the event of fault - One menu level down
 -	- button - For decreasing the value - For navigating during curve adjustments in info or service mode
 +	+ button - For increasing the value - For navigating during curve adjustments in info or service mode
 - +	+ and - button: Escape function (press  and  simultaneously) - No adoption of value - One menu level up

22.2 Meaning of symbols on the display

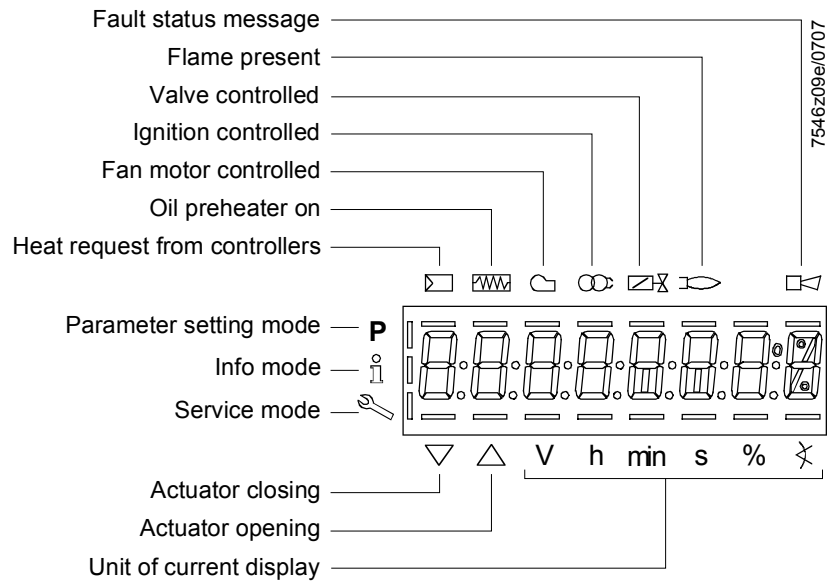

Figure 85: Meaning of display

22.3 Brightness of display

Only available with backlit LCD:



The function of the backlit display is dependent on the type of basic unit.

The brightness of the display can be adjusted from 0...100% using parameter 126.





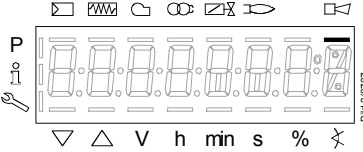

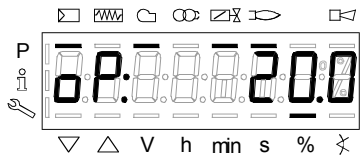

No.	Parameter
126	Brightness of display

22.4 Special functions

22.4.1 Manual lockout

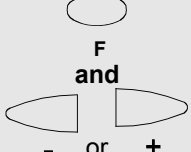
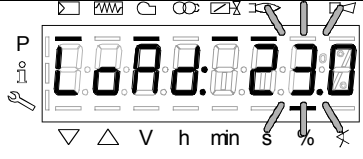
 <p>i/reset plus other button</p>		<p>Press  simultaneously with any other button.</p> <p>The basic unit switches instantly to the lockout position, irrespective of the operating position.</p> <p>The display shows the fault status message, except when in parameter setting mode.</p>
---	---	---

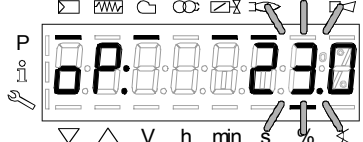
22.4.2 Manual control (manual request for output)

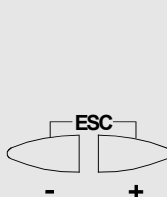
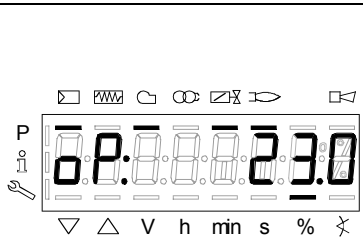
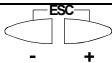
		<p>Burner is in operation.</p> <p>The display shows oP: on the left, the percentage of the current output on the right.</p> <p>Example: oP: 20.0</p>
 <p>F 1 s</p>		<p>Press  for 1 s.</p> <p>The display shows LoAd:, the current output flashes.</p>
 <p>F and - or +</p>		<p>Press  or  to adjust the required manual output.</p> <p>Example: oP: 23.0</p>
		<p>Release .</p> <p>The current manual output flashes, indicating that manual control is activated.</p>
 <p>ESC - or +</p>		<p>Press  for 3 s to return to automatic mode.</p> <p>The output no longer flashes.</p> <p>The display shows oP: on the left, the percentage value on the right.</p> <p>Example: oP: 23.0</p>

22.5 Timeout for menu operation

The time for automatically leaving the parameter setting level can be adjusted between 10 and 120 minutes, using the following parameter:

No.	Parameter
127	Timeout for menu operation

If, during that period of time, there is no operation via the AZL2..., the parameter setting level is quit and the password level reset to *Info / Service*.



Caution!

In addition, this timeout or interruption of communication between LMV37.4... and AZL2... during the time the curves are set, leads to lockout!

Error-code	Diagnostic code	Meaning for the LMV37... system
167	8	Manual locking via AZL2... Timeout / communication interruption

22.6 Backup / restore

Using the AZL2..., the settings made on the basic unit can be stored (backup) and then transferred back to the basic unit at a later point in time.

Creating a backup data set

No.	Parameter
050.0	Index 0: Creation of backup

The following parameters can be used to read information about the backup data set:

No.	Parameter
055	Burner identification of the AZL2... backup data set
056	ASN extraction of the AZL2... backup data set
057	Software version used when creating the AZL2... backup data set

Restoring a backup data set

To transfer a backup data set back to the basic unit, the parameter must be set to **1**.

No.	Parameter
050.1	Index 1: Execute restore

22.6.1 Backup

		<p>Parameter 000: flashes.</p> <p>Display: Parameter 000: flashes, Int does not.</p>	
		<p>Only OEM level</p>	<p>Press to go to parameter group 041.</p> <p>Display: Parameter 041: flashes, ._._ does not.</p>
		<p>Press to select parameter 050</p> <p>Display: Parameter 050. flashes, index 00: and value 0 do not.</p>	
			<p>Press to select parameter bAC_UP</p> <p>Display: Parameter bAC_UP</p>
			<p>Press to select the backup process.</p> <p>Display: Value 0</p>
		<p>Press to shift the value in change mode 1 position to the left.</p> <p>Display: Value 1 flashes</p> <p style="background-color: yellow;">Note To detect potential display errors, the value is displayed 1 place shifted to the left.</p>	
		<p>Press to activate the backup process.</p> <p>Display: 1 appears</p>	

Approx. 5 s		<p>After about 5 seconds (depending on the duration of the program), 0 appears on the display, indicating the end of the backup process.</p> <p>Display: 0</p>
----------------	--	--



Note

If an error occurs during the backup process, a negative value is displayed. For error diagnostics, the cause of the error can be determined from the diagnostic code of error message 137 (see *Error code list*).





Caution!

We recommend to make a backup whenever a parameter is changed!

22.6.2 Restore

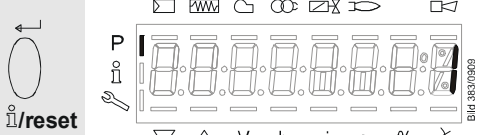
		<p>Parameter 000: flashes.</p> <p>Display: Parameter 000: flashes, Int does not.</p>
<p>Only OEM level</p>		<p>Press to go to parameter group 041.</p> <p>Display: Parameter 041: flashes, ._._ does not.</p>
		<p>Press to select parameter 050</p> <p>Display: Parameter 050. flashes, index 00: and value 0 do not.</p>
		<p>Press to go to parameter bAC_UP</p> <p>Display: Parameter bAC_UP</p>
		<p>Press to select parameter rEStorE</p> <p>Display: Parameter rEStorE</p>
		<p>Press to select the restore process.</p> <p>Display: Value 0</p>
		<p>Press to shift the value in change mode 1 position to the left.</p> <p>Display: Value 1 flashes.</p>
	<p>Note To detect potential display errors, the value is displayed 1 place shifted to the left.</p>	



Press  to activate the restore process.

Display: **1** appears

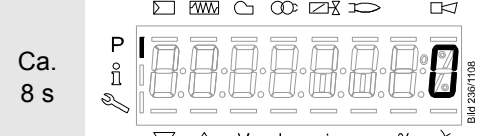

After about 8 seconds (depending on the duration of the program), **0** appears on the display, indicating the end of the backup process.

Display: **0**



Note

- Before restoring the backup data on the basic unit, the latter compares the burner identification and product no. (ASN) with the burner identification and product no. (ASN) of the backup data set. If the data accord, they are restored. If not, the restore process is aborted. In case of abortion, or if an error occurs during the restore process, the display shows a negative value. For error diagnostics, the cause of the error can be determined from the diagnostic code of error message 137 (see *Error code list*). When the restore process is successfully completed, value **0** appears on the display. The LMV37.4... is supplied with undefined burner identification. In that case, the restore process from the AZL2... is possible without having to enter the burner identification in the basic unit
- Information **Err C: 136 D: 1** (restore started) is displayed for a short moment



Caution!

- **On completion of the restore process, the sequence of functions and the parameter settings must be checked.**
- **When using a VSD, it might be necessary to repeat standardization**

23 Operation of basic unit via the AZL2...

23.1 Normal display

Normal display is the standard display in normal operation, representing the highest menu level. From the normal display, you can change to the info, service or parameter level.

23.1.1 Display in standby mode

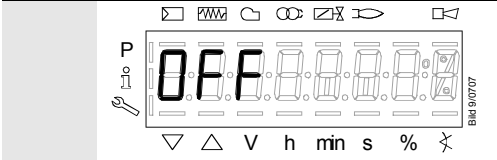

The image shows a digital display with 'OFF' in large digits. Above the display are several icons: a square with a diagonal line, a square with a circle, a square with a circle and a diagonal line, a square with a circle and a diagonal line, and a square with a circle. Below the display are navigation icons: a downward arrow, an upward arrow, a 'V' symbol, 'h', 'min', 's', '%', and a square with a diagonal line. The text 'Unit is in standby mode.' is to the right of the display. A yellow note box contains the text: 'Note OFF flashes when the Manual OFF function, the manual output, or controller OFF is activated.'

Unit is in standby mode.

Note
OFF flashes when the *Manual OFF* function, the manual output, or controller OFF is activated.

23.1.2 Display during startup / shutdown

23.1.2.1. Display of program phases

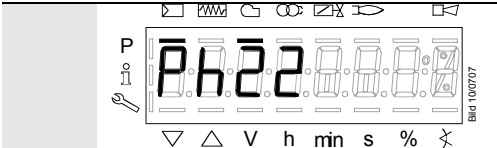

The image shows a digital display with 'PH 22' in large digits. Above the display are the same icons as in the standby mode. Below the display are the same navigation icons. The text 'The unit is in phase 22. The controller calls for heat. The bar below the □ symbol appears. The individual program phases and controlled components are displayed in accordance with the program sequence.' is to the right of the display.

The unit is in phase **22**. The controller calls for heat. The bar below the □ symbol appears. The individual program phases and controlled components are displayed in accordance with the program sequence.

23.1.2.2. Display of program phase with remaining running time until end of the phase is reached

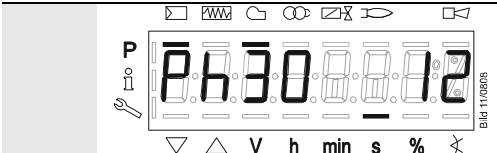

The image shows a digital display with 'PH 30' in large digits and '12' in smaller digits. Above the display are the same icons as in the standby mode. Below the display are the same navigation icons. The text 'The unit is in phase 30 and shows the remaining running time in that phase.' is to the right of the display. Below the text is the example: 'Example: 12 s, phase 30'.

The unit is in phase **30** and shows the remaining running time in that phase.

Example: **12 s**, phase **30**

23.1.2.3. List of phase displays

Phase	Function
Ph00	Lockout phase
Ph01	Safety phase
Ph10	Home run
Ph12	Standby (stationary)
Ph22	Fan ramp up time (fan motor = ON, safety valve = ON)
Ph24	Traveling to the prepurge position
Ph30	Prepurge time
Ph36	Traveling to the ignition position
Ph38	Preignition time
Ph39	Valve proving filling time (test of pressure switch-min when fitted between fuel valves V1 and V2)
Ph40	1st safety time (ignition transformer ON)
Ph42	1st safety time (ignition transformer OFF)
Ph44	Interval 1
Ph50	2nd safety time
Ph52	Interval 2
Ph60	Operation 1 (stationary)
Ph62	Max. time low-fire (operation 2, preparing for shutdown, traveling to low-fire)
Ph64	Switching back to pilot: Modulation to ignition load
Ph65	Switching back to pilot: Interval 2 waiting time
Ph66	Switching back to pilot: Reactivation of ignition + pilot
Ph67	Switching back to pilot: Shutdown of main valves
Ph68	Switching back to pilot: Pilot mode waiting phase
Ph69	Switching back to pilot: Pilot mode waiting phase for burner startup
Ph70	Afterburn time
Ph72	Traveling to the postpurge position
Ph74	Postpurge time (no extraneous light test)
Ph78	Postpurge time (t3) (abortion when load controller ON)
Ph80	Valve proving test evacuation time
Ph81	Valve proving test time atmospheric pressure, atmospheric test
Ph82	Valve proving filling test, filling
Ph83	Valve proving time gas pressure, pressure test
Ph90	Gas shortage waiting time

23.1.3 Display of operating position

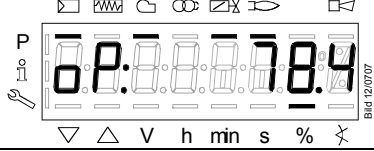
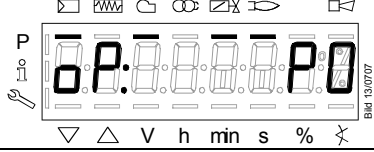
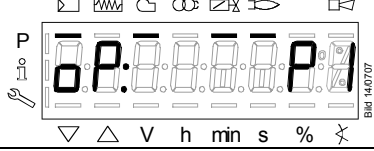
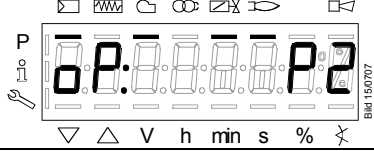
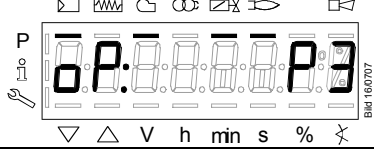
		<p>Display oP stands for «Operating position reached». Modulating mode: Current output in %</p>
		<p>Display oP: P0 stands for «Ignition point». Multistage operating mode: Current heating stage</p>
		<p>Display oP: P1 stands for «Stage 1». Multistage operating mode: Current heating stage</p>
		<p>Display oP: P2 stands for «Stage 2». Multistage operating mode: Current heating stage</p>
		<p>Display oP: P3 stands for «Stage 3». Multistage operating mode: Current heating stage</p>

23.1.4 Fault status message, display of errors and info

23.1.4.1. Display of errors (faults) with lockout

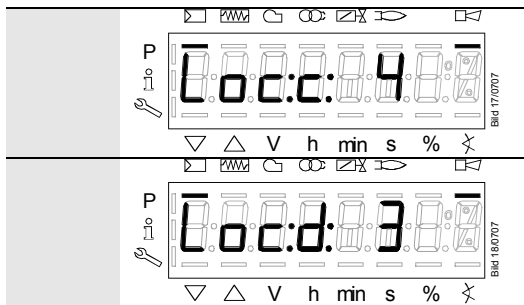

The display shows **Loc:**, the bar under the fault status message  appears.

The unit is in the lockout position.

The display shows current error code **c**: alternating with diagnostic code **d**: (refer to *Flash code list*).

Example: Error code **4**/diagnostic code **3**

23.1.4.2. Reset

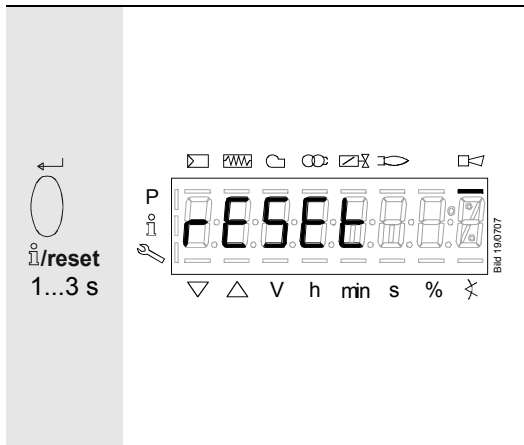

When pressing  for 1...3 s, **rESEt** appears on the display.

When the button is released, the basic unit is reset.

If the  button is pressed for a time other than the time indicated above, a change to the previous menu is made.

Exception

If an error occurred while setting the curve, a change back to the parameter setting level is made.

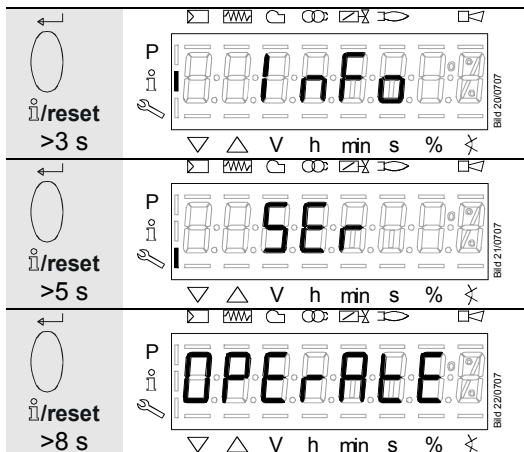

23.1.4.3. Activating info / service mode from lockout



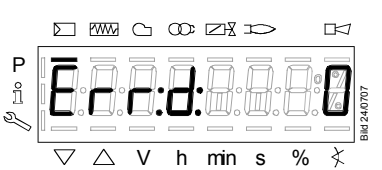

When pressing  for >3 s, the display shows **InFo**, **SEr** and then **OPERAtE**.

When the button is released, a change to info / service mode is made.

23.1.4.4. Error with safety shutdown

		<p>The display shows Err:.</p> <p>The unit initiates safety shutdown.</p> <p>The display shows current error code c: alternating with diagnostic code d:</p>
		<p>Press /reset to return to the normal display.</p> <p>Example: Error code 12 / diagnostic code 0</p>

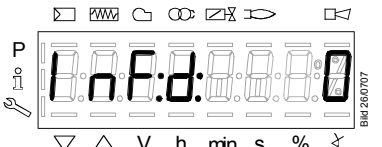
23.1.4.5. General information

		<p>The unit displays an event which does not lead to shutdown.</p> <p>The display shows current error code c: alternating with diagnostic code d:</p>
		<p>Press /reset to return to the display of phases.</p> <p>Example: Error code 111 / diagnostic code 0</p>



Note

For meaning of the error and diagnostic codes, refer to chapter *Error code list*. When an error has been acknowledged, it can still be read out from the error history.

23.1.4.6. Start prevention

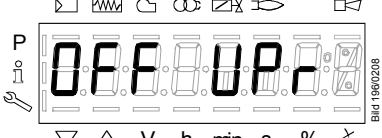
		<p>A non-programmed or not completely parameterized unit, or a unit whose operating mode was reset or changed, displays OFF UPr.</p>
--	---	---

23.1.4.7. Safety loop

		<p>A unit whose safety loop and / or burner flange contact is open, and a controller ON signal is present, displays OFF S.</p>
--	---	---

24 Menu-driven operation

24.1 Assignment of levels

The various levels can be accessed via different button combinations. The parameter level can only be accessed via password.

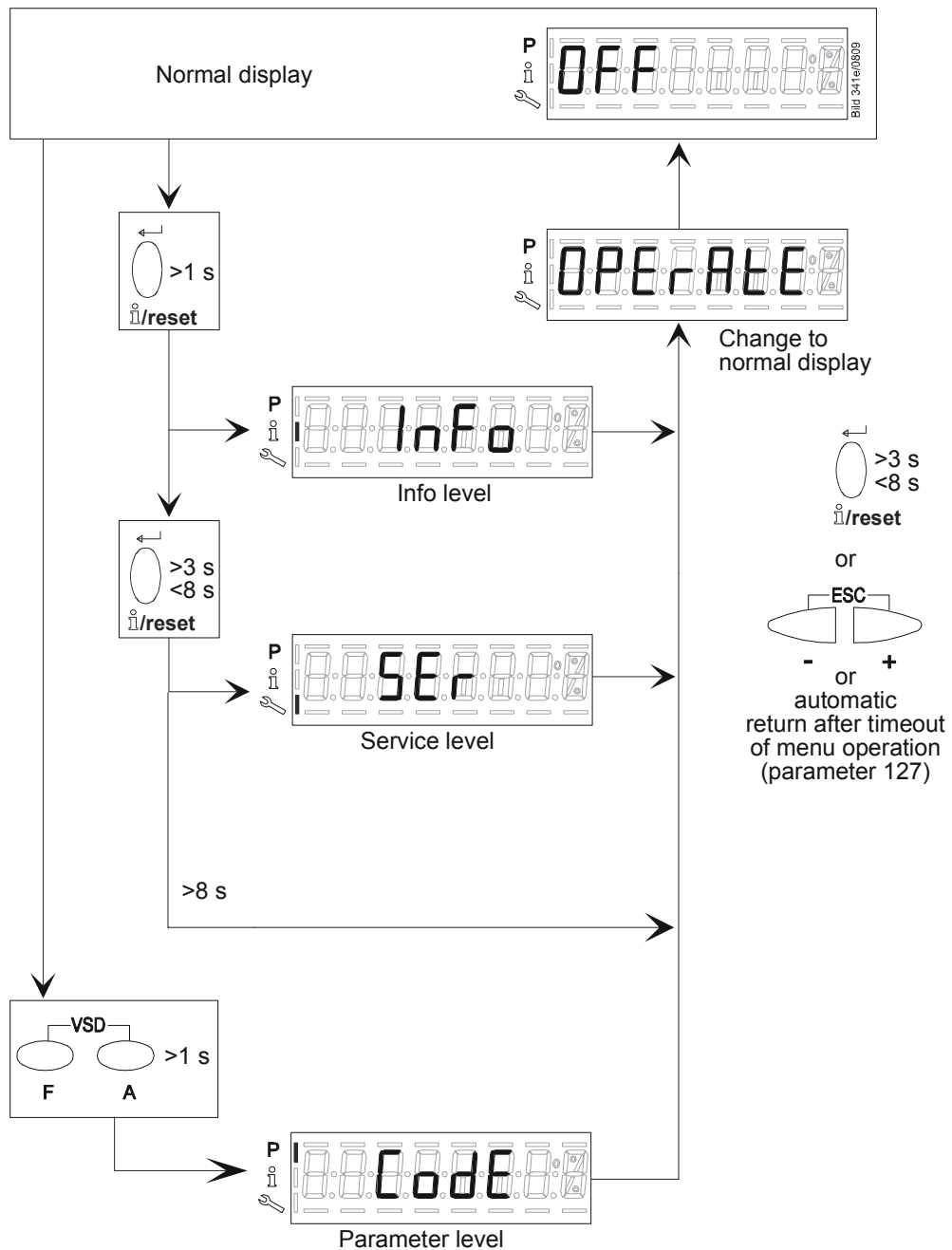

Figure 86: Assignment of levels

25 Info level

The info level displays information about the basic unit and about operation in general.



Note

On the info level, you can display the next or the previous parameter by pressing

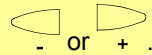

Instead of pressing + , you can also press for <1 s.



Note

Press - + or for >3 s to return to the normal display.



Note

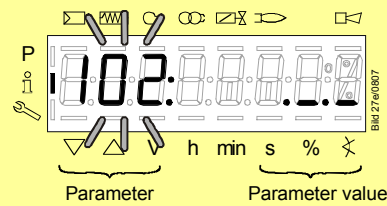

Fig. 87: Info level

No change of values on the info level!



If the display shows below the parameter value, the value may consist of more than 5 digits.

The value is displayed by pressing for >1 s and <3 s.

Press for >3 s or press - + to return to the selection of the parameter (parameter no. flashes).

No.	Parameter
Info level	
167	Fuel volume resettable (m ³ , l, ft ³ , gal)
162	Operating hours resettable
164	Startups resettable
176	<i>Switching back to pilot switching cycles</i>
163	Operating hours when unit is live
166	Total number of startups
113	Burner identification
107	Software version
108	Software variant
102	Identification date
103	Identification number
104	Preselected parameter set: Customer code
105	Preselected parameter set: Version
143	Reserve
End	

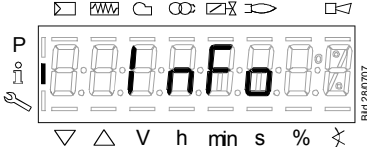

25.1 Display of info level

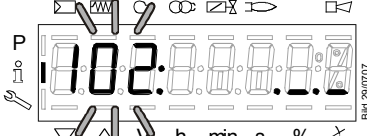

 <p>Info/reset 1...3 s</p>		<p>Press  until InFo appears.</p> <p>When releasing , you are on the info level.</p>
---	---	---

25.2 Display of info values (examples)

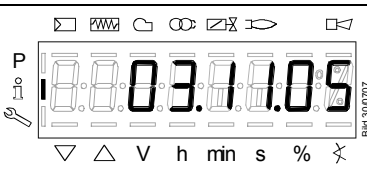
25.2.1 Identification date

		<p>The display shows parameter 102: flashing on the left, characters ._._ on the right.</p> <p>Example: 102: ._. _</p>
--	---	---

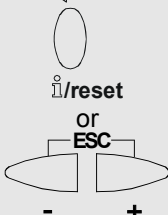
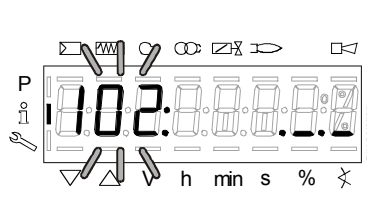
 <p>Info/reset 1...3 s</p>		<p>Press  for 1...3 s to show the identification date TT.MM.JJ.</p> <p>Example: Identification date 03.11.05</p>
---	---	---

		<p>Press  for >3 s or  to return to the display of parameters.</p>
--	--	---

To the next parameter

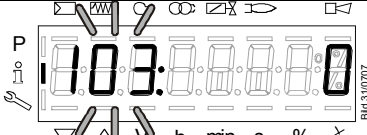

25.2.2 Identification number

		<p>The display shows parameter 103: flashing on the left, identification number 0 on the right.</p> <p>Example: 103: 0</p>
--	---	---

To the next parameter

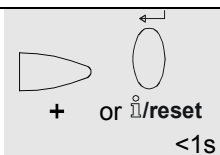

Back to the previous parameter

25.2.3 Burner identification

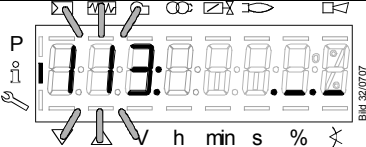

The display shows parameter **113**: flashing on the left, characters **. _ . _** on the right.

Example: **113**: **. _ . _**

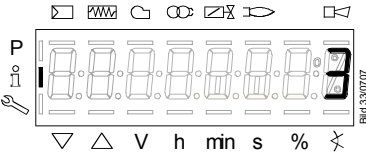

Press  for 1...3 s to show the burner's identification.

Default setting: **-----**

Example: **3**

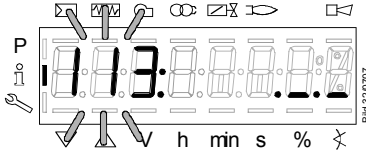

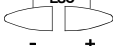
Press  or  to return to the display of parameters.

The burner's identification can be set on the parameter level!

To the next parameter 

Back to the previous parameter 

25.2.4 Number of startups resettable

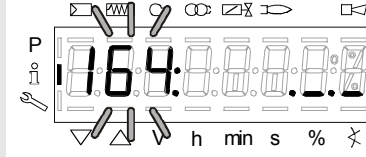

The display shows parameter **164**: flashing on the left, characters **. _ . _** on the right, since display of the number of startups may comprise more than 5 digits.

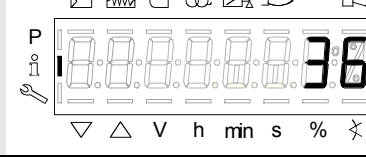

Example: Parameter **164**: **. _ . _**

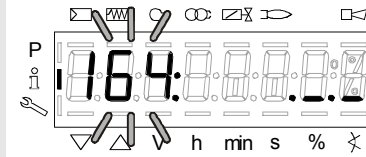

Press  for 1...3 s to show the number of startups (resettable).

Example: **36**



Press  or  to show parameter **164** flashing again.

The number of startups can be reset on the parameter level!

To the next parameter 

Back to the previous parameter 

25.2.5 Total number of startups

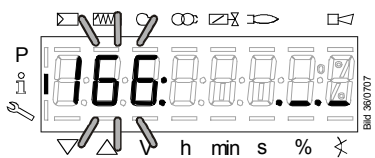

The display shows parameter **166**: flashing on the left, characters **._.** on the right, since the display of the total number of startups may comprise more than 5 digits.

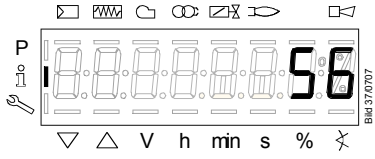

Example: Parameter **166**: **._.**

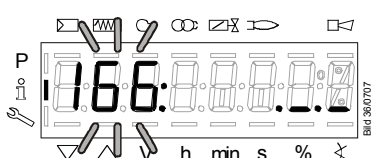

Press  for 1...3 s to show the total number of startups.

Example: **56**



Press  or  to return to the display of parameters.

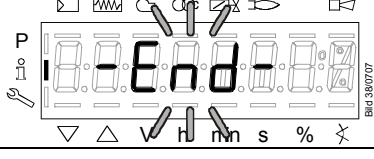

To the next parameter  Back to the previous parameter 

25.2.6 End of info level





When this display appears, you have reached the end of the info level.

The display shows **- End -** flashing.

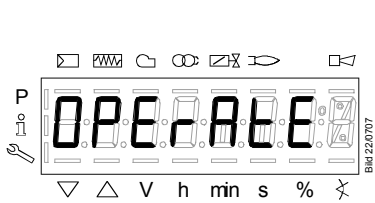
To the start of the info level  or  **<1s** Back to the previous parameter 



Press  for >3 s or  to return to the normal display.

OPErAtE appears for a short moment.

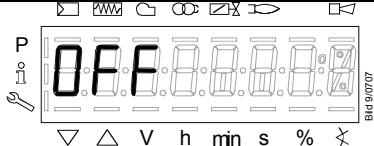

When this display appears, you are back on the normal display and you can change to the next level mode.

26 Service level

The service level is used to display information about errors including the error history and information about the basic unit.



Note

When on the service level, you can press or to display the next or the previous parameter.

Instead of pressing , you can also press for <1 s.



Note

Press or for >3 s to return to the normal display.



Note

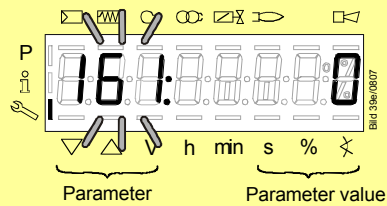

Figure 88: Service level

No change of values on the service level.

If characters are displayed by the parameter, the value may consist of more than 5 digits.

Press for >1 s and <3 s to display the value.

Press for >3 s or to return to the selection of the parameter (flashing).

26.1 Display of service level

No.	Parameter
Service level	
954	Flame intensity
960	Actual flow rate (fuel throughput in m ³ /h, l/h, ft ³ /h, gal/h)
121	Manual output Undefined = automatic operation
922	Incremental position of actuators Index 0 = fuel Index 1 = air
936	Standardized speed
161	Number of faults
701	Error history: 701-725.01.Code
.	
.	
.	
725	

26.2 Display of service values (example)

26.2.1 Number of faults

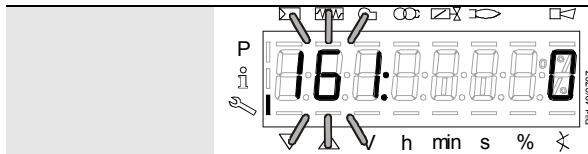

The display shows parameter **161**: flashing on the left, the number of faults that occurred thus far on the right **0**.

Example: Parameter **161: 0**

To the next parameter

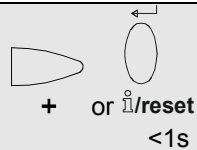

Back to the previous parameter

26.2.2 Error history

Refer to chapter *Parameter with index, without direct display / Example of parameter 701: Error history!*



Note

Can be deleted for service (refer to chapter *Parameter list!*)

26.2.3 Intensity of flame

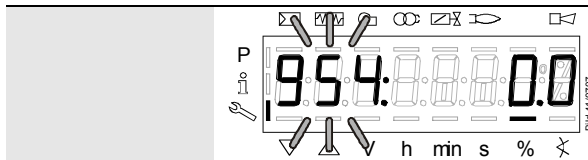

The display shows parameter **954**: flashing on the left.

On the right, the flame's intensity is displayed as a percentage.

Example: **954: 0.0**

To the next parameter

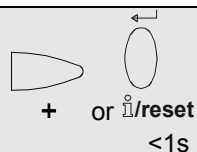

Back to the previous parameter



Note

Also refer to chapter *Intensity of flame during curve settings.*

26.2.4 End of service level

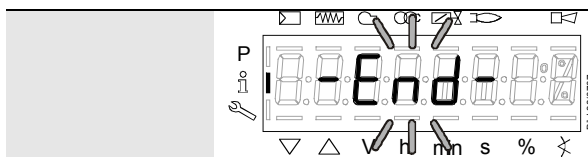

When this display appears, you have reached the end of the service level.

Display – **End** – appears flashing.

To the start of the service level

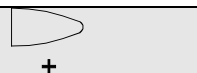

Back to the previous parameter

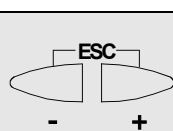

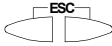
Press  to return to the normal display. **OPERAtE** appears for a short moment.

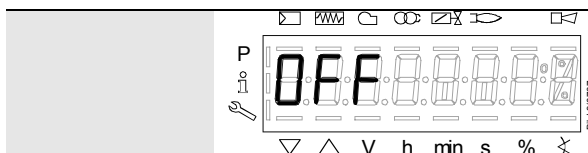

When this display appears, you are back on the normal display and you can change to the next level mode.

27 Parameter level

The parameters stored in the basic unit can be displayed or changed on the parameter level.

The change to the parameter level requires a password.

Siemens supplies the LMV37.4... with the factory settings according to *Type summary*.

The OEM can change the Siemens default settings to match his own requirements.

With the LMV37.4..., the basic unit's characteristics are determined primarily through parameter settings. Every time the unit is recommissioned, the parameter settings must be checked. The LMV37.4... must never be transferred from one plant to another without matching the parameters to the new plant.

Caution!

Parameters and settings may only be changed by **qualified personnel**.

If parameters are changed, responsibility for the new parameter settings is assumed by the person who – in accordance with the access rights – has made parameter changes on the respective access level.

After parameterization, the OEM must check to ensure that safe burner operation is warranted.

The OEM which made the settings is always responsible for the parameters, their settings and compliance of the respective application with the relevant national and international standards and safety regulations, such as EN 676, EN 267, EN 1643, etc.

Siemens, its suppliers and other Group Companies of Siemens AG do not assume responsibility for special or indirect damage, consequential damage, other damage, or damage resulting from wrong parameter settings.



Warning!

If the factory settings are changed, all changes made must be documented and checked by the OEM.

The OEM is obliged to mark the unit accordingly and to include at least the list of device parameters and settings in the burner's documentation.

Siemens also recommends attaching an additional mark on the LMV37.4... in the form of an adhesive label. According to EN 298, the label should be easy to read and wipe proof.

The label with a maximum size of 70 mm x 45 mm can be attached to the upper part of the housing.



Example of label:

OEM logo

Type / part no.: 1234567890ABCD

Caution! OEM settings:

Parameter

225 = 30 s (t1)

226 = 2 s (t3)

230 = 10 s (t4)

234 = 0 s (t8)

240 = 1 (repetition)

257 = 2 s (t3n)

TSA = t3n + 0.7 s

259 = 30 s (t11)

260 = 30 s (t12)

27.1 Entry of password



Note

The OEM's password must consist of 5 characters, the heating engineer of 4 characters.

		<p>Press button combination to display CodE.</p>
		<p>When releasing the buttons, 7 bars appear the first of which flashes.</p>
		<p>Press to select a number or letter.</p>
		<p>Press to confirm the value.</p> <p>The value entered changes to a minus sign (-).</p> <p>The next bar starts flashing.</p>
		<p>Press to select a number or letter.</p>
<p>•</p> <p>•</p> <p>•</p>		
		<p>After entry of the last character, the password must be confirmed by pressing .</p> <p>Example: Password consisting of 4 characters.</p>

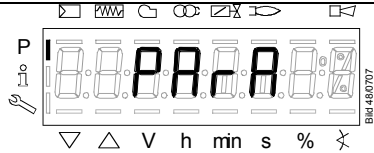

As a confirmation of correct entry, **PArA** appears for a maximum of 2 seconds.



Note

For entry of passwords or burner IDs, the following numbers and letters can be used:

	= 1		= A		= L
	= 2		= b		= n
	= 3		= C		= o
	= 4		= d		= P
	= 5		= E		= r
	= 6		= F		= S
	= 7		= G		= t
	= 8		= H		= u
	= 9		= I		= Y
	= 0		= J		

27.2 Entry of burner identification

The burner's identification is entered like a password (character by character), but from right to left and ending with «_».

		<p>Parameter 113: flashes.</p> <p>Press /reset to go to editing mode.</p>
		<p>You are on the display for undefined burner identification. 8 bars appear.</p>
		<p>Press or to select a number. Example: Number 3 flashes.</p>
		<p>Press /reset to confirm the value.</p> <p>Make the entry number by number.</p>
		<p>Press or to select the next number. Example: Number 9 flashes.</p>
		<p>After entry of the last number, burner identification must be confirmed by pressing /reset.</p>

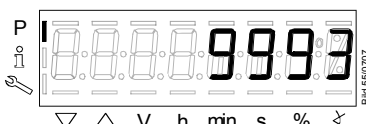

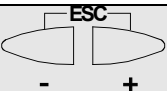
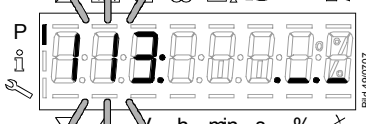

The display no longer flashes.
Example: Burner identification **9993**

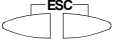

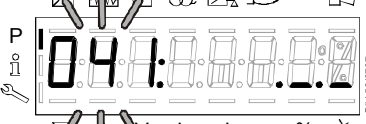

Press  to return to the parameter level.
PARAmeter 113: for burner identification.

27.3 Change of heating engineer's password

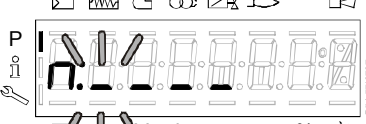

Parameter **041**: flashes.
Press  to go to level **c**: for password changes.



Letter **n**: for new.
Proceed as described in chapter *Entry of password* and enter the new password (4 characters).
After entry of the last character, the password must be confirmed by pressing .

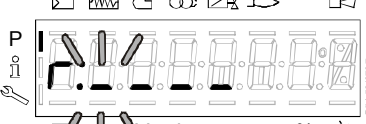

Letter **r**: for repeat.
Proceed as described in chapter *Entry of password* and repeat entry of the new password.
After entry of the last character, the password must be confirmed by pressing .





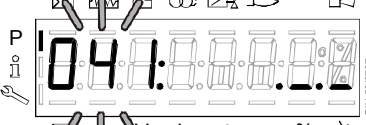



SEt confirms that the new password has been saved.

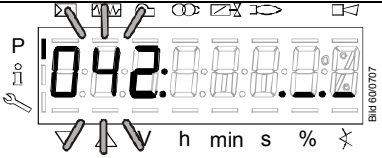

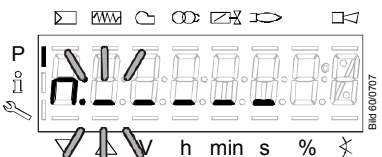
Parameter **041**: flashes again.

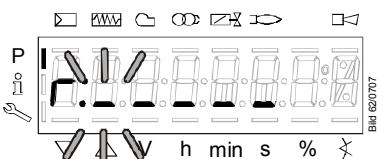
27.4 Change of OEM's password

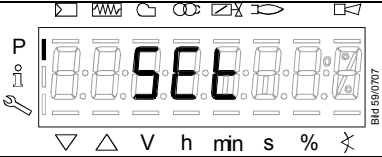
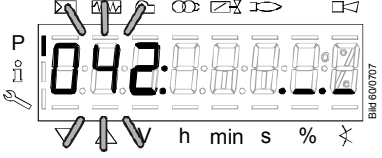
	<p>Parameter 042: flashes.</p> <p>Press  to go to level c: for password changes.</p>
	<p>Letter n: for new.</p> <p>Proceed as described in chapter <i>Entry of password</i> and enter the new password (5 characters).</p> <p>After entry of the last character, the password must be confirmed by pressing .</p>
	<p>Letter r: for repeat.</p> <p>Proceed as described in chapter <i>Entry of password</i> and repeat entry of the new password.</p> <p>After entry of the last character, the password must be confirmed by pressing .</p>
	<p>SEt confirms that the new password has been saved.</p>
	<p>Parameter 042: flashes again.</p>

27.5 Use of parameter level

The parameters stored in the LMV37.4... basic unit can be displayed and changed on the parameter level. Normally, all parameters have been set by the burner manufacturer – with the exception of those for the fuel train and for air-fuel ratio control.

A description of parameter level **400**, which is used for setting the fuel train and the fuel-air ratio curve, is given in chapter *Air-fuel ratio curves – settings and commissioning*.

27.6 Structure of parameter levels

The parameters are assigned to different levels.

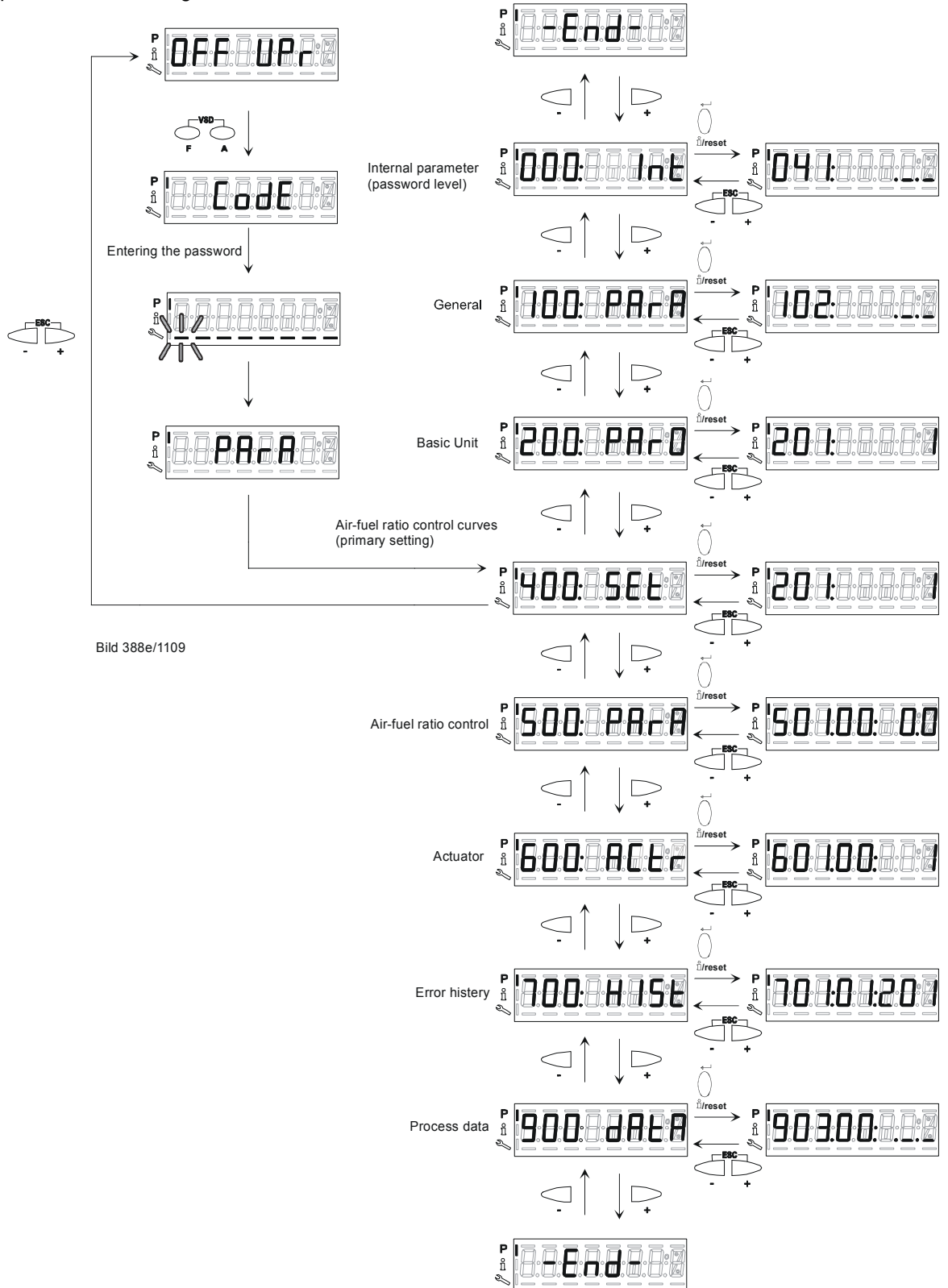

Figure 89: Structure of parameter levels



Note

The following sections explain the operating philosophy behind the parameter levels using a number of examples.



Caution!

Pay special attention to chapter **Safety notes on settings and parameter settings!**

27.7 Parameters without index, with direct display

27.7.1 Using the example of parameter 208: Program stop

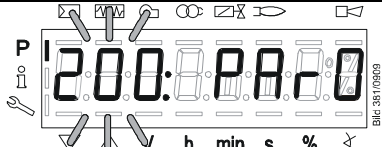

PARAmeter level 200: for basic units.

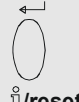

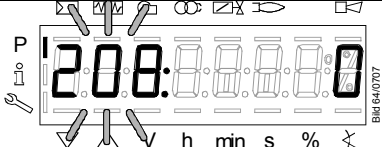

Press /reset to go to menu level **200**:





Press  to select «Program stop».

Display: Parameter **208**: flashes, value **0** does not.



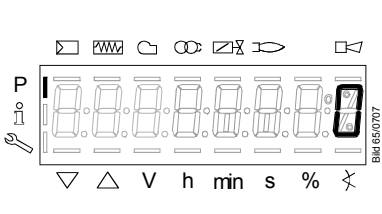

/reset

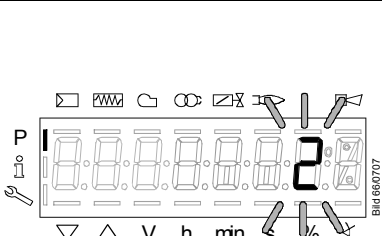

Press /reset to go to editing mode.

Display:
Program stop time set
Here: Value **0**
→ corresponding to program stop deactivated.



Press  or  to select the required program stop time.

0 = deactivated
1 = PrePurgP (Ph24)
2 = IgnitPos (Ph36)
3 = Interv1 (Ph44)
4 = Interv2 (Ph52)

Example: **2** IgnitPos (Ph36)

Adopt the value!

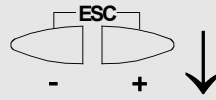

Discard the change!

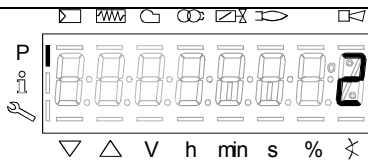

Press  to return to editing mode.

The value set is adopted.

Note

To detect potential display errors, the value is displayed 1 place shifted to the right.

Display: Value 2

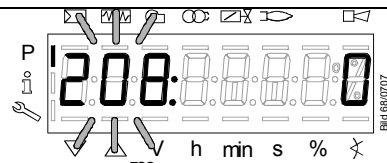

Press - + to return to the parameter level.

Display: Parameter 208: flashes, value 0 does not.

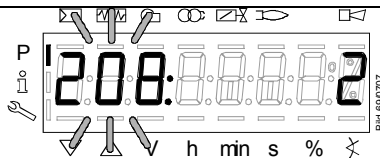
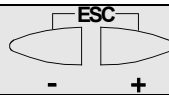

Press - + to return to the parameter level.

PARAmeter 208: flashes, value 2 does not.

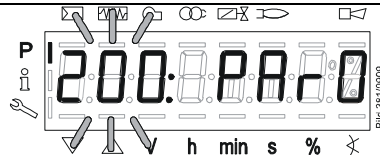
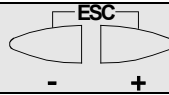

Press - + to return to the parameter level.

PARAmeter 200: for basic units.

To the next parameter level



Back to the previous parameter level

27.8 Parameters without index, with no direct display (with parameters having a value range >5 digits)

27.8.1 Using the example of parameter 162: Operating hours resettable

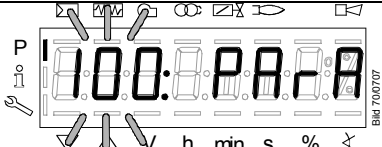

ParAmeter level **100**: for general.



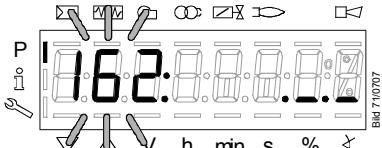

Press /reset to go to menu level **100**.

Press  to select «Operating hours resettable».

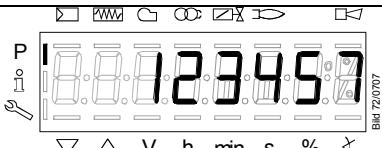

Display: Parameter **162**: flashes, characters **.-.-** do not.

Press  to go to editing mode.

Display: **123457**

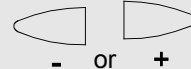
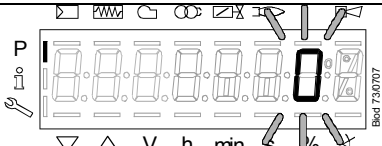
You can press  or  to set the number of operating hours to **0**.

Display: Operating hours **0** flashes.

Adopt the value!

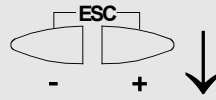
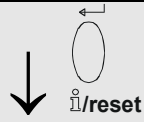

Discard the change!

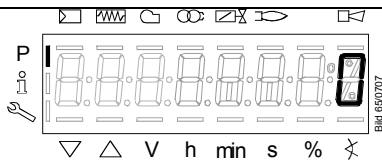

Press  to return to editing mode.

The value set will be adopted.

Note

To detect potential display errors, the value is displayed 1 place shifted to the right.

Display: Value 0

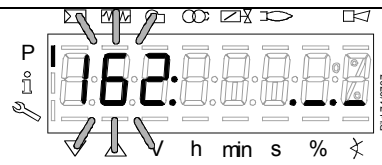

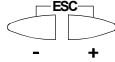
Press  to return to the parameter level.

Display: Parameter **162**: flashes, characters '-.-' do not.

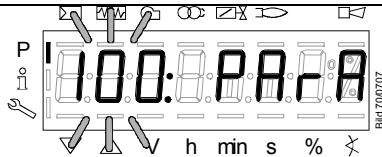
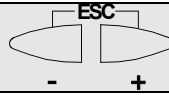

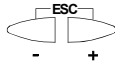









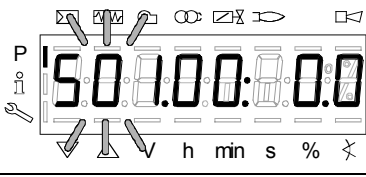

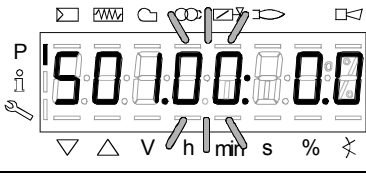

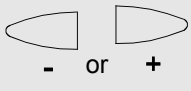
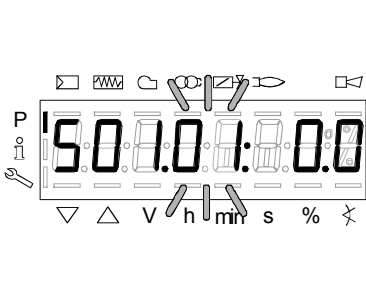
Press  to return to the parameter level.

PArAmeter 100: for general.

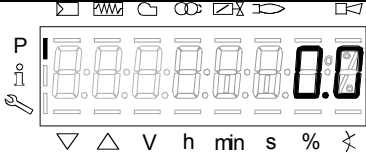
27.9 Parameter with index, with direct display

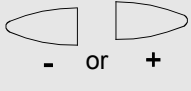
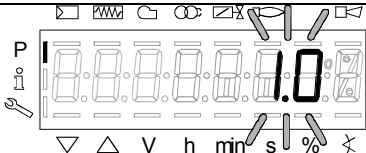
27.9.1 Using the example of parameter 501: No-flame positions fuel actuator

		<p>PArAmeter level 500: for air-fuel ratio control.</p>
		
		<p>Press  to go to menu level 500:</p> <p>Display: Parameter 501. flashes, index 00: and value 0.0 do not.</p>
		
		<p>Press  to go to the index.</p> <p>Display: Parameter 501. does not flash, index 00: flashes, value 0.0 does not.</p>
		<p>Press  or  to select the required index.</p> <ul style="list-style-type: none"> .00 = home position .01 = prepurge position .02 = postpurge position <p>Display: Index 01: for prepurge position flashes, value 0.0 does not.</p>
		
		<p>Press  to go to editing mode.</p> <p>Display: Value 0.0</p>
		<p>Press  or  to select the required prepurge position.</p> <p>Example: 1.0</p>

Adopt the value!

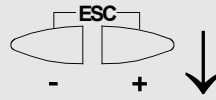
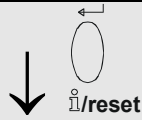

Discard the change!

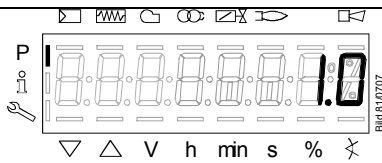

Press  to return to editing mode.

The value set will be adopted.

Note

To detect potential display errors, the value is displayed 1 place shifted to the right.

Display: Value 1.0

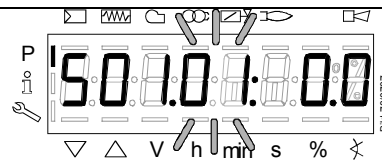

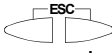
Press  to return to the index.

Display: Parameter 501. does not flash, index 01: flashes, value 0.0 has not changed and does not flash.

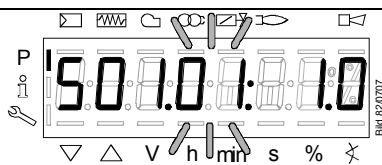
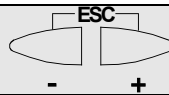

Press  to return to the index.

PARAmeter 501: does not flash, index 01: flashes, value 1.0 does not.

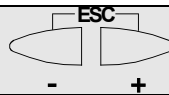

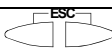
Press  to return to the parameter level.

Display: Parameter 501. flashes, index 00: and value 0.0 do not.

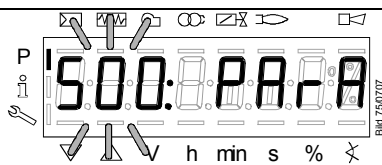
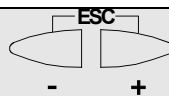

Press  to return to the parameter level.

PARAmeter 500: for air-fuel ratio control.

27.10 Parameters with index, with no direct display

27.10.1 Using the example of parameter 701: Errors

Refer to chapter *Error code list!*



Note

Can be deleted for service, refer to chapter *Parameter list!*

HIStorie 700: for error history.

Press **i/reset** to go to the parameter level.

Press **+** to select parameter **701**.

Display: Parameter **701**. flashes, index **01**: and value **201** do not.

Press **i/reset** to go to index **01**:

Display: Parameter **701**. does not flash, index **01**: flashes, value **201** does not.

To the next index Back to the previous index

Press **+** to select the index:

- .01 = error code
- .02 = diagnostic code
- .03 = error class
- .04 = error phase
- .05 = startup counter
- .06 = output

Example:
Parameter **701**., index **05**: for startup counter, diagnostic code **--**

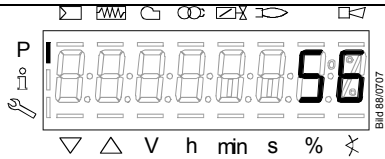

Press  to go to display mode.

Display: Value **56**

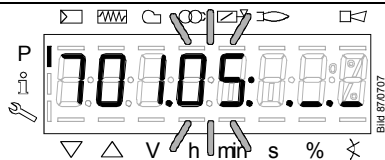
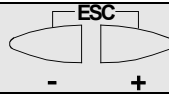

Press  to return to the index.

Display: Parameter **701.** does not flash, index **05:** flashes, characters **.-.-** do not.

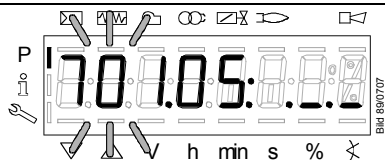
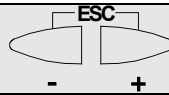

Press  to return to the parameter level.

Display: Parameter **701.** flashes index **05:** does not, characters **.-.-** do not.

To the next older error

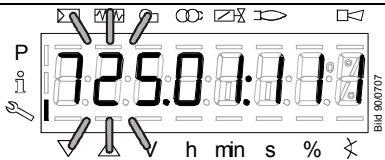

Parameters cover the period of time back to the last error since history was deleted (max. to parameter **725.**)

Example:
Parameter **725.**, index **01:**, error code **111**

To the next parameter



Back to the previous parameter

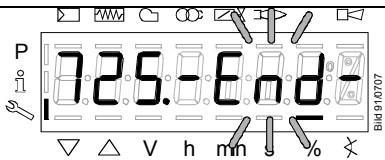

When this display appears, you have reached the end of the error history index.

Display **- End -** appears flashing.

To the next parameter

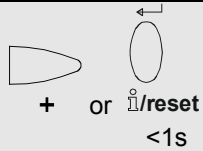

Back to the previous parameter

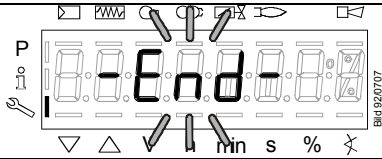

When this display appears, you have reached the end of the error history.

Display **– End –** appears flashing.

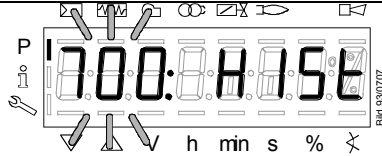
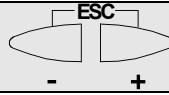

Press **- +** to return to the parameter level.

HISt 700: for error history

To the next parameter

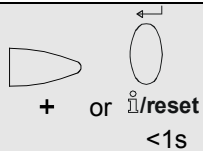

Back to the previous parameter



Note

If you wish, you can delete the error history via parameter **130**.

To delete the display, set the parameter to **1** and then to **2**.

The error history is deleted when the parameter has returned to **0**.

27.11 Air-fuel ratio curves – settings and commissioning

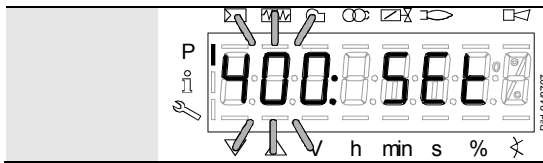

The display shows **400**: flashing on the left, **SEt** appears on the right.

27.11.1 Initial commissioning

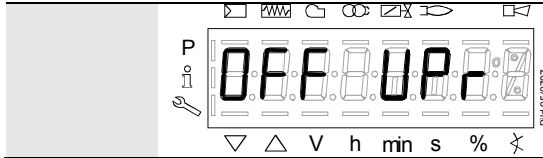

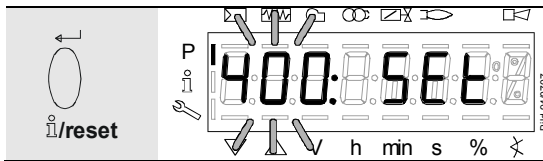

An unprogrammed unit or a unit whose operating mode has been reset or changed displays **OFF UPr**.

For initial commissioning, change to the parameter level (refer to chapter *Operation*). The settings can then be made on parameter level **400**.

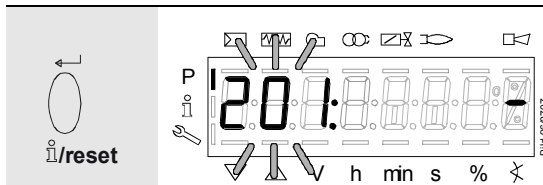

Press  to select parameter **400** for initial commissioning and for setting air-fuel ratio control.



Press  to go to the settings for air-fuel ratio control and parameter **201** for selecting the operating mode.

201: appears flashing.





Note

Ensure that the fuel train is correctly set in compliance with the type of burner used.

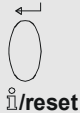
No.	Parameter	Actuator controlled	
		Air	Fuel
201	Burner operating mode (fuel train, modulating / multistage, actuators, etc.)	●	●
	-- = undefined (delete curves)	●	●
	1 = gas modulating (G mod)	●	●
	2 = gas modulating with pilot valve (Gp1 mod)	●	●
	3 = gas modulating with pilot valve (Gp2 mod)	●	●
	4 = oil modulating (Lo mod)	●	●
	5 = oil 2-stage (Lo 2 stage)	●	---
	6 = oil 3-stage (Lo 3 stage)	●	---
	7 = gas modulating (G mod pneu)	●	---
	8 = gas modulating (Gp1 mod pneu)	●	---
	9 = gas modulating (Gp2 mod pneu)	●	---
	10 = oil modulating with gas pilot (LoGp mod)	●	●
	11 = oil 2-stage with gas pilot (LoGp 2-stage)	●	---
	12 = oil modulating with 2 fuel valves (Lo mod 2V)	●	●
	13 = oil modulating with gas pilot and 2 fuel valves (LoGp mod 2V)	●	●
	14 = gas modulating (G mod pneu, 0 active)	---	---
	15 = gas modulating with pilot (Gp1 mod pneu, 0 active)	---	---
	16 = gas modulating with pilot (Gp2 mod pneu, 0 active)	---	---
	17 = oil 2-stage (Lo 2-stage, 0 active)	---	---
	18 = oil 3-stage (Lo 3-stage, 0 active)	---	---
	19 = gas modulating only when firing on gas (G mod fuel active)	---	●
	20 = gas modulating with pilot only when firing on gas (Gp1 mod fuel active)	---	●
	21 = gas modulating with pilot only when firing on gas (Gp2 mod fuel active)	---	●
	22 = oil modulating only when firing on oil (Lo mod fuel active)	---	●
	23 = Heavy oil modulating with circulation	●	●
	24 = Heavy oil 2-stage with circulation	●	---
	25 = Heavy oil modulation without circulation control	●	●
26 = Heavy oil 2-stage without circulation control	●	---	
27 = Heavy oil 3-stage without circulation control	●	---	

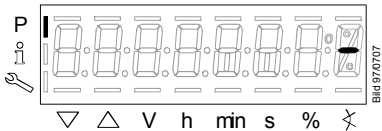

 **i/reset**

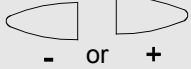

Press  **i/reset** to go to editing mode.

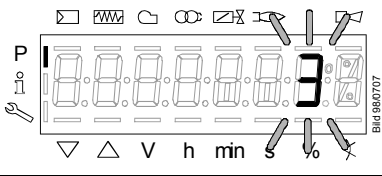
 - or +



Press  or  to select the required setting.

Example: **3** for gas modulating with pilot valve (Gp2 mod)

 **i/reset**

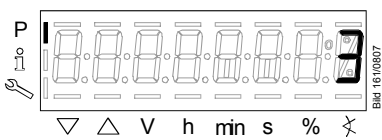

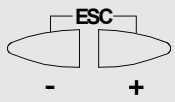

Press  **i/reset** to save the selected setting.

 **ESC**

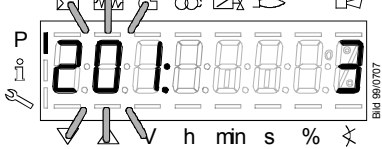
- +



Press  **ESC** +  to return to the parameter level.

To the next parameter  +

 **i/reset**

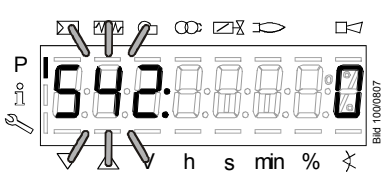

Press  **i/reset** to change to parameter **542**: to activate the VSD / PWM fan.

You can choose:

- 0 = VSD / PWM fan OFF
- 1 = VSD / PWM fan ON

To the next parameter  +

 - Back to the previous parameter

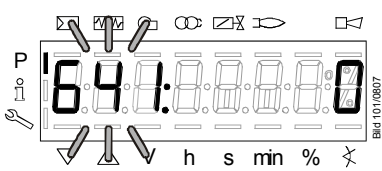

Press  + to change to parameter **641**: to control speed standardization of the VSD.

You can choose:

- 0 = speed standardization of VSD OFF
- 1 = speed standardization of VSD ON

After setting speed standardization to **1**, standardization of the VSD commences. If successful, the parameter is reset to **0**. Negative values indicate errors (refer to chapter *Automatic speed standardization*).

- For operating modes 1...4, 7...10, 12...16 and 19...22, refer to chapter *Setting curvepoints P0, P1 and P9 for modulating mode («G mod», «Gp1 mod», «Gp2 mod» and «Lo mod»)*
- For operating modes 5, 6, 11, 17 and 18, refer to chapter *Setting the curvepoints for multistage mode («Lo 2-stage» and «Lo 3-stage»)*

To the next parameter  +

27.11.2 Setting curvepoints P0 and P9 for modulating mode («G mod», «Gp1 mod», «Gp2 mod» and «Lo mod»)



Note

Not all actuators used in the following example can be set, depending on the selected operating mode.

Example of «G mod»

		<p>Display P0 appears flashing.</p> <p>Curvepoint for ignition load.</p>
		<p>Keep F depressed.</p> <p>You are now in setting P0 of fuel setting F for ignition position P0.</p>
		<p>Press simultaneously F and - or + to set ignition position P0 of the fuel damper.</p> <p>Example: 30.0</p>
		<p>Release F.</p> <p>The selected value is adopted.</p> <p>Example: 30.0</p>
		<p>Keep A depressed.</p> <p>You are now in setting P0 of air actuator A for ignition position P0.</p>
		<p>Press simultaneously A and - or + to set ignition position P0 of the air actuator.</p> <p>Example: 22.0</p>
		<p>Release A.</p> <p>The selected value is adopted.</p> <p>Example: 22.0</p>
		<p>Keep F and A depressed.</p> <p>You are now in setting n0, speed n is for ignition position n0</p>

Press simultaneously **F** and **A** and **-** or **+** to adjust speed **n0** of the load controller.
 Example: **20.0**

Release **F** and **A**.
 The selected value is adopted.
 Example: **20.0**

To the next curvepoint

Press **+**.

P9 appears flashing.

Curvepoint for high-fire.

Same procedure as with **P0**

Note:
 If **-** is pressed first, the display jumps to 90!

To the next curvepoint Back to the previous curvepoint

Press **+**.

The display shows **run** (identification of start for setting the curve parameters).

Note

When pressing , you are given the choice of proceeding with the "warm settings" (refer to chapter *Warm settings for modulating mode* («G mod», «Gp1 mod», «Gp2 mod» and «Lo mod») or, by pressing , with the "cold settings" (refer to chapter *Cold settings for* «G mod», «Gp1 mod», «Gp2 mod» and «Lo mod»).

27.11.3 Setting curvepoints P0 and P9 for «G mod pneu», «Gp1 mod pneu» and «Gp2 mod pneu»



Note

Refer to chapter *Setting curvepoints P0 and P9 for modulating mode («G mod», «Gp1 mod», «Gp2 mod» and «Lo mod»)*! Here, only the air requires adjustment with A .

27.11.4 Warm settings for modulating mode («G mod», «Gp1 mod», «Gp2 mod» and «Lo mod» and «Ho mod»)



Note

With the warm settings, the burner is started up after pressing the **Info** button. Air-fuel ratio control can now be accurately set while the flame is present. When traveling along the precalculated curve to high-fire point **P9**, all intermediate curvepoints (**P2...P8**) must be set. Automatic operation is released when – after reaching **P9** – the curve settings are quit by pressing **ESC**. If the curve settings are aborted earlier (**ESC** or shutdown due to fault), start prevention **OFF UPr** continues to be active until all points are set. If required, the gas pressure can be set at the high-fire point. In case the gas pressure is changed, all points must be checked by traveling along the curve downward and – if required – must be readjusted.

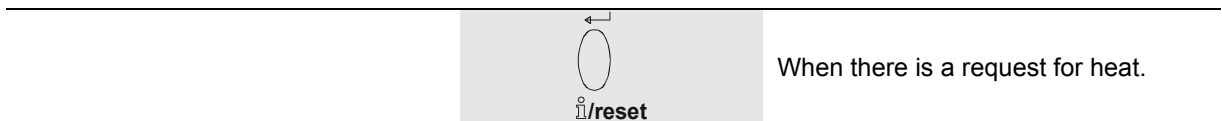
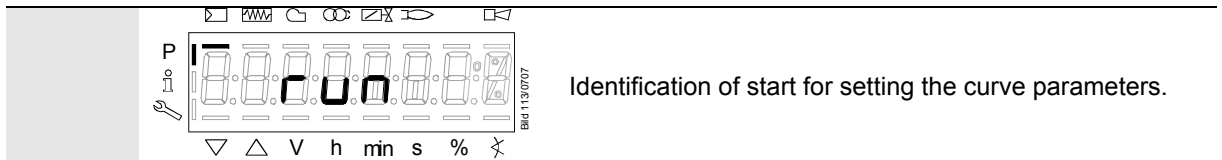

Note

If, during the time the curve is parameterized, an error occurs which leads to safety shutdown, parameterization of the curve is quit.

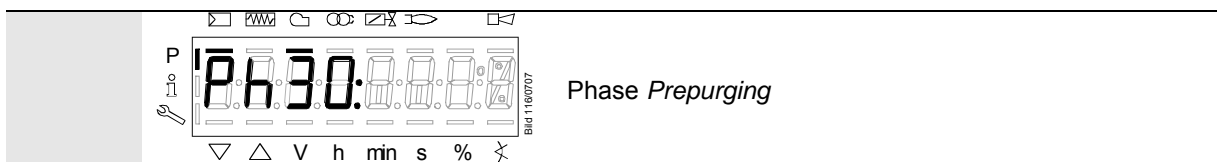
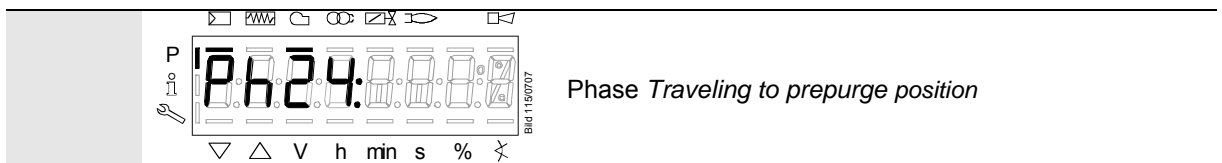
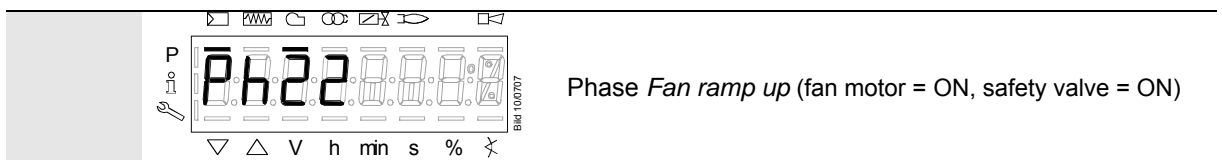

Phase *Traveling to ignition position*

Wait until the burner is operating and symbol ▲ or ▼ is no longer highlighted!
 The startup sequence stops in phase 36 *Traveling to ignition position*.
 The ignition position can be adjusted under cold conditions.

Ignition position **P0** can only be set after symbol ▲ or ▼ is no longer highlighted.

For fuel, keep **F** depressed, for air **A**, as well as for VSD **F** and **A**

Press **-** or **+** to adjust the value.

When symbol ▲ or ▼ is no longer highlighted, the next curvepoint **P1** can be selected with **+**.

+

Phase *Traveling to ignition position*

Phase *Preignition*

Phase *1st safety time (ignition transformer ON)*

Phase *1st safety time (ignition transformer OFF), preignition time OFF*

Phase *Interval 1*

Starting the warm settings

○ ○
F or A
and

◀ ▶
- or +
as well as

○ ○
F and A
and

◀ ▶
- or +

Ignition position **P0** can only be set when symbol ▲ or ▼ is no longer highlighted.

For fuel, keep **F** depressed, for air **A**, as well as for VSD **F** and **A**

Press **-** or **+** to adjust the value.

When symbol ▲ or ▼ is no longer highlighted, the next curvepoint **P1** can be selected with **+**.

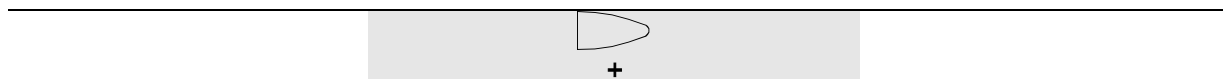

○ ○
F or A
and

◀ ▶
- or +
as well as

○ ○
F and A
and

◀ ▶
- or +

Low-flame position **P1** can only be set when symbol ▲ or ▼ is no longer highlighted.

The value is adopted from **P0**.

For fuel, keep **F** depressed, for air **A**, as well as for VSD **F** and **A**

Press **-** or **+** to adjust the value.

When symbol ▲ or ▼ is no longer highlighted, the next curvepoint **P2** can be selected with **+**.



○ ○
F or A
and

◀ ▶
- or +
as well as

○ ○
F and A
and

◀ ▶
- or +

When changing from **P1** to **P2** for the first time, curvepoints **P2...P8** automatically calculated and saved.

CALC appears for a short moment.

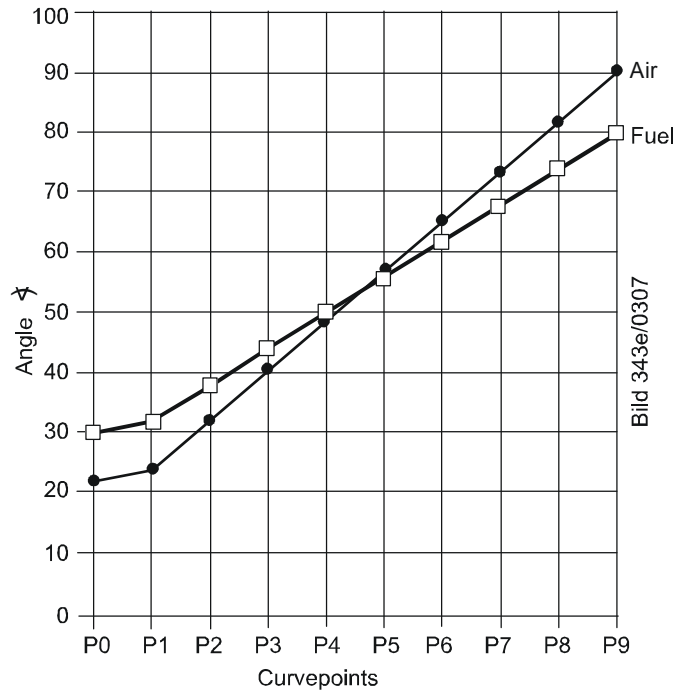

Figure 90: Setting the curvepoints



Note

Curvepoints **P2 to P8** are automatically computed as a straight line between **P1** and **P9**.

Example 1 = gas modulating

P0, P1 and P9 are set as described:	Curvepoint	Value 1 fuel	Value 2 air
	P0	30.0	22.0
	P1	32.0	24.0
	P9	80.0	90.0

P2 through P8 have automatically been calculated:	Curvepoint	Value 1 fuel	Value 2 air
	P2	38.0	32.3
	P3	44.0	40.5
	P4	50.0	48.8
	P5	56.0	57
	P6	62.0	65.3
	P7	68.0	73.5
P8	74.0	81.8	

Continue the same way with P2 through P9!

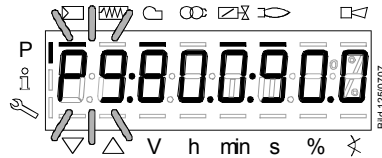
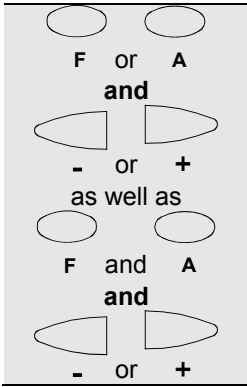

High-fire position **P9** can only be set when symbol ▲ or ▼ is no longer highlighted. If required, readjust the gas pressure.

For fuel, keep **F** depressed, for air **A**, as well as for VSD **F** and **A**

Press **-** or **+** to adjust the value. When symbol ▲ or ▼ is no longer highlighted, the next curvepoint **P8** can be selected with **-**.

After setting the high-fire point (P9), either a change to parameter 546 (automatic operation) can be made (ESC) or all curvepoints can be run through in the reverse order. If the gas pressure is changed, all curvepoints must be checked and – if required – readjusted.

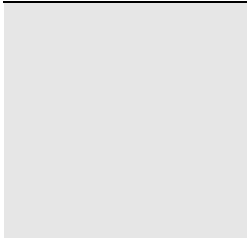
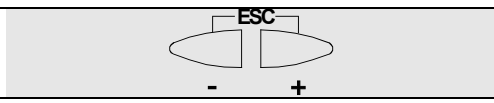

The maximum capacity is displayed. If the display shows - - - -, the maximum capacity has not yet been specified. The system can be run up to 100%.

You can press **reset** to go to editing mode, enabling you to change the maximum capacity.

To the next parameter

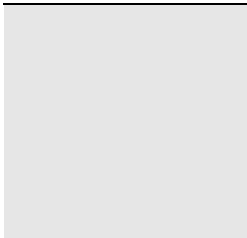

The minimum capacity is displayed. If the display shows - - - -, the minimum capacity has not yet been entered. The system can be run down to 20%.

You can press **reset** to go to editing mode, enabling you to change the minimum capacity.

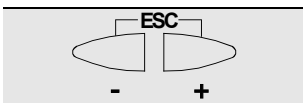

Completing parameterization of the curve

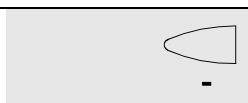

Back to the previous parameter

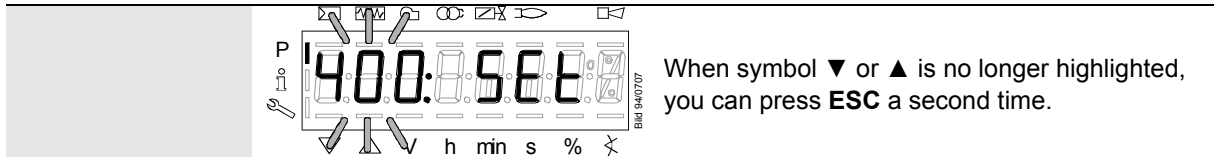

When symbol ▼ or ▲ is no longer highlighted, you can press **ESC** a second time.

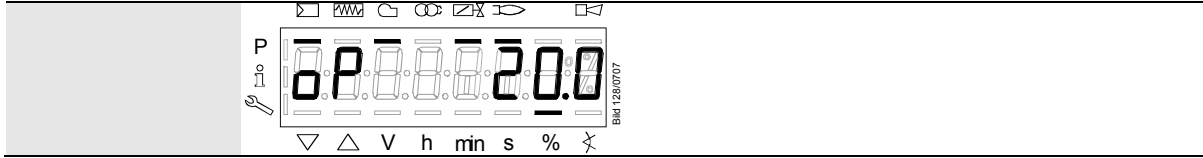
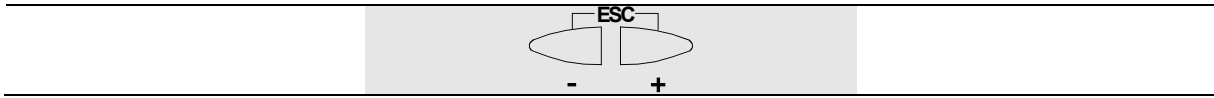

The warm settings for air-fuel ratio control by the LMV37.4... are now completed.

27.11.5 Warm settings for modulating mode («G mod pneu», «Gp1 mod pneu» and «Gp2 mod pneu»)



Note

Refer to chapter *Warm settings for modulating mode («G mod», «Gp1 mod», «Gp2 mod» and «Lo mod»)*! Here, only the air requires adjustment with **A**.

27.11.6 Cold settings for «G mod», «Gp1 mod», «Gp2 mod» and «Lo mod» and «Ho mod»



Note

Refer to chapter *Warm settings for modulating mode («G mod», «Gp1 mod», «Gp2 mod» and «Lo mod»)*! With no flame, however, no actuator travel and no automatic operation after the settings have been made.

27.11.7 Cold settings for «G mod pneu», «Gp1 mod pneu» and «Gp2 mod pneu»



Note











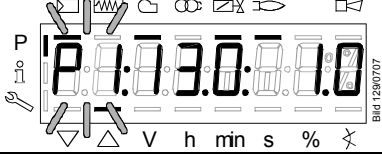

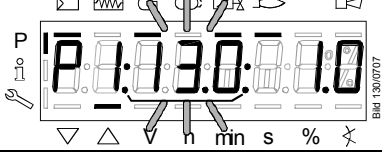

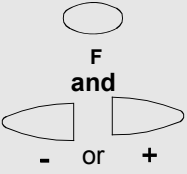
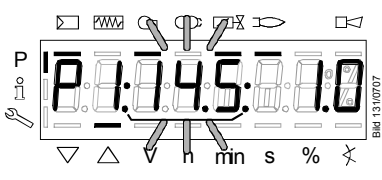



Refer to chapter *Warm settings for modulating mode («G mod», «Gp1 mod», «Gp2 mod» and «Lo mod»)*! With no flame, however, no actuator travel and no automatic operation after the settings have been made. Here, only the air requires adjustment with **A**.

27.11.8 Editing the curvepoints

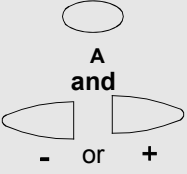
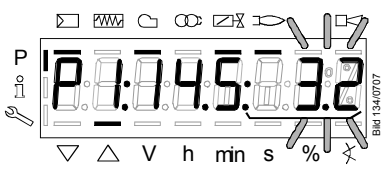

Note

To check the change on the burner, a curvepoint change in the cold settings necessitates a new approach of all curvepoints in the warm settings. After changing the curvepoint, **OFF UPr** appears on the normal display of the AZL2...

To the next curvepoint		To select the curvepoint
		The selected curvepoint is displayed.
		Keep  depressed. The fuel actuator has been selected for editing.
		Keep  depressed and press  or  to adjust the fuel actuator. In the case of warm settings, the actuator follows directly the adjustments made. The changes are saved.
		After releasing  , the curvepoint is selected again.
		Keep  depressed. The air actuator has been selected for editing.
		Keep  depressed and press  or  to adjust the air actuator. In the case of warm settings, the actuator follows directly the adjustments made. The changes are saved.
		After releasing  , the curvepoint is selected again.
To the next curvepoint		Back to the previous curvepoint

27.11.9 Interpolation of curvepoints

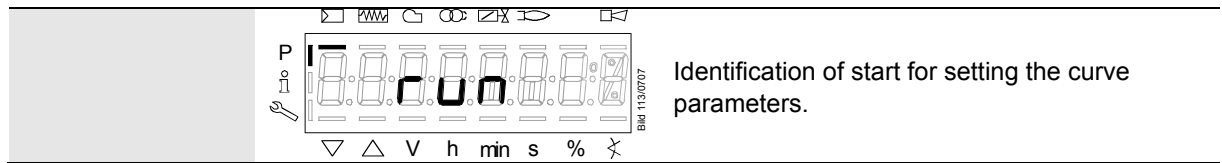
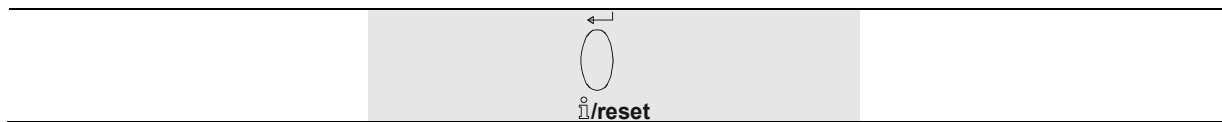

Example 1 = gas modulating

P0, P1 and P9 are set as described:	Curvepoint	Value 1 fuel	Value 2 air
	P0	30.0	22.0
	P1	32.0	24.0
	P9	80.0	90.0

P2 through P8 have automatically been calculated:	Curvepoint	Value 1 fuel	Value 2 air
	P2	38.0	32.3
	P3	44.0	40.5
	P4	50.0	48.8
	P5	56.0	57
	P6	62.0	65.3
	P7	68.0	73.5
P8	74.0	81.8	

P5 shall now be changed:

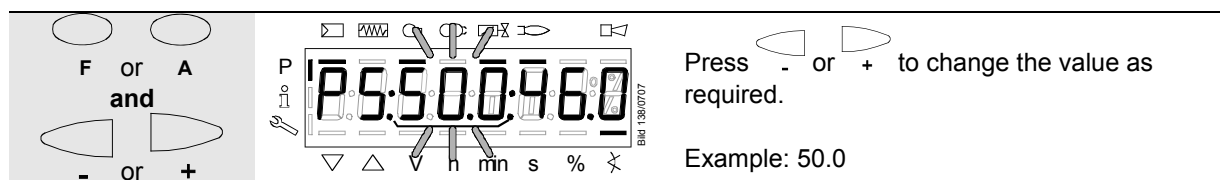
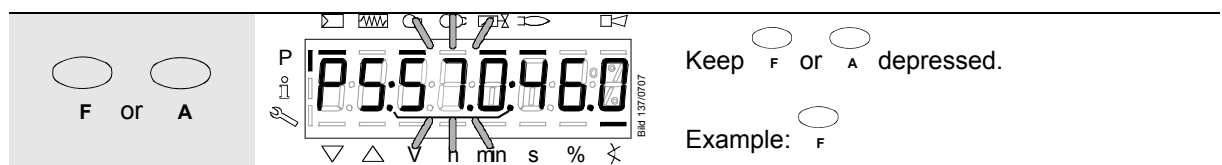
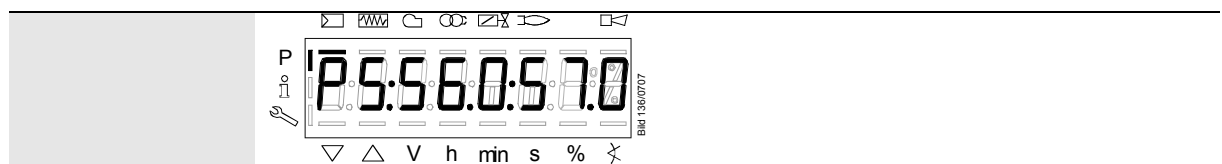
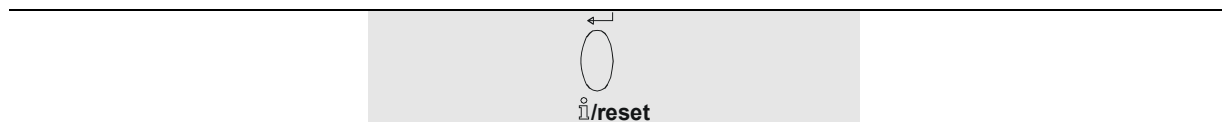

Press or to change the value as required.
 Example: **00.0**

Release or .
 The required value is adopted.
 Example: **P5:50.0:46.0**

Keep depressed for >3 s.
CALC appears.

The display jumps to **P6**.

All curvepoints from **P5** to **P9** have now been automatically recalculated (linear interpolation):

Curvepoint	Value 1 fuel	Value 2 air
P5	50.0	46.0
P6	57.5	57.0
P7	65.0	68.0
P8	72.0	79.0
P9	80.0	90.0

Keep depressed for >3 s.
CALC appears.

The display jumps to **P4**.

All curvepoints from **P1** to **P5** have now been automatically recalculated (linear interpolation):

Curvepoint	Value 1 fuel	Value 2 air
P5	50.0	46.0
P4	45.5	40.0
P3	41.0	35.0
P2	36.5	29.5
P1	32.0	24.0

>3 s +

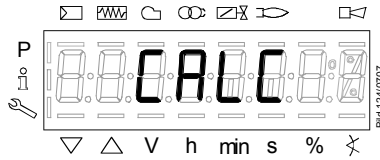

- >3 s

If it is not only the current curvepoint that shall be changed, but all other curvepoints in the direction of travel as well, a new straight line from the current curvepoint to **P9** (press +) or **P1** (press -) can be calculated by a long push on - or + .

Display **CALC**

Example of presentation

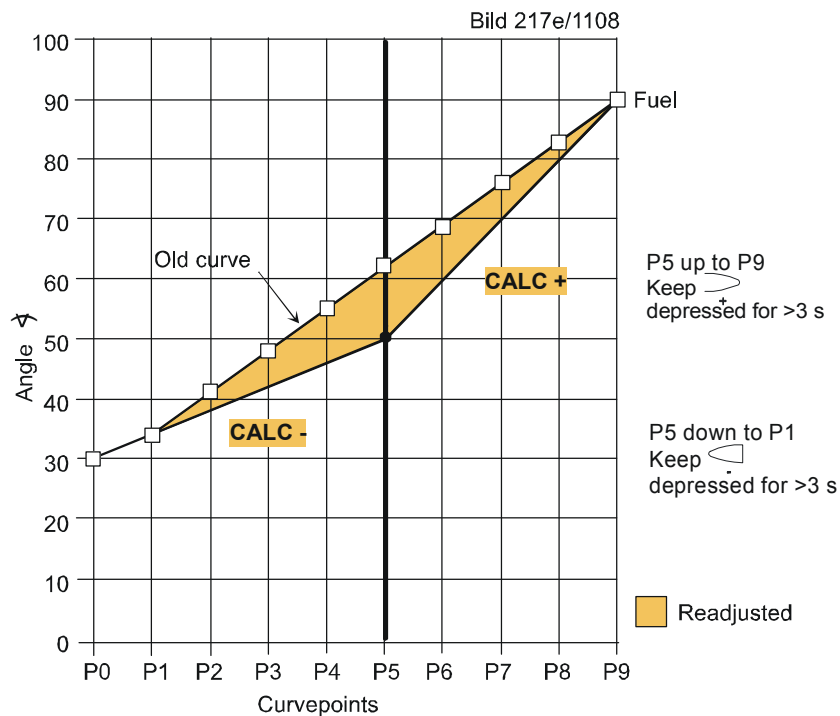

Figure 91: Changing several curvepoints











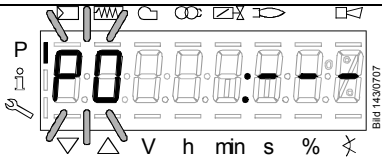

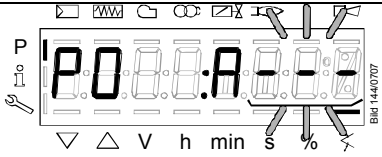

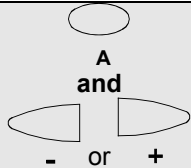
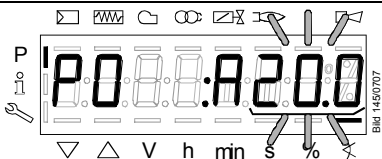

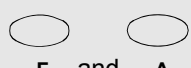
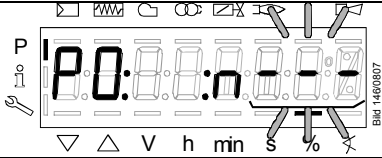

Note

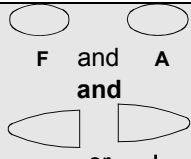
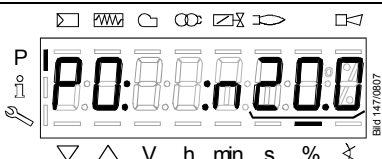
Due to interpolation, a number of curvepoints change. To be able to make a check on the burner itself, the changed curvepoints must be approached in the warm settings. If these curvepoints have not yet been completely approached, **OFF UP** appears on the normal display of the AZL2...

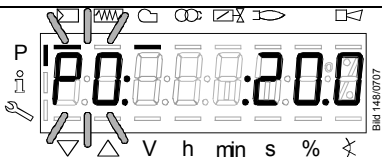

27.11.10 Setting of curvepoints for multistage mode («Lo 2-stage», «Lo 3-stage», «Ho 2-stage» and «Ho 3-stage»)

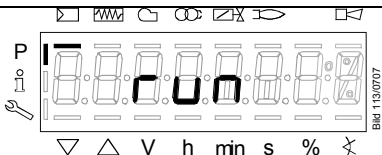
Example of «Lo 2-stage»

		P0 appears flashing. Curvepoint for ignition load.
		Keep  depressed. You are now at P0 of air actuator A .
		Press simultaneously  and  or  to adjust ignition position P0 of the air actuator. Example: 20.0
		Keep  and  depressed. You are now at n0 of the VSD.
		Press simultaneously  and  and  or  to adjust speed n0 of the VSD. Example: 20.0
		Now, release  . The selected value is adopted. Example: 20.0
		
		Identification of start for setting the curve parameters.



Note

You are now given the choice of proceeding with the warm settings by pressing  (refer to chapter *Warm settings for modulating mode «G mod», «Gp1 mod», «Gp2 mod» and «Lo mod»*), or with the cold settings by pressing  (refer to chapter *Cold settings for «G mod», «Gp1 mod», «Gp1 mod», «Gp2 mod» and «Lo mod»*).

27.11.11 Warm settings for «Lo 2-stage», «Lo 3-stage», «Ho 2-stage» and «Ho 3-stage»

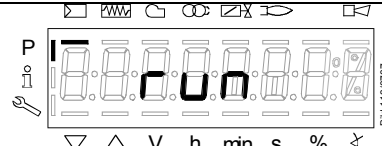

Identification of start for setting the curve parameters.

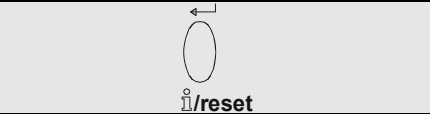

Provided the controller is enabled!



Phase *Standby* (stationary)

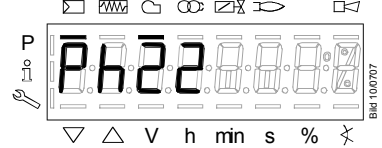

Phase *Fan ramp up* (fan motor = ON, safety valve = ON)



Phase *Traveling to prepurge position*



Phase *Prepurging*



Phase *Traveling to ignition position*

Wait until the burner is operating and symbol ▲ or ▼ is no longer highlighted!
 The startup sequence stops in phase 36 *Traveling to ignition position*.
 The ignition position can be adjusted under cold conditions.

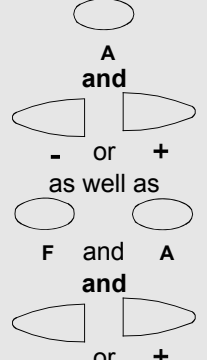
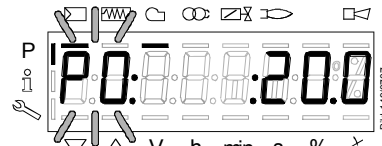



Ignition position **P0** can be set only when symbol ▲ or ▼ is no longer highlighted.

Keep **A** depressed and, for VSD **F** and **A**.

Press **-** or **+** to adjust the value.

When symbol ▲ or ▼ is no longer highlighted, the next curvepoint **P1** can be selected with **+**.



 +



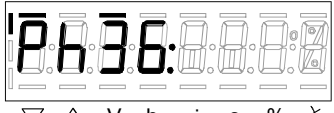

▽ ▲ V h min s % ✕

Phase *Traveling to ignition position*



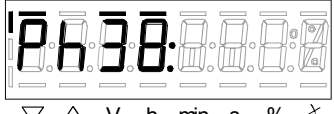

▽ ▲ V h min s % ✕

Phase *Preignition*



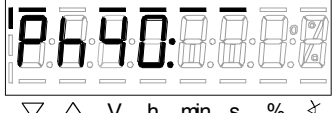

▽ ▲ V h min s % ✕

Phase *1st safety time (ignition transformer ON)*



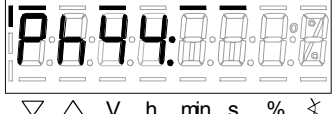

▽ ▲ V h min s % ✕

Phase *Interval 1*

○
A
and
- or +
as well as
○ ○
F and A
and
- or +

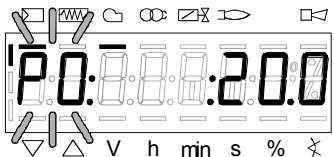

▽ ▲ V h min s % ✕

Ignition position **P0** can be set only when symbol ▲ or ▼ is no longer highlighted.

Keep ○ depressed and, for VSD ○ and ○ .

Press - or + to adjust the value.

When symbol ▲ or ▼ is no longer highlighted, the next curvepoint **P1** can be selected with ○ .



 +

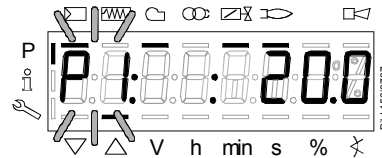
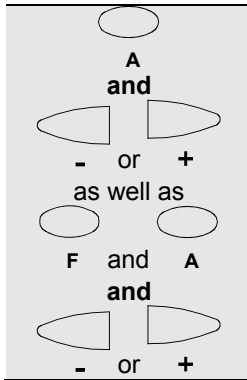

Low-fire position **P1** can be set only when symbol ▲ or ▼ is no longer highlighted. Set stage 1 **P1**. Fuel valve **V1** is switched on. Keep **A** depressed and, for VSD **F** and **A**. Press **-** or **+** to adjust the value. When symbol ▲ or ▼ is no longer highlighted, the next curvepoint **P2on** can be selected with **+**.

To the next curvepoint

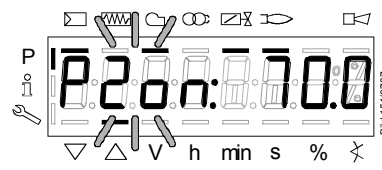
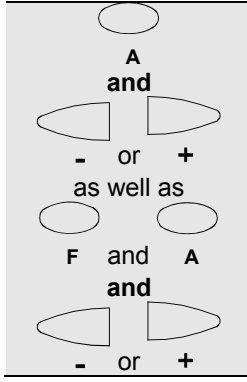

Curvepoint **P2on** can be set only when symbol ▲ or ▼ is no longer highlighted. Set switch-on point stage 2 **P2**. Fuel valve **V2** is still off. Keep **A** depressed and, for VSD **F** and **A**. Adjust the value with **-** or **+**. When symbol ▲ or ▼ is no longer highlighted, the next curvepoint **P2_d** can be selected with **+**.

To the next curvepoint



Back to the previous curvepoint

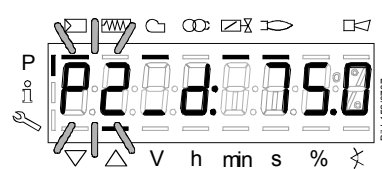
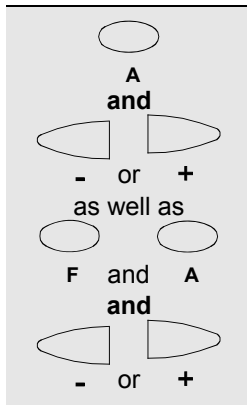

Curvepoint **P2_d** can be set only when symbol ▲ or ▼ is no longer highlighted. Fuel valve **V2** is still off and the system remains at curvepoint **P2on**. Presetting of operating stage **P2** with no travel, aimed at cutting the operating time if there is shortage of air. Keep **A** depressed and, for VSD **F** and **A**. Press **-** or **+** to adjust the value. When symbol ▲ or ▼ is no longer highlighted, the next curvepoint **P2** can be selected with **-**.

To the next curvepoint



Back to the previous curvepoint

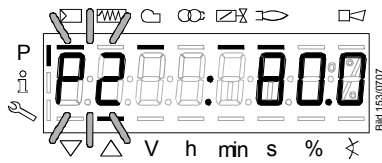
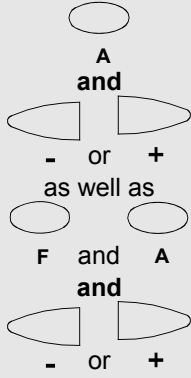

Curvepoint **P2** can only be adjusted when symbol ▲ or ▼ is no longer highlighted.

Fuel valve **V2** is switched on.

Keep **A** depressed and, for VSD **F** and **A**.

Press - or + to adjust the value.

When symbol ▲ or ▼ is no longer highlighted, the next curvepoint **P2of** can be selected with -.



Back to the previous curvepoint

Curvepoint **P2of** is now adjusted.

The system remains at P2.

Adjust the switch-off point with no travel.

Now, the curvepoint is approached dynamically when traveling from **P2** to **P1**.

When symbol ▲ or ▼ is no longer highlighted, the next curvepoint **P1** can be selected with -.

To the next curvepoint



Back to the previous curvepoint

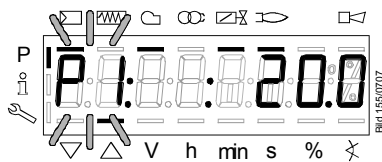

Automatic mode is released when, after reaching **P1**, the curve settings are quit with **ESC**.

If the settings are aborted earlier (**ESC** or shutdown due to fault), start prevention **OFF UP** is still active until all curvepoints are set.

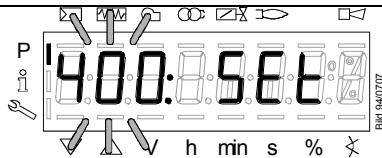
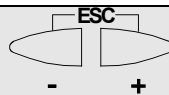

When symbol ▲ or ▼ is no longer highlighted, **ESC** can be pressed a second time.

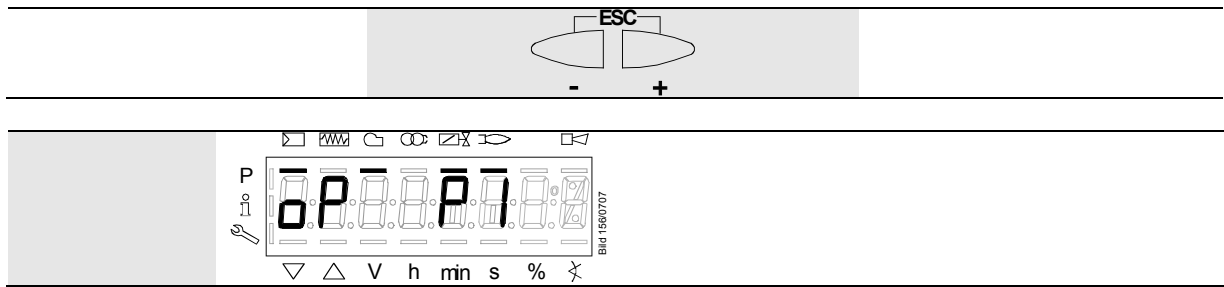

The warm settings for air-fuel ratio control of the LMV37.4... have now been configured.

27.11.12 Cold settings for multistage mode («Lo 2-stage», «Lo 3-stage», «Ho 2-stage» and «Ho 3-stage»)

Note
 Refer to chapters *Warm settings for «Lo 2-stage» and «Lo 3-stage»!* But with no flame, no actuator travel and no automatic operation after the settings have been made.

27.11.13 Intensity of flame during curve settings

When setting the curve and the curvepoint is displayed, you can press  to show the intensity of flame. When pressing the button for >1 s, a change to parameter 954 is made; when releasing the button, you return to the curvepoint.

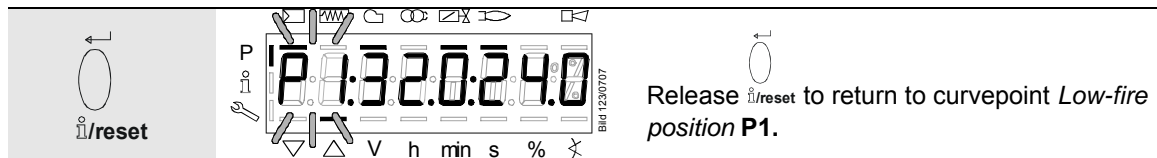
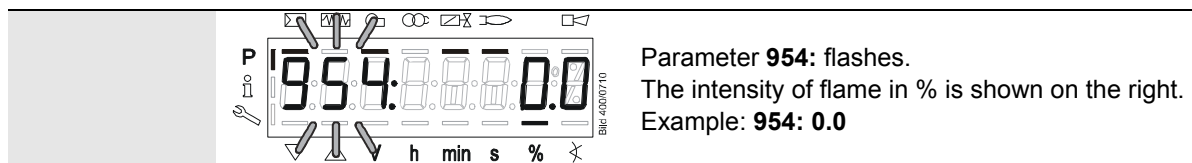
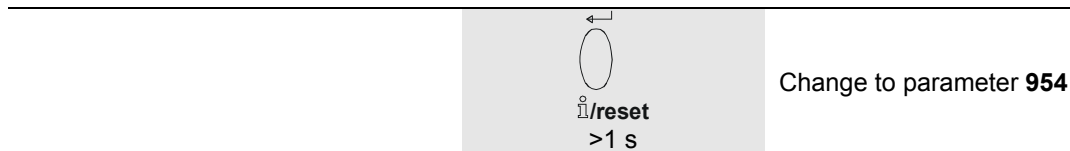
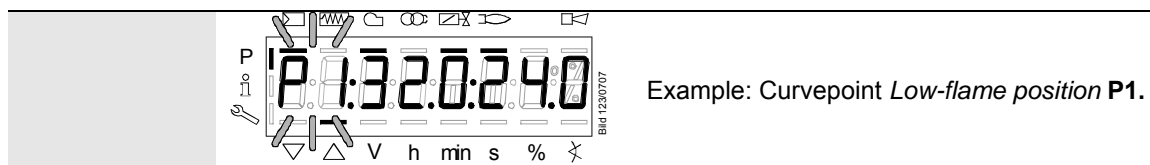

28 Parameter list LMV37.4...

Par. no.	Parameter	Number of elements	Type	Edit	Value range		Resolution	Default setting		Password level
					Min	Max				
000	Internal parameters									
041	Password heating engineer (4 characters)	1	Std_u16	edit	0	65535	1			OEM
042	OEM password (5 characters)	1	Std_u16	edit	0	65535	1			OEM
050	Start backup / restore via AZL2.../ PC software (set parameter to 1) Index 0: Create backup Index 1: Execute restore Error diagnostics via negative values (see error code 137)	2	Std_s8	edit	-99	50	1	0; 0		SO
055	Burner identification of AZL2... backup data set	1	Std_s32	read only	0	99999999	1	0		SO
056	ASN extraction of AZL2... backup data set	8	Std_u8	read only	0	127	1	0		SO
057	Software version when creating the AZL2... backup data set	1	Hex_16	read only	0x100	0xFFFF9	1	0		SO
100	General									
102	Identification date	1	Date	read only	0	255	1			Info / Service
103	Identification number	1	Std_u16	read only	0	65535	1			Info / Service
104	Preselected parameter set: Customer code	1	Std_u8	read only	0	255	1	9		Info / Service
105	Preselected parameter set: Version	1	Hex_16	read only	0	0xFFFF	1	LMV37.400...: V 01.05 LMV37.420...: V 01.06		Info / Service
107	Software version	1	Hex_16	read only	0x100	0xFFFF9	1	V 03.30		Info / Service
108	Software variant	1	Std_u8	read only	0	255	1	LMV37.400...: 1 LMV37.420...: 2		Info / Service
111	ASN extraction for verification with the AZL2... backup data set	8	Std_u8	read only	0	127	1	0		SO
113	Burner identification	1	Std_s32	edit	0	99999999	1	undefined		Info / Service Password level write: SO
121	Manual output Undefined = automatic mode	1	Output	edit / clear	0%	100%	0.1%	undefined		Info / Service
123	Minimum output positioning step Index 0: BACS output Index 1: Output of external load controller, analog Index 2: Output of external load controller contacts	3	Output	edit	0 %	100 %	0.1 %	Index 0 1 2	Value 0% 1% 0%	SO
124	Start loss-of-flame test (TÜV test) (set parameter to 1) (shutdown of fuel valves → loss of flame)	1	Std_s8	edit	-6	1	1	0		SO

Par. no.	Parameter	Number of elements	Type	Edit	Value range		Resolution	Default setting	Password level
					Min	Max			
	Error diagnostics via negative values (see error code 150)								
125	Mains frequency 0 = 50 Hz 1 = 60 Hz	1	Selection	edit	0	1	1	LMV37.400...: 0 LMV37.420...: 1	SO
126	Display brightness	1	Std_u8	edit	0%	100%	1%	LMV37.400...: 75 % LMV37.420...: 100 %	SO
127	Timeout for menu operation	1	Std_u8	edit	10 min	120 min	1 min	LMV37.400...: 30 min LMV37.420...: 60 min	OEM
128	Fuel meter: Pulse valency [pulses / volume unit]	1	Std_u16	edit	0	400	0.01	0	SO
130	Delete display of error history To delete the display: Set parameter to 1, then to 2 Return value 0: Job successfully completed Return value -1: Timeout of 1_2 sequence	1	Std_s8	edit	-5	2	1	0	SO
133	Default output for TÜV test Invalid = TÜV test when output is active 2.000...10.000 = low-fire...high-fire or stage 1 / stage 2 / stage 3	1	Output	edit / clear	20 %	100 %	0.1 %	undefined	SO
141	Operating mode BACS 0 = off 1 = Modbus 2 = reserved	1	Selection	edit	0	2	1	0	SO
142	Setback time in the event of communication breakdown Setting values 0 = inactive 1...7200 s	1	Std_u16	edit	0 s	7200 s	1 s	120 s	SO (BA)
143	Reserved	1	Std_u8	edit	1	8	1	1	Info / Service
144	Reserved	1	Std_u16	edit	10 s	60 s	1 s	30 s	SO
145	Device address for Modbus of basic unit Setting values 1...247	1	Std_u8	edit	1	247	1	1	SO
146	Setting of Baud rate for Modbus communication Setting values 0 = 9600 1 = 19200	1	Selection	edit	0	1	1	1	SO

Par. no.	Parameter	Number of elements	Type	Edit	Value range		Resolution	Default setting	Password level
					Min	Max			
147	Parity for Modbus 0 = none 1 = odd 2 = even	1	Selection	edit	0	2	1	0	SO
148	Default output if communication with building automation is interrupted Setting values: For modulation operation the setting range is as follows: 0...19.9 = burner off 20...100 = 20...100% burner rating For multistage operation apply to setting range: 0 = burner OFF, P1, P2, P3 Invalid = no default output predefined by building automation Default setting: <i>Invalid</i>	1	Output	edit / clear	0%	100%	0.1%	undefined	SO (BA)
161	Number of faults	1	Std_u16	read only	0	65535	1	0	Info / Service
162	Operating hours resettable	1	Std_s32	reset	0 h	9999999 h	1 h	0 h	Info / Service
163	Operating hours when unit is live	1	Std_s32	read only	0 h	9999999 h	1 h	0 h	Info / Service
164	Number of startups resettable	1	Std_s32	reset	0	9999999	1	0	Info / Service
166	Total number of startups	1	Std_s32	read only	0	9999999	1	0	Info / Service
167	Fuel volume resettable [m ³ , l, ft ³ , gal]	1	Std_s32	reset	0	99999999	1	0	Info / Service
176	<i>Switching back to pilot</i> switching cycles	1	Std_s32	read only	0	9999999	1	0	Info/Service
186	Software drop out delay of flame signal (100 ms) Index = = QRB... / QRC... (0 = inactive, >1) Index 1 = ION / QRA... (0 = inactive, >3 - only 200 ms-steps)	2	Std_u8	edit	0	LMV37.400...: 20 LMV37.420...: 30	1	0; 0	OEM
190	Postpurging in lockout position 0 = deactivate (no-load position) 1 = active (postpurge position) When active, the <i>Alarm in the event of start prevention</i> function is only possible to a limited extent!	1	Selection	edit	0	1	1	0	SO
191	Function <i>Switching back to pilot</i> 0 = deactivate 1 = active (low active)	1	Std_u8	edit	0	2	1	0	SO Password level write:: OEM

Par. no.	Parameter	Number of elements	Type	Edit	Value range		Resolution	Default setting	Password level
					Min	Max			
	2 = active (high active) Load controller contacts X5-03 are deactivated when function is active!								
192	Switching back to pilot minimum time	1	Time	edit	5 s	120 s	0,2 s	30 s	SO
193	Switching back to pilot maximum time	1	Time	edit	30 s	108 min.	0,2 s	60 min.	SO
194	Repetition limit no flame at the end of safety time (TSA) 1 = no repetition 2...4 = 1...3 repetitions	3	Std_u8	edit	1	2	1	0	OEM
195	Repetition limit heavy oil direct start 1 = no repetition 2...15 = 1...14 number of repetitions 16 = constant repetition	1	Std_u8	edit	1	16	1	3	SO
196	Repetition limit air pressure failure 1 = no repetition 2 = 1 repetition	1	Std_u8	edit	1	16	1	3	OEM
200	Basic unit								
201	Burner operating mode (fuel train, modulating / multistage, actuators, etc.) -- = undefined (delete curves) 1 = G mod 2 = Gp1 mod 3 = Gp2 mod 4 = Lo mod 5 = Lo 2-stage 6 = Lo 3-stage 7 = G mod pneu 8 = Gp1 mod pneu 9 = Gp2 mod pneu 10 = LoGp mod 11 = LoGp 2-stage 12 = Lo mod 2 fuel valves 13 = LoGp mod 2 fuel valves 14 = G mod pneu without actuator 15 = Gp1 mod pneu without actuator 16 = Gp2 mod pneu without actuator 17 = Lo 2-stage without actuator	1	Selection	edit / clear	1	27	1	undefined	SO

Par. no.	Parameter	Number of elements	Type	Edit	Value range		Resolution	Default setting	Password level
					Min	Max			
	18 = Lo 3-stage without actuator 19 = G mod only gas actuator 20 = Gp1 mod only gas actuator 21 = Gp2 mod only gas actuator 22 = Lo mod only oil actuator 23 = Ho mod. sep. circulation 24 = Ho 2-stage sep. circulation 25 = Ho mod. without circulation 26 = Ho 2-stage without circulation 27 = Ho 3-stage without circulation								
204	Analog output invalid (4...20 mA) 0 = default load low-fire 1 = safety shutdown + start prevention	1	Std_u8	edit	0	1	1	1	SO
205	Function <i>Load controller contacts staged</i> 0 = standard 1 = stages interchanged	1	Std_u8	edit	0	1	1	0	OEM
208	Program stop 0 = inactive 1 = PrePurgP (Ph24) 2 = IgnitPos (Ph36) 3 = interval 1 (Ph44) 4 = interval 2 (Ph52)	1	Selection	edit	0	4	1	0	SO (BA)
210	Alarm in the event of start prevention 0 = deactivated 1 = activated	1	Selection	edit	0	1	1	LMV37.400...: 0 LMV37.420...: 1	SO
211	Fan ramp up time	1	Time	edit	2 s	60 s	0.2 s	2 s	SO
212	Max. time down to low-fire	1	Time	edit	0.2 s	10 min	0.2 s	45 s	SO
213	Waiting time home run	1	Time	edit	2 s	60 s	0.2 s	2 s	OEM
214	Max. time start release	1	Time	edit	0.2 s	10 min	0.2 s	LMV37.400...: 25 s LMV37.420...: 35 s	OEM
215	Repetition limit safety loop 1 = no repetition 2...15 = 1...14 number of repetitions 16 = constant repetition	1	Std_u8	edit	1	16	1	LMV37.400...: 16 LMV37.420...: 1	SO
217	Max. waiting time for detection of a detector or pressure switch signal (e.g. home run, preignition)	1	Time	edit	5 s	10 min	0.2 s	30 s	OEM

Par. no.	Parameter	Number of elements	Type	Edit	Value range		Resolution	Default setting	Password level
					Min	Max			
221	Gas: Active detector flame evaluation 0 = QRB / QRC 1 = ION / QRA	1	Selection	edit	0	1	1	1	SO
222	Gas: Prepurging 0 = deactivated 1 = activated	1	Selection	edit	0	1	1	1	SO
223	Repetition limit gas pressure switch-min 1 = no repetition 2...15 = 1...14 number of repetitions 16 = constant repetition	1	Std_u8	edit	1	16	1	LMV37.400...: 16 LMV37.420...: 1	SO
225	Gas: Prepurge time	1	Time	edit	LMV37.400...: 20 s LMV37.420...: 5 s	60 min	0.2 s	LMV37.400...: 20 s LMV37.420...: 30 s	SO
226	Gas: Preignition time	1	Time	edit	0.4 s	60 min	0.2 s	2 s	SO
227	Gas: Safety time 1 (TSA1)	1	Time	edit	1 s	10 s	0.2 s	LMV37.400...: 3 s LMV37.420...: 5 s	OEM
229	Gas: Time to respond to pressure faults in safety time 1 (TSA1) and safety time 2 (TSA2)	1	Time	edit	0.4 s	9.6 s	0.2 s	1.8 s	OEM
230	Gas: Interval 1	1	Time	edit	0.4 s	60 s	0.2 s	2 s	SO
231	Gas: Safety time 2 (TSA2)	1	Time	edit	1 s	10 s	0.2 s	LMV37.400...: 3 s LMV37.420...: 7 s	OEM
232	Gas: Interval 2	1	Time	edit	0.4 s	60 s	0.2 s	2 s	SO
233	Gas: Afterburn time	1	Time	edit	0.2 s	60 s	0.2 s	8 s	SO
234	Gas: Postpurge time (no extraneous light test)	1	Time	edit	0.2 s	108 min	0.2 s	LMV37.400...: 0,2 s LMV37.420...: 15 s	SO
235	Gas: Air pressure switch (LP) 0 = inactive 1 = active 2 = active, except phase 60...66 (pneumatic operation only)	1	Selection	edit	1	2	1	1	SO
236	Gas: Pressure switch-min input 0 = inactive 1 = pressure switch-min (upstream of fuel valve 1 (V1)) 2 = valve proving via pressure switch-min (between fuel valves 1 (V1) and 2 (V2))	1	Selection	edit	1	2	1	1	SO
237	Gas: Pressure switch-max / POC input	1	Selection	edit	1	2	1	LMV37.400...: 1	SO

208/234

Par. no.	Parameter	Number of elements	Type	Edit	Value range		Resolution	Default setting	Password level
					Min	Max			
	0 = inactive 1 = pressure switch-max 2 = POC 3 = pressure switch valve proving							LMV37.420...: 2	
239	Gas: Forced intermittent operation 0 = inactive 1 = activated	1	Selection	edit	0	1	1	1	SO
240	Repetition limit loss of flame 1 = no repetition 2 = 1 repetition	1	Std_u8	edit	1	2	1	LMV37.400...: 2 LMV37.420...: 1	OEM
241	Gas: Execution valve proving 0 = no valve proving 1 = valve proving on startup 2 = valve proving on shutdown 3 = valve proving on startup and shutdown	1	Selection	edit	0	3	1	LMV37.400...: 2 LMV37.420...: 0	SO
242	Gas: Valve proving evacuation time	1	Time	edit	0.2 s	10 s	0.2 s	3 s	OEM
243	Gas: Valve proving time atmospheric pressure	1	Time	edit	0.2 s	60 s	0.2 s	10 s	OEM
244	Gas: Valve proving filling time	1	Time	edit	0.2 s	10 s	0.2 s	3 s	OEM
245	Gas: Valve proving time gas pressure	1	Time	edit	0.2 s	60 s	0.2 s	10 s	OEM
246	Gas: Waiting time gas shortage	1	Time	edit	0.2 s	60 s	0.2 s	10 s	OEM
248	Gas: Postpurge time (t3) (abortion with load controller (LR)-ON)	1	Time	edit	1 s	108 min	0.2 s	1 s	SO
261	Oil: Active detector flame evaluation 0 = QRB / QRC 1 = ION / QRA	1	Selection	edit	0	1	1	LMV37.400...: 0 LMV37.420...: 1	SO
262	Oil: Prepurging 0 = inactive 1 = active	1	Selection	edit	0	1	1	LMV37.400...: 0 LMV37.420...: 1	OEM
265	Oil: Prepurge time	1	Time	edit	LMV37.400...: 15 s LMV37.420...: 5 s	60 min	0.2 s	LMV37.400...: 15 s LMV37.420...: 30 s	SO
266	Oil: Preignition time	1	Time	edit	0.6 s	60 min	0.2 s	2 s	SO
267	Oil: Safety time 1 (TSA1)	1	Time	edit	1 s	15 s	0.2 s	5 s	OEM
269	Oil: Time to respond to pressure faults in safety time 1 (TSA1) and safety time 2 (TSA2)	1	Time	edit	0.4 s	14.6 s	0.2 s	1.8 s	OEM
270	Oil: Interval 1	1	Time	edit	0.4 s	60 min	0.2 s	2 s	SO

209/234

Par. no.	Parameter	Number of elements	Type	Edit	Value range		Resolution	Default setting	Password level
					Min	Max			
271	Oil: Safety time 2 (TSA2)	1	Time	edit	1 s	15 s	0.2 s	LMV37.400...: 5 s LMV37.420...: 10 s	OEM
272	Oil: Interval 2	1	Time	edit	0.4 s	60 min	0.2 s	2 s	SO
273	Oil: Afterburn time	1	Time	edit	0.2 s	60 s	0.2 s	8 s	SO
274	Oil: Postpurge time (no extraneous light test)	1	Time	edit	0.2 s	108 min	0.2 s	LMV37.400...: 0,2 s LMV37.420...: 15 s	SO
276	Oil. Pressure switch-min input 0 = inactive 1 = active from phase 38 2 = active from safety time (TSA)	1	Selection	edit	1	2	1	1	SO
277	Oil: Pressure switch-max/POC input 0 = inactive 1 = pressure switch-max 2 = POC	1	Selection	edit	1	2	1	1	SO
279	Oil: Forced intermittent operation 0 = inactive 1 = active	1	Selection	edit	0	1	1	1	SO
280	Repetition limit value loss of flame 1 = no repetition 2 = 1 repetition	1	Std_u8	edit	1	2	1	LMV37.400...: 2 LMV37.420...: 1	OEM
281	Oil: Time oil ignition 0 = short preignition (Ph38) 1 = long preignition (with fan) (Ph22)	1	Selection	edit	0	1	1	LMV37.400...: 1 LMV37.420...: 0	SO
284	Oil: Postpurge time (t3) (abortion with load controller (LR)-ON)	1	Time	edit	1 s	108 min	0.2 s	1 s	SO
286	Oil: Evaluation of heavy oil direct start 0 = only start signal in phase 38 1 = evaluation in phase 38...62	1	Selection	edit	0	1	1	1	SO
287	Oil: Maximum time heavy oil start signal	1	Time	edit	1 s	45 s	0.2 s	45 s	SO
400	Ratio curves								
401	Ratio control curve fuel actuator (only curve settings)	13	Std_s16	edit	0 °	90 °	0.1 °	0 °; 0 °; 15 °; undefined	SO
402	Ratio control curve air actuator (only curve settings)	13	Std_s16	edit	0 °	90 °	0.1 °	0 °; 90 °; 45 °; undefined	SO
403	Ratio control curve VSD (only curve settings)	13	Std_s16	edit	15 %	100%	0.1%	0%; 100%; 50%; undefined	SO
500	Ratio control								

210/234

Par. no.	Parameter	Number of elements	Type	Edit	Value range		Resolution	Default setting		Password level
					Min	Max				
501	No-flame positions fuel actuator Index 0 = home position Index 1 = prepurge position Index 2 = postpurge position	3	Std_s16	edit	0 °	90 °	0.1 °	Index 0 1 2	Value 0° 0° 15°	SO
502	No-flame positions air actuator Index 0 = home position Index 1 = prepurge position Index 2 = postpurge position	3	Std_s16	edit	0 °	90 °	0.1 °	Index 0 1 2	Value 0° 90° 45°	SO
503	No-flame speeds VSD Index 0 = no-load speed Index 1 = prepurge speed Index 2 = postpurge speed	3	Std_s16	edit	0%	100%	0.1%	Index 0 1 2	Value 0% 100% 50%	SO
522	Ramp up	1	Std_u8	edit	5 s	40 s	1 s	10 s		SO
523	Ramp down	1	Std_u8	edit	5 s	40 s	1 s	10 s		SO
542	Activation of VSD / PWM fan 0 = inactive 1 = active	1	Selection	edit	0	1	1	0		SO
544	Ramp modulating	1	Std_u8	edit	32 s	80 s	1 s	32 s		SO
545	Lower output limit undefined = 20 %	1	Output	edit / clear	20%	100%	0.1%	undefined		SO (BA)
546	Upper output limit undefined = 100 %	1	Output	edit / clear	20%	100%	0.1%	undefined		SO (BA)
600 Actuators										
601	Selection of reference point Index 0 = fuel Index 1 = air 0 = close (<0°) 1 = open (>90°)	2	Selection	edit	0	1	1	Index 0 1	Value 1 0	SO Password level write: OEM
602	Actuator's direction of rotation Index 0 = fuel Index 1 = air 0 = counterclockwise 1 = clockwise (exclusively for SQM3...)	2	Selection	edit	0	1	1	Index 0 1	Value 0 0	SO Password level write: OEM
606	Tolerance limit of position monitoring [0.1°] Index 0 = fuel	2	Std_u8	edit	0.5 °	4°	0.1 °	Index 0	Value 1.7°	SO Password level

Par. no.	Parameter	Number of elements	Type	Edit	Value range		Resolution	Default setting		Password level
					Min	Max				
	Index 1 = air Greatest position error where a fault is securely detected → error detection band: (parameter 606-0.6°) to parameter 606							1	1.7°	write: OEM
611	Type of referencing Index 0 = fuel Index 1 = air 0 = standard 1 = stop within usable range 2 = internal stop (SQN1...) 3 = both	2	Std_u8	edit	0	3	1	Index 0 1	Value 0 0	SO Password level write: OEM
613	Type of actuator Index 0 = fuel Index 1 = air 0 = 5 s / 90° (1 Nm, 1,2 Nm, 3 Nm) 1 = 10 s / 90° (6 Nm) 2 = 17 s / 90° (10 Nm)	2	Std_u8	edit	0	2	1	0; 0		SO Password level write: OEM
641	Control of speed standardization of VSD Error diagnostics of negative values (refer to error code 82) 0 = no speed standardization 1 = speed standardization active	1	Std_s8	edit	-25	1	1	0		SO
642	Standardized speed Index 0 = speed 1 Index 1 = speed 2 (internal supervision)	2	Std_u16	read only	650	6500	0.1	undefined		SO
645	Configuration of analog output 0 = DC 0...10 V 1 = DC 2...10 V 2 = DC 0/2...10 V	1	Std_u8	edit	0	2	1	0		SO
652	VSD behavior when safety loop / burner flange is open 0 = no VSD control when safety loop / burner flange is open 1 = VSD control independent of safety loop / burner flange	1	Std_u8	edit	0	1	1	1		HF
653	VSD standstill supervision in standby mode 0 = deactivate 1 = active	1	Std_u8	edit	0	1	1	1		HF
700	Error history									
701	Error history: 701-725.01.Code	25	Std_u8	read only	0	255	1	0		Info / Service

Par. no.	Parameter	Number of elements	Type	Edit	Value range		Resolution	Default setting	Password level
					Min	Max			
•	Error history: 701-725.02.Diagnostic code	25	Std_u8	read only	0	255	1	0	Info / Service
•	Error history: 701-725.03.Error class	25	Std_u8	read only	0	6	1	0	Info / Service
•	Error history: 701-725.04.Phase	25	Std_u8	read only	0	255	1	0	Info / Service
•	Error history: 701-725.05.Startup counter	25	Std_s32	read only	0	99999999	1	0	Info / Service
725	Error history: 701-725.06.Output	25	Output	read only	0%	100 %	0.1%	0%	Info / Service
900	Process data								
903	Current output Index 0 = fuel Index 1 = air	2	Output	read only	0%	100%	0.1%	0%	Info / Service
922	Incremental position of actuators Index 0 = fuel Index 1 = air	2	Std_s16	read only	-50°	150°	0.01°	0°	Info / Service
935	Absolute speed	1	Std_u16	read only	0	6553.5	0.1	0	SO
936	Standardized speed	1	Std_s16	read only	-200%	200%	0.1%	0%	Info / Service
942	Active load source 1 = output during curve settings 2 = manual output 3 = default output via building automation 4 = default output via analog input 5 = external load controller via contacts	1	Selection	read only	0	255	1	0	SO
947	Result of contact sensing (bit-coded) Bit 0.0 = 1: Pressure switch-min Bit 0.1 = 2: Pressure switch-max Bit 0.2 = 4: Pressure switch valve proving Bit 0.3 = 8: Pressure switch air pressure switch Bit 0.4 = 16: Load controller OPEN Bit 0.5 = 32: Load controller ON Bit 0.6 = 64: Load controller CLOSE Bit 0.7 = 128: Safety loop Bit 1.0 = 1: Safety valve Bit 1.1 = 2: Ignition Bit 1.2 = 4: Fuel valve 1 Bit 1.3 = 8: Fuel valve 2 Bit 1.4 = 16: Fuel valve 3 / pilot valve Bit 1.5 = 32: Reset	2	Std_u8	read only	0	255	1	0	Info / Service

Par. no.	Parameter	Number of elements	Type	Edit	Value range		Resolution	Default setting	Password level
					Min	Max			
948	Contact feedback network counter register	14	Std_u8	read only	0	255	1	0	SO
950	Required relay state (bit-coded) Bit 0 = 1: Alarm Bit 1 = 2: Safety valve Bit 2 = 4: Ignition Bit 3 = 8: Fuel valve 1 Bit 4 = 16: Fuel valve 2 Bit 5 = 32: Fuel valve 3 / pilot valve	1	Std_u8	read only	0	255	1	0	Info / Service
951	Mains voltage (normalized) AC 230 V: Voltage = value x 1.683 AC 120 V: Voltage = value x 0.843	1	Std_u8	read only	0 V	255 V	1 V	0 V	SO
954	Intensity of flame	1	Std_u8	read only	0%	100%	1%	0%	Info / Service
960	Actual flow rate (m³/h, l/h, ft³/h, gal/h)	1	Std_u16	read only	0	6553.5	0.1	0	Info / Service
961	Phase (state for external modules and display)	1	Std_u8	read only	0	255	1	0	Info / Service
981	Error memory: Code	1	Std_u8	read only	0	255	1	0	Info / Service
982	Error memory: Diagnostic code	1	Std_u8	read only	0	255	1	0	Info / Service
992	Error flags	10	Hex_32	reset	0	0xFFFFFFFF	1	0	SO

Legend

Std_u8 8 bit integer, not signed
Std_u16 16 bit integer, not signed
Std_u32 32 bit integer, not signed
Std_s8 8 bit integer, signed



Note
This data type is also used to mark an invalid or non-signed value by using the value of -1!

Std_s16 16 Bit integer, signed



Note
This data type is also used to mark an invalid or non-signed value by using the value of -1!

Std_s32 32 Bit integer, signed



Note
This data type is also used to mark an invalid or non-signed value by using the value of -1!

29 Error code list

Error code	Diagnostic code	Meaning for the LMV37.4... system	Remedy
no Comm		No communication between LMV37.4... basic unit and AZL2...	Check wiring for line interruption/loose contact
2	#	No flame at the end of the safety time (TSA)	
	1	<i>No flame at the end of safety time 1 (TSA1)</i>	
	2	<i>No flame at the end of safety time 2 (TSA2)</i>	
	4	<i>No flame at the end of safety time 1 (TSA1) (software version ≤ V02.00)</i>	
3	#	Air pressure failure	
	0	<i>Air pressure off</i>	
	1	<i>Air pressure on</i>	
	2	<i>Evaluation of air pressure</i>	Correct the setting of parameter 235 or 335 (Deactivation of the air pressure check in operation only allowed in pneumatic operation!)
	4	<i>Air pressure on – start prevention</i>	
	20	<i>Air pressure, combustion pressure – start prevention</i>	
	68	<i>Air pressure, POC – start prevention</i>	
	84	<i>Air pressure, combustion pressure, POC – start prevention</i>	
4	#	Extraneous light	
	0	<i>Extraneous light during startup</i>	
	1	<i>Extraneous light during shutdown</i>	
	2	<i>Extraneous light during startup – start prevention</i>	
	6	<i>Extraneous light during startup, air pressure – start prevention</i>	
	18	<i>Extraneous light during startup, combustion pressure – start prevention</i>	
	24	<i>Extraneous light during startup, air pressure, combustion pressure – start prevention</i>	
	66	<i>Extraneous light during startup, POC – start prevention</i>	
	70	<i>Extraneous light during startup, air pressure, POC – start prevention</i>	
	82	<i>Extraneous light during startup, combustion pressure, POC – start prevention</i>	
	86	<i>Extraneous light during startup, air pressure, combustion pressure, POC – start prevention</i>	
7	#	Loss of flame	

Error code	Diagnostic code	Meaning for the LMV37.4... system	Remedy
	0	Loss of flame	
	3	Loss of flame (software version \leq V02.00)	
	3...255	Loss of flame due to TÜV test (loss-of-flame test)	
12	#	Valve proving	
	0	Fuel valve 1 (V1) leaking (fuel valve 2 with valve proving via X5-01)	For valve proving via X5-01 (gas pressure switch-min) - Check to see if the valve on the burner side is leaking - Check to see if the pressure switch for the valve proving is closed when gas pressure is present - Check wiring to see if there is a short-circuit
	1	Fuel valve 2 (V2) leaking (fuel valve 1 with valve proving via X5-01)	For valve proving via X5-01 (gas pressure switch-min) - Check to see if the valve on the gas side is leaking - Check wiring to see if there is a short-circuit
	2	Valve proving not possible	Valve proving activated, but pressure switch-min selected as input function for X9-04 (check parameters 238 and 241)
	3	Valve proving not possible	Valve proving activated, but no input assigned (check parameters 236 and 237)
	4	Valve proving not possible	Valve proving activated, but 2 inputs assigned (set parameter 237 to pressure switch-max or POC)
	5	Valve proving not possible	Valve proving activated, but 2 inputs assigned (check parameters 236 and 237)
	81	V1 leaking	Check to see if the valve on the gas side is leaking Check wiring to see if there is an open-circuit
	83	V2 leaking	Check to see if the valve on the burner side is leaking Check to see if the pressure switch for the leakage test is closed when gas pressure is present Check wiring for short-circuit
14	#	POC	
	0	POC open	Check to see if the valve's closing contact is closed
	1	POC close	Check wiring Check to see if the valve's closing contact opens when valve is controlled
	64	POC open – prevention of startup	Check wiring to see if there is a line interruption. Check to see if the valve's closing contact is closed
19	80	Combustion pressure, POC – start prevention	Check to see if pressure switch has closed with no combustion pressure present Check wiring for short-circuit
20	#	Pressure switch-min (Pmin)	
	0	No minimum gas /oil pressure	Check wiring for line interruption
	1	Gas shortage – start prevention	Check wiring for line interruption
21	#	Pressure switch-max (Pmax) / POC	
	0	Pressure switch-max (Pmax): Max. gas / oil pressure exceeded POC: POC open (software version \leq V02.00)	Check wiring to see if there is a line interruption. POC: Check to see if the valve's closing contact is closed.
	1	POC close (software version \leq V02.00)	Check wiring.

Error code	Diagnostic code	Meaning for the LMV37.4... system	Remedy
			Check to see if the valve's closing contact opens when the valve is controlled.
	64	POC open – start prevention (software version ≤ V02.00)	Check wiring. Check whether valve's make contact opens when valve is controlled
22 OFF S	#	Safety loop / burner flange	
	0	Safety loop / burner flange open	
	1	Safety loop / burner flange open – start prevention	
	3	Safety loop/burner flange, extraneous light – start prevention	
	5	Safety loop/burner flange, air pressure – start prevention	
	17	Safety loop/burner flange, combustion pressure – start prevention	
	19	Safety loop/burner flange, extraneous light, combustion pressure – start prevention	
	21	Safety loop/burner flange, air pressure, combustion pressure – start prevention	
	23	Safety loop/burner flange, extraneous light, air pressure, combustion pressure – start prevention	
	65	Safety loop/burner flange, POC – start prevention	
	67	Safety loop/burner flange, extraneous light, POC – start prevention	
	69	Safety loop/burner flange, air pressure, POC – start prevention	
	71	Safety loop/burner flange, extraneous light, air pressure, POC – start prevention	
	81	Safety loop/burner flange, combustion pressure, POC – start prevention	
	83	Safety loop/burner flange, extraneous light, combustion pressure, POC – start prevention	
	85	Safety loop/burner flange, air pressure, combustion pressure, POC – start prevention	
	87	Safety loop/burner flange, extraneous light, air pressure, combustion pressure, POC – start prevention	
23	#	Gas pressure switch-min (Pmin) / heavy oil direct start	
	0	No minimum gas pressure	Check wiring to see if there is an open-circuit (X5-01)
	1	Gas shortage – start prevention	Check wiring to see if there is an open-circuit (X5-01)
	2	Heavy oil direct start	Check wiring to see if there is an open-circuit (X9-04)

Error code	Diagnostic code	Meaning for the LMV37.4... system	Remedy
			Check that the oil is preheated correctly
51	#	Internal error	Make a reset; if error occurs repeatedly, replace the unit
55	#	Internal error	Make a reset; if error occurs repeatedly, replace the unit
56	#	Internal error	Make a reset; if error occurs repeatedly, replace the unit
57	#	Internal error	Make a reset; if error occurs repeatedly, replace the unit
58	#	Internal error	Make a reset; if error occurs repeatedly, replace the unit
60	0	<i>Internal error: No valid output source</i>	Make a reset; if error occurs repeatedly, replace the unit
65	#	Internal error	Make a reset; if error occurs repeatedly, replace the unit
66	#	Internal error	Make a reset; if error occurs repeatedly, replace the unit
67	#	Internal error	Make a reset; if error occurs repeatedly, replace the unit
70	#	Error air-fuel ratio control: Position calculation modulating	
	23	<i>Output invalid</i>	No valid output
	26	<i>Curvepoints undefined</i>	Adjust the curvepoints for all actuators
71	#	Special position undefined	
	0	<i>Home position</i>	Parameterize the home position for all actuators used
	1	<i>Prepurge position</i>	Parameterize the prepurge position for all actuators used
	2	<i>Postpurge position</i>	Parameterize the postpurge position for all actuators used
	3	<i>Ignition position</i>	Parameterize the ignition position for all actuators used
72	#	Internal error air-fuel ratio control	Make a reset; if error occurs repeatedly, replace the unit
73	#	Internal error air-fuel control: Position calculation multistep	
	23	<i>Output invalid</i>	No valid output
	26	<i>Curvepoints undefined</i>	Adjust the curvepoints for all actuators
75	#	Internal error air-fuel ratio control: Data clocking check	
	1	<i>Current output different</i>	
	2	<i>Target output different</i>	
	4	<i>Target positions different</i>	
	16	<i>Different positions reached</i>	Can be caused by different standardized speeds (e.g. after restore of data set) when the VSD is activated → standardize again and check adjustment of the air-fuel ratio control system
76	#	Internal error air-fuel ratio control	Make a reset; if error occurs repeatedly, replace the unit
80	#	Control range limitation of VSD	<p>Basic unit could not correct the difference in speed and reached a control range limit.</p> <p>1. Basic unit is not standardized for this motor → repeat standardization.</p> <p> Caution! Settings of air-fuel ratio control must be checked!</p> <p>2. Ramp time settings of the VSD are not shorter than those of the basic unit (parameters 522,</p>

Error code	Diagnostic code	Meaning for the LMV37.4... system	Remedy
			523) or the setting for the modulating operating ramp is incorrect (parameter 544) 3. Characteristic of the VSD is not linear. Configuration of the voltage input at the VSD must accord with that of the basic unit (parameter 645). 4. VSD does not follow quickly enough the changes of the basic unit. Check settings of the VSD (input filter, slippage compensation, hiding different speeds)
	1	Control range limitation at the bottom	VSD speed was too high
	2	Control range limitation at the top	VSD speed was too low
81	1	Interrupt limitation speed input	Too much electromagnetic interference on the sensor line → improve EMC
82	#	Error during VSD's speed standardization	
	1	Timeout of standardization (VSD ramp down time too long)	Timeout at the end of standardization during ramp down of the VSD → ramp time settings of the VSD are not shorter than those of the basic unit (parameter: 523)
	2	Storage of standardized speed not successful	Error during storage of the standardized speed → lock the basic unit, then reset it and repeat the standardization
	3	Line interruption speed sensor	Basic unit receives no pulses from the speed sensor: 1. Motor does not turn. 2. Speed sensor is not connected. 3. Speed sensor is not activated by the sensor disk (check distance)
	4	Speed variation / VSD ramp up time too long / speed below minimum limit for standardization	Motor has not reached a stable speed after ramp up. 1. Ramp time settings of the VSD are not shorter than those of the basic unit (parameters 522, 523). 2. Characteristic of the VSD is not linear. Configuration of the voltage input at the VSD must accord with that of the basic unit (parameter 645). 3. VSD does not follow quickly enough the changes of the basic unit. Check settings of the VSD (input filter, slippage compensation, hiding different speeds) 4. Speed of VSD lies below the minimum for standardization (650 1/min)
	5	Wrong direction of rotation	Motor's direction of rotation is wrong. 1. Motor turns indeed in the wrong direction → change parameterization of the direction of rotation or interchange 2 live conductors. 2. Sensor disk is fitted the wrong way → turn the sensor disk.
	6	Unplausible speed sensor signals	The required pulse pattern (60°, 120°, 180°) has not been correctly identified. 1. Speed sensor does not detect all tappets of the sensor disk → check distance 2. As the motor turns, other metal parts are detected also, in addition to the tappets → improve mounting. 3. Electromagnetic interference on the sensor lines → check cable routing, improve EMC

Error code	Diagnostic code	Meaning for the LMV37.4... system	Remedy
	7	<i>Invalid standardized speed</i>	The standardized speed measured does not lie in the permissible range → motor turns too slowly or too fast
	15	<i>Speed deviation $\mu C1 + \mu C2$</i>	The speeds of microcomputer 1 and 2 deviated too much. This can be caused by wrong standardized speeds (e.g. after restoring a data set to a new unit) → repeat standardization and check the air-fuel ratio
	20	<i>Wrong phase of phase manager</i>	Standardization was made in a wrong phase. Permitted are only phases ≤ 12 → controller OFF, start standardization again
	21	<i>Safety loop / burner flange open</i>	Safety loop or burner flange is open → repeat standardization with safety loop closed
	22	<i>Air actuator not referenced</i>	Air actuator has not been referenced or has lost its referencing. 1. Check if the reference position can be approached. 2. Check if actuators have been mixed up. 3. If error only occurs after the start of standardization, the actuator might be overloaded and cannot reach its destination.
	23	<i>VSD deactivated</i>	Standardization was started with VSD deactivated → activate the VSD and repeat standardization
	24	<i>No valid operating mode</i>	Standardization was started without valid operating mode → activate valid operating mode and repeat standardization
	25	<i>Pneumatic air-fuel ratio control</i>	Standardization was started with pneumatic air-fuel ratio control → standardization with pneumatic air-fuel ratio control not possible
	128	<i>Running command with no preceding standardization</i>	VSD is controlled but not standardized → make standardization
	255	<i>No standardized speed available</i>	Motor turns but is not standardized → make standardization
83	#	Speed error VSD	Required speed has not been reached
	<i>Bit 0 Valency 1</i>	<i>Lower control range limitation</i>	Speed has not been reached because control range limitation has become active → for measures, refer to error code 80
	<i>Bit 1 Valency 2...3</i>	<i>Upper control range limitation</i>	Speed has not been reached because control range limitation has become active → for measures, refer to error code 80
	<i>Bit 2 Valency 4...7</i>	<i>Interrupt shutdown due to electromagnetic interference</i>	Speed has not been reached due to too much electromagnetic interference on the sensor line → for measures, refer to error code 81
	<i>Bit 3 Valency ≥ 8</i>	<i>Curve too steep in terms of ramp speed</i>	Check speed differential between the curvepoints and the modulating operating ramp setting (parameter 544). 1. Modulating operating ramp 32 seconds Curve slope max. 10% for LMV37.4 ramp of 20 seconds (20% for 10 seconds or 40% for 5 seconds) 2. Modulating operating ramp 48 seconds Curve slope max. 10% for LMV37.4 ramp of 30 seconds (20% for 15 seconds or 30% for 10 seconds) 3. Modulating operating ramp 64 seconds

Error code	Diagnostic code	Meaning for the LMV37.4... system	Remedy
			<p>Curve slope max. 10% for LMV37.4 ramp of 40 seconds (20% for 20 seconds or 40% for 10 seconds)</p> <p>→ Between the ignition point (P0) and the low-fire point (P1), the speed change in modulating mode may be a maximum of 40%, independent of the LMV3... ramp.</p> <p>2. The setting of the VSD ramp must be about 20% faster than the ramps in the basic unit (parameters 522, 523).</p>
	<p>Bit 4 Valency ≥ 16</p>	<p><i>Interruption of speed signal</i></p>	<p>No speed detected in spite of control.</p> <ol style="list-style-type: none"> 1. Check if the motor turns. 2. Check if the speed sensor delivers a signal (LED / check distance from the sensor disk). 3. Check wiring of the VSD.
	<p>Bit 5 Valency ≥ 32</p>	<p><i>Quick shutdown due to excessive speed deviation</i></p>	<p>Speed deviation was for about 1 s >10% outside the anticipated range.</p> <ol style="list-style-type: none"> 1. Check ramp times of the LMV37.4... and VSD. 2. Check wiring of the VSD.
84	#	Curve slope actuators	
	<p>Bit 0 Valency 1</p>	<p><i>VSD: Curve too steep in terms of ramp speed</i></p>	<p>Check speed differential between the curvepoints and the modulating operating ramp setting (parameter 544).</p> <ol style="list-style-type: none"> 1. Modulating operating ramp 32 seconds Curve slope max. 10% for LMV37.4 ramp of 20 seconds (20% for 10 seconds or 40% for 5 seconds) 2. Modulating operating ramp 48 seconds Curve slope max. 10% for LMV37.4 ramp of 30 seconds (20% for 15 seconds or 30% for 10 seconds) 3. Modulating operating ramp 64 seconds Curve slope max. 10% for LMV37.4 ramp of 40 seconds (20% for 20 seconds or 40% for 10 seconds) <p>→ Between the ignition point (P0) and the low-fire point (P1), the speed change in modulating mode may be a maximum of 40%, independent of the LMV3... ramp.</p> <p>2. Setting of the VSD ramp must be about 20% shorter than the ramps in the basic unit (parameters 522 and 523)</p>
	<p>Bit 1 Valency 2..3</p>	<p><i>Fuel actuator: Curve too steep in terms of ramp rate</i></p>	<p>Check position differential between the curvepoints and the modulating operating ramp setting (parameter 544).</p> <ol style="list-style-type: none"> 1. Modulating operating ramp 32 seconds The slope of the curve may be a maximum position change of 31° (15° for SQM33.6 and 9° for SQM33.7) between 2 curve points in modulating mode. 2. Modulating operating ramp 64 seconds The slope of the curve may be a maximum position change of 62° (30° for SQM33.6 and 18° for SQM33.7) between 2 curve points in modulating mode.
	<p>Bit 2 Valency 4..7</p>	<p><i>Air actuator: Curve too steep in terms of ramp rate</i></p>	<p>Check position differential between the curvepoints and the modulating operating ramp setting (parameter 544).</p> <ol style="list-style-type: none"> 1. Modulating operating ramp 32 seconds The slope of the curve may be a maximum position change of 31° (15° for SQM33.6 and 9° for

Error code	Diagnostic code	Meaning for the LMV37.4... system	Remedy
			SQM33.7) between 2 curve points in modulating mode. 2. Modulating operating ramp 64 seconds The slope of the curve may be a maximum position change of 62° (30° for SQM33.6 and 18° for SQM33.7) between 2 curve points in modulating mode.
85	#	<i>Referencing error ones actuators</i>	
	0	<i>Referencing error of fuel actuator</i>	Referencing of fuel actuator not successful. Reference point could not be reached. 1. Check the setting of the actuator type (parameter 613.0 or 614) 2. Check to see if actuators have been mixed up 3. Check to see if actuator is locked or overloaded
	1	<i>Referencing error of air actuator</i>	Referencing of fuel actuator not successful Reference point could not be reached. 1. Check the setting of the actuator type (parameter 613.1) 2. Check to see if actuators have been mixed up 3. Check to see if actuator is locked or overloaded
	Bit 7 Valency ≥ 128	<i>Referencing error due to parameter change</i>	Parameterization of an actuator (e.g. the reference position) has been changed. To trigger new referencing, this error is set
86	#	Error fuel actuator	
	0	<i>Position error</i>	Target position could not be reached within the required tolerance band → check to see if actuator is locked or overloaded
	Bit 0 Valency 1	<i>Line interruption</i>	Line interruption detected at actuator's terminals → check wiring (voltage X54 across pin 5 or 6 and pin 2 >0.5 V)
	Bit 3 Valency ≥ 8	<i>Curve too steep in terms of ramp rate</i>	Check position differential between the curvepoints and the modulating operating ramp setting (parameter 544). 1. Modulating operating ramp 32 seconds The slope of the curve may be a maximum position change of 31° (15° for SQM33.6 and 9° for SQM33.7) between 2 curve points in modulating mode. 2. Modulating operating ramp 64 seconds The slope of the curve may be a maximum position change of 62° (30° for SQM33.6 and 18° for SQM33.7) between 2 curve points in modulating mode.
	Bit 4 Valency ≥ 16	<i>Step deviation in comparison with last referencing</i>	Actuator was overloaded or mechanically twisted. 1. Check the setting of the actuator type (parameter 613.0 or 614) 2. Check to see if the actuator is blocked somewhere along its working range. 3. Check to see if the torque is sufficient for the application.
87	#	Error air actuator	
	0	<i>Position error</i>	Target position could not be reached within the required tolerance band → check to see if actuator is locked or overloaded
	Bit 0	<i>Line interruption</i>	Line interruption detected at actuator's terminals

Error code	Diagnostic code	Meaning for the LMV37.4... system	Remedy
	<i>Valency 1</i>		→ check wiring (voltage X53 across pin 5 or 6 and pin 2 >0.5 V)
	<i>Bit 3 Valency ≥ 8</i>	<i>Curve too steep in terms of ramp rate</i>	Check position differential between the curvepoints and the modulating operating ramp setting (parameter 544). 1. Modulating operating ramp 32 seconds The slope of the curve may be a maximum position change of 31° (15° for SQM33.6 and 9° for SQM33.7) between 2 curve points in modulating mode. 2. Modulating operating ramp 64 seconds The slope of the curve may be a maximum position change of 62° (30° for SQM33.6 and 18° for SQM33.7) between 2 curve points in modulating mode.
	<i>Bit 4 Valency ≥ 16</i>	<i>Sectional deviation in comparison with last referencing</i>	Actuator was overloaded or mechanically twisted. 1. Check the setting of the actuator type (parameter 613.1) 2. Check to see if the actuator is blocked somewhere along its working range. 3. Check to see if the torque is sufficient for the application.
90	#	Internal error basic unit	
91	#	Internal error basic unit	
93	#	Error flame signal acquisition	
	3	<i>Short-circuit of sensor</i>	Short-circuit at QRB... 1. Check wiring. 2. Flame detector possibly fault.
95	#	Error relay supervision	
	<i>3 Ignition transformer 4 Fuel valve 1 5 Fuel valve 2 6 Fuel valve 3</i>	<i>External power supply active contact</i>	Check wiring
96	#	Error relay supervision	
	<i>3 Ignition transformer 4 Fuel valve 1 5 Fuel valve 2 6 Fuel valve 3</i>	<i>Relay contacts have welded</i>	Test the contacts: 1. Unit connected to power: Fan output must be dead. 2. Disconnect power: Disconnect fan. No resistive connection between fan output and neutral conductor allowed. If one of the 2 tests fails, release the unit since contact have definitively welded and safety can no longer be ensured.
97	#	Error relay supervision	
	0	<i>Safety relay contacts have welded or external power supply fed to safety relay</i>	Test the contacts: 1. Unit connected to power: Fan output must be dead. 2. Disconnect power: Disconnect fan. No resistive connection between fan output and neutral conductor allowed. If one of the 2 tests fails, release the unit since contacts have definitively welded and safety can no longer be ensured.

Error code	Diagnostic code	Meaning for the LMV37.4... system	Remedy
98	#	Error relay supervision	
	2 Safety valve 3 Ignition transformer 4 Fuel valve 1 5 Fuel valve 2 6 Fuel valve 3	Relay does not pull in	Make a reset; if error occurs repeatedly, replace the unit
99	#	Internal error relay control	Make a reset; if error occurs repeatedly, replace the unit
	3	Internal error relay control	Make a reset. If error occurs repeatedly, replace the unit Software version V03.10: If error C:99 D:3 occurs during standardization of the VSD, deactivate temporarily function <i>Alarm in case of start prevention</i> (parameter 210 = 0, when using a release contact) or <i>interrupt</i> the controller-ON signal
100	#	Internal error relay control	Make a reset; if error occurs repeatedly, replace the unit
105	#	Internal error contact sampling	
	0 Pressure switch min 1 Pressure switch max / POC 2 Pressure switch valve proving 3 Air pressure 4 Load controller open 5 Load controller on / off 6 Load controller close 7 Safety loop / Burner flange 8 Safety valve 9 Ignition transformer 10 Fuel valve 1 11 Fuel valve 2 12 Fuel valve 3 13 Reset	Stuck-At failure	Can be caused by capacitive loads or supply of DC voltage to the mains voltage inputs. The diagnostic code indicates the input where the problem occurred
106	#	Internal error contact request	Make a reset; if error occurs repeatedly, replace the unit
107	#	Internal error contact request	Make a reset; if error occurs repeatedly, replace the unit
108	#	Internal error contact request	Make a reset; if error occurs repeatedly, replace the unit
110	#	Internal error voltage monitor test	Make a reset; if error occurs repeatedly, replace the unit
111	#	Mains undervoltage	Mains voltage to low Conversion factor diagnostic code → voltage value (AC 230 V: 1,683; AC 120 V: 0,843)
112	0	Mains voltage recovery	Error code for triggering a reset on power restoration (no error)
113	#	Internal error mains voltage supervision	Make a reset; if error occurs repeatedly, replace the unit
115	#	Internal error system counter	
116	0	Designed lifecycle exceeded (250,000 startups)	Warning threshold has been reached. The unit should be replaced
117	0	Life time exceeded	Switch-off threshold has been reached

224/234

Error code	Diagnostic code	Meaning for the LMV37.4... system	Remedy
		<i>Operation no longer allowed</i>	
120	0	<i>Interrupt limitation fuel counter input</i>	Too many disturbance pulses at the fuel meters input → Improve EMC
121	#	Internal error EEPROM access	Make a reset, repeat last parameterization / check. Restore the parameter set, if error occurs repeatedly, replace the unit
122	#	Internal error EEPROM access	Make a reset, repeat last parameterization / check. Restore the parameter set, if error occurs repeatedly, replace the unit
123	#	Internal error EEPROM access	Make a reset, repeat last parameterization / check. Restore the parameter set, if error occurs repeatedly, replace the unit
124	#	Internal error EEPROM access	Make a reset, repeat last parameterization / check. Restore the parameter set, if error occurs repeatedly, replace the unit
125	#	Internal error EEPROM read access	Make a reset, repeat last parameterization / check. If error occurs repeatedly, replace the unit
126	#	Internal error EEPROM write access	Make a reset, repeat last parameterization / check. If error occurs repeatedly, replace the unit
127	#	Internal error EEPROM access	Make a reset, repeat last parameterization / check. Restore the parameter set, if error occurs repeatedly, replace the unit
128	0	<i>Internal error EEPROM access - synchronization during initialization</i>	Make a reset; if error occurs repeatedly, replace the unit
129	#	Internal error EEPROM access – command synchronization	Make a reset, repeat last parameterization / check. If error occurs repeatedly, replace the unit
130	#	Internal error EEPROM access - timeout	Make a reset, repeat last parameterization / check. If error occurs repeatedly, replace the unit
131	#	Internal error EEPROM access - page on abort	Make a reset, repeat last parameterization / check. If error occurs repeatedly, replace the unit
132	#	Internal error EEPROM register initialization	Make a reset; if error occurs repeatedly, replace the unit
133	#	Internal error EEPROM access – Request synchronization	Make a reset, repeat last parameterization / check. If error occurs repeatedly, replace the unit
134	#	Internal error EEPROM access – Request synchronization	Make a reset, repeat last parameterization / check. If error occurs repeatedly, replace the unit
135	#	Internal error EEPROM access – Request synchronization	Make a reset, repeat last parameterization / check. If error occurs repeatedly, replace the unit
136	#	Restore	
	1	<i>Restore started</i>	Restore of a backup has been started (no error) New devices require resetting following restore!
		for further diagnostic codes for error code 136, refer to error code 137	For measures, refer to error code 137
137	#	Internal error – backup / restore	
	157 (-99)	<i>Restore – ok, but backup < data set of current system</i>	Restore successful, but backup data set is smaller than in the current system
	239 (-17)	<i>Backup – storage of backup in AZL2... faulty</i>	Make reset and repeat backup
	240 (-16)	<i>Restore – no backup in AZL2...</i>	No backup in AZL2...

Error code	Diagnostic code	Meaning for the LMV37.4... system	Remedy
	241 (-15)	Restore – interruption concerning unpassable ASN	The Backup has a unpassable ASN and may not restore of the unit
	242 (-14)	Backup – backup made is inconsistent	Backup is faulty and cannot be transferred back
	243 (-13)	Backup – data comparison between μ Cs faulty	Repeat reset and backup
	244 (-12)	Backup data are incompatible	Backup data are incompatible with the current software version, restore not possible
	245 (-11)	Access error to parameter Restore_Complete	Repeat reset and backup
	246 (-10)	Restore – timeout when storing in EEPROM	Repeat reset and backup
	247 (-9)	Data received are inconsistent	Backup data set invalid, restore not possible
	248 (-8)	Restore cannot at present be made	Repeat reset and backup
	249 (-7)	Restore – abortion due to unsuitable burner identification	Backup has an unsuitable burner identification and must not be transferred to the unit
	250 (-6)	Backup – CRC of one page is not correct	Backup data set invalid, restore not possible
	251 (-5)	Backup – burner identification is not defined	Define burner identification and repeat backup
	252 (-4)	After restore, pages still on ABORT	Repeat reset and backup
	253 (-3)	Restore cannot at present be made	Repeat reset and backup
	254 (-2)	Abortion due to transmission error	Repeat reset and backup
	255 (-1)	Abortion due to timeout during restore	Make a reset, check the connections and repeat the backup
146	#	Timeout building automation interface	Refer to User Documentation Modbus (A7541)
	1	Modbus timeout	
150	#	TÜV test	
	1 (-1)	Invalid phase	TÜV test may only be started in phase 60 (operation)
	2 (-2)	TÜV test default output too low	TÜV test default output must be lower than the lower output limit
	3 (-3)	TÜV test default output too high	TÜV test default output must be higher than the upper output limit
	4 (-4)	Manual abortion	No error: Manual abortion of TÜV test by the user
	5 (-5)	TÜV test timeout	No loss of flame after fuel valves have been shut 1. Check for extraneous light 2. Check wiring for short-circuit 3. Check to see if one of the valves is leaking
165	#	Internal error	
166	0	Internal error watchdog reset	
167	#	Manual locking	Unit has been manually locked (no error)
	1	Manual locking by contact	
	2	Manual locking by AZL2...	
	3	Manual locking by PC software	
	8	Manual locking by the AZL2... Timeout / communication breakdown	During a curve adjustment via the AZL2..., the timeout for menu operation has elapsed (setting via parameter 127), or communication between the LMV37.4... and the AZL2... has broken down
	9	Manual locking by the PC software Communication breakdown	During a curve adjustment via the ACS410, communication between the LMV37.4... and the ACS410 was interrupted for more than 30 seconds
	33	Manual locking after PC software	PC software made a reset attempt although the system worked correctly

Error code	Diagnostic code	Meaning for the LMV37.4... system	Remedy
		<i>reset attempt</i>	
168	#	Internal error management	Make a reset; if error occurs repeatedly, replace the unit
169	#	Internal error management	Make a reset; if error occurs repeatedly, replace the unit
170	#	Internal error management	Make a reset; if error occurs repeatedly, replace the unit
171	#	Internal error management	Make a reset; if error occurs repeatedly, replace the unit
200 OFF	#	System error-free	No error
201 OFF UPr	#	Start prevention	Start prevention due to unparameterized unit Go to error history, entry 702, for initial cause of the error with shutdown in connection with the first curve settings
	<i>Bit 0 Valency 1</i>	<i>No operating mode selected</i>	
	<i>Bit 1 Valency 2..3</i>	<i>No fuel train defined</i>	
	<i>Bit 2 Valency 4..7</i>	<i>No curves defined</i>	
	<i>Bit 3 Valency 8..15</i>	<i>Standardized speed undefined</i>	
	<i>Bit 4 Valency 16..31</i>	<i>Backup / restore was not possible</i>	
202	#	Internal error operating mode selection	Redefine the operating mode (parameter 201)
203	#	Internal error	Redefine the operating mode (parameter 201). Make a reset; if error occurs repeatedly, replace the unit
204	Phase number	Program stop	Program stop is active (no error)
205	#	Internal error	Make a reset; if error occurs repeatedly, replace the unit
206	0	<i>Inadmissible combination of units (basic unit - AZL2...)</i>	
207	#	Version compatibility basic unit - AZL2...	
	0	<i>Basic unit version too old</i>	
	1	<i>AZL2... version too old</i>	
208	#	Internal error	Make a reset; if error occurs repeatedly, replace the unit
209	#	Internal error	Make a reset; if error occurs repeatedly, replace the unit
210	0	<i>Selected operating mode is not released for the basic unit</i>	Select a released operating mode for the basic unit
240	#	Internal error	Make a reset; if error occurs repeatedly, replace the unit
245	#	Internal error	Make a reset; if error occurs repeatedly, replace the unit
250	#	Internal error	Make a reset; if error occurs repeatedly, replace the unit

30 Revision history of basic unit LMV37.4...

Software changes

Software version V01.20

- Optimizations regarding ACS410 (backup / restore)
- Faster parameterization with AZL2... (3-stage)
- Burner identification setting (entering the password)
- Optimization: System hooks itself up in phase 38
- Optimization: Cold setting via P0 (adoption P0 → P1, correct CALC function)
- Optimization: Delete history (acknowledgement upon completion)
- Prepurging oil – activated / deactivated (parameter 262) for OEM level released
- Setting range of pulse valency fuel meter (parameter 128) increased to 400 pulses per volume unit
- New parameter 645 = configuration analog output

Software version V01.30

- Optimization of phase manager (rectification of error 107)
- Presetting of parameter 281 (time oil ignition) changed to long preignition (with fan)

Software version V01.40

- Optimization: Modbus mode and operating mode are maintained when a reset is made
- Extension: Additional Modbus addresses (refer to Modbus Documentation A7541)
- Extension: Actuator tolerance can be parameterized by OEM and read by the heating engineer
- Change: The heating engineer can set the time when valve proving takes place
- Extension: Calculation of fuel throughput
- Optimization: Plausibility check for continuous operation with ionization amplifier
- Optimization: Separate diagnostic code in the event standardization has not been successful due to an undefined operating mode
- Optimization: Change of password without having to enter the currently valid password
- Extension: Restore of data set possible only when type references of basic unit and data set are identical
- Optimization: Alarm in the event of start prevention after a fixed time of 5 seconds
- Extension: Selection of POC function or Pmax

Software version V01.60

- Optimization: Filtering of analog power output
- Optimization: Plausibility check of ionization amplifier revised

Software version V01.70

Optimization: Final test sequence revised

Software version V01.80

- Optimization: Valve proving during shutdown after display error in operation
- Optimization: Any valve proving aborted by P_{min} during shutdown is repeated with the next startup

Software version V01.90

- Scaling of analog input changed (no *burner OFF* function)
- Optimization: Variable step width between ignition and low-fire (40% difference in speed, independent of ramp time; traveling time varies between 4 and 16 seconds with a 5- to 20-second ramp)
- Optimization: Checking the standardized speed between microcomputer 1 and microcomputer 2 (wrong standardized speeds after restore)
Objective: Avoiding wrong standardized speeds after restore to new hardware resulting from resonator tolerances of the 2 microcomputers
- Revision of standardization of VSD signal in terms of control and evaluation of errors
- Optimization: Curve adjustment with pneumatic air-fuel ratio control. Here, the curve can be adjusted with no need for making the standardization beforehand of VSD
- Optimization: Parameter access when firing on oil
- Optimization: Assessment of P_{min} in phase 62

Software version V2.00

- Correction to fuel train Gp1: Safety time 1 was up to 0.4 seconds too long
- Correction to fuel train Gp1: Evaluation of pressure switches in phases 40 to 50 (P_{min} / P_{max} were not valued in phase 44, P_{min} / P_{max} were evaluated in phase 50 although the main valve was switched on)
- First error reception for gas shortage with first setting (gas shortage error was exceeded with first setting of *OFF UPr* – both errors occur in the same cycle)
- Timeout (parameter 127) or communication breakdown with the AZL2... leads to lockout during the time the curves are set (error code: 167, diagnostics: 8)
→ with cold setting, no startup on completion of the password time
- Communication breakdown with the ACS410 (30 seconds) leads to lockout during the time the curves are set (error code: 167, diagnostics 9)

Software version V02.90

- Optimization: Indication of errors on the parameter and info / service menu
- Optimization: Rectification of eBus error telegrams, correction of manufacturer's code for safety limit thermostat, extension of service data interrogation PB:03h SB:10h by the meter readings of the second fuel, PB:05h SB:09h shows the fuel currently burnt
- Optimization: Curve setting invalid (OFF UPr) upon change to cold settings
- Optimization: Setting of minimum / maximum output via the parameterized output
- Optimization: Shorter startup time with valve proving (prepurge or postpurge time simultaneously with valve proving)
- New function: Loss-of-flame test (TÜV test), forced shutdown of fuel valves
- Extension: Oil pressure switch-min active from phase 38 or safety time (phase 40)
- Extension: Setting of dead band zone for load controller contacts, analog input and BACS output
- Extension: POC for firing on oil (alternative to pressure switch-max)
- New function: Valve proving via pressure switch-min
- New function: Abortion of postpurging (see postpurge time, extraneous light test in phase 78)
- New function: Evaluation of load controller contacts for multistage operation (normal / interchanged)
- New fuel trains LO Gp, LO-2V, LO Gp-2V
- New operating modes (e.g. without actuator)
- New function: Backup / restore via AZL2... (only with new software version AZL2...)

Software version V03.00

Optimization: Maximum time of safety phase reduced from 28 to 27 seconds

Software version V03.10

- Optimization: If power supply fails during the restore process, the data set can be repaired by starting a new restore process (since the backup / restore option is not yet available with V03.00 because there is no suitable AZL2..., this effect cannot occur)
- Optimization: When making a reset via the AZL2..., an *incomplete* reset occurred in very rare cases (display showed *RESEt*, but reset was not triggered)
- Optimization: The time ascertained by the loss-of-flame test was 0.2 seconds too long
- Optimization: Reduced detection of undervoltage when fan motor is started in phase 22 (when a single-phase motor and the LMV3 were powered via the same phase, undervoltage detection could occur on startup; in that case, the LMV3 system was not operated as specified)
- Optimization: Better overview through text changes of groups 200 = PAr0, 300 = PAr1 and 600 = ACtr on the parameter menu (initially PArA), and hiding of unused parameters after selection of fuel train/operating mode
- Optimization: Control of the fan output during standardization (standby) for using a release contact via an external relay at the fan's output
- Optimization: Curve setting invalid (OFF UPr) after new / further standardization
- Optimization: To shorten the startup time, there is no referencing when postpurging is aborted via controller-ON (direct start)
- Automatic return travel of the SQN1... at the lower internal stop
- Parameter on Siemens level
Longer ignition off time during safety time 1 (TSA1) (increased from 0.4 to 0.6 seconds) to prevent wrong error diagnostics in connection with QRA2... (C:7 in place of C:2)

Software version V03.30

- Extension: Display of intensity of flame when setting the curves
- Optimization: Display and diagnostics of changing start preventions
- Optimization: No unplausible relay setpoint (error C:99 D:3) when starting standardization, alarm in case of start prevention and controller-ON signal
- Optimization: No VSD standardization with pneumatic air-fuel ratio control
- Optimization: Referencing in connection with direction of rotation *Right* and home position 90°

Software version V03.40

- Extension: Supports SQM33.6 or SQM33.7
- Extension: Purging in the lockout position
- Extension: Heavy oil operating modes
- Optimization: Shutdown of VSD control when burner flange / safety loop is open
- Optimization: Minimum setting for prepurge time: 5 seconds
- Extension: *Switching back to pilot* function
- Optimization: Standstill supervision of the VSD can be switched off in standby mode
- Extension: *No flame at the end of safety time* TSA repetition counter, adjustable *air pressure failure* (OEM), heavy oil direct start (SO)
- Extension: Air pressure supervision in operation with pneumatic ratio control can be switched off (OEM)
- Extension: VSD ramp time increased to 40 seconds
- Extension: Modbus data points
127 = Fuel 0 operating mode (parameter 201)
128 = Fuel 1 operating mode (parameter 301)
129 = *Switching back to pilot* cycle counter (parameter 176)

31 List of figures

Figure 1: Note on mounting	11
Figure 2: Electrical connection.....	13
Figure 3: System structure	19
Figure 4: Ionization input at AC 120 V / AC 230 V	26
Figure 5: QRB... input at AC 120 V / AC 230 V	29
Figure 6: Dimension LMV37.4... ..	31
Figure 7: Flame signal input X10-05	33
Figure 8: Flame signal input X10-06	33
Figure 9: Safety loop X3-04	37
Figure 10: Burner flange X3-03.....	38
Figure 11: Inputs for external load controller ON / OFF X5-03	38
Figure 12: Inputs external load controller Open / Close X5-03	38
Figure 13: Air pressure switch (APS) X3-02	39
Figure 14: Pressure switch valve proving gas (P LT) X9-04	40
Figure 15: Gas pressure switch-min (Pmin) X5-01	42
Figure 16: Gas / oil pressure switch-max (Pmax) or POC X5-02.....	44
Figure 17: Reset X8-04	46
Figure 18: Output alarm X3-05	47
Figure 19: Fan motor contactor X3-05	47
Figure 20: Continuous fan operation X3-05	47
Figure 21: Output ignition (Z) X4-02	48
Figure 22: Output fuel valve (V1) X8-02	49
Figure 23: Output fuel valve (V2) X7-01	49
Figure 24: Output fuel valve (V3) / pilot valve (PV) X7-02	49
Figure 25: Output safety valve (SV) X6-03	49
Figure 26: Output for indication of operation X8-04	49
Figure 27: Message in the case of program stop.....	61
Figure 28: Continuous fan.....	62
Figure 29: Application example of purging in the lockout position with fan but without VSD	64
Figure 30: Application example of purging in the lockout position with fan and VSD release contact	64
Figure 31: Wiring LMV37... with universal controller RWF55... ..	66
Figure 32: Switching back to pilot sequence in connection with an RWF40 / RWF55 controller	66
Figure 33: Gas direct ignition	68

Figure 34: Gas pilot ignition 1	68
Figure 35: Gas pilot ignition 2	68
<i>Figure 36: Gas – fuel valve control - program</i>	<i>69</i>
Figure 37: Light oil direct ignition, multistage	70
Figure 38: Light oil direct ignition, 2-stage	70
Figure 39: Light oil direct ignition, 3-stage	70
Figure 40: Light oil direct ignition, modulating	71
Figure 41: Light oil ignition, modulating	71
<i>Figure 42: Oil direct ignition - fuel valve control - program</i>	<i>71</i>
Figure 43: Light oil direct ignition, modulating, without shutdown facility for adjustable head	72
Figure 44: Light oil direct ignition, modulating, with shutdown facility for adjustable head	72
<i>Figure 45: Light oil direct ignition – fuel valve control – program</i>	<i>72</i>
<i>Figure 46: Light oil with gas pilot ignition</i>	<i>73</i>
<i>Figure 47: Light oil with gas pilot ignition – fuel valve control - program</i>	<i>73</i>
<i>Figure 48: Light oil with gas pilot ignition</i>	<i>74</i>
<i>Figure 49: Light oil with gas pilot ignition – fuel valve control - program</i>	<i>74</i>
<i>Figure 50: Heavy oil direct ignition, 2-stage, with circulation control</i>	<i>75</i>
<i>Figure 51: Heavy oil direct ignition, modulating, with circulation control</i>	<i>75</i>
<i>Figure 52: Heavy oil direct ignition – fuel valve control - program</i>	<i>76</i>
Figure 53: Program for gas direct ignition «G», «G mod», «G mod pneu»	78
Figure 54: Program for gas pilot ignition «Gp1», «Gp1 mod», «Gp1 mod pneu»	79
Figure 55: Program for gas pilot ignition «Gp2», «Gp2 mod», «Gp2 mod pneu»	80
Figure 56: Program for light oil «Lo», «Lo mod», «Lo 2-stage», «Lo 3-stage»	81
Figure 57: Program light oil pilot ignition (Lo Gp)	82
Figure 58: Program Heavy oil direct ignition «HO», «HO m. Umsp mod», «HO m. Umsp 2-stage»	83
Figure 59: Program heavy oil direct ignition «HO», «HO o. Umsp mod», «HO o. Umsp 2-stage», «HO o. Umsp 3-stage»	84
Figure 60: Modulating operation X5-03	91
Figure 61: 2-stage operation X5-03	92
Figure 62: 3-stage operation X5-03	92
Figure 63: Shifting multistage operation (OPEN pin 3 / CLOSE pin 2)	93
Figure 64: External load controller via analog input X64 pin 1 / X64 pin 2	96
Figure 65: Definition of curves	101
Figure 66: Restriction of modulation range	104
Figure 67: Adjustment of output	107
Figure 68: Fuel actuator (X54)	110

Figure 69: Air actuator (X53).....	110
Figure 70: Angle definitions with SQM33... ..	113
Figure 71: Direction of rotation (example SQM3...)	114
Figure 72: Function principle of VSD	119
<i>Figure 73: Connection of VSD to the LMV37.4.....</i>	<i>120</i>
Figure 74: Sensor disk	122
Figure 75: Speed sensor.....	123
Figure 76: VSD module X74	131
Figure 77: PWM fan X74.....	131
Figure 78: PWM fan X64.....	131
Figure 79: Fuel meter input X75	134
Figure 80: Inputs and outputs	136
Figure 81: Connection via interface COM 92 to superposed systems	137
Figure 82: Communication with display / BCI (RJ11 jack) (X56)	140
Figure 83: Display input / BCI (RJ11 jack) X56.....	140
Figure 84: Description of unit/display and buttons	144
Figure 85: Meaning of display.....	145
Figure 86: Assignment of levels.....	158
Fig. 87: Info level.....	159
Figure 88: Service level	163
Figure 89: Structure of parameter levels.....	171
Figure 90: Setting the curvepoints	190
Figure 91: Changing several curvepoints	196