

FLMTR Series

KT-BMK-PLC... Gas Flow Meter Kits for Flow Totalization

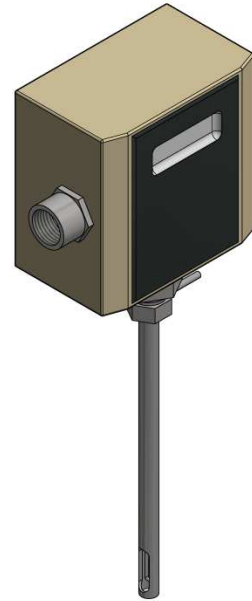

Product Information

The Gas Flow Meter Kit for Flow Totalization measures and displays the instantaneous flow of natural gas or propane and relays the information to a PLC.

Recommended Installation Tools

1. NPT thread sealant
 2. Tape measure
 3. 11/16" and 7/8" open end wrenches
-

Components Supplied

Figure 1 shows all of the components that are supplied with a KT-BMK-PLC... totalization kit.



Figure 1: Components Included in a KT-BMK-PLC... Totalization Kit

1. Flow meter with 1/2" NPT conduit connection
2. 115 / 230 VAC to 15 VDC power supply
3. Stainless steel tubing adapter for 3/8" tube, 1/2" NPT connection, with stainless steel ferrule installed

Installation Procedure

- The flow meter may be mounted in horizontal or vertical piping. The flow meter must be mounted at least 10 pipe diameters downstream of disturbances (elbows, reducers, etc.) and at least 5 pipe diameters upstream of disturbances. Longer distances of straight pipe may be necessary depending on the piping arrangement. See Figure 2 below for the necessary distance of straight pipe upstream and downstream of the meter. If the meter is not mounted per the requirements below, unstable flow readings may result.

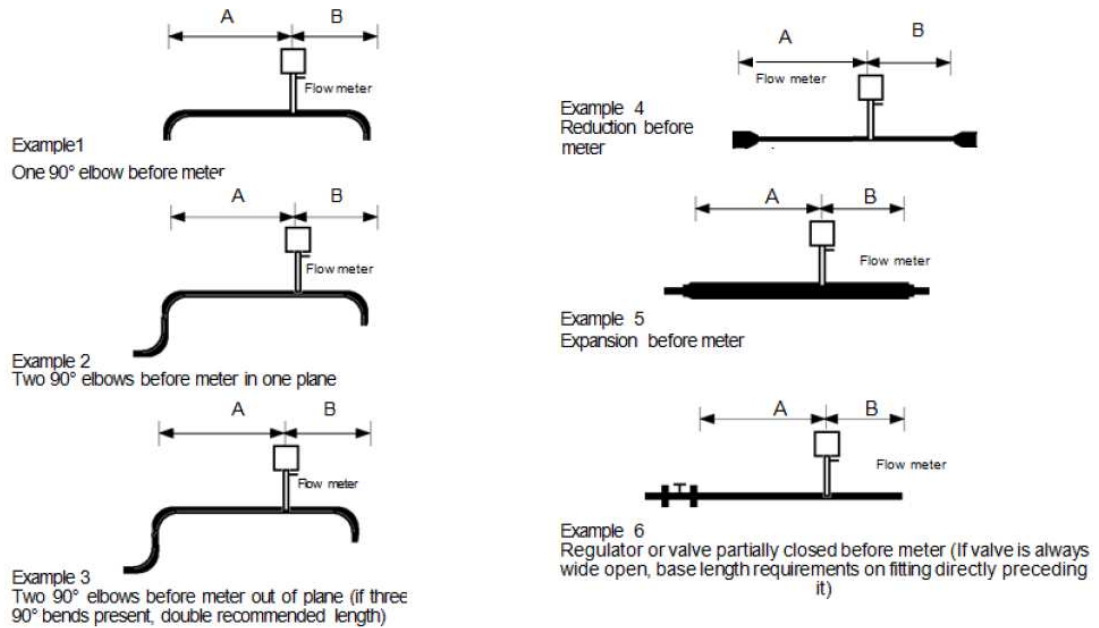

Figure 2-1. Recommended Pipe Length Requirements for Installation

Example	A – Upstream Requirements	B – Downstream ⁽²⁾ Requirements
1	15 D	5 D
2	20 D	5 D
3	40 D	10 D
4	15 D	5 D
5	30 D	10 D
6	40 D	5 D

(1) Number of diameters (D) of straight pipe required between upstream disturbance and the flow meter.
(2) Number of diameters (D) of straight pipe required downstream of the flow meter.

Figure 2: Necessary Amount of Straight Pipe for Mounting Flow Meter

Installation Procedure (continued)

2. Once a suitable location has been found, identify the pipe size. Then, use Table 2 in Appendix A to verify that the gas velocity through the pipe in this location is less than 166 ft/sec when the burner is at high fire.
3. Verify that the static pressure in the pipe is less than 50 PSIG and the gas temperature (when flowing) is between 20°F and 120°F.
4. Verify that the gas piping into which the meter is going to be inserted is depressurized. If not, close the upstream gas valve and bleed off any residual trapped gas.
5. If a ½" NPT or larger half coupling is not available in a suitable location, one will need to be welded onto the pipe with a ½" or larger hole drilled through the pipe wall in the center of the coupling. After this is completed, the assembly should look like Figure 3.

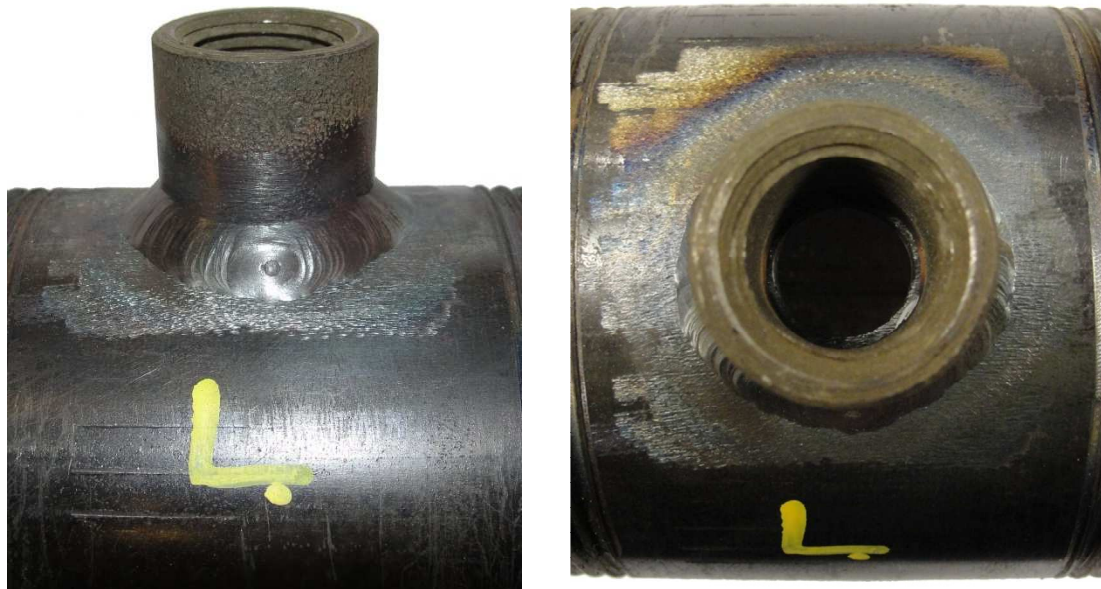

Figure 3: ½" NPT Half Coupling Welded to Pipe with ½" Hole Drilled Through Center

Installation Procedure (continued)

6. Screw the tubing adapter into the ½" NPT half coupling using the 7/8" open end wrench. Thread sealant should be used to seal the NPT threads of the tubing adapter.
7. Insert the meter sensing tube into the tubing adapter. Using Table 1 and Figure 4, center the meter's sensing element in the pipe by setting distance "X" (distance from the outer diameter of the pipe to the bottom of the pointer). This can be done carefully with a tape measure. Ensure that the pointer on the flow meter is pointing in the direction of flow.

Pipe Size	Distance "X"
1"	5.34"
1-1/4"	5.17"
1-1/2"	5.05"
2"	4.81"
2-1/2"	4.56"
3"	4.25"
4"	3.75"
5"	3.22"
6"	2.69"

Table 1: Meter Insertion Distance

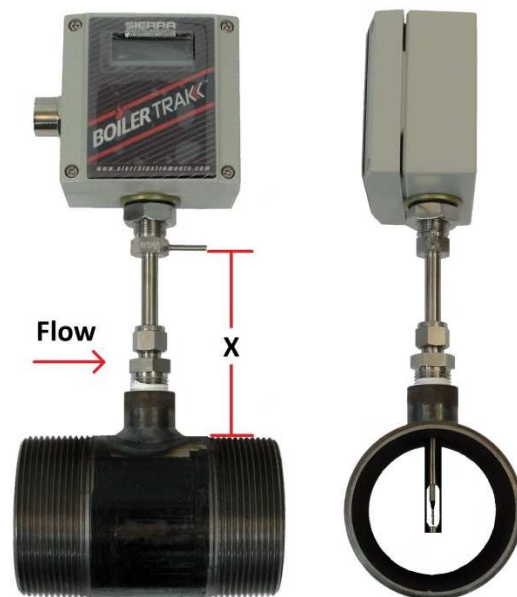

Figure 4: Meter Inserted into Pipe

8. After the meter is inserted to the correct depth with the pointer in the direction of flow, tighten the tube adapter nut with the 11/16" open end wrench.

Note: Make sure that the meter is at the correct depth in the pipe before tightening the tube adapter nut. Tightening this nut will cause the stainless steel ferrule to bite (swage) into the tube of the meter. The location of the ferrule is permanent after it is swaged onto the tube!

Installation Procedure (continued)

9. Wire the flow meter, 15 VDC power supply, and PLC as shown in Figure 5.

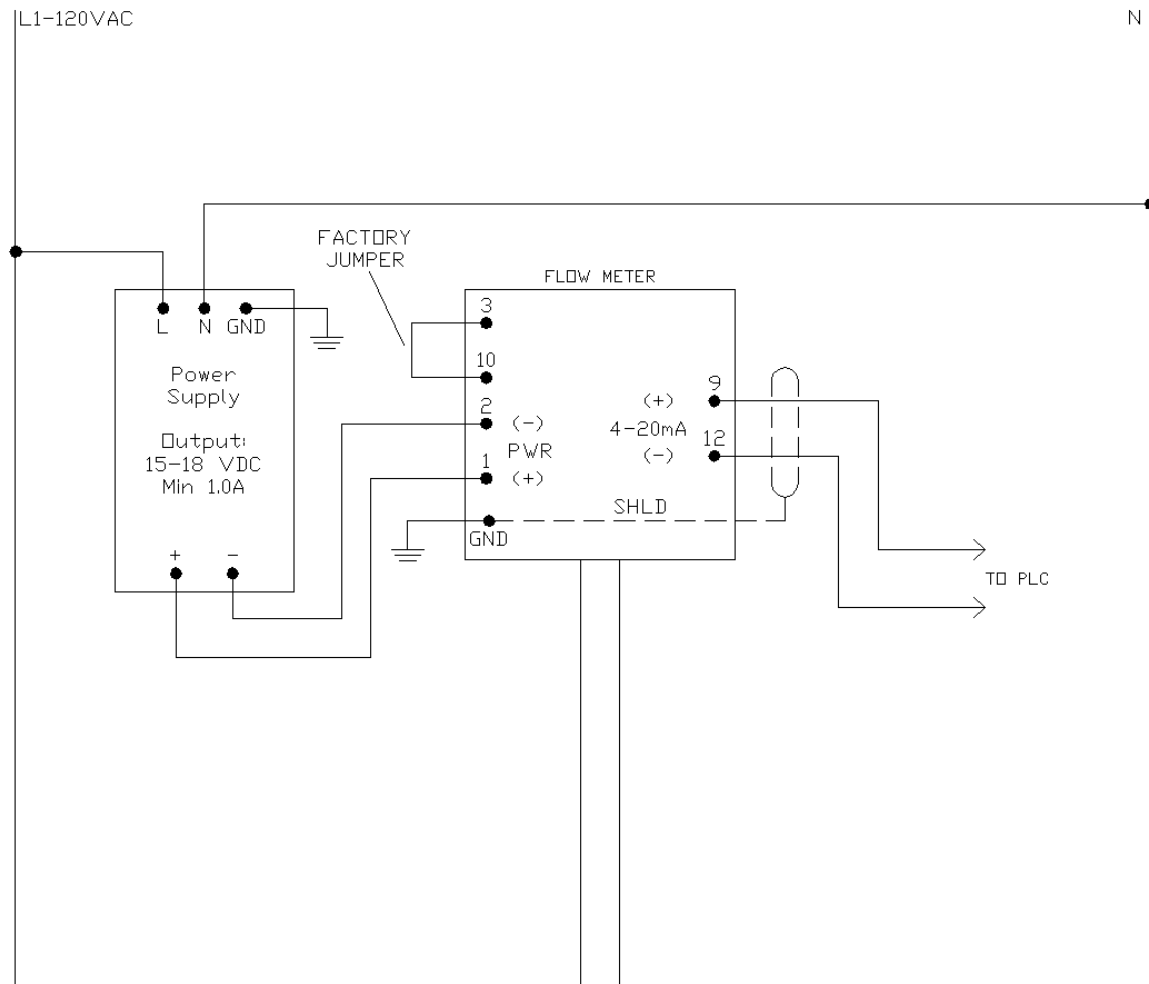

Figure 5: Flow Meter Kit Wiring

10. Scale the PLC accordingly. The flow meter will send 4 mA when there is 0 SCFH and 20 mA when there is maximum flow (see Table 2 in Appendix A).
11. With the main fuel valves closed, the local display on the gas meter should read 0 SCFH. If this is not the case, the “Current Zero Adjustment” of the gas flow meter may need to be changed slightly. To change the “Current Zero Adjustment” of the gas flow meter, refer to Section 3 in the gas flow meter instruction manual. Note that this should only be changed very slightly, if at all.

Appendix A

Table 2: Schedule 40 Pipe Velocities and Flows

SCC Part Number	Pipe Size	Maximum Flow (SCFH)	Maximum Capacity (BHP)
KT-BMK-PLC-100	1"	3601	91
KT- BMK-PLC-125	1-1/4"	6232	158
KT- BMK-PLC-150	1-1/2"	8483	215
KT- BMK-PLC-200	2"	13982	355
KT- BMK-PLC-250	2-1/2"	19949	507
KT- BMK-PLC-300	3"	30803	782
KT- BMK-PLC-400	4"	53042	1347
KT- BMK-PLC-500	5"	83358	2117
KT- BMK-PLC-600	6"	120376	3057
KT-BMK-PLC-100-PRO	1"	3601	229
KT- BMK-PLC-125-PRO	1-1/4"	6232	396
KT- BMK-PLC-150-PRO	1-1/2"	8483	538
KT- BMK-PLC-200-PRO	2"	13982	887
KT- BMK-PLC-250-PRO	2-1/2"	19949	1266
KT- BMK-PLC-300-PRO	3"	30803	1955
KT- BMK-PLC-400-PRO	4"	53042	3390
KT- BMK-PLC-500-PRO	5"	83358	5291
KT- BMK-PLC-600-PRO	6"	120376	7641

Notes:

1. Boiler Horsepower numbers assume a natural gas heating value of 1000 BTU / SCF, a propane heating value of 2500 BTU / SCF, and a boiler efficiency of 85%.

Information in this publication is based on current specifications. The company reserves the right to make changes in specifications and models as design improvements are introduced. Product or company names mentioned herein may be the trademarks of their respective owners. © 2019 SCC Inc.