

BR-N4-SQM4...

Product Description

BR-N4-SQM4... NEMA 4 kits provide the shaft seal and cable gland necessary to achieve a NEMA 4 seal on any SQM45... or SQM48... actuator.

Components Supplied

Figure 1 shows the components supplied with a BR-N4-SQM4... NEMA 4 kit:

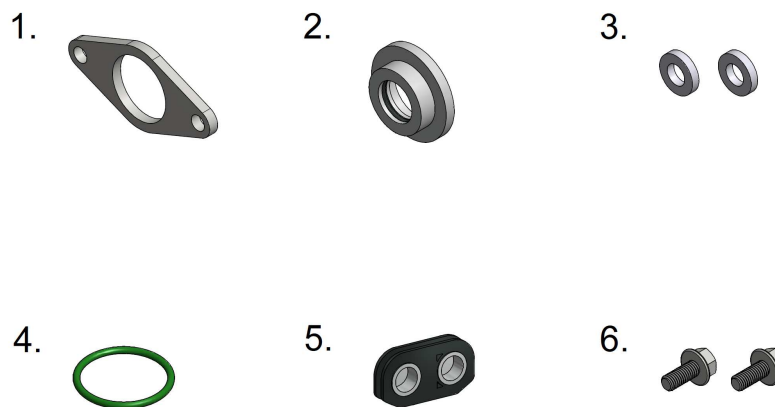

Figure 1: Components Supplied with a BR-N4-SQM4... NEMA 4 Kit

1. Seal retainer
2. Shaft seal
3. (2) M5 spacers
4. Shaft seal O-ring
5. Replacement cable gland
6. (2) M5 x 12mm thread-forming screws

Recommended Installation Tools

The following tools are recommended for installing a BR-N4-SQM4... NEMA 4 kit:

- 8mm nut driver or 8mm socket with ratchet and extension
- Flathead screwdriver
- Wire-cutting pliers (SQM48... only)
- Hammer (SQM48... only)
- File (SQM48... only)

Installation Procedure

1. Loosen the three screws in the cover of the SQM4... actuator and remove the cover. After power is removed from the actuator, disconnect the actuator wiring. Disconnect any conduit connections and pull the wires out of the actuator's cable gland. Disconnect the ground connector from the metal grounding clip on the cable gland. Remove the cable gland and discard it. Place the provided cable gland where the old gland used to sit. Reconnect the ground connector and any conduit and wiring that was disconnected. Replace the actuator cover and tighten the three screws sufficiently to compress the O-ring around the center of the cable gland. **It is highly recommended to use a flathead screwdriver to tighten the three screws in the cover in order to provide sufficient compression of the cable gland O-ring.**
2. On SQM48... actuators only, remove the key from the actuator shaft. This is easily done by gripping the sides of the key with a pair of wire-cutting pliers and gently prying the key out of the shaft as shown in Figure 2.



Figure 2: Removing the Key from an SQM48... Actuator

Installation Procedure (continued)

3. Place the shaft seal O-ring into the annular groove on the back of the shaft seal. Then, slide the shaft seal over the actuator shaft as shown in Figure 3. Make sure that the shaft seal O-ring does not fall out of the annular groove when sliding the shaft seal over the actuator shaft.

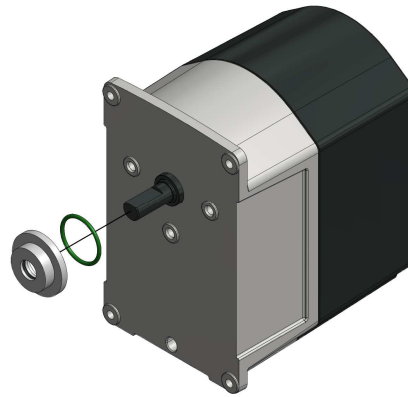

Figure 3: Shaft Seal Assembly

4. Place an M5 x 12mm thread-forming screw through each hole in the seal retainer. Slide an M5 spacer over the end of each M5 x 12mm thread-forming screw. Slide the current assembly over the actuator shaft so that each M5 x 12mm thread-forming screw lines up with one of the three holes in the bottom of the actuator as shown in Figure 4. The seal retainer should slide over the shoulder on the shaft seal. Using the 8mm nut driver (or socket), tighten the two M5 x 12mm thread-forming screws until the M5 spacers are captured between the seal retainer and the bottom of the actuator. **Do not overtighten the M5 x 12mm thread-forming screws.**

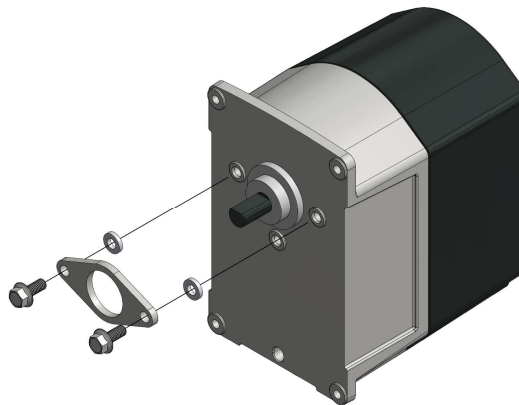

Figure 4: Seal Retainer Installation

Installation Procedure (continued)

5. After the M5 x 12mm thread-forming screws are tightened, the seal retainer will be slightly bent which is intentional in order to compress the shaft seal O-ring. On SQM48... actuators only, replace the actuator key that was removed in step 2 by tapping it gently with the end of a hammer handle. If any burrs were made on the key when removing it from the actuator, remove them with a file before placing the key back into the actuator shaft. At this point, the NEMA 4 kit installation is complete.

Information in this publication is based on current specifications. The company reserves the right to make changes in specifications and models as design improvements are introduced. Product or company names mentioned herein may be the trademarks of their respective owners. © 2009 SCC Inc.